

GASPARDO

MASCHIO GASPARDO S.p.A.

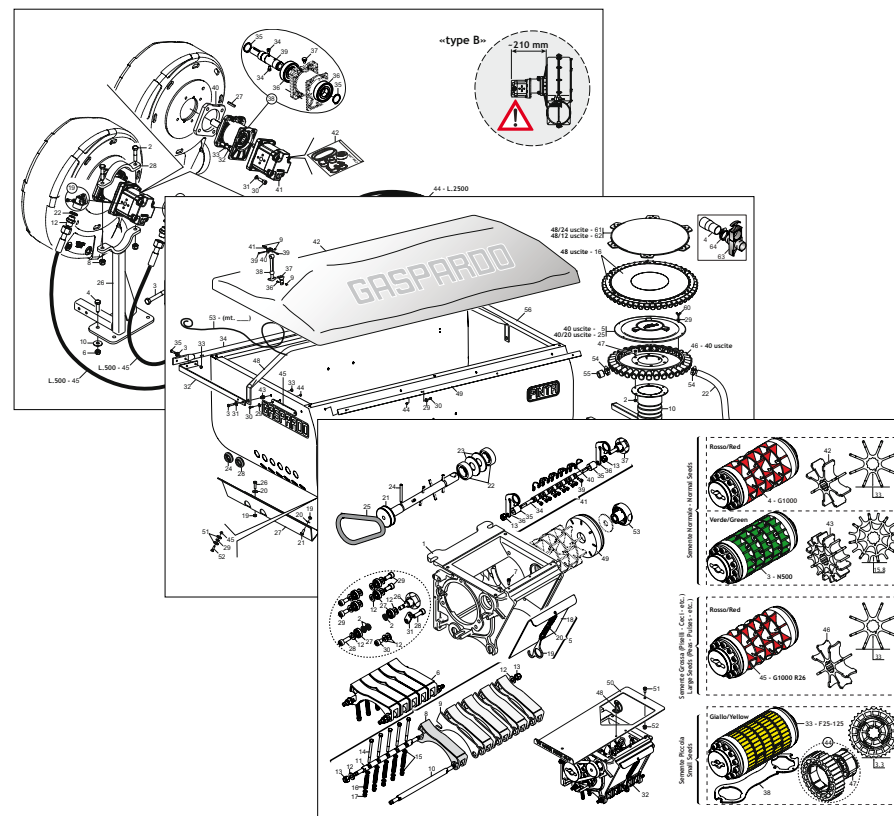

PINTA SC

Cod: G19531740 2018-02

- *) Valido per Paesi UE
- *) Valid for EU member countries
- *) Gilt für EU-Mitgliedsländer
- *) Valable dans le Pays UE
- *) Válido para Países UE
- *) Valabil pentru țările UE

- IT** PARTI DI RICAMBIO
- EN** SPARE PARTS
- DE** ERSATZTEILE
- FR** PIÈCES DÉTACHÉES
- ES** PIEZAS DE REPUESTO

PARTI DI RICAMBIO

Le ordinazioni delle parti di ricambio vanno fatte presso i nostri concessionari di zona e devono essere sempre corredate dalle seguenti indicazioni:

- **Tipo, modello e numero di matricola dell'attrezzatura.** Tali dati sono stampigliati nell'apposita targhetta di cui è dotata ogni attrezzatura.

- **Numero di codice della parte richiesta** rilevabile dal catalogo ricambi.

- **Descrizione del particolare e quantità richiesta.**

- **Numero della tavola.**

- **Mezzo di trasporto.** Nel caso questa voce non sia specificata, la Ditta Costruttrice, pur dedicando a questo servizio una particolare cura, non risponde di eventuali ritardi di spedizione dovuti a cause di forza maggiore.

Le spese di trasporto si intendono sempre a carico del destinatario. La merce viaggia a rischio e pericolo del committente anche se venduta franco destino.

NOTA: Il termine **(Dx) Destro** o **(Sx) Sinistro** della macchina o di parti di essa, è inteso guardando la macchina dalla parte posteriore. Le eccezioni saranno indicate.

SPARE PARTS

Orders must be transmitted through our area dealers and should always include the following indications:

- **Type, model and serial number of the machine.** These data are punched on the data plate with which every implement is equipped.

- **Code number of the required spare part.** This will be found in the spare parts catalogue.

- **Description of the part and required quantity.**

- **Table number.**

- **Means of dispatch.** If this item is not indicated, the Manufacturer, while dedicating particular care to this service, shall not be held responsible for delays in delivery caused by cases of force majeure.

Transport expenses shall always be at the consignee's charge. The goods travel at the purchaser's risk and peril even when sold ex destination.

NOTE: The symbols **(Dx) right** and **(Sx) left**, concerning the machine or single parts of it, are referred, as in the figure, to a rear view of them. Exceptions will be indicated.

ERSATZTEILE

Die Bestellungen müssen bei unseren Gebietshändlern aufgegeben werden. Bei der Bestellung sind stets die folgenden Angaben zu machen:

- **Typ, Modell und Serien-Nummer des Geräts.** Diese Daten stehen auf dem Typenschild, mit dem jedes Gerät versehen ist.

- **Artikel Nr. der erforderlichen Ersatzteile.** Diese stehen im Ersatzteil-Katalog.

- **Beschreibung des Ersatzteils und die erforderliche Stückzahl.**

- **Tafelnummer.**

- **Versandmittel.** Wenn dieser Punkt nicht spezifiziert wird, haftet die Herstellerfirma nicht für etwaigen Lieferverzug aufgrund höherer Gewalt, auch wenn er diesen Service besonders aufmerksam abwickelt. Die Frachtkosten gehen dagegen immer zu Lasten des Empfängers. Die Ware reist auf Gefahr und Risiko des Auftraggebers, auch wenn frei Haus Verkauft vereinbart worden ist.

N.B.: Die Merkzeichen **(Dx) rechts** und **(Sx) links** betreffen eine rückwärtige Aussicht der Maschine oder Teile von ihr (siehe Bild). Ausnahmen werden gezeit.

PIECES DÉTACHÉES

Les ordres doivent être effectués auprès de nos concessionnaires de zone en précisant les indications suivantes:

- **Type, modèle et numéro de série de la machine.** Ces données sont gravées sur la plaque d'identification de chaque outil.

- **Numéro de code de la pièce détachée** indiqué sur le catalogue des pièces détachées.

- **Description de la pièce et quantité requise.**

- **Numéro de plan.**

- **Moyen d'expédition.** Si cette rubrique n'est pas indiquée, le Constructeur, bien que soucieux de ce service, ne répond pas des retards d'expédition pour des causes de force majeure.

Les frais de transport sont toujours à la charge du destinataire. La marchandise voyage aux risques et périls de l'acheteur même si vendue franco de port.

N.B.: Les références **(Dx) droit** et **(Sx) gauche** de la machine ou des parties de la même, est entendue, comme de la figure, en regardant la machine de derriere dans le sens de marche.

RESPUESTOS

Los pedidos han de efectuarse en nuestros concesionarios de zona y deben incluir siempre las siguientes indicaciones:

- **Tipo, modelo y número de matricula del equipo.** Dichos datos están impresos en la relativa placa presente en el equipo.

- **Número de código de la parte requerida** presente en el catálogo respuestas.

- **Descripción de la pieza y cantidad requerida.**

- **Numero de ilustración.**

- **Medio de transporte.** En caso que este ítem no esté especificado, el Fabricante, aún prestando la debidas consideraciones para este aspecto, no responde por eventuales retardos de env'o debidos a causas de fuerza mayor.

Los gastos de transporte se consideran siempre a cargo del destinatario. La mercadería viaja bajo riesgo y peligro del comprador, incluso cuando se vende franco destino.

N.B.: La referencia **(Dx) derecha** o **(Sx) izquierda** de la máquina o de sus componentes, se entiende, como en la figura, mirando la máquina por la parte trasera. Se indicarán las excepciones.

Nr. Tav.	Descrizione	Description	Pag.
TAV. 010	Telaio.....	Frame.....	4
TAV. 020	Impianto oleodinamico telaio.....	Hydraulic frame system.....	6
TAV. 030	Ruote.....	Wheels.....	8
TAV. 070	Tramoggia.....	Hopper.....	10
TAV. 050	Dosatore SEME.....	SEED Doser.....	12
TAV. 080	Dosatore CONCIME.....	FERTILIZER Doser.....	14
TAV. 090	Azionamento elettrico dosatore SEME.....	Electric SEED dosing.....	16
TAV. 100	Azionamento elettrico dosatore CONCIME.....	Electric FERTILIZER dosing.....	18
TAV. 120	Gestione elettrica «GENIUS MASTER».....	Electrical system - «GENIUS MASTER».....	20
TAV. 320	Scatola comando elettrico «GENIUS MASTER».....	Electrical control box - «GENIUS MASTER».....	22
TAV. 141	Parzializzatore semina.....	Seeding partializer.....	24
TAV. 150	Soffiante.....	Blower.....	26
TAV. 160	Azionamento meccanico soffiante.....	Fan mechanical drive.....	28
TAV. 170	Soffiante ad azionamento oleodinamico dipendente (type A).....	Fan drive by hydraulic dependent system (type A).....	30
TAV. 171	Soffiante ad azionamento oleodinamico dipendente (type B).....	Fan drive by hydraulic dependent system (type B).....	32
TAV. 180	Soffiante ad azionamento oleodinamico indipendente (type A).....	Fan drive by hydraulic independent system (type A).....	34
TAV. 181	Soffiante ad azionamento oleodinamico indipendente (type B).....	Fan drive by hydraulic independent system (type B).....	38
TAV. 190	Telaio barra assolcatori.....	Frame to coulter bar.....	42
TAV. 200	Assolcatori a stivaletto.....	Shoe coulter.....	44
TAV. 210	Assolcatori a disco semplice.....	Single disc coulter.....	46
TAV. 220	Assolcatori a disco semplice «DV».....	Single disc coulter «DV».....	48
TAV. 230	Assolcatori a disco «COREX».....	«COREX» disc coulter.....	50
TAV. 240	Pedana di ispezione e scaletta.....	Inspection footboard with ladder.....	52
TAV. 250	Segnafile.....	Row marker.....	54
TAV. 260	Erpice copriseme.....	Seed covering harrow.....	56

Versione TRAINATA / TRAILED Version

TAV. 270	Kit traino - Timone.....	Pull hitch kit - Drawbar.....	58
TAV. 280	Kit traino - Ruota Destra.....	Pull hitch kit - Right Wheel.....	60
TAV. 290	Kit traino - Impianto oleodinamico.....	Pull hitch kit - Hydraulic system.....	62
TAV. 300	Cardano.....	Cardan shaft.....	64
TAV. 330	Kit luci e tabelle di ingombro stradale.....	Lighting kit and warning boards.....	66
TAV. 310	Kit luci e tabelle di ingombro stradale.....	Lighting kit and warning boards.....	68

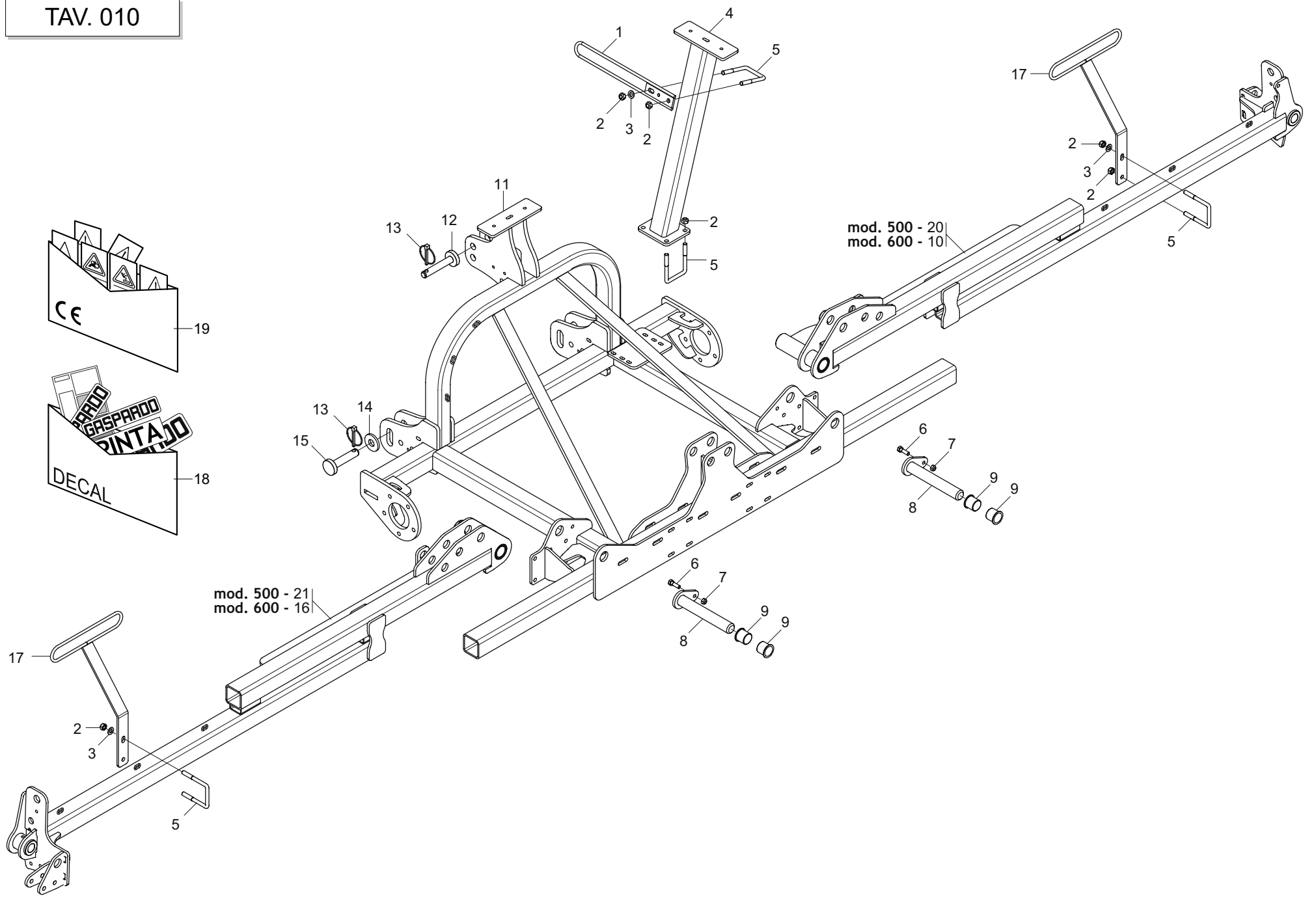

TELAIO FRAME

TAV. 010

Pos.	Cod.	Descrizione	Description	Description	Benennung	Descripcion
1	G16075660R	GUIDA TUBO SU TELAIO	GUIDE TUBE FRAME			
2	F01220255R	DADO M14X2 D980 8ZN	NUT M14X2 D980 8ZN	ECROU M14X2 D980 8 ZN	MUTTER M14X2 D980 8 ZN	TUERCA M14X2 D980 8 ZN
3	F01410088R	ROS.M14 15X 28X2,5 U6592 ZN	WAS.M14 15X 28X2,5 U6592 ZB	RON.M14 15X 28X2,5 U6592 ZB	SCH.M14 15X 28X2,5 U6592 ZB	ARA.M14 15X 28X2,5 U6592 ZB
4	G16074600R	SUPPORTO LATERALE TRAMOGGIA	SIDE HOPPER SUPPORT			
5	F20110770R	CAV.Q.B=80 M=14X2 L=119	U BOLT Q.B=80 M=14X2 L=119	BRIDE U M14X2X50 96X119 ZN	ANSCHLANG U M14X2X50 96X119 ZN	EL.DE EMPALME M14X2X50 96X119
6	F01020152R	VITE M12X1,75X40 U5737 8.8ZN	SCR. M12X1,75X40 U5737 8.8ZN	VIS M12X1,75X40 U5737 8.8 ZN	SCHRAUBE M12X1,75X40U57378.8ZN	TORNIL.M12X1,75X40 U5737 8.8ZN
7	F01220048R	DADO M12X1,75 D980 8ZN	NUT M12X1,75 D980 8ZN	ECROU M12X1,75 D980 8 ZN	SCHEIBE M12X1,75 D980 8 ZN	TUERCA M12X1,75 D980 8 ZN
8	G16074970R	SPINA ZN	PIN			
9	F04150035R	CUSCIN.FLANG.GFM-4044-40	BEARING FLANG.GFM-4044-40			
10	G16074490R	BRACCIO PIEGH.DX PINTA 600	RIGHT FOLDING ARM PINTA600			
11	G16074350R	TELAIO PINTA 600	FRAME PINTA 600			
12	F20100133R	PERNO D25 L122 C43 TEST.D60 ZN	PIN D25 L122 C43 ZN	BOULON D25 L122 C43 ZN	BOLZEN D25 L122 C43 ZN	PERNO D25 L122 C43 ZN
13	F02200507R	SPINA A SCATTO D 9 B 83	SNAP PIN D9 B 83 ZN	FICHE A DETENTE D9 B 83 ZN	EINRASTSTIFT D9 B 83 ZN	CLAVIJA DE MUELLE D9 B 83 ZN
14	G20970120R	RONDELLA 70X8X28,5	WASHER 70X8X28-5	RONDELLE 70X8X28-5	UNTERLEGSCHIEBE 70X8X28-5	ARANDELA 70X8X28-5
15	F20100136R	PERNO D28 L109 C43 TEST.D60 Z	BOLT D28 L109 C43 ZN	BOULON D28 L109 C43 ZN	BOLTZEN D28 L109 C43 ZN	PERNO D28 L109 C43 ZN
16	G16074500R	BRACCIO PIEGH.SX PINTA 600	LEFT FOLDING ARM PINTA600			
17	G16075620R	GUIDA TUBI TELAIO LATERALE	GUIDE TUBE FRAME			
18	G89900519R	KIT DECALCOMANIE ALIANTE	STICKER KIT ALIANTE	KIT DECALCOMANIE ALIANTE	KIT ABZIEHB. ALIANTE	SET CALCOMANAS ALIANTE
19	G89900500R	KIT DECALCOMANIE -CE-	DECAL KIT -CE-	KIT DECALCOMANIE -CE-	KIT ABZIEHB. -CE-	SET CALCOMANAS -CE-
20	G16076070R	BRACCIO PIEG.DX PINTA500XL	PINTA500XL RIGHT FOLDABLE ARM			
21	G16076080R	BRACCIO PIEG.SX PINTA500XL	PINTA500XL LEFT FOLDABLE ARM			

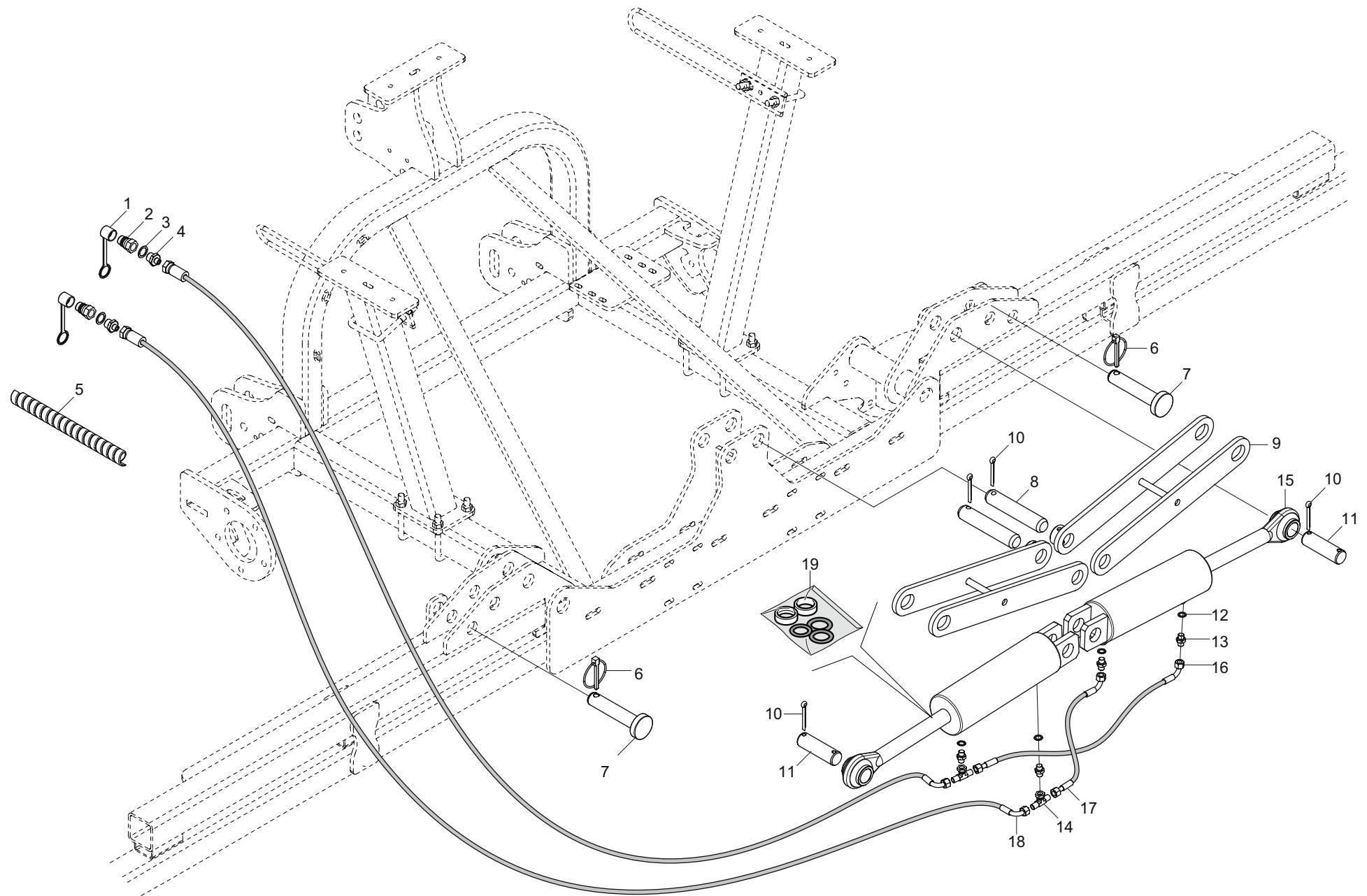

**IMPIANTO OLEODINAMICO TELAIO
HYDRAULIC FRAME SYSTEM**

TAV. 020

Pos.	Cod.	Descrizione	Description	Description	Benennung	Descripcion
1	F05150325R	CAPPUC.F X INN.M RAP.1 2 ROSS	COVER CONNECT F 1 2 RED	COUVERCLE CONNEXION F 1 2 ROSE	DECKEL W 1 2 SCHNELLKUPP. ROT	PAC PROTECCION F 1 2 ROJO
2	F03150935R	INNESTO RAP.MASCH.1 2 A VALV.	QUICK CONNECT MALE CONE 1 2	CONNEXION RAPIDE MALE CONE 1 2	SCHNELLKUPP.GEWINDE KONISC 1 2	ACOPLAMIENT.RAP.MACHO CONO 1 2
3	F03151237R	ROS. 21 X27X1,5 RAME -1 2	COPPER WASHER 21X27X1,5 1 2	RONDELLE CUIVRE 21X27X1,5 1 2	SCHEIBE KUPFER 21X27X1,5 1 2	ARANDELA COBRE 21X27X1,5 1 2
4	F03150211R	NIPPLO MM CIL-CIL 1 2-1 4 ZN	NIPLE MM CIL-CIL 1 4-1 2 ZN	NIPLE MM 1 4-1 2 ZN	NIPLE GG 1 4-1 2 ZN	NIPLE MM 1 4-1 2 ZN
5	F05150484R	SPIRALE PROTETTIVA D.27-32	PROTECTIVE SPIRAL D.27-32	SPIRALE DE PROTECTION D.27-32	SPIRAL SCHUTZ D.27-32	ESPIRAL PROTECIEN D.27-32
6	F02200507R	SPINA A SCATTO D 9 B 83	SNAP PIN D9 B 83 ZN	FICHE A DETENTE D9 B 83 ZN	EINRASTSTIFT D9 B 83 ZN	CLAVIJA DE MUELLE D9 B 83 ZN
7	F20100139R	PERNO D32 L135 C43 TEST.D60 Z	PIN D32 L135 C40 ZN	BOULON D32 L135 C43 ZN	BOLTZEN D32 L135 C43 ZN	PERNO D32 L135 C43 ZN
8	G16113350R	SPINA 35,00X180 2F11 147 NP	PIN 35X180 2H11 147 NP	GOUPILLE 35X180 NP	BOLZENSTIFT 35X180 NP	PASADOR 35X180 NP
9	G17915232R	ASS.DI SICUREZZA	ASSY SAFETY			
10	F02200260R	COPIGLIA 8X 60 U1336 ZN	SPLIT PIN 8 X60 1336 ZN	GOUPILLE 8 X60 1336 ZN	SPLINT 8 X60 1336 ZN	PASADOR 8 X60 1336 ZN
11	R17012460R	SPINA 35X99 ZN	PIN 35X99 ZN	FICHE EL. 35X99 ZN	STIFT 35X99 ZN	CLAVIJA 35X99 ZN
12	F01500012R	RONDELLA IN RAME 1 4	COPPER WASHER 13X19X1,5-1 4	RONDELLE 13X19X1,5-1 4	SCHEIBE 13X19X1,5-1 4	ARANDELA 13X19X1,5-1 4
13	G16011690R	MONT.NIPPLO 1 4 GRANO F.1,0	UPRIGHT 1 4 NIPPLE WITH GRUB	MONTANT NIPPLE 1 4 AVEC GRAIN	STZNDER NIPPEL 1 4 MIT STIFT 8	MONT.NIPLE 1 4 TORNIL.SIN CABE
14	F03151216R	RACCORDO -T- CENTR.M-FG-M 1 4	UNION T M-M-F 1 4 ZN	RACCORD T M-M-F ZN	ANSCHLUSSTSCK TM-M-F 1 4 ZN	UNI N T M-M-F 1 4 ZN
15	G17913720R	CILINDRO TELAIO POSTERIORE	REAR FRAME CYLINDER			
16	G17911270R	TUBO 1 4R2 CF-F L. 700	PIPE 1 4R2 CF-F L. 700	TUBE 1 4R2 CF-F L. 700	ROHR 1 4R2 CF-F L. 700	TUBO 1 4R2 CF-F L. 700
17	G16011670R	TUBO 1 4 R2 C-F 1 4 L.500	PIPE 1 4 R2 C-F 1 4 L.500	TUBE 1 4 R2 C-F 1 4 L.500	ROHR 1 4 R2 C-F 1 4 L.500	TUBO 1 4 R2 C-F 1 4 L.500
18	G15210554R	TUBO 1 4R2 F1 4-CF1 4 2850	TUBE 1 4R2 F1 4-CF1 4 2850			
19	F03100230R	KIT GUARNIZ.CILINDRO 17913720	CYL.GASKET KIT 17913720			

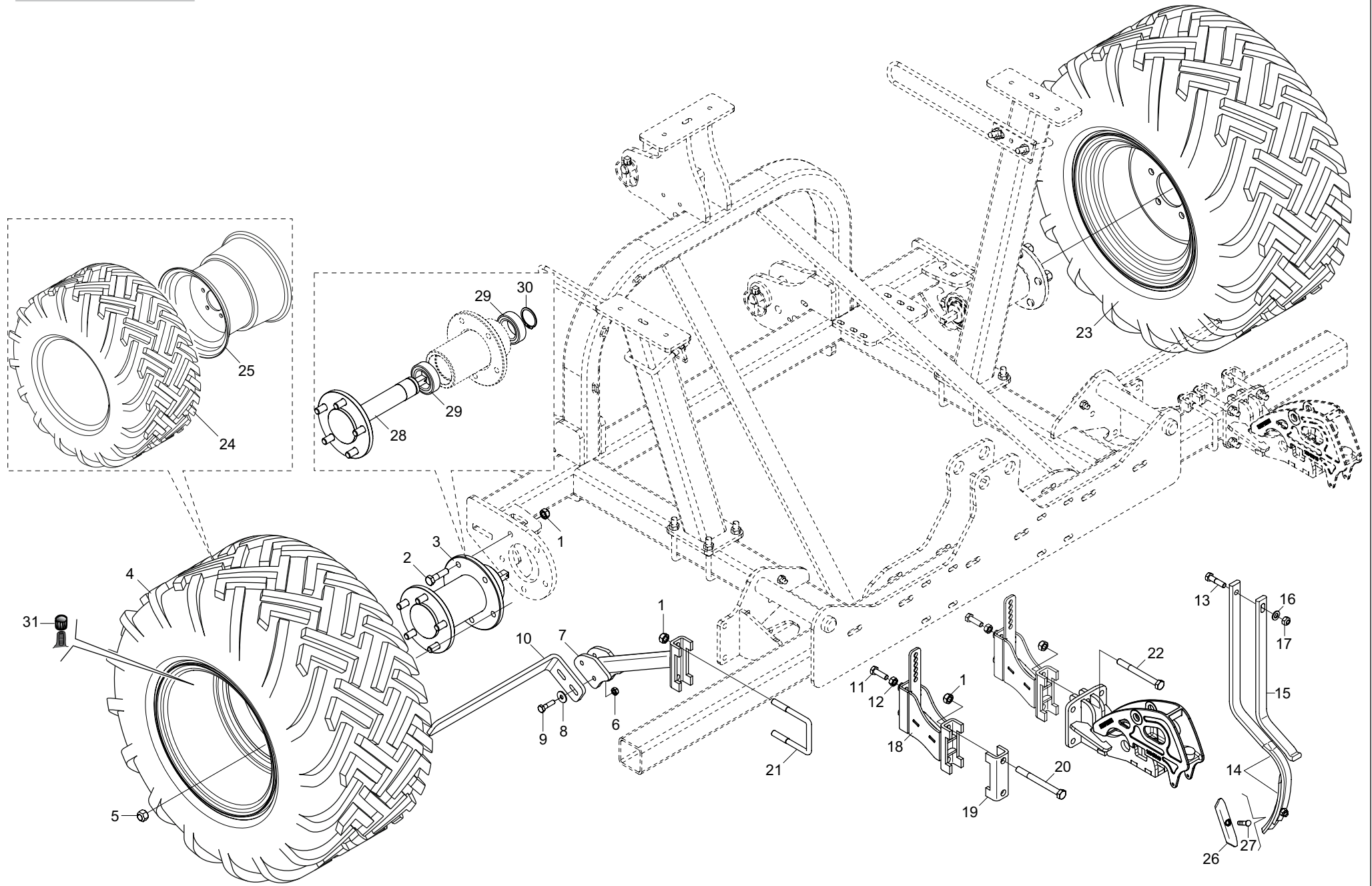

RUOTE WHEELS

TAV. 030

Pos.	Cod.	Descrizione	Description	Description	Benennung	Descripcion
1	F01220255R	DADO M14X2 D980 8ZN	NUT M14X2 D980 8ZN	ECROU M14X2 D980 8 ZN	MUTTER M14X2 D980 8 ZN	TUERCA M14X2 D980 8 ZN
2	F01020201R	VITE M14X2X55 U5737 8.8ZN	SCR. M14X2X55 U5737 8.8ZN	VIS M 14X55	SCHRAUBE M 14X55	TORNILLO M 14X55
3	G16075670R	MOZZO RUOTA COMPL.	WHEEL HUB			
4	F06120282R	RUOTA 31X15.5-15 SX	WHEEL 31X15.5-15 SX			
5	F01250046R	DADO COLON. 16X1,5 ZN	NUT STUD M16X 1.5 ZN	ECROU M16X1,5 COLONNETTE ZN	SCHRAUBBOLZENMUTTER M16X1,5 ZN	TUERCA M16X1,5 COLUMNA ZN
6	F01220033R	DADO M10X1,5 D980 8ZN	NUT M10X1,5 D980 8ZN	ECROU M10X1,5 D980 8ZN	MUTTER M10X1,5 D980 8ZN	TUERCA M10X1,5 D980 8ZN
7	G16075890R	SUPPORTO RASCHIATERRA	SOIL SCRAPER SUPPORT			
8	F01420060R	ROS.M10 10,5X 30X2,5 U6593 ZG	GALV.WASHER 10,5X30X2,5 U6593	RONDELLE 10,5X30	SCHEIBE 10,5X30	ARANDELA 10,5X30
9	F01020110R	VITE M10X1,5X40 U5737 8.8ZN	SCR. M10X1,5X40 U5737 8.8ZN	VIS M 10X40	SCHRAUBE M 10X40	TORNILLO M 10X40
10	G17932320R	LAMA RASCHIATERRA	SOILSCRAPER BLADE			
11	F01020528R	VITE M12X1,75X40 U5739 10.9ZN	BOLT M12X1,75X40 U5739 10.9ZN	VIS M12X1,75X40 U5739 10.9 ZN	SCHR.M12X1,75X40 U5739 10.9 ZN	TORN.M12X1,75X40 U5739 10.9 ZN
12	F01200293R	DADO M12X1,75 U5588 CL8 ZN	NUT M12X1,75 U5588 6S ZN	ECROU M12X1,75 U5588 6S ZN	MUTTER M12X1,75 U5588 6S ZN	TUERCA M12X1,75 U5588 6S ZN
13	F01020156R	VITE M12X1,75X50 U5737 8.8ZN	SCR. M12X1,75X50 U5737 8.8ZN	VIS M12X1,75X50 U5737 8.8 ZN	SCHR. M12X1,75X50 U5737 8.8 ZN	TORN. M12X1,75X50 U5737 8.8 ZN
14	G67002019R	ROMPITRACCIA	TRACEBREAKER	BRIS. DE TRACES	SPURMESSER	ROMPEHUELLA
15	G67002020R	RINFORZO ROMPITRACCIA	ROWBRAKER REINFORC.	RENFORT EFFACEUR DE TRACES	VERST-RKUNG SPURLOCKERERZINKEN	REFUERZO ROMPETRAZAS
16	F01410076R	ROS.M12 13X 24X2,5 U6592 ZN	WASHER 12 13X 24X2,5 U6592 ZN	RONDEL. M12 13X24X2,5 U6592 ZN	SCHEIBE M12 13X24X2,5 U6592 ZN	ARANDELA M12 13 X24X2,5 ZN
17	F01220048R	DADO M12X1,75 D980 8ZN	NUT M12X1,75 D980 8ZN	ECROU M12X1,75 D980 8 ZN	SCHEIBE M12X1,75 D980 8 ZN	TUERCA M12X1,75 D980 8 ZN
18	G16075860R	SUPPORTO ROMPITRACCIA	ROWBREAKER SUPPORT			
19	G36200241R	SCONTRO U 80	FLANGE U 80	BRIDE U 80	ANSCHLAG U 80	ELEMENTO DE EMPALME U 80
20	F01020223R	VITE M14X2X150 U5737 8.8BR	SCR. M14X2X150 U5737 8.8BR	VIS 14X150 5737 8.G	SCHRAUBE 14X150 5737 8.G	TORNILLO 14X150 5737 8.G
21	F20110770R	CAV.Q.B=80 M=14X2 L=119	U BOLT Q.B=80 M=14X2 L=119	BRIDE U M14X2X50 96X119 ZN	ANSCHLANG U M14X2X50 96X119 ZN	EL.DE EMPALME M14X2X50 96X119
22	F01020221R	VITE M14X2X140 U5737 8.8BR	SCR. M14X2X140 U5737 8.8BR	VIS M 14 X140 5737 8.G	SCHRAUBE M 14 X140 5737 8.G	TORNILLO M 14 X140 5737 8.G
23	F06120283R	RUOTA 31X15.5-15 DX	WHEEL 31X15.5-15 RIGHT			
24	F06120432R	COPERTURA 31X15.5-15 TR315 8PR	TYRE 31X15.5-15 TR315 8PR			
25	F06120433R	CERCHIO 13X15.5 5F OFF-55 9001	WHEEL RIM 13X15.5 5H OFF-55			
26	F20120013R	VOMERE REVERSIBILE 36X6X210	REVERSIBLE PLOWSHARE 36X6X210	SOC 36X6X210		PUNTAL REVERSIBLE 36X6X210
27	G67002011R	BULLONE TESTE OVALE M10X35	OVAL HEAD BOLT M10X35	BOULON TETE AVALE M10X35	SCHRAUBE OVAL KOPF. M10X35	PERNO CABEZA OVALADO M10X35
28	G17931791R	MONT.ASSE RUOTA	WHEEL AXLE ASS.BLY			
29	F04010347R	CUSC.D50 D80 B23 63010 2RS1	BEARING D50 D80 B23 63010 2RS1	PALIER D50 D80 B23 63010 2RS1	LAGER D50 D80 B23 63010 2RS1	COJINET.D50 D80 B23 63010 2RS1
30	F02050203R	ANELLO E. DE 50X 2 U7435 C70	SEEGER RING D50X2 U7435 C70	ANEL SEEGER D50X2 U7435 C70	SEEGER RING D50X2 U7435 C70	ANILLO SEEGER D50X2 U7435 C70
31	F05050025R	CAPPELOTTO PROTEZ. X VALV.PVC	PROTECTION CAP PVC X VALVA	CAPUCHON PROTECION PVC X VALVA	SCHUTZKAPPE PVC X VENTIL	TAPA PROTECION PVC X VALVA

TAV. 070

mod. PINTA SC

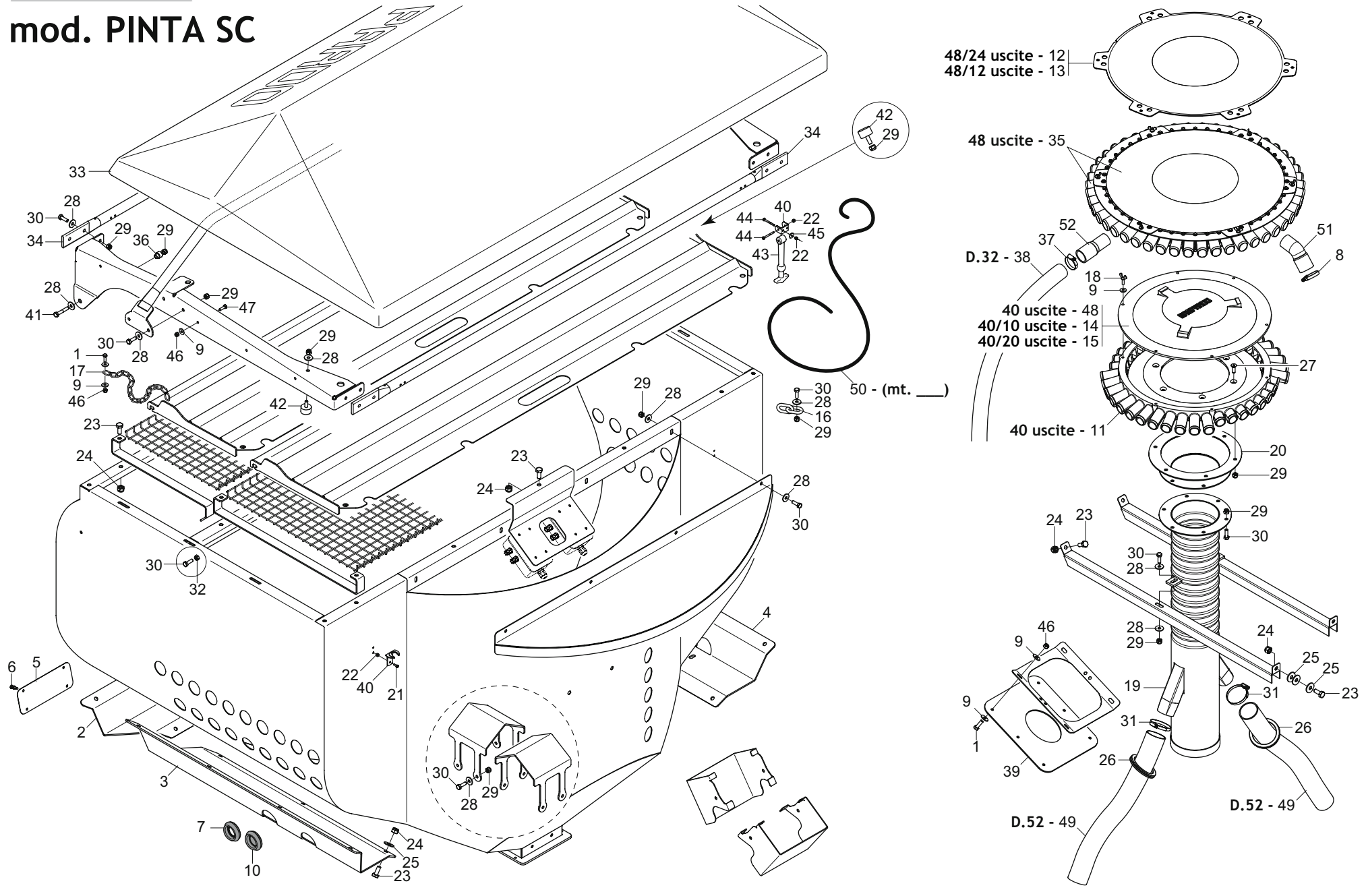

TRAMOGGIA HOPPER

TAV. 070

Pos.	Cod.	Descrizione	Description	Description	Benennung	Description
1	F01020420R	VITE M6X1X20 U5739 A2IX	SCR. M6X1X20 U5739 A2IX	VIS M6 X1 X 20 U5739 8.8 IX	SCHRAUBE M6X1X20 U5739 A2 IX	TORNIL. M6 X1 X 20 U5739 8.8
2	G16023790R	SUPP.ANTERIORE TRAMOGGIA	FRONTAL SUPPORT HOPPER			
3	G16023800R	SUPP.SINISTRO TRAMOGGIA	L. SUPPORT HOPPER			
4	G16023810R	SUPP.DESTRO TRAMOGGIA	R. SUPPORT HOPPER			
5	G19701890R	TARGA GASPARDO IN BASSORILIEVO	GASPARDO PLAQUE			
6	F02250033R	RIVETTO PLAST. P 1506 PER C	PLASTIC RIVET P 1506 PER C	RIVET PLAST. P1506 PER C	REISSNIETE P1506 PER C	REMACHE DESGAR. P1506 PER C
7	G19005150R	GUARNIZIONE FORO D.45 CHIUSO	CLOSED HOLE D.45 GASKET	JOINT TROU D.45 FERM	DICHTUNG FFNUNG D.45 GESCHLO	JUNTA AGUJERO D.45 CERRADO
8	F02300020R	FASCETTA STRING. 32 50 H.9	HOSE CLAMP 32 50 H.9			
9	F01420038R	ROS.M6 6,4X18X1,5 U6593 IX	WASHER M6 6,4X18X1,5 U6593 IX	RONDELLE M6 6,4X18X1,5U6593 IX	SCHEIBE M6 6,4X18X1,5 U6593 IX	ARANDELA M6 6,4X18X1,5 6593IX
10	G19005140R	GUARNIZIONE FORO D.45	HOLE D.45 GASKET	JOINT D.45 FERME	DICHTUNG D.45 GESCHLO	JUNTA AGUJERO D.45
11	G16026580R	DISTRIBUTORE 40U LAVORATO	40E DISTRIBUTOR REWORKING			
12	G16025220R	COPERCHIO DISTRIBUTORE 48 24	DISTRIBUTOR COVER 48 24 OUT.			
13	G16025630R	COPERCHIO DISTRIBUTORE 48 12	DISTRIBUTOR COVER 48 12 OUT.			
14	G16025660R	COPERCHIO DISTRIBUTORE 40 10	DISTRIBUTOR COVER 40 10 OUT.			
15	G16024271R	COPERCHIO DISTRIBUT.40 20 COMP	DISTRIBUTOR COVER 40 20			
16	G22270190R	CATENA AGG.MOLLA SEGNAF. SP	CHAIN ADDITIONAL SPRING ROWMAR	CHAINE FIXATION RESS. TRACEUR	KETTE FEDERANSCHLUSS SPURREISS	CADENA CONEX. MUELLE MARC. FIL
17	G13649050R	CATENA GENOVESE D.2,8 L.295 ZN	GENOAN CHAIN D.2,8 L.295			
18	F01090203R	VITE M6X1X20 U5449 ZN	SCR. M6X1X20 U5449 ZN	VIS M 6X 1X 20 U5449 ZG	SCHRAUBE M 6X 1X 20 U5449	TORNIL. M 6X 1X 20 U5449
19	G16024620R	TUBO MISCELATORE L800	MIXER TUBE L800			
20	G16026450R	DIFFUSORE D.141-D.210	DIFFUSER D.141-D.210			
21	F01020362R	VITE M4X0,7X12 U5739 8.8ZN	SCR. M4X0,7X12 U5739 8.8ZN	VIS 4X12 5739 8.G ZN	SCHRAUBE 4X12 5739 8.G ZN	TORNILLO 4X12 5739 8.G ZN
22	F01230016R	DADO M4X0,7 D982 8ZN	NUT M4X0,7 D982 8ZN	ECROU AUTOB.NOR.4 ZN	SELBSTSP. MUTTER NOR. 4 ZN	TUERCA AUTOB. NOR. 4 ZN
23	F01020463R	VITE M10X1,5X25 U5739 A2IX	SCR. M10X1,5X25 U5739 A2IX	VIS 10X25 5739 INOX A2	SCHRAUBE 10X25 5739 INOX A2	TORNILLO 10X25 5739 INOX A2
24	F01230047R	DADO M10X1,5 D982 A2IX	NUT M10X1,5 D982 A2IX	ECROU M10X 1,5 D982 A2 IX	MUTTER M10X 1,5 D982 A2 IX	TUERCA M10X 1,5 D982 A2 IX
25	F01420059R	ROS.M10 10,5X 30X2,5 U6593 IX	WASHER 11X30X2,5 6593 A2	RONDELLE 11X30X2,5 6593 A2	UNTERLEGSCHLEIBE 11X30X2,5 6593	ARANDELA 11X30X2,5 6593 A2
26	G19007180R	GUARNIZIONE D.70 MM	GASKET D.70 MM			
27	F01030056R	VITE M8X1,25X25 U5933 10.9ZD	SCR. M8X1,25X25 U5933 10.9ZD	VIS 8X25 5933 10.9 ZN	SCHRAUBE 8X25 5933 10.9 ZN	TORNILLO 8X25 5933 10.9 ZN
28	F01420047R	ROS.M8 8,4X 24X 2 U6593 IX	WASHER M8 8,4X24X2 U6593 IX	RONDELLE M8 8,4X24X2 U6593 IX	SCHEIBE M8 8,4X24X2 U6593 IX	ARANDELA M8 8,4X24X2 U6593 IX
29	F01230032R	DADO M8X1,25 D982 A2IX	NUT M8X1,25 D982 A2IX	ECROU M 8X1,25 D982 A2 IX	MUTTER M 8X1,25 D982 A2 IX	TUERCA M 8X1,25 D982 A2 IX
30	F01020443R	VITE M8X1,25X25 U5739 A2IX	SCR. M8X1,25X25 U5739 A2IX	VIS M8X1.25X25 U5739 A2 IX	SCHRAUBE M8X1.25X25 5739 A2 IX	TORNILLO M8X1.25X25 5739 A2 IX
31	F02300021R	FASCETTA STRING. 40 60 H.8	STRING FASTEN.STRAPS 40 60 H.8	COLLIER DE SERRAGE 40 60 H.8	SHELLE 40 60 H.8	ABRAZADERA 40 60 H.8
32	F01200245R	DADO M8X1,25 U5588 A2IX	NUT M8X1,25 U5588 A2IX	ECROU M 8X1,25 U5588 A2 IX	MUTTER M 8X1,25 U5588 A2 IX	TUERCA M 8X1,25 U5588 A2 IX
33	G16023820R	TELO COPRITRAMOGGIA PINTA	HOPPERCOVER SHEET PINTA			
34	G16023080R	SUPPORTO POST.COPRITRAMOGGIA	REAR HOPPER COVER SUPPORT	SUPPORT POSTERIEUR COUVRE-TREM	HINTERE HALTERUNG TRICHTERAB.	SOPORTE TRASERO CUBIERTA TOLVA
35	G16026560R	DISTRIBUTORE 48U LAVORATO	48E DISTRIBUTOR REWORKING			
36	G13831460R	BOCCOLA LEVA CAMBIO INT.35 ZN	BUSHING CHANGE LEVER INT.35 ZN			
37	F02300018R	FASCETTA STRING. 25 40 H.8	CLAMP 25 40 H.8	GAIN 25 40 H.8	KLEMME 25 40 H.8	BRAZADERA 25 40 H.8
38	F03100530R	TUBO EOLO PU-P D.32	EOLO TUBE PU-P D.32	TUBE EOLO GALVANISE PP		
39	G17920041R	GUARNIZIONE	GASKET			
40	F02250705R	OCCHIELLO AGGANCIAMENTO ART.360	HOOK EYE	OEILLET D ACCROCHAGE	KUPPLUNGSTSE	ARGOLLA DE ENGANCHE
41	F01020071R	VITE M8X1,25X45 U5737 A2IX	SCR. M8X1,25X45 U5737 A2IX	VIS 8 X45 5737 8.G IX	SCHRAUBE 8 X45 5737 8.G IX	TORNILLO 8 X45 5737 8.G IX
42	F05150456R	PARACOLPI 30X15 M8X25	BUFFER 30X15 M8X25	PARE-CHOC 30X15 M8X25	STOSSDZMPFER 30X15 M8X25	PARAGOLPES 30X15 M8X25
43	F05150495R	TIRANTE IN GOMMA	RUBBER COUPLING TIE ROD	TRINGLE D ATTELAGE	KUPPLUNGSSPANNSTANGE	TIRANTE DE ENGANCHE
44	F01020012R	VITE M4X0,7X40 U5737 8.8ZN	SCR. M4X0,7X40 U5737 8.8ZN	VIS 4X40 5737 8.G ZN	SCHRAUBE 4X40 5737 8.G ZN	TORNILLO 4X40 5737 8.G ZN
45	F01420011R	ROS.M4 4,3X 16X 1 U6593 ZN	FLAT WASHER 4-3X 16X1-5 6593 G	ROND.PLATE 4-3X 16X1-5 6593 ZN	SCHEIBE 4-3X 16X1-5 6593 ZN	ARAND. PLANA 4-3X 16X1-5 6593
46	F01230024R	DADO M6X1 D982 A2IX	NUT M6X1 D982 A2IX	ECROU AUTOB.NOR.10	SELBSTSP. MUTTER NOR. 10	TUERCA AUTOB. NOR. 10
47	F01020419R	VITE M 6X1 X 16 U5739 A2IX	SCR. M6X1X16 U5739 A2IX	VIS M6 X1 X 16 U5739 8.8 IX	SCHRAUBE M6 X1 X 16 U5739 8.	TORNIL. M6 X1 X 16 U5739 8.8
48	G17920200R	COPERCHIO DISTRIBUTORE 40 U.	DISTRIBUTOR COVER 40 OUTPUTS	COUVERCLE DISTRIBUTEUR 40 SORT	DECKEL SZAPPARAT 40 AUSGZNG	TAPA DISTRIBUIDOR 40 SALIDAS
49	F03100493R	TUBO EOLO PU 52	EOLO PIPE 50	TUBE EOLO 50	ROHR EOLO 50	TUBO EOLO 50
50	F05150399R	CORDA POLIPROPILENE D.12	POLIPR. D.12 ROPE			
51	G19004350R	MANICOTTO PIEGATO	BEND SLEEVE			
52	F05150361R	RIDUZIONE	REDUCTION			

«Seme/Seed»

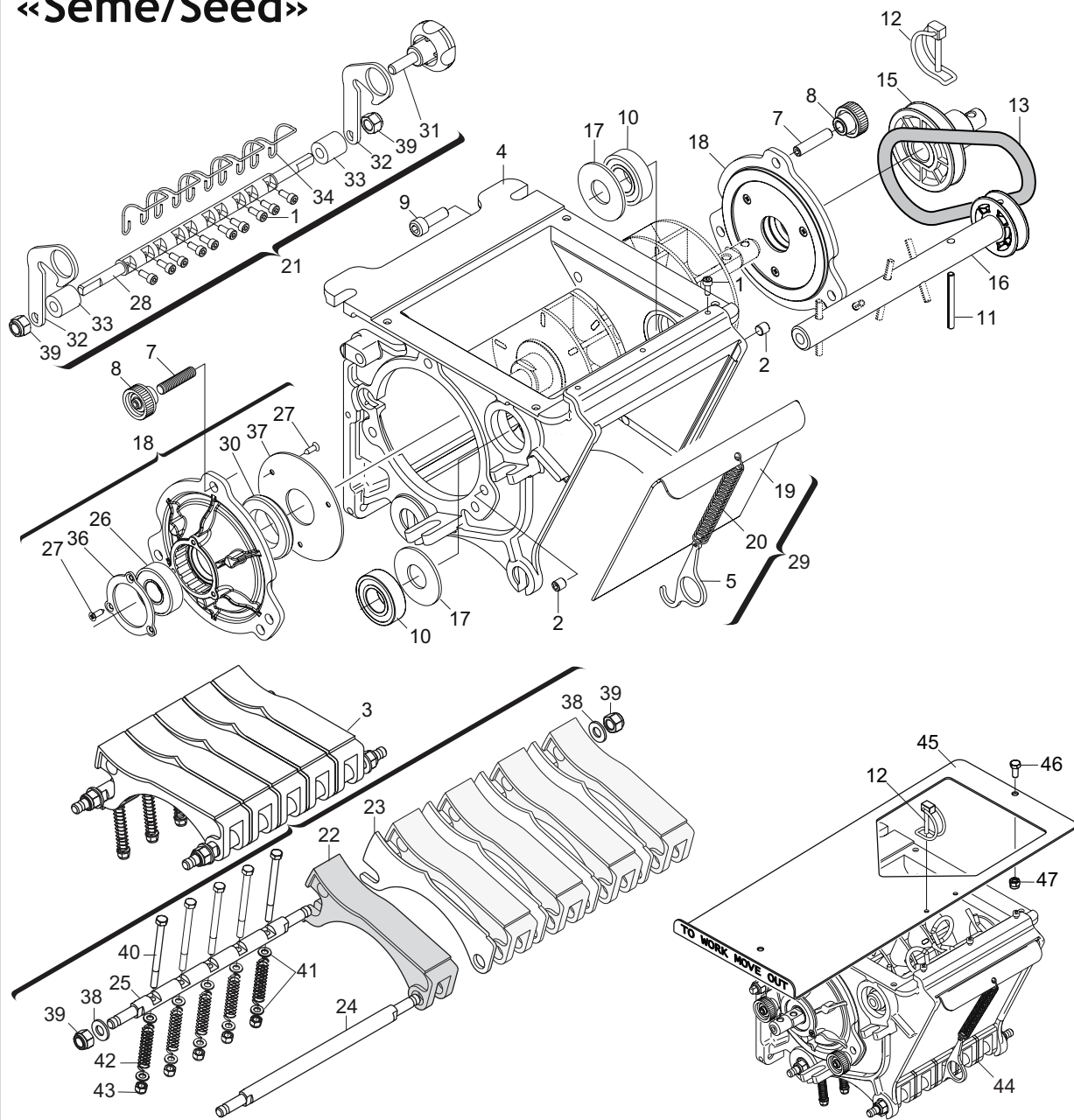

Semente Normale - Normal Seeds

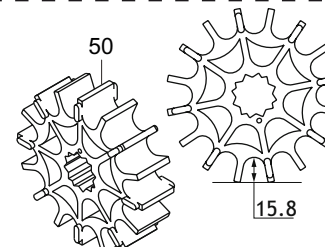
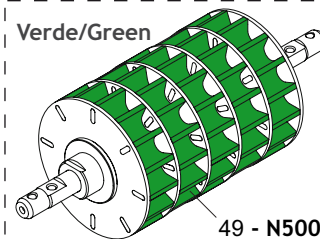
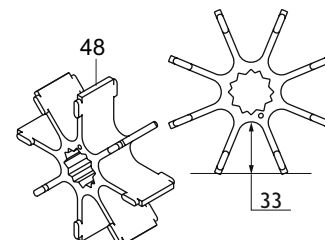
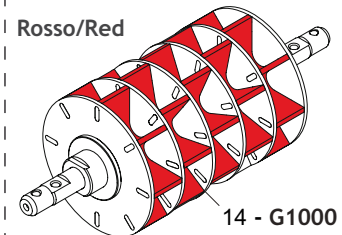

Semente Grossa (Piselli - Ceci - etc.)
Large Seeds (Peas - Pulses - etc.)

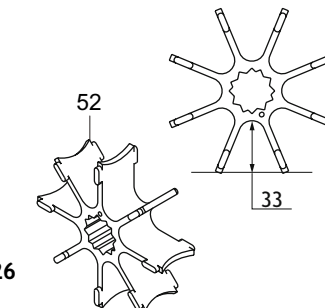
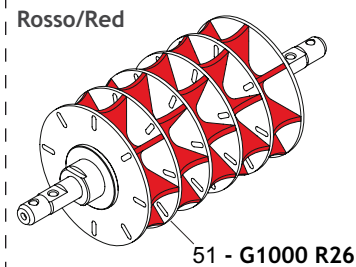

Semente Piccola
Small Seeds

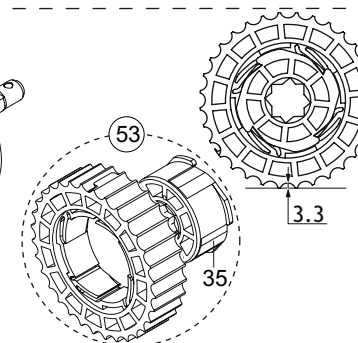
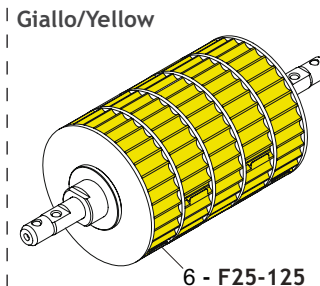

DOSATORE SEME SEED DOSER

TAV. 050

Pos.	Cod.	Descrizione	Description	Description	Benennung	Description
1	F01040026R	VITE M4X0,7X10 U5931 A2IX	SCR. M4X0,7X10 U5931 A2IX	VIS 4X10 5931 INOX A2	SCHRAUBE 4X10 5931 INOX A2	TORNILLO 4X10 5931 INOX A2
2	F01050037R	VITE M8X1,25X10 U5923 8.8BR	SCR. M8X1,25X10 U5923 8.8BR	GOUJON 8X10 5923 12.9	STIFT 8X10 UNI 5923 12.9	TORNILLO SIN CABEZA 8X10 5923
3	G16060030R	TASTATORE COMPL.	COMPL. FEELER PIN	T-TEUR COMPL.	ABTASTER KOMPL.	PALPADOR COMPL.
4	G16127230R	CORPO DISTRIBUTORE UNIFICATO	DISTRIB.BODY STANDARD			
5	G16060170R	GANCIO INOX	HOOK INOX			
6	G16123821R	MONT.RULLO F25-125 STAGNO IND.	F25-125 INDUCT.DOSER ROLLER			
7	F01050040R	VITE M8X1,25X35 U5923 A2IX	SCR. M8X1,25X35 U5923 A2IX	GOUJON 8X35 5923	STIFT 8X35 UNI 5923	TORNILLO SIN CABEZA 8X35 5923
8	F06220037R	VOLANTINO ZIGR.D.26-M8 FEM	KNURLED HANDWHEEL D.26-M8			FOLLETO ZIGR.D.26-M8
9	F01040090R	VITE M8X1,25X18 U5931 A2IX	SCR. M8X1,25X18 U5931 A2IX	VIS M8X1,25X 18 U5931 IX A2	SCHRAUBE M8X1,25X 18 U5931 IX	TORNIL. M8X1,25X 18 U5931 IX
10	F04010132R	CUSC.D20 D42 B12 6004 2RSIX	BEARING D20 D42 B12 6004 2R			
11	F02100316R	SPINA EL.5 X50 DIN 1481 INOX	EL.PIN 5 X50 DIN 1481 INOX			
12	F02200595R	SPINA SICUR.D. 5X30 ZN	PIN X GEAR	GOUJON	BOLZEN	ESPINA
13	F03011142R	GUARNIZIONE OR 10 X 100 EPDM	O-RING GASKET 10X100	JOINT TORIQUE 10X100	DICHTUNG OR 10X100	JUNTA T RICA OR 10X100
14	G16123750R	MONT.RULLO G1000 STAGNO	ROLLER SUPPORT G1000			
15	G16125241R	MONT.ALBERO TRASCIN.RULLO	SHAFT DRIVE ROLLER			
16	G16124421R	MONT.ALBERO AGITATORE	AGITATOR SHAFT			
17	G18701920R	RONDELLA 20X48X2,5	WASHER 20X48X2,5	RONDELLE 20X48X2,5	UNTERLEGSCHIEBE 20X48X2,5	ARANDELA 20X48X2,5
18	G16124511R	MONT.FLANGIA PORTA CUSC.RULLO	FLANGE SUPP.ROLLER BEARING			
19	G16060160R	SPORTELLO GRANDE INOX	LARGE HATCH	PORTILLON GRAND	GROSSE KLAPPE	PORTILLO GRANDE
20	G18904170R	MOLLA SPORTELLO GRANDE	SPRING BIG-DOOR			
21	G16060040R	PULITORE COMPL	ANTI CLOGGING	ANTI-ENGORGEMENT	VERSTOPFUNGSHEMMENDES EL.	ANTI OBSTRUCCIN
22	G19004660R	TASTATORE	FEELER PIN			
23	G16060120R	SPESSORE TASTATORE INOX	SHIMS	CALE	ZWISCHENLEGSCHIEBE	ESPACIADOR
24	G16060130R	ALBERO TASTATORE INOX	FEELER PIN	TATEUR	ABTASTER	PALPADOR
25	G16060140R	ALBERO BLOCCAGGIO TASTATORE A2	SHAFT	ARBRE	WELLE	EJE
26	F04010161R	CUSC.D17 D40 B12 6203 2RS EX	BEARING D17 D40 B12 6203 2RS	ROULEMENT 6203 2RS	LAGER 6203 2RS	COJINETE 6203 2RS SKF
27	F01070122R	VITE A3,9X1,34X13 U6955 4.8NI	SCR. H3,9X1,34X13 U6955 4.8NI	VIS M3,9X1,34X13 U6955 4.8NI	SCHRA.M3,9X1,34X13 U6955 4.8NI	TORN.M3,9X1,34X13 U6955 4.8NI
28	G16060220R	ALBERO PULITORE INOX	ANTI CLOGGING SHAFT	ARBRE ANTI-ENGORGEMENT	WELLE VERSTOPFUNGSHEMMENDES	EJE ANTI OBSTRUCCION
29	G16060050R	SPORTELLO GRANDE COMPL.	LARGE DOOR COMPL.			
30	F03010062R	ANEL. T.A 30X 52X 7 HMS4R	SEALING RING 30X 52X 7	BAGUE D ETANCHEITE 30X 52X 7	DICHTUNGSRING 30X 52X 7	ANILLO AISLADOR 30X 52X 7
31	F06220019R	VOLANTINO 4L.VTPX 40 M8X25 IX	4-LOBE HANDWHEEL M8X25	VOLANT 4 LOBES M8X25	HANDRAD 4 BUCKEL M8X25	VOLANTE 4 LOBI M8X25
32	G16060210R	LEVA ALBERO PULITORE	LEVER	LEVIER	HEBEL	PALANCA
33	G18802500R	BUSSOLA BRONZO 17X8X19	BOLT 17X8X19	BOULON 17X8X19	SCHRAUBE 17X8X19	PERNO 17X8X19
34	G18904160R	MOLLA PULITORE	SPRING			
35	G19004830R	RUOTA F25 INTERNA	INTERNALWHEEL F25			
36	G16126880R	FERMO CUSCINETTO IX	BEARING LOCK IX			
37	G16125691R	PROTEZIONE POST.PARAPOLVERE IX	DUSTCOVER REAR GUARD FRD 210			
38	F01410050R	ROS.M8 8,4X 17X1,6 U6592 IX	WASHER M8 8,4X 17X1,6 U6592 IX	RONDELLE M8 8,4X 17X1,6 IX	SCHEIBE M8 8,4X 17X1,6 IX	ARANDELA M8 8,4X 17X1,6 IX
39	F01230032R	DADO M8X1,25 D982 A2IX	NUT M8X1,25 D982 A2IX	ECROU M 8X1,25 D982 A2 IX	MUTTER M 8X1,25 D982 A2 IX	TUERCA M 8X1,25 D982 A2 IX
40	F01020385R	VITE M5X0,8X60 U5737 A2IX	SCR. M5X0,8X60 U5737 A2IX	VIS M5X 0,8X 60 U5739 8.8 IX	SCHRAUBE M5X0,8X60 U5739 8.8IX	TORNIL. M5X0,8X60 U5739 8.8 IX
41	F01410022R	ROS.M5 5,3X 10X 1 U6592 IX	WASHER M5 5,3X10X 1 U6592 IX			
42	G18904150R	MOLLA TASTATORE	TRACER POINT SPRING			
43	F01230020R	DADO M5X0,8 D982 A2IX	NUT M5X0,8 D982 A2IX	ECROU M5X0,8 D982 A2 IX	MUTTER M5X0,8 D982 A2 IX	TUERCA M5X0,8 D982 A2 IX
44	G16127241R	DOSATORE SEME DX UNIF.FRES.IND	IND.RIGHT SEED DOSER UNIF.MIL.			
45	G17922840R	GHIGLIOTTINA IX DOSATORE	GUILLOTTINE IX DOSER			
46	F01020418R	VITE M6X1X14 U5739 A2IX	SCR. M6X1X14 U5739 A2IX	VIS 6X14 5739 INOX A2	SCHRAUBE 6X14 5739 INOX A2	TORNILLO 6X14 5739 INOX A2
47	F01230024R	DADO M6X1 D982 A2IX	NUT M6X1 D982 A2IX	ECROU AUTOB.NOR.10	SELBSTSP. MUTTER NOR. 10	TUERCA AUTOB. NOR. 10
48	G16063060R	RUOTA G200	WHEEL G200			
49	G16123831R	MONT.RULLO N500 STAGNO IND.	ROLLER SUPPORT N500			
50	G16063100R	RUOTA N100	WHEEL N100			
51	G16127281R	RULLO G1000 R26 STAGNO INDUT.	IND.HERM. G1000 R26 ROLLER			
52	G16063140R	RUOTA G200 R26,5	WHEEL G200 R26,5			
53	G16063030R	RUOTA F25	WHEEL F376			

«Concime/Fertilizer»

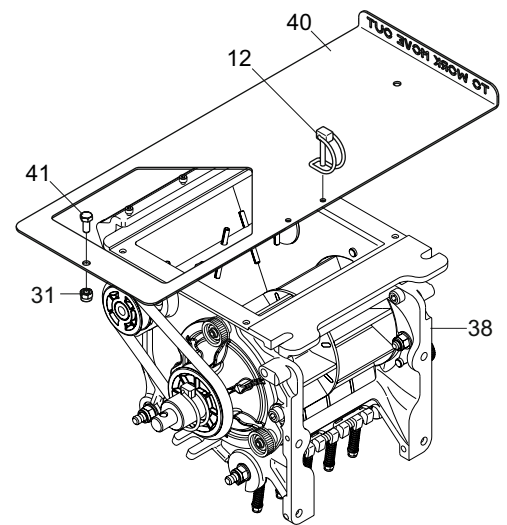
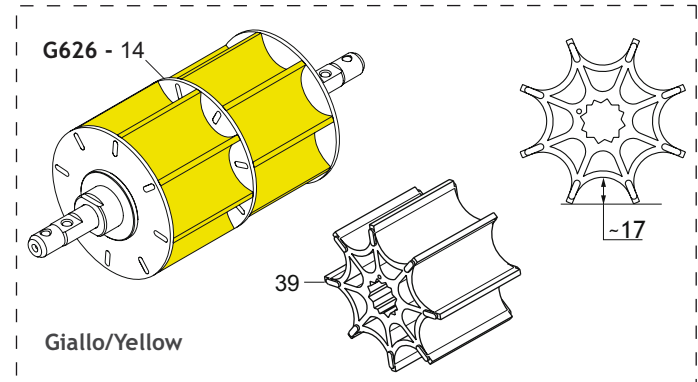
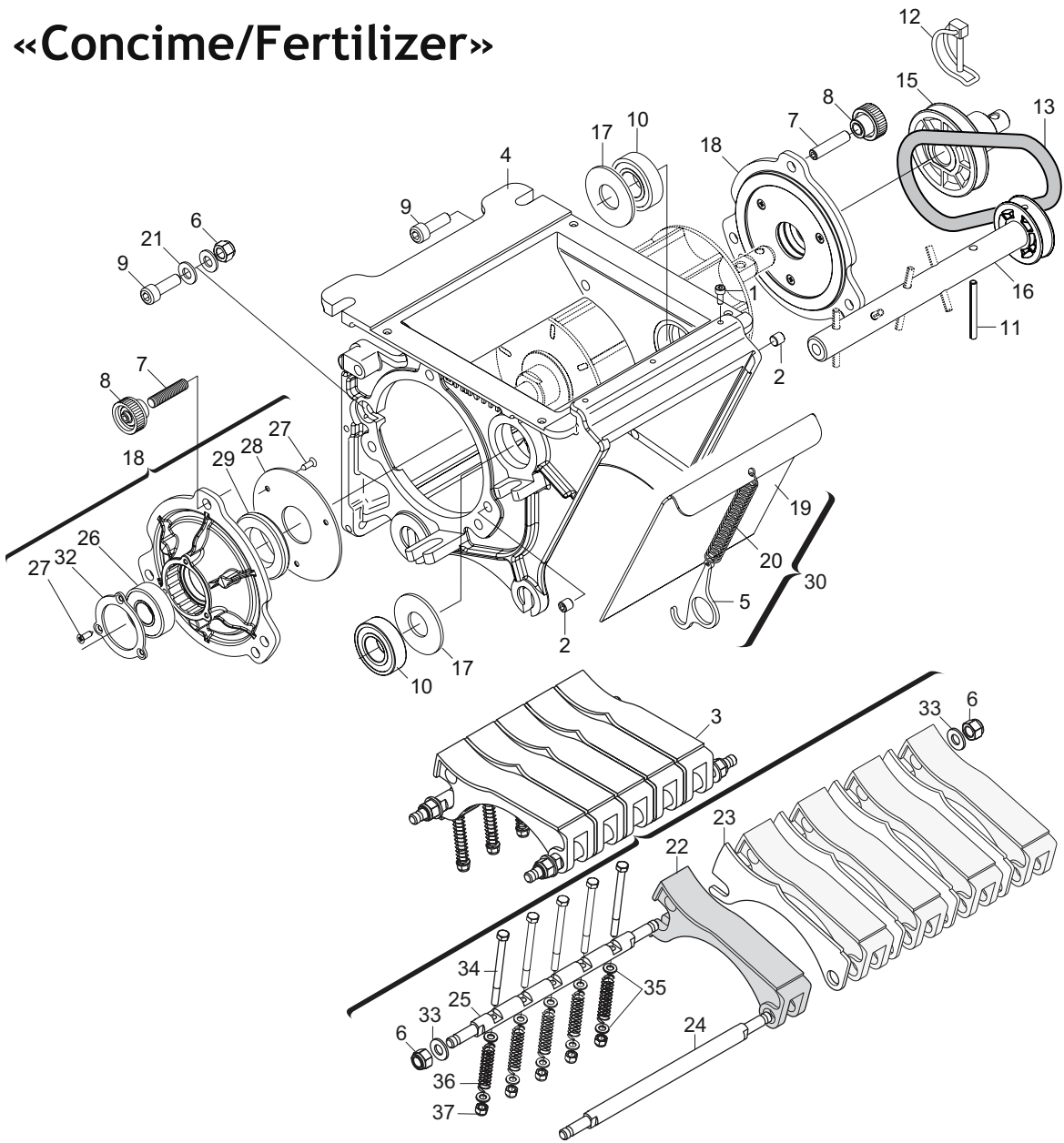

**DOSATORE CONCIME
FERTILIZER DOSER**

TAV. 080

Pos.	Cod.	Descrizione	Description	Description	Benennung	Description
1	F01040026R	VITE M4X0,7X10 U5931 A2IX	SCR. M4X0,7X10 U5931 A2IX	VIS 4X10 5931 INOX A2	SCHRAUBE 4X10 5931 INOX A2	TORNILLO 4X10 5931 INOX A2
2	F01050037R	VITE M8X1,25X10 U5923 8.8BR	SCR. M8X1,25X10 U5923 8.8BR	GOUJON 8X10 5923 12.9	STIFT 8X10 UNI 5923 12.9	TORNILLO SIN CABEZA 8X10 5923
3	G16060030R	TASTATORE COMPL.	COMPL. FEELER PIN	T-TEUR COMPL.	ABTASTER KOMPL.	PALPADOR COMPL.
4	G16127230R	CORPO DISTRIBUTORE UNIFICATO	DISTRIB.BODY STANDARD			
5	G16060170R	GANCIO INOX	HOOK INOX			
6	F01230032R	DADO M8X1,25 D982 A2IX	NUT M8X1,25 D982 A2IX	ECROU M 8X1,25 D982 A2 IX	MUTTER M 8X1,25 D982 A2 IX	TUERCA M 8X1,25 D982 A2 IX
7	F01050040R	VITE M8X1,25X35 U5923 A2IX	SCR. M8X1,25X35 U5923 A2IX	GOUJON 8X35 5923	STIFT 8X35 UNI 5923	TORNILLO SIN CABEZA 8X35 5923
8	F06220037R	VOLANTINO ZIGR.D.26-M8 FEM	KNURLED HANDWHEEL D.26-M8			FOLLETO ZIGR.D.26-M8
9	F01040090R	VITE M8X1,25X18 U5931 A2IX	SCR. M8X1,25X18 U5931 A2IX	VIS M8X1,25X 18 U5931 IX A2	SCHRAUBE M8X1,25X 18 U5931 IX	TORNIL. M8X1,25X 18 U5931 IX
10	F04010132R	CUSC.D20 D42 B12 6004 2RSIX	BEARING D20 D42 B12 6004 2R			
11	F02100316R	SPINA EL.5 X50 DIN 1481 INOX	EL.PIN 5 X50 DIN 1481 INOX			
12	F02200595R	SPINA SICUR.D. 5X30 ZN	PIN X GEAR	GOUJON	BOLZEN	ESPINA
13	F03011142R	GUARNIZIONE OR 10 X 100 EPDM	O-RING GASKET 10X100	JOINT TORIQUE 10X100	DICHTUNG OR 10X100	JUNTA T RICA OR 10X100
14	G16124151R	RULLO G626 STAGNO COMPL.IND.	IND.HERM. G626 ROLLER COMPL.			
15	G16125241R	MONT.ALBERO TRASCIN.RULLO	SHAFT DRIVE ROLLER			
16	G16124421R	MONT.ALBERO AGITATORE	AGITATOR SHAFT			
17	G18701920R	RONDELLA 20X48X2,5	WASHER 20X48X2,5	RONDELLE 20X48X2,5	UNTERLEGSSCHEIBE 20X48X2,5	ARANDELA 20X48X2,5
18	G16124511R	MONT.FLANGIA PORTA CUSC.RULLO	FLANGE SUPP.ROLLER BEARING			
19	G16060160R	SPORTELLO GRANDE INOX	LARGE HATCH	PORTILLON GRAND	GROSSE KLAPPE	PORTILLO GRANDE
20	G18904170R	MOLLA SPORTELLO GRANDE	SPRING BIG-DOOR			
21	F01410050R	ROS.M8 8,4X 17X1,6 U6592 IX	WASHER M8 8,4X 17X1,6 U6592 IX	RONDELLE M8 8,4X 17X1,6 IX	SCHEIBE M8 8,4X 17X1,6 IX	ARANDELA M8 8,4X 17X1,6 IX
22	G19004660R	TASTATORE	FEELER PIN			
23	G16060120R	SPESSORE TASTATORE INOX	SHIMS	CALE	ZWISCHENLEGSSCHEIBE	ESPACIADOR
24	G16060130R	ALBERO TASTATORE INOX	FEELER PIN	TATEUR	ABTASTER	PALPADOR
25	G16060140R	ALBERO BLOCCAGGIO TASTATORE A2	SHAFT	ARBRE	WELLE	EJE
26	F04010161R	CUSC.D17 D40 B12 6203 2RS EX	BEARING D17 D40 B12 6203 2RS	ROULEMENT 6203 2RS	LAGER 6203 2RS	COJINETE 6203 2RS SKF
27	F01070122R	VITE A3,9X1,34X13 U6955 4.8NI	SCR. H3,9X1,34X13 U6955 4.8NI	VIS M3,9X1,34X13 U6955 4.8NI	SCHRA.M3,9X1,34X13 U6955 4.8NI	TORN.M3,9X1,34X13 U6955 4.8NI
28	G16125691R	PROTEZIONE POST.PARAPOLVERE IX	DUSTCOVER REAR GUARD FRD 210			
29	F03010062R	ANEL. T.A 30X 52X 7 HMS4R	SEALING RING 30X 52X 7	BAGUE D ETANCHEITE 30X 52X 7	DICHTUNGSRING 30X 52X 7	ANILLO AISLADOR 30X 52X 7
30	G16060050R	SPORTELLO GRANDE COMPL.	LARGE DOOR COMPL.			
31	F01230024R	DADO M6X1 D982 A2IX	NUT M6X1 D982 A2IX	ECROU AUTOB.NOR.10	SELBSTSP. MUTTER NOR. 10	TUERCA AUTOB. NOR. 10
32	G16126880R	FERMO CUSCINETTO IX	BEARING LOCK IX			
33	G18904150R	MOLLA TASTATORE	TRACER POINT SPRING			
34	F01020385R	VITE M5X0,8X60 U5737 A2IX	SCR. M5X0,8X60 U5737 A2IX	VIS M5X 0,8X 60 U5739 8.8 IX	SCHRAUBE M5X0,8X60 U5739 8.8IX	TORNIL. M5X0,8X60 U5739 8.8 IX
35	F01410022R	ROS.M5 5,3X 10X 1 U6592 IX	WASHER M5 5,3X10X 1 U6592 IX			
36	F01410050R	ROS.M8 8,4X 17X1,6 U6592 IX	WASHER M8 8,4X 17X1,6 U6592 IX	RONDELLE M8 8,4X 17X1,6 IX	SCHEIBE M8 8,4X 17X1,6 IX	ARANDELA M8 8,4X 17X1,6 IX
37	F01230020R	DADO M5X0,8 D982 A2IX	NUT M5X0,8 D982 A2IX	ECROU M5X0,8 D982 A2 IX	MUTTER M5X0,8 D982 A2 IX	TUERCA M5X0,8 D982 A2 IX
38	G16127261R	DOSATORE CONC.DX UNIF.FRES.IND	RIGHT FERTIL.BATCHER STANDARD			
39	G16063070R	RUOTA G313	WHEEL G313			
40	G17922840R	GHIGLIOTTINA IX DOSATORE	GUILLOTTINE IX DOSER			
41	F01020418R	VITE M6X1X14 U5739 A2IX	SCR. M6X1X14 U5739 A2IX	VIS 6X14 5739 INOX A2	SCHRAUBE 6X14 5739 INOX A2	TORNILLO 6X14 5739 INOX A2

«Seme/Seed»

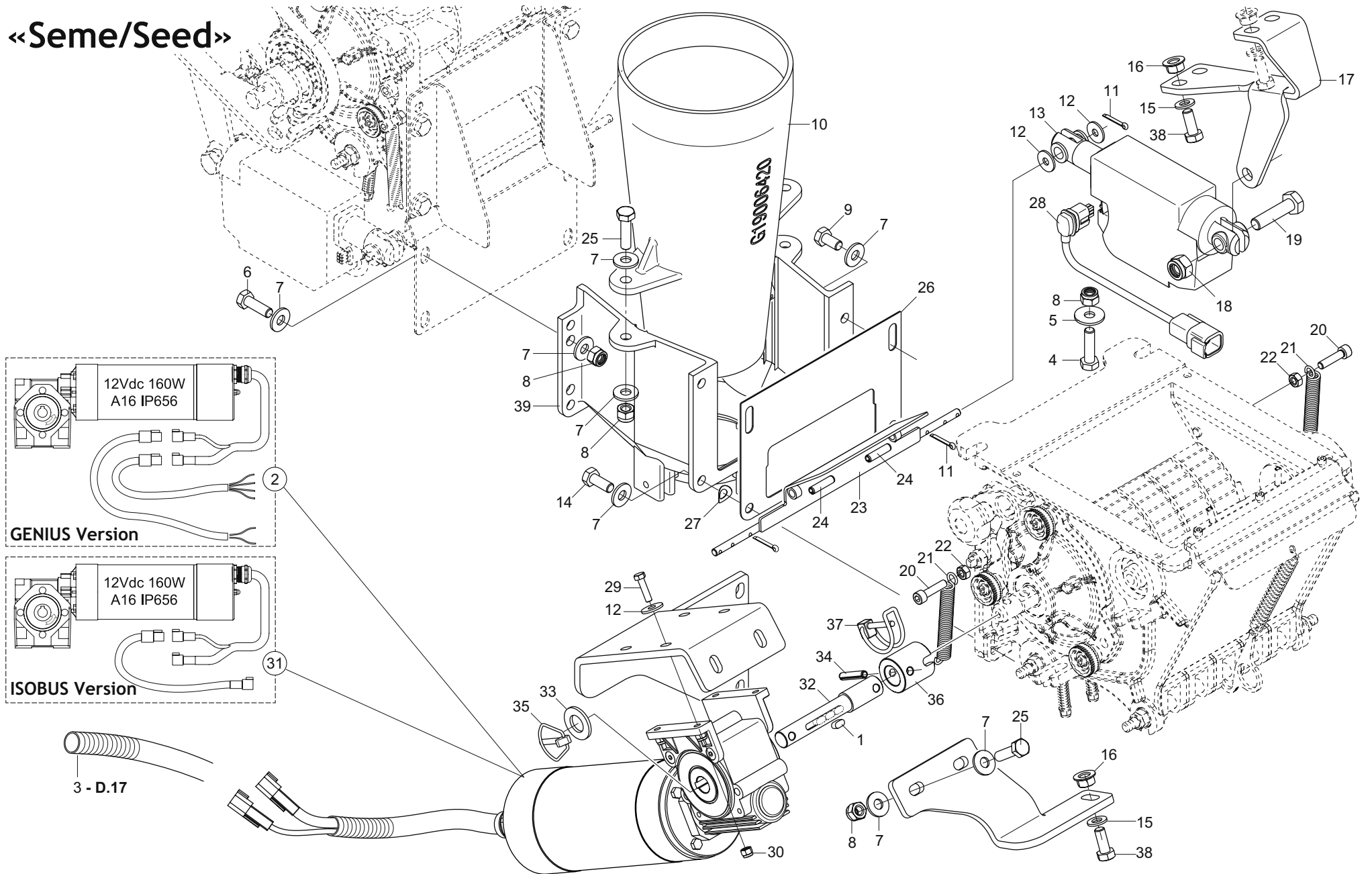

**AZIONAMENTO ELETTRICO DOSATORE SEME
ELECTRIC SEED DOSING**

TAV. 090

Pos.	Cod.	Descrizione	Description	Description	Benennung	Description
1	F02150012R	LINGUETTA 05X5X10 UNI6604	PARALLEL KEY 5X 5X 10 U6604A			
2	F05010545R	MOTORIDUTTORE 12V-157W 50 1	REDUCTION 12V-157W 50 1			
3	F05010020R	GUAINA CORRUGATA D.17 NERA	ROUGH SHEATH D.17 BLACK			
4	F01020445R	VITE M8X1,25X30 U5739 8.8ZN	SCR. M8X1,25X30 U5739 8.8ZN	VIS M 8X1,25X30 U5739 8.8 ZN	SCHRAU, M8X1,25X30 U5739 8.8ZN	TORN. M8X1,25X30 U5739 8.8 ZN
5	F01420048R	ROS.M8 8,4X 24X 2 U6593 ZN	WASHER M8 8,4X 24X2 U6593 ZN	RONDELLE M8 8,4X24X 2 U6593 ZN	SCHLEIBEN M8 8,4X24X 2 U6593 ZN	ARANDELA M8 8,4X 24X2 U6593 ZN
6	F01020440R	VITE M8X1,25X25 U5739 8.8ZN	SCR. M8X1,25X25 U5739 8.8ZN	VIS M8X1,25X25 U5739 8.8 ZN	SCHRAUBE M8X1,25X25U5739 8.8ZN	TORNIL.M8X1,25X25 U5739 8.8 ZN
7	G20970140R	RONDELLA 20X2X8,5	WASHER 20X2X8,5	RONDELLE 20X2X8,5	UNTERLEGSCHLEIBE 20X2X8,5	ARANDELA 20X2X8,5
8	F01230034R	DADO M8X1,25 D982 8ZN	NUT M8X1,25 D982 8ZN	ECROU M8X 1,25 ZN	MUTTER M8X 1,25 D982 8 ZN	TUERCA M8X 1,25 D982 8 ZN
9	F01020432R	VITE M8X1,25X16 U5739 8.8ZN	SCR. M8X1,25X16 U5739 8.8ZN	VIS M8 X1,25X16 U5739 8.8 ZN	SCHRAUBE M8X1,25X16U5739 8.8ZN	TORNILLO M8X1,25X16U5739 8.8ZN
10	G19006420R	CONO DIFFUSORE D.140	SPEAKER CONE D.140			
11	F02200162R	COPIGLIA 3X 20 U1336 ZN	SPLIT PIN 3 X20 1336 GALVAN.	GOUPILLE 3 X20 1336 ZN	SPLINT 3 X20 1336 ZN	PASADOR 3 X20 1336 ZN
12	F01420038R	ROS.M6 6,4X18X1,5 U6593 IX	WASHER M6 6,4X18X1,5 U6593 IX	RONDELLE M6 6,4X18X1,5U6593 IX	SCHLEIBE M6 6,4X18X1,5 U6593 IX	ARANDELA M6 6,4X18X1,5 6593IX
13	F05011897R	KIT ATT.LINAK LA23 C.20MM-CABL	KIT ATT LINAK LA23 C 20MM-CABL			
14	F01020436R	VITE M8X1,25X20 U5739 8.8ZN	SCR. M8X1,25X20 U5739 8.8ZN	VIS M8X1,25X 20 U5739 8.8 ZN	SCHRAUBE M8X1,25X20U5739 8.8ZN	TORN. M8X1,25X20 U5739 8.8 ZN
15	F01410051R	ROS.M8 8,4X 17X1,6 U6592 ZN	WASHER M8 8,4X17X1,6 U6592 ZN	RONDELLE M8 8,4X17X1,6 ZN	SCHLEIBE M8 8,4X17X1,6 U6592 ZN	ARANDELA M8 8,4X17X1,6 U6592ZN
16	F01260043R	DADO M8 D6923 8.8ZN	NUT M8 D6923 8.8ZN	ECROU BRIDE .M8 DIN 6923 8.8 Z	GEFLANSCHTE MUTTER M8 DIN6923	TUERCA BRIDA M8 DIN 6923 8.8 Z
17	G17922761R	LAMA SUPP.LINAK	LINAK SUPPORT			
18	F01230048R	DADO M10X1,5 D982 8ZN	NUT M10X1,5 D982 8ZN	ECR.AUTO-FREIN.M10X1,5 D982 ZN	SICHERUNGSMUTT.M10X1,5 D982 ZN	TUERCA SEGURID.M10X1,5 D982 ZN
19	F01020483R	VITE M10X1,5X40 U5739 10.9ZD	SCR. M10X1,5X40 U5739 10.9ZD	VIS M10X1,5X40 U5739 10.9 ZD	SCHRA.M10X1,5X40 U5739 10.9 ZD	TORN. M10X1,5X40 U5739 10.9 ZD
20	F01040064R	VITE M6X1X25 U5931 8.8ZN	SCREW M6X1X25 U5931 8.8ZN	VIS M6X1X25 U5931 8.8ZN	SCHRAUBE M6X1X25 U5931 8.8ZN	TORNILLO M6X1X25 U5931 8.8ZN
21	G18901771R	MOLLA TRAZ.RUOTA DP IX	TRACTION WHEEL SPRING DP IX			
22	F01200233R	DADO M6X1 U5588 A2IX	NUT M6X1 U5588 A2IX	ECROU M 6X 1 U5588 I	MUTTER M 6X 1 U5588	TUERCA M 6X 1 U5588
23	G17922270R	PORTELLINO PROVA SEMINA IX	TEST SEEDING IX HANDHOLE			
24	F02100111R	SPINA E.P. 6X 24 U6873 A2 IX	PIN EL. 6 X24 U6873 A2 IX			
25	F01020445R	VITE M8X1,25X30 U5739 8.8ZN	SCR. M8X1,25X30 U5739 8.8ZN	VIS M 8X1,25X30 U5739 8.8 ZN	SCHRAU, M8X1,25X30 U5739 8.8ZN	TORN. M8X1,25X30 U5739 8.8 ZN
26	G17922350R	LAMA BLOCCO USCITA SEME IX	BLADE STOP SEEDS WAY OUT			
27	F01460115R	ROS.OND. 8,4X 15X0,5 BR D137A	WASHER D8 DIN 137 A	RONDELLE D8 DIN 137 A	UNTERLEGSCHLEIBE D8 DIN 137 A	ARANDELA D8 DIN 137 A
28	F05200665R	CABL.COLLEGAMENTO LINAK	CABLE CONNECTION LINAK			
29	F01020381R	VITE M5X0,8X20 U5739 A2IX	SCR. M5X0,8X20 U5739 A2IX	VIS 5X20 5739	SCHRAUBE 5X20 5739	TORNILLO 5X20 5739
30	F01230020R	DADO M5X0,8 D982 A2IX	NUT M5X0,8 D982 A2IX	ECROU M5X0,8 D982 A2 IX	MUTTER M5X0,8 D982 A2 IX	TUERCA M5X0,8 D982 A2 IX
31	F05011172R	MOTORID.12V-157W 50 1 C.CONN.	RATIOMOTOR 12V-157W 50 1			
32	G16035710R	ALBERO TRASM.MOTORE ELETTRICO	ELECTRIC ENGINE TRANSM.SHAFT			
33	F01410088R	ROS.M14 15X 28X2,5 U6592 ZN	WAS.M14 15X 28X2,5 U6592 ZB	RON.M14 15X 28X2,5 U6592 ZB	SCH.M14 15X 28X2,5 U6592 ZB	ARA.M14 15X 28X2,5 U6592 ZB
34	F02100115R	SPINA E.P. 6X 30 U6873 C70 IX	PIN EL. 6X30 DIN 1481 S.STEEL*	GOUPILLE EL.6 X30 DIN 1481 IN	SPANNSTIFT 6 X30 DIN 1481 EDEL	CLAVIJA EL.6 X30 DIN 1481 INO
35	F02200452R	SPINA SCATTO D.4,4 B 80 ZN	SNAP PIN D4.4 B 80 ZN	FICHE A DETENTE D4.4 B 80 ZN	EINRASTSTIFT D4.4 B 80 ZN	CLAVIJA DE MUELLE D4,4 B 80 ZN
36	G16130860R	BOCCOLA UNIONE CAMBIO-DOS.STA.	GEAR JUNCTION BUSHING			
37	F02200595R	SPINA SICUR.D. 5X30 ZN	PIN X GEAR	GOUJON	BOLZEN	ESPINA
38	F01020432R	VITE M8X1,25X16 U5739 8.8ZN	SCR. M8X1,25X16 U5739 8.8ZN	VIS M8 X1,25X16 U5739 8.8 ZN	SCHRAUBE M8X1,25X16U5739 8.8ZN	TORNILLO M8X1,25X16U5739 8.8ZN
39	G16025050R	CORPO VENTURI ABBASSATO 15MM	15 MM LOWERED VENTURI CASING			

«Concime/Fertilizer»

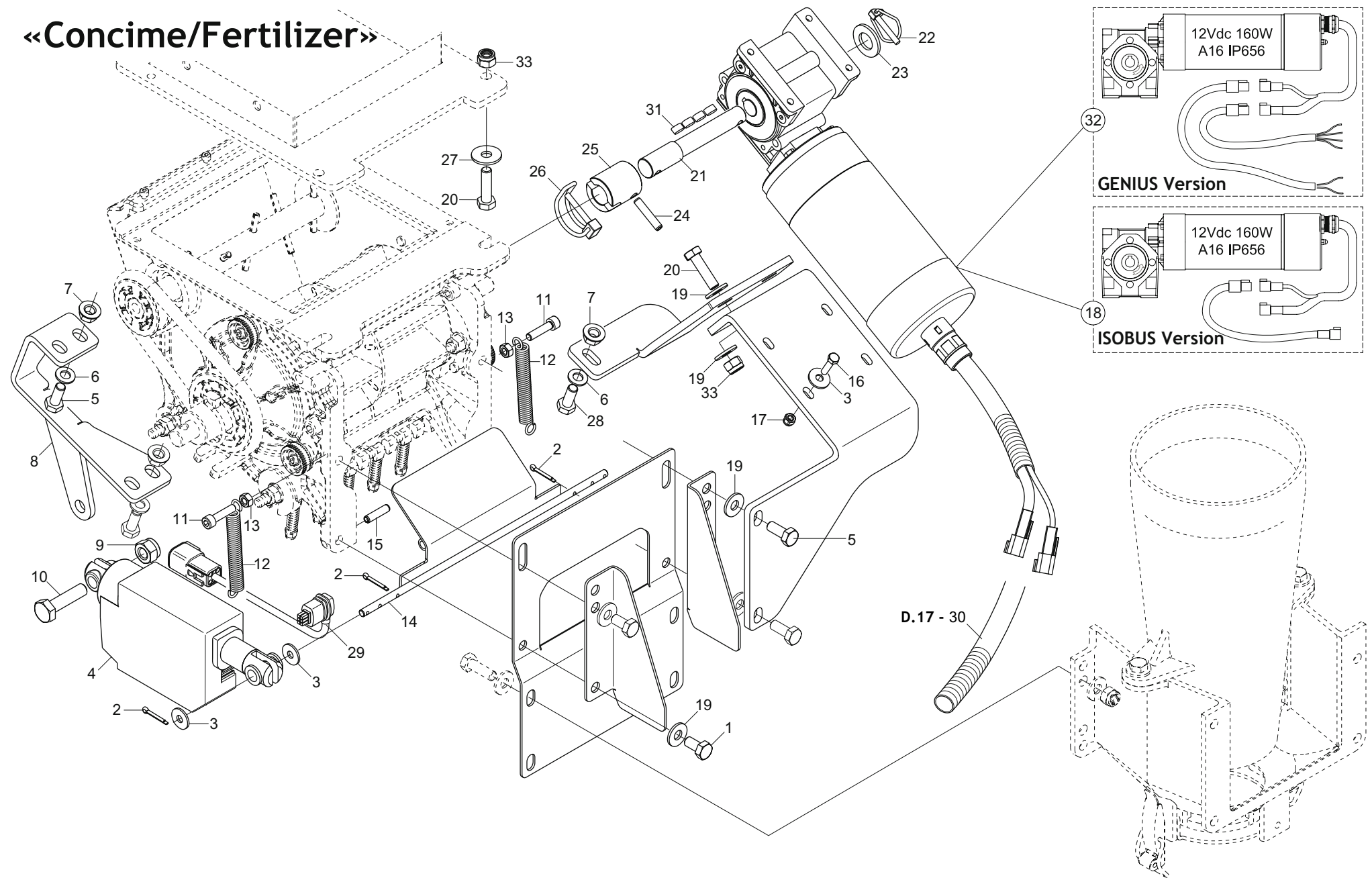

**AZIONAMENTO ELETTRICO DOSATORE CONCIME
ELECTRIC FERTILIZER DOSING**

TAV. 100

Pos.	Cod.	Descrizione	Description	Description	Benennung	Descripcion
1	F01020432R	VITE M8X1,25X16 U5739 8.8ZN	SCR. M8X1,25X16 U5739 8.8ZN	VIS M8 X1,25X16 U5739 8.8 ZN	SCHRAUBE M8X1,25X16U5739 8.8ZN	TORNILLO M8X1,25X16U5739 8.8ZN
2	F02200162R	COPIGLIA 3X 20 U1336 ZN	SPLIT PIN 3 X20 1336 GALVAN.	GOUPILLE 3 X20 1336 ZN	SPLINT 3 X20 1336 ZN	PASADOR 3 X20 1336 ZN
3	F01420038R	ROS.M6 6,4X18X1,5 U6593 IX	WASHER M6 6,4X18X1,5 U6593 IX	RONDELLE M6 6,4X18X1,5U6593 IX	SCHEIBE M6 6,4X18X1,5 U6593 IX	ARANDELA M6 6,4X18X1,5 6593IX
4	F05011897R	KIT ATT.LINAK LA23 C.20MM-CABL	KIT ATT LINAK LA23 C 20MM-CABL			
5	F01020436R	VITE M8X1,25X20 U5739 8.8ZN	SCR. M8X1,25X20 U5739 8.8ZN	VIS M8X1,25X 20 U5739 8.8 ZN	SCHRAUBE M8X1,25X20U5739 8.8ZN	TORN. M8X1,25X20 U5739 8.8 ZN
6	F01410051R	ROS.M8 8,4X 17X1,6 U6592 ZN	WASHER M8 8,4X17X1,6 U6592 ZN	RONDELLE M8 8,4X17X1,6 ZN	SCHIEBE M8 8,4X17X1,6 U6592 ZN	ARANDELA M8 8,4X17X1,6 U6592ZN
7	F01260043R	DADO M8 D6923 8.8ZN	NUT M8 D6923 8.8ZN	ECROU BRIDE .M8 DIN 6923 8.8 Z	GEFLANSCHTE MUTTER M8 DIN6923	TUERCA BRIDA M8 DIN 6923 8.8 Z
8	G17922761R	LAMA SUPP.LINAK	LINAK SUPPORT			
9	F01230048R	DADO M10X1,5 D982 8ZN	NUT M10X1,5 D982 8ZN	ECR.AUTO-FREIN.M10X1,5 D982 ZN	SICHERUNGSMUTT.M10X1,5 D982 ZN	TUERCA SEGURID.M10X1,5 D982 ZN
10	F01020483R	VITE M10X1,5X40 U5739 10.9ZD	SCR. M10X1,5X40 U5739 10.9ZD	VIS M10X1,5X40 U5739 10.9 ZD	SCHRA.M10X1,5X40 U5739 10.9 ZD	TORN. M10X1,5X40 U5739 10.9 ZD
11	F01040064R	VITE M6X1X25 U5931 8.8ZN	SCREW M6X1X25 U5931 8.8ZN	VIS M6X1X25 U5931 8.8ZN	SCHRAUBE M6X1X25 U5931 8.8ZN	TORNILLO M6X1X25 U5931 8.8ZN
12	G18901771R	MOLLA TRAZ.RUOTA DP IX	TRACTION WHEEL SPRING DP IX			
13	F01200233R	DADO M6X1 U5588 A2IX	NUT M6X1 U5588 A2IX	ECROU M 6X 1 U5588 I	MUTTER M 6X 1 U5588	TUERCA M 6X 1 U5588
14	G17922270R	PORTELLINO PROVA SEMINA IX	TEST SEEDING IX HANDHOLE			
15	F02100111R	SPINA E.P. 6X 24 U6873 A2 IX	PIN EL. 6 X24 U6873 A2 IX			
16	F01020381R	VITE M5X0,8X20 U5739 A2IX	SCR. M5X0,8X20 U5739 A2IX	VIS 5X20 5739	SCHRAUBE 5X20 5739	TORNILLO 5X20 5739
17	F01230020R	DADO M5X0,8 D982 A2IX	NUT M5X0,8 D982 A2IX	ECROU M5X0,8 D982 A2 IX	MUTTER M5X0,8 D982 A2 IX	TUERCA M5X0,8 D982 A2 IX
18	F05011172R	MOTORID.12V-157W 50 1 C.CONN.	RATIOMOTOR 12V-157W 50 1			
19	G20970140R	RONDELLA 20X2X8,5	WASHER 20X2X8,5	RONDELLE 20X2X8,5	UNTERLEGSCHIEBE 20X2X8,5	ARANDELA 20X2X8,5
20	F01020445R	VITE M8X1,25X30 U5739 8.8ZN	SCR. M8X1,25X30 U5739 8.8ZN	VIS M 8X1,25X30 U5739 8.8 ZN	SCHRAU, M8X1,25X30 U5739 8.8ZN	TORN. M8X1,25X30 U5739 8.8 ZN
21	G16035710R	ALBERO TRASM.MOTORE ELETTRICO	ELECTRIC ENGINE TRANSM.SHAFT			
22	F02200452R	SPINA SCATTO D.4,4 B 80 ZN	SNAP PIN D4.4 B 80 ZN	FICHE A DETENTE D4.4 B 80 ZN	EINRASTSTIFT D4.4 B 80 ZN	CLAVIJA DE MUELLE D4,4 B 80 ZN
23	F01410088R	ROS.M14 15X 28X2,5 U6592 ZN	WAS.M14 15X 28X2,5 U6592 ZB	RON.M14 15X 28X2,5 U6592 ZB	SCH.M14 15X 28X2,5 U6592 ZB	ARA.M14 15X 28X2,5 U6592 ZB
24	F02100115R	SPINA E.P. 6X 30 U6873 C70 IX	PIN EL. 6X30 DIN 1481 S.STEEL*	GOUPILLE EL.6 X30 DIN 1481 IN	SPANNSTIFT 6 X30 DIN 1481 EDEL	CLAVIJA EL.6 X30 DIN 1481 INO
25	G16130860R	BOCCOLA UNIONE CAMBIO-DOS.STA.	GEAR JUNCTION BUSHING			
26	F02200595R	SPINA SICUR.D. 5X30 ZN	PIN X GEAR	GOUJON	BOLZEN	ESPINA
27	F01420048R	ROS.M8 8,4X 24X 2 U6593 ZN	WASHER M8 8,4X 24X2 U6593 ZN	RONDELLE M8 8,4X24X 2 U6593 ZN	SCHEIBEN M8 8,4X24X 2 U6593 ZN	ARANDELA M8 8,4X 24X2 U6593 ZN
28	F01020432R	VITE M8X1,25X16 U5739 8.8ZN	SCR. M8X1,25X16 U5739 8.8ZN	VIS M8 X1,25X16 U5739 8.8 ZN	SCHRAUBE M8X1,25X16U5739 8.8ZN	TORNILLO M8X1,25X16U5739 8.8ZN
29	F05200665R	CABL.COLLEGAMENTO LINAK	CABLE CONNECTION LINAK			
30	F05010020R	GUAINA CORRUGATA D.17 NERA	ROUGH SHEATH D.17 BLACK			
31	F02150012R	LINGUETTA 05X5X10 UNI6604	PARALLEL KEY 5X 5X 10 U6604A			
32	F05010545R	MOTORIDUTTORE 12V-157W 50 1	REDUCTION 12V-157W 50 1			
33	F01230034R	DADO M8X1,25 D982 8ZN	NUT M8X1,25 D982 8ZN	ECROU M8X 1,25 ZN	MUTTER M8X 1,25 D982 8 ZN	TUERCA M8X 1,25 D982 8 ZN

GENIUS MASTER

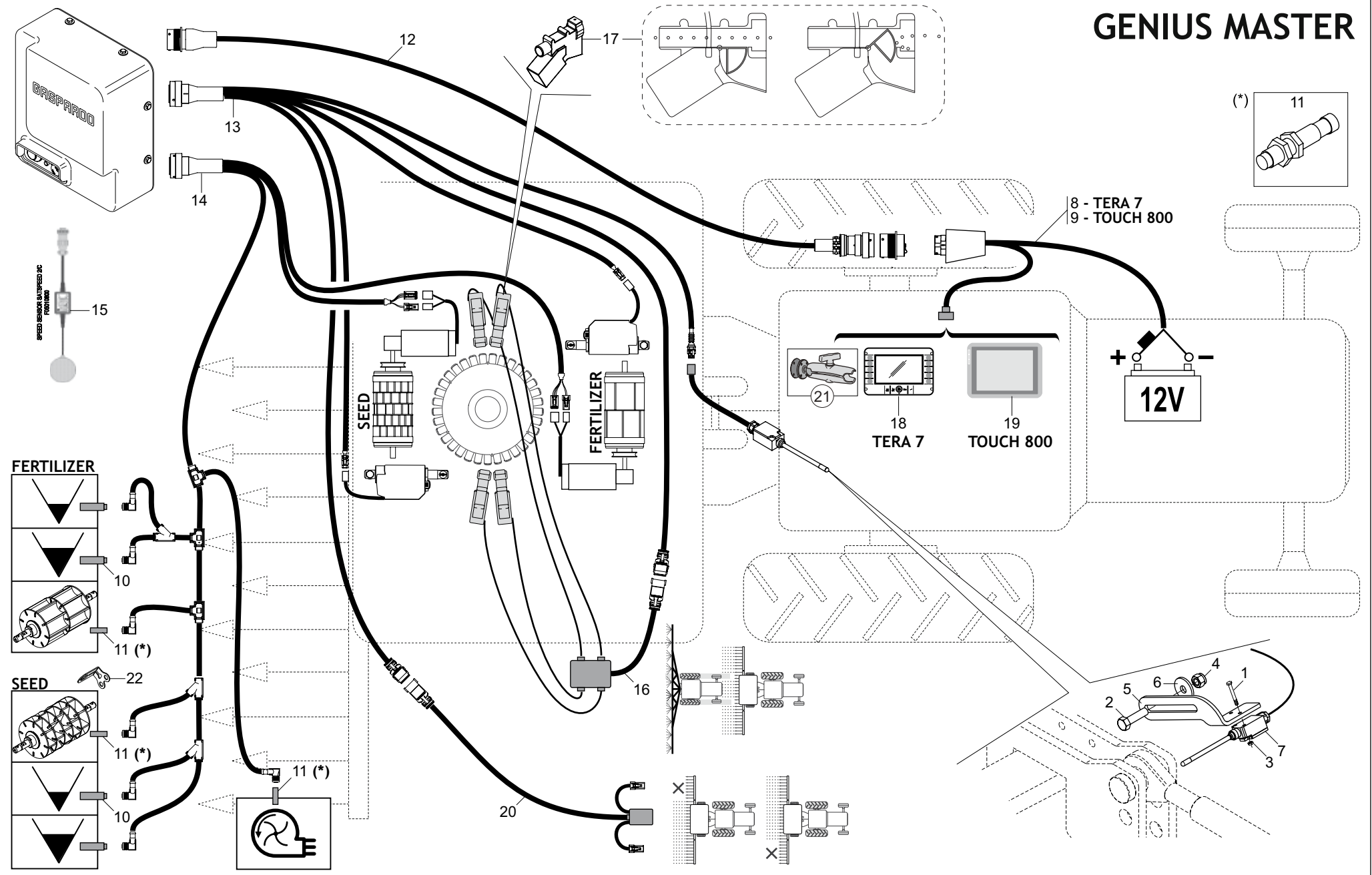

**GESTIONE ELETTRICA - «GENIUS MASTER»
EELECTRICAL SYSTEM - «GENIUS MASTER»**

TAV. 120

Pos.	Cod.	Descrizione	Description	Description	Benennung	Descripcion
1	F01020024R	VITE M5X0,8X40 U5737 8.8ZN	SCR. M5X0,8X40 U5737 8.8ZN	VIS 5X40 5737 8.G ZN	SCHRAUBE 5X40 5737 8.G ZN	TORNILLO 5X40 5737 8.G ZN
2	F01020152R	VITE M12X1,75X40 U5737 8.8ZN	SCR. M12X1,75X40 U5737 8.8ZN	VIS M12X1,75X40 U5737 8.8 ZN	SCHRAUBE M12X1,75X40U57378.8ZN	TORNIL.M12X1,75X40 U5737 8.8ZN
3	F01200220R	DADO M5X0,8 U5588 CL8 ZN	NUT M5X0,8 U5588 6.8ZN	ECROU 5 UNI 5588 6.8 ZN	MUTTER 5 UNI 5588 6.8 ZN	TUERCA 5 UNI 5588 6.8 ZN
4	F01230059R	DADO M12X1,75 D982 8ZN	LOCK-NUT M12X1,75 D982 8ZN	ECR.AUTO-FREI.M12X1,75 ZN	SICHERUNGSMUT.M12X1,75 D982 8ZN	TUER.DE SEGUR.M12X1,75 D982 ZN
5	GA7912420R	LAMA SUPPORTO FINGER ZN	BLADE SUPPORT FINGER ZN			
6	G20970085R	RONDELLA 40X4X13	WASHER 40X4X13	RONDELLE 40X4X13	UNTERLEGSSCHEIBE 40X4X13	ARANDELA 40X4X13
7	F05010157R	SENSORE FINGER CON CAVO L=1300	SENSOR FINGER WITH CABLE L=130			
8	F05200546R	CABLAGGIO MONITOR GM 7	CABLE MONITOR GM 7			
9	F05010742R	CABLAGGIO MONITOR MULLER	CABLE MONITOR MULLER			
10	F05010891R	SENSORE CAP.M18X1 NPN-NO C M12	CAPAC.SENS.M18X1 NPN-NO C M12			
11	F05010396R	SENSORE IND.M12X1 NPN-NO 4 MM	SENSOR IND. NBN4-12GM50-EO-V1			
12	F05200010R	CABLAGGIO ISOBUS F-F 5 METRI	F-F ISOBUS CABLE 5 METERS			
13	F05200668R	CABL.SENSORI PINTA 600 GM	CABLE SENSOR PINTA 600 GM			
14	F05200667R	CABL.ALIM.MOTORI PINTA600 GM	CABLE POWER ENG.PINTA600 GM			
15	F05010800R	SENSORE VELOCITA SATSPEED 2 C	SPEED SENSOR SATSPEED 2 C			
16	F05011772R	SCATOLA DERIVAZIONE TRAMLINE	SHUNT BOX TRAMLINE			
17	F05010486R	DISP.EL.ESCL.FILE WUK-97S V3	EL.DEVICE DISEN.ROW WUK-97S V3		DISP.EL.ESCL.FILE WUK-97S V3	
18	F05011637R	MONITOR ASSY TERA 7 UT C USB	MONITOR ASSY TERA 7 UT W USB			
19	F05011783R	MONITOR TOUCH 800 ISOBUS	MONITOR TOUCH 800 ISOBUS.			
20	F05011771R	SCATOLA DERIVAZIONE LINAK	SHUNT BOX LINAK			
21	F05011600R	KIT STAFFA RAM BASE TERA 7	KIT BRACKET RAM BASE TERA 7			
22	G16050340R	STAFFA LETTURA SENSORE ZN	BRACKET READ SENSOR ZN			

GENIUS MASTER

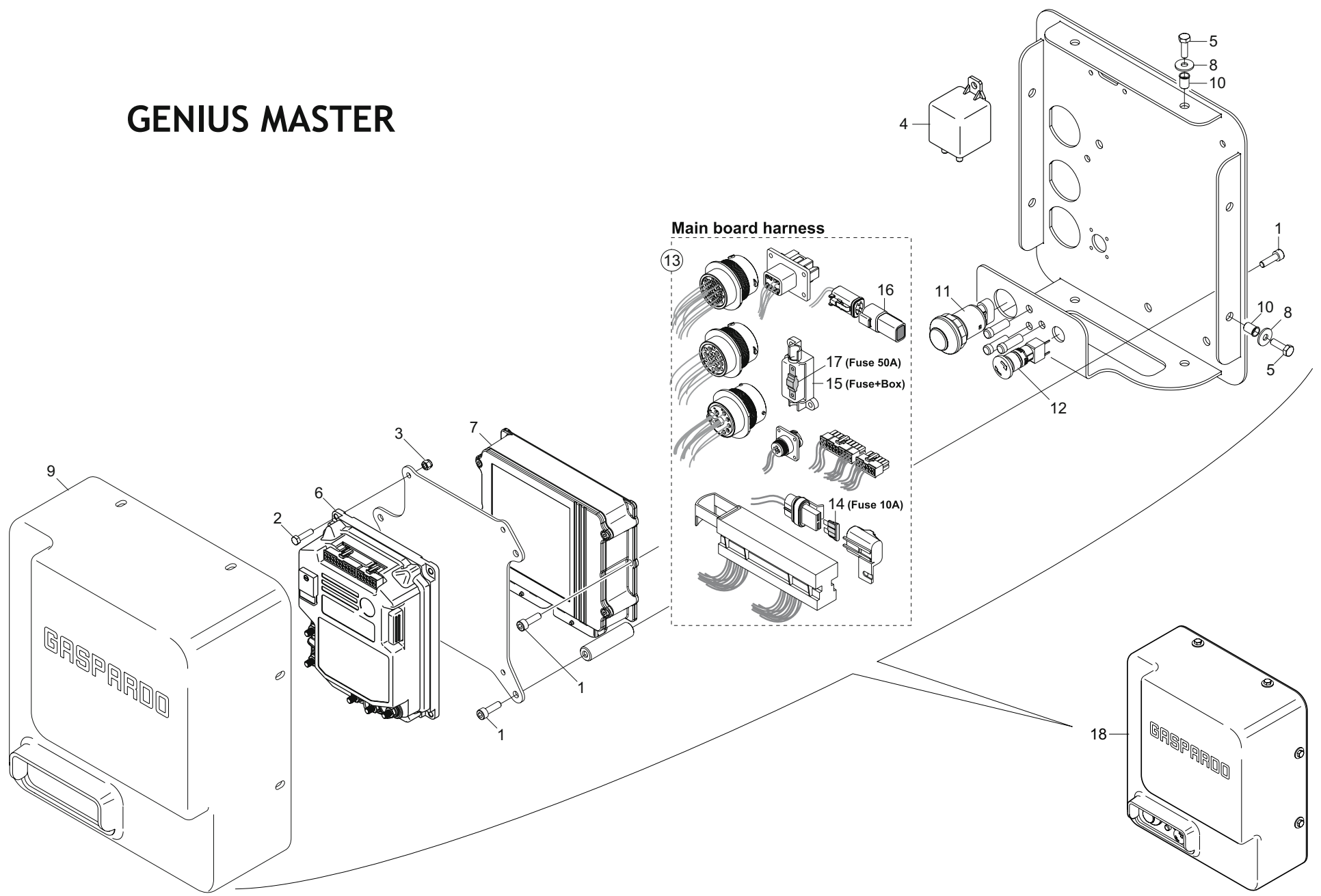

**SCATOLA COMANDO ELETTRICO - «GENIUS MASTER»
ELECTRICAL CONTROL BOX - «GENIUS MASTER»**

TAV. 320

Pos.	Cod.	Descrizione	Description	Description	Benennung	Descripcion
1	F01040063R	VITE M6X1X20 U5931 8.8ZN	SCR. M6X1X20 U5931 8.8ZN	VIS M 6	SCHRAUBE M 6	TORNILLO M 6
2	F01020381R	VITE M5X0,8X20 U5739 A2IX	SCR. M5X0,8X20 U5739 A2IX	VIS 5X20 5739	SCHRAUBE 5X20 5739	TORNILLO 5X20 5739
3	F01230020R	DADO M5X0,8 D982 A2IX	NUT M5X0,8 D982 A2IX	ECROU M5X0,8 D982 A2 IX	MUTTER M5X0,8 D982 A2 IX	TUERCA M5X0,8 D982 A2 IX
4	F05010573R	RELE 12V-200A CON STAFFA	RELAY 12V-200A WITH BRACKET			
5	F01020420R	VITE M6X1X20 U5739 A2IX	SCR. M6X1X20 U5739 A2IX	VIS M6 X1 X 20 U5739 8.8 IX	SCHRAUBE M6X1X20 U5739 A2 IX	TORNIL. M6 X1 X 20 U5739 8.8
6	F05011513R	CHOPPER CAN DUAL	CHOPPER CAN DUAL			
7	F05011611R	ECU ASSY MG 56 GM CEREALE	ECU ASSY MG 56 GM CEREAL			
8	F01420038R	ROS.M6 6,4X18X1,5 U6593 IX	WASHER M6 6,4X18X1,5 U6593 IX	RONDELLE M6 6,4X18X1,5U6593 IX	SCHEIBE M6 6,4X18X1,5 U6593 IX	ARANDELA M6 6,4X18X1,5 6593IX
9	G19007710R	COVER BOX GM CEREALE 2016	COVER BOX GM CEREAL 2016			
10	F02250680R	INSERTO FIL.M 6X13 ZN T.RIDOTT	THREADED INSERT M6X13 ZN	PIECE INTERC.FILETEE M 6X13ZN	GEWINDEEINSATZ M 6 X 13 ZN	ENCASTRE ROSCADO M 6 X13 ZN
11	F05011782R	PULSANTE CALIBRAZIONE	CALIBRATION SWITCH			
12	F05011750R	PULSANTE EMERGENZA	EMERGENCY SWITCH			
13	F05200684R	CABL.BOX EL.GM CEREALE 2016	CABLE ELECTR.BOX CEREAL 2016			
14	F05011415R	FUSIBILE 10AATO	FUSE 10AATO			
15	F05011808R	FUSIBILE HOLDER MTA 50A MIDI	FUSE HOLDER MTA 50A MIDI			
16	F05010906R	RESISTENZA 120 OHM - 1 4 W	RESISTANCE 120 OHM			
17	F05011357R	FUSIBILE MTA 50A MIDI	FUSE MTA 50A MIDI			
18	G16131400R	BOX ELETTRICO CEREALE 16	ELECTRIC BOX CEREAL 16			

mod.
48 file/rows

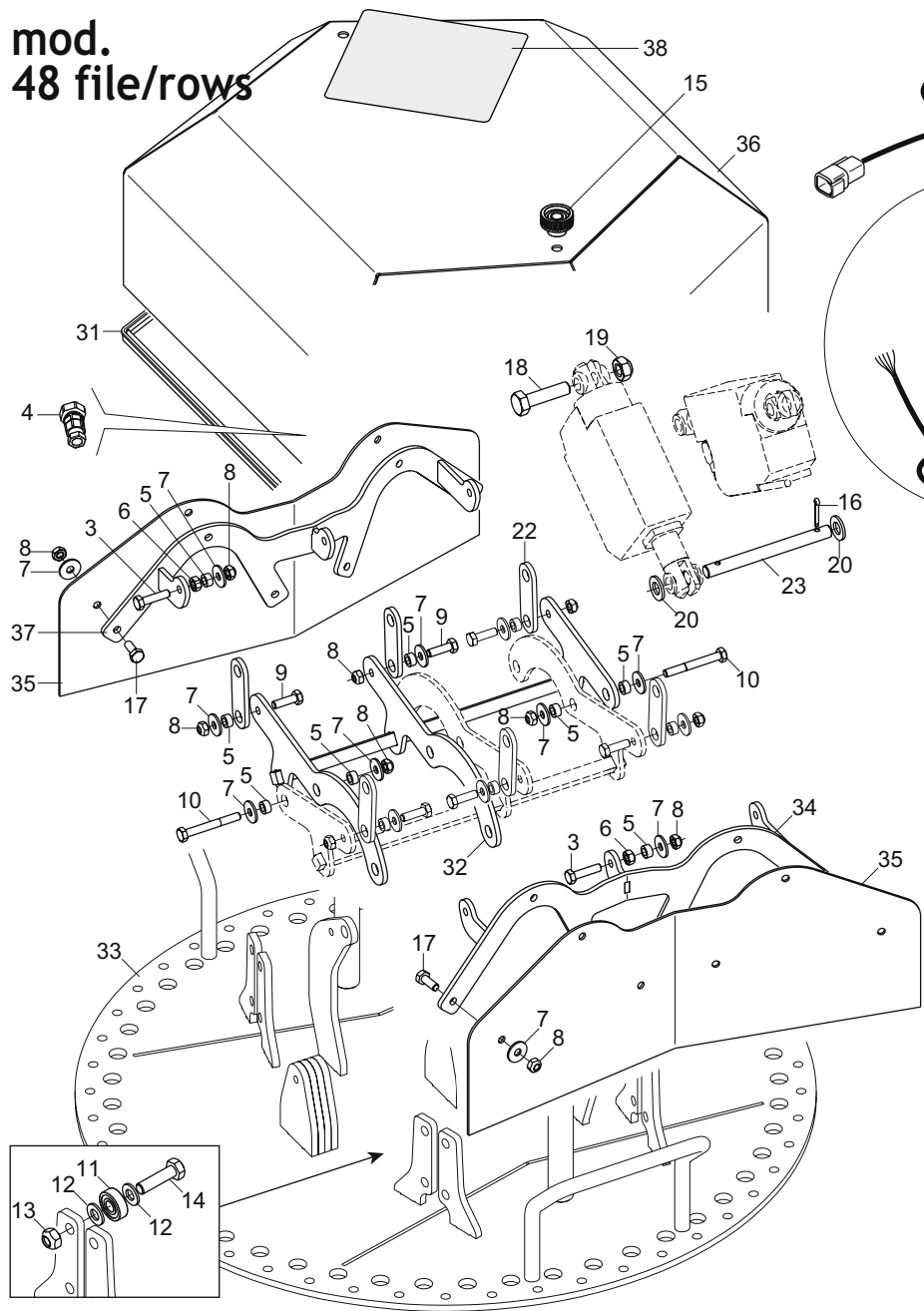

mod.
40 file/rows

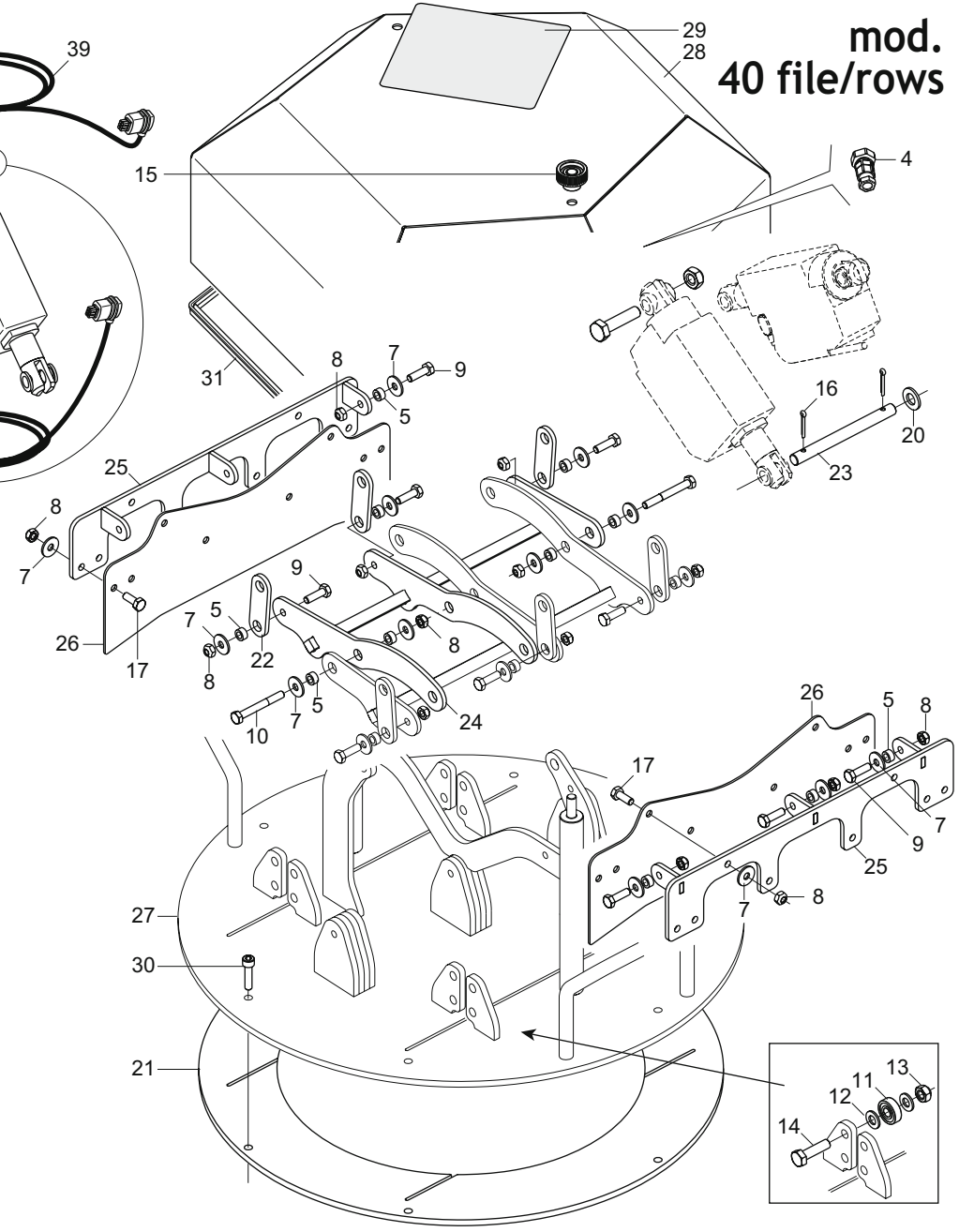

**PARZIALIZZATORE SEMINA
SEEDING PARTIALIZER**

TAV. 141

Pos.	Cod.	Descrizione	Description	Description	Benennung	Description
1	F05010665R	CAVO COLL.ATT. LINAK LA23	CON.TION ATT. CABLE LINAK LA23			
2	F05010738R	KIT ATTUAT. LINAK LA23 C.20MM	KIT ACTUAT.LINAK LA23 C.20MM			
3	F01020406R	VITE M6X1X25 U5739 8.8ZN	SCR. M6X1X25 U5739 8.8ZN	VIS M 6X25	SCHRAUBE M 6X25	TORNILLO M 6X25
4	F05010084R	PRESSACAVO PG.7 GEWISS	CABLE PRESS PG.7 GEWISS			
5	G18802180R	BOCCOLA 6,25X10X5 ZN	BUSHING 6,25X10X5 ZN			
6	F01200232R	DADO M6X1 U5588 CL8 ZN	NUT M6X1 U5588 6.8ZN	ECROU 6 UNI 5588 6.8 ZN	MUTTER 6 UNI 5588 6.8 ZN	TUERCA 6 UNI 5588 6.8 ZN
7	F01420036R	ROS.M6 6,4X 18X1,5 U6593 ZN	WASHER M6 6,4X 18X1,5 U6593 ZN	RONDELLE M6 6,4X18X1,5 U6593ZN	SCHEIBEN M6 6,4X18X1,5U6593 ZN	ARANDELA M6 6,4X18X1,5U6593ZN
8	F01220011R	DADO M6X1 D980 8ZN	NUT M6X1 D980 8ZN	ECROU M6X1 D980 8 ZN	MUTTER M6X1 D980 8 ZN	TUERCA M6X1 D980 8 ZN
9	F01020404R	VITE M6X1X20 U5739 8.8ZN	SCREW M6X1X20 U5739 8.8ZN	VIS M6X1X20 U5739 8.8ZN	SCHRAUBE M6X1X20 U5739 8.8ZN	TORNILLO M6X1X20 U5739 8.8ZN
10	F01020042R	VITE M6X1X50 U5737 8.8ZN	SCR. M6X1X50 U5737 8.8ZN	VIS M6X1X50 U5737 8.8ZN	SCHRAU. M6X1X50 U5737 8.8ZN	TORNI. M6X1X50 U5737 8.8ZN
11	F04010113R	CUSC.D8 D22 B7 608 2RS IX	BEARING D8 D22 B7 608 2RS IX			
12	F01410051R	ROS.M8 8,4X 17X1,6 U6592 ZN	WASHER M8 8,4X17X1,6 U6592 ZN	RONDELLE M8 8,4X17X1,6 ZN	SCHEIBE M8 8,4X17X1,6 U6592 ZN	ARANDELA M8 8,4X17X1,6 U6592ZN
13	F01220022R	DADO M8X1,25 D980 8ZN	NUT M8X1,25 D980 8ZN	ECROU M8X 1,25 D980 8 ZN	MUTTER M8X 1,25 D980 8 ZN	TUERCA M8X 1,25 D980 8 ZN
14	F01020445R	VITE M8X1,25X30 U5739 8.8ZN	SCR. M8X1,25X30 U5739 8.8ZN	VIS M 8X1,25X30 U5739 8.8 ZN	SCHRAU. M8X1,25X30 U5739 8.8ZN	TORN. M8X1,25X30 U5739 8.8 ZN
15	F06220037R	VOLANTINO ZIGR.D.26-M8 FEM	KNURLED HANDWHEEL D.26-M8			
16	F02200162R	COPIGLIA 3X 20 U1336 ZN	SPLIT PIN 3 X20 1336 GALVAN.	GOUPILLE 3 X20 1336 ZN	SPLINT 3 X20 1336 ZN	PASADOR 3 X20 1336 ZN
17	F01020403R	VITE M6X1X16 U5739 8.8ZN	SCR. M6X1X16 U5739 8.8ZN	VIS M6X1X16 U5739 8.8 ZN	SCHRAUBE M6X1X16 U5739 8.8 ZN	TORNILLO M6X1X16 U5739 8.8 ZN
18	F01020483R	VITE M10X1,5X40 U5739 10.9ZD	SCR. M10X1,5X40 U5739 10.9ZD	VIS M10X1,5X40 U5739 10.9 ZD	SCHRA.M10X1,5X40 U5739 10.9 ZD	TORN. M10X1,5X40 U5739 10.9 ZD
19	F01220033R	DADO M10X1,5 D980 8ZN	NUT M10X1,5 D980 8ZN	ECROU M10X1,5 D980 8ZN	MUTTER M10X1,5 D980 8ZN	TUERCA M10X1,5 D980 8ZN
20	F01410064R	ROS.M10 10,5X 20X 2 U6592 ZN	WASHER M10 10,5X20X2 U6592 ZN	RONDEL. M10 10,5X20X2 U6592 ZN	SCHEIBE M10 10,5X20X2 U6592 ZN	ARANDEL.M10 10,5X20X2 U6592 ZN
21	G16026620R	DISTANZIALE COP. PARZ. 12 12	SPACER 12 12			
22	G16025550R	SCONTRO 20X 63- 4 2F10	CLASH 20X 63- 4 2F10			
23	G16026340R	TONDO D10 L113	ROUND D10 L113			
24	G16026640R	ASS.SUPP.MOV.PARZIALIZZATORE	ASS.SUPPORT			
25	G16026670R	ASS.SUPP.PARATIA	ASS.SUPPORT BULKHEAD			
26	G16026700R	PARATIA 12 PER FUNGO 40	BULKHEAD 12 FOR MUSHROOM 40			
27	G16026710R	ASS.COPERCHIO	ASS.COVER			
28	G16026780R	ASS.COPERCHIO ESAGONALE	ASS.EXAGONAL COVER			
29	G19709620R	DECAL PARZIALIZ.12 12 SEM.CONC	DECAL PARZ.12 12 SEM.FERT			
30	F01040064R	VITE M6X1X25 U5931 8.8ZN	SCREW M6X1X25 U5931 8.8ZN	VIS M6X1X25 U5931 8.8ZN	SCHRAUBE M6X1X25 U5931 8.8ZN	TORNILLO M6X1X25 U5931 8.8ZN
31	F03011137R	GUARNIZIONE P.1464	GASKET P.1464			
32	G16026140R	ASS.SUPP.MOV.PARZIALIZZATORE	ASS.SUPPORT			
33	G16026180R	ASS.COPERCHIO	ASS.COVER			
34	G16026220R	ASS.SUPP.PARATIA SX	ASS.SUPPORT BULKHEAD LEFT			
35	G16026250R	PARATIA 14 PER FUNGO 48	BULKHEAD 14 FOR MUSHROOM 48			
36	G16026350R	ASS.COPERCHIO ESAGONALE	ASS.EXAGONAL COVER			
37	G16026400R	ASS.SUPP.PARATIA DX	ASS.SUPPORT BULKHEAD RIGHT			
38	G19709350R	DECAL.PARZIALIZ.14 14SEME-CONC	DECAL PARZ.14 14SEED-FERT.			
39	F05200665R	CABL.COLLEGAMENTO LINAK	CABLE CONNECTION LINAK			

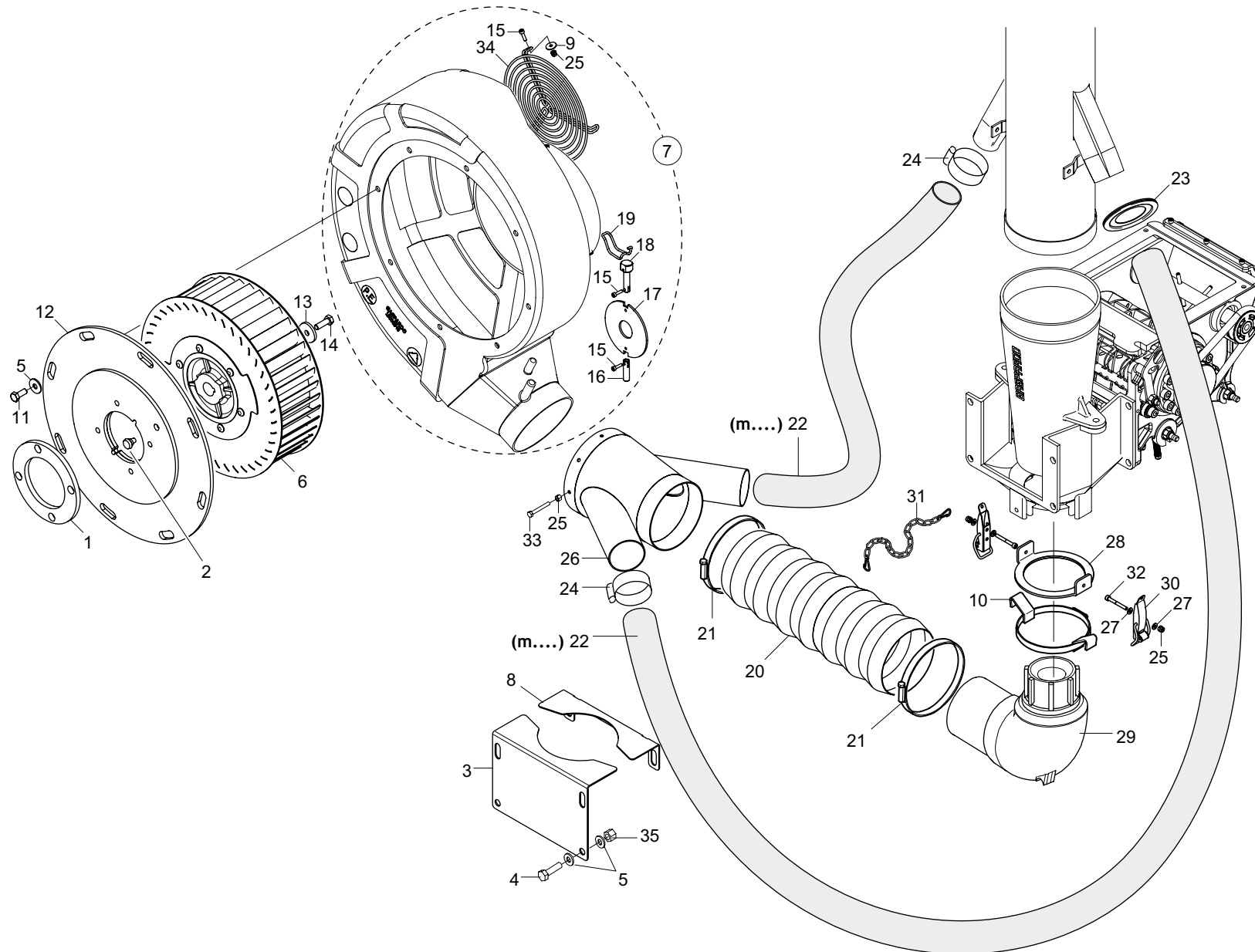

SOFFIANTE BLOWER

TAV. 150

Pos.	Cod.	Descrizione	Description	Description	Benennung	Descripcion
1	G16050470R	FLANGIA D.135 4 FORI D.13	FLANGE D.135 4 HOLES D.13	BRIDE D.135 4 DE TROUS D.13	FLANSCH D.135 4 LOCHER D.13	BRIDA D.135 4 AGUJEROS D.13
2	G66248223R	TAPPO SUPP.SPAND.D.11	PLUG MAN. SPR. SUPP. D.11	BOUCHON SUPPORT EP. ENGRAIS D.	HALTERUNGSPFROPFEN DSNGERSTR.	TAP N SOPORTE ABON.D.11
3	G16023210R	CHIUSURA ANTERIORE	FRONT LOCKING			
4	F01020440R	VITE M8X1,25X25 U5739 8.8ZN	SCR. M8X1,25X25 U5739 8.8ZN	VIS M8X1,25X25 U5739 8.8 ZN	SCHRAUBE M8X1,25X25U5739 8.8ZN	TORNIL.M8X1,25X25 U5739 8.8 ZN
5	F01420048R	ROS.M8 8,4X 24X 2 U6593 ZN	WASHER M8 8,4X 24X2 U6593 ZN	RONDELLE M8 8,4X24X 2 U6593 ZN	SCHEIBEN M8 8,4X24X 2 U6593 ZN	ARANDELA M8 8,4X 24X2 U6593 ZN
6	G68190002R	GIRANTE D300 - 42 PALE	FAN WHEEL D300 - 42			
7	F06210002R	VOLUTA COMPL.SENZA GIRANTE	VOLUTE WITHOUT FAN ASS.BLY			
8	G16023220R	CHIUSURA SUPERIORE	FRONT LOCKING			
9	F01420011R	ROS.M4 4,3X 16X 1 U6593 ZN	FLAT WASHER 4-3X 16X1-5 6593 G	ROND.Plate 4-3X 16X1-5 6593 ZN	SCHEIBE 4-3X 16X1-5 6593 ZN	ARAND. PLANA 4-3X 16X1-5 6593
10	G16021020R	GANCIO CHIUSURA A LEVA	LEVER-CLOSED HOOK	CROCHET FERMETURE A LEVIER	HEBELSCHLISSHAKEN	GANCHO CIERRE DE PALANCA
11	F01020436R	VITE M8X1,25X20 U5739 8.8ZN	SCR. M8X1,25X20 U5739 8.8ZN	VIS M8X1,25X 20 U5739 8.8 ZN	SCHRAUBE M8X1,25X20U5739 8.8ZN	TORN. M8X1,25X20 U5739 8.8 ZN
12	G16050730R	SUPPORTO VOLUTA	BLOWER SUPPORT			
13	G20970032R	RONDELLA 32X4X8,5	WASHER 32X4X8-5	RONDELLE 32X4X8-5	UNTERLEGSCHIEBE 32X4X8-5	ARANDELA 32X4X8-5
14	F01020445R	VITE M8X1,25X30 U5739 8.8ZN	SCR. M8X1,25X30 U5739 8.8ZN	VIS M 8X1,25X30 U5739 8.8 ZN	SCHRAU, M8X1,25X30 U5739 8.8ZN	TORN. M8X1,25X30 U5739 8.8 ZN
15	F01040028R	VITE M4X0,7X16 U5931 8.8ZN	SCREW M4X0,7X16 U5931 8.8ZN	VIS M4X0,7X16 U5931 8.8ZN	SCHRAUBE M4X0,7X16 U5931 8.8ZN	TORNILLO M4X0,7X16 U5931 8.8ZN
16	G68190009R	PERNO INFERIORE ZN	LOWER PIN			
17	G68190010R	SPORTELLO REGOLAZIONE ARIA ZN	AIR REGULATION DOOR			
18	G68190008R	PERNO SUPERIORE ZN	UPPER PIN			
19	G68190006R	MOLLA DI SICUREZZA	SAFETY SPRING			
20	F03100427R	TUBO FLESSIBILE D.100	FLEXIBLE PIPE D.100	TUBE FLEXIBLE D.100	SCHLAUCH D.100	TUBO FLEXIBLE D.100
21	F02300025R	FASCETTA STRING. 90 110 H.12	HOSE CLAMP 90 110 H.12			
22	F03100493R	TUBO EOLO PU 52	EOLO PIPE 50	TUBE EOLO 50	ROHR EOLO 50	TUBO EOLO 50
23	G19007180R	GUARNIZIONE D.70 MM	GASKET D.70 MM			
24	F02300021R	FASCETTA STRING. 40 60 H.8	STRING FASTEN.STRAPS 40 60 H.8	COLLIER DE SERRAGE 40 60 H.8	SCHELLE 40 60 H.8	ABRAZADERA 40 60 H.8
25	F01230016R	DADO M4X0,7 D982 8ZN	NUT M4X0,7 D982 8ZN	ECROU AUTOB.NOR.4 ZN	SELBSTSP. MUTTER NOR. 4 ZN	TUERCA AUTOB. NOR. 4 ZN
26	G16050680R	CONO BY-PASS	BY-PASS CONE			
27	F01410011R	ROS.M4 4,3X 9X0,8 U6592 ZN	PLANE WASHER 4,5X 9 6592	RONDELLE 4,5X 9 6592	SCHEIBE 4,5X 9 6592	ARANDELA 4,5X 9 6592
28	G16024850R	GUIDA CURVA	CURVE GUIDE			
29	G68005079R	CURVA 145X147,5	145X147,5 BEND	COUDE D AIR 145X147,5	KNIESTSCK 145X147,5	CURVA 145X147,5
30	G16021040R	LEVA CHIUSURA	CLOSURE LEVER	LEVIER DE FERMETURE	ABSCHLUSSHEBEL	PALANCA DE CIERRE
31	G13812311R	CATENELLA CON MOSCHETTONE	CHAIN WITH SPRING CATCH	CHAINETTE AVEC MOUSQUETON	KETTE MIT KARABINERHAKEN	CADENA CON GANCHO
32	F01040030R	VITE M4X0,7X35 U5931 12.9ZF	SCR. M4X0,7X35 U5931 12.9ZF	VIS M4X0,7X35 U5931 12.9ZF	SCHRAU. M4X0,7X35 U5931 12.9ZF	TORNIL. M4X0,7X35 U5931 12.9ZF
33	F01020363R	VITE M4X0,7X16 U5739 8.8ZN	SCR. M4X0,7X16 U5739 8.8ZN	VIS M4X 0,7X16 U5739 8.8 ZN	SCHRA. M4X 0,7X16 U5739 8.8 ZN	TORN. M4X 0,7X16 U5739 8.8 ZN
34	G68190007R	GRIGLIA DI PROTEZIONE	PROTECTION GRID STOP			
35	F01230034R	DADO M8X1,25 D982 8ZN	NUT M8X1,25 D982 8ZN	ECROU M8X 1,25 ZN	MUTTER M8X 1,25 D982 8 ZN	TUERCA M8X 1,25 D982 8 ZN

TAV. 160

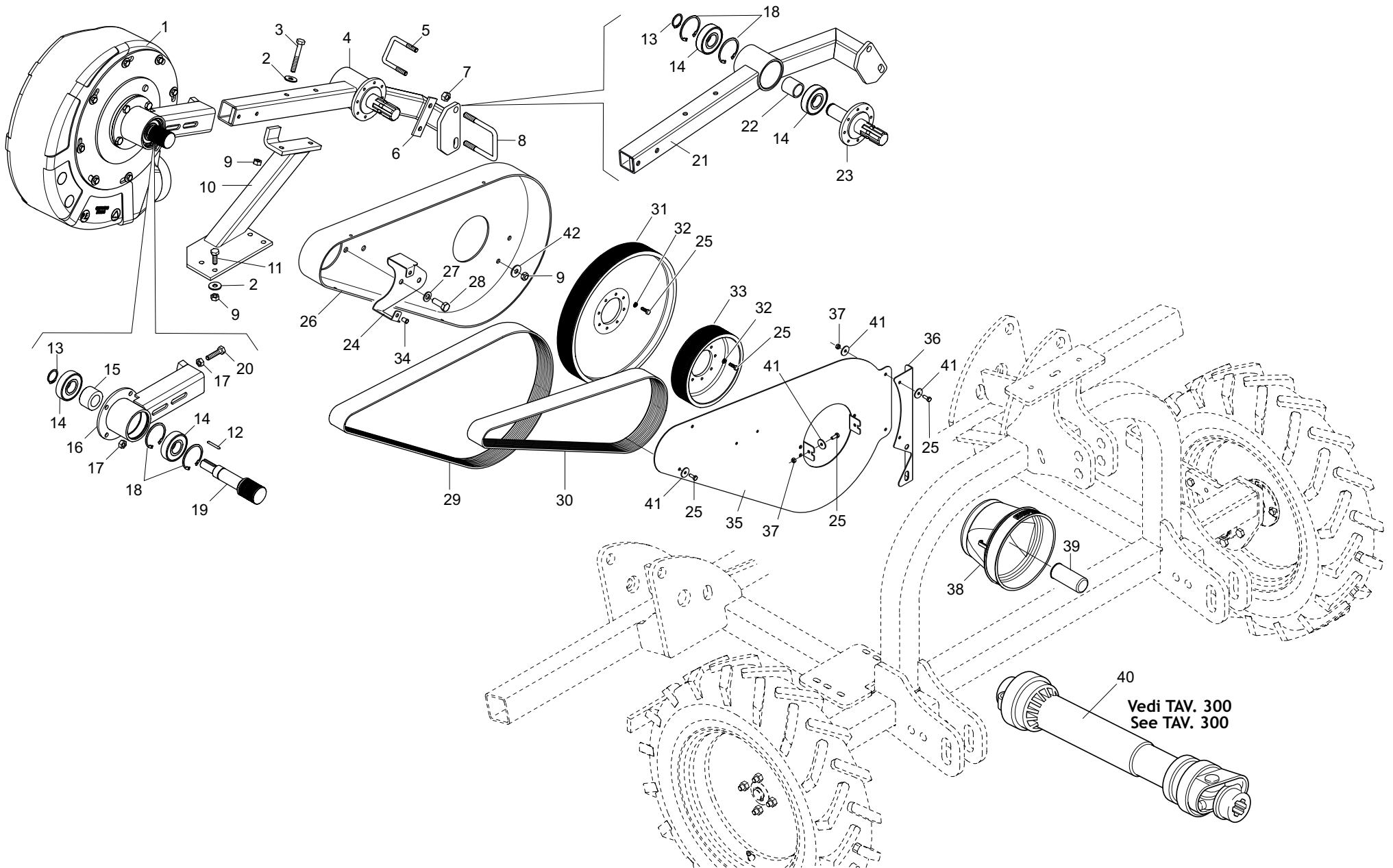

AZIONAMENTO MECCANICO SOFFIANTE FAN MECHANICAL DRIVE

TAV. 160

Pos.	Cod.	Descrizione	Description	Description	Benennung	Descripcion
1	G16050791R	VENT.PINTA D.290-90-42 COMPL.	COMPLETE FAN PINTA D.290-90-42			
2	F01420060R	ROS.M10 10,5X 30X2,5 U6593 ZG	GALV.WASHER 10,5X30X2,5 U6593	RONDELLE 10,5X30	SCHEIBE 10,5X30	ARANDELA 10,5X30
3	F01020125R	VITE M10X1,5X75 U5737 8.8ZN	SCR. M10X1,5X75 U5737 8.8ZN	VIS M10X1,5X75 U5737 8.8ZN	SCHRAU. M10X1,5X78 U5737 8.8ZN	TORN. M10X1,5X75 U5737 8.8ZN
4	G16032841R	SUPP.ASSE P.D.F.COMPL	POWERTAKEOFF AXLE SUPPORT			
5	F20110715R	CAV.Q.B=50 M=10X1,5 L=80	UBOLTSTRIKER Q.B=50M10X1,5L=80	BUTEE M10X 1,5X 30 61X 80 ZB	ANSCHLAG M10X 1,5X 30 61X 80	EL. DE EMPALME M10X 1,5X 30
6	G16015690R	SCONTR0 100X30 -5 2F11 62	PLATE 100X30 -5 2F11 62			
7	F01220048R	DADO M12X1,75 D980 8ZN	NUT M12X1,75 D980 8ZN	ECROU M12X1,75 D980 8 ZN	SCHEIBE M12X1,75 D980 8 ZN	TUERCA M12X1,75 D980 8 ZN
8	F20110745R	CAV.Q.B=70 M=12X1,75L=96	U BOLT Q.B=70 M=12X1,75 L=96	CAVALIER M12 POUR TUBE 70X70	BSGELBOLZEN M12 FSR ROHR 70X70	PERNO EN U M12 X TUBO 70X70
9	F01220033R	DADO M10X1,5 D980 8ZN	NUT M10X1,5 D980 8ZN	ECROU M10X1,5 D980 8ZN	MUTTER M10X1,5 D980 8ZN	TUERCA M10X1,5 D980 8ZN
10	G16019100R	SUPPORTO GRUPPO ASSE P.D.P.	P.D.P. AXIS GROUP SUPPORT	SUPPORT GROUPE AXE P.D.P.	HALTERUNG ACHSENAGGREGAT P.D.P.	SOPORTE GRUPO EJES P.D.P.
11	F01020479R	VITE M10X1,5X35 U5739 8.8ZN	SCR. M10X1,5X35 U5739 8.8ZN	VIS M10X1,5X35 U5739 8.8 ZN	SCHR. M10X1,5X35 U5739 8.8 ZN	TORN. M10X1,5X35 U5739 8.8 ZN
12	F02150038R	LINGUETTA 6X 6X 30 U6604A	PARALLEL KEY 6X 6X 30 U6604A	LANGUETTE 06X6X30 UNI6604	FEDERKEIL 06X6X30 UNI6604	LENGSETA 06X6X30 UNI6604
13	F02050112R	ANELLO E.DE 30X 1,5 U7435 ZN	SEEGER RING 30X 1,5 U7435 C70	SEEGER E. 30 X 1,5 U7435 C70	SEEGERING E. 30X 1,5 U7435 C70	ANILLO E. 30 X 1,5 U7435 C70
14	F04010215R	CUSC.D30 D72 B19 6306 2RSC3 EX	BEARING D30 D72 B19 6306 2RSC3	ROULEMENT	LAGER 6306 2RS C3	COJINETE 6306 2RS C3
15	G18802060R	BOCCOLA 50X30,5X30	BUSHING 50X30,5X30	BOITE 50X30,5X30	BUCHSE 50X30,5X30	MANGUITO 50X30,5X30
16	G16015570R	SUPPORTO VENTOLA	FAN SUPPORT	SUPPORT ROTOR	HALTERUNG LAUFRAD	HALTERUNG LAUFRAD
17	F01200270R	DADO M10X1,5 U5588 CL8 ZN	NUT M10X1,5 U5588 6.8ZN	ECROU M10X 1,5 U5588 6.8 ZN	MUTTER M10X 1,5 U5588 6.8 ZN	TUERCA M10X 1,5 U5588 6.8 ZN
18	F02050403R	ANELLO E. DI 72X 2,5 U7437 C7	SEEGER RING E.72X2,5 U7437 C70	SEEGER E. 72X 2,5 U7437 C70	SEEGERING E. 72X 2,5 U7437 C70	ANILLO E. 72X 2,5 U7437 C70
19	G16032361R	ASSE VENTOLA D.40	SPREADER FAN	AXE ROTOR	ACHSE LAUFRAD	EJE VENTILADOR
20	F01020485R	VITE M10X1,5X50 U5739 8.8ZN	SCR. M10X1,5X50 U5739 8.8ZN	VIS M 10X50	SCHRAUBE M 10X50	TORNILLO M 10X50
21	G16018431R	ASS.SUPPORTO ASSE P.D.F.	ASSY PTO AXLE SUPPORT			
22	G22230010R	DISTANZIALE CUSCINETTI	BEARING SPACER	ENTRETOISE PALIERS	DISTANZSTSCK LAGER	DISTANCIADOR COJINETES
23	G22230011R	PRESA DI FORZA	POWER TAKE-OFF	PRISE DE FORCE	ABTRIEB	TOMA DE FUERZA
24	G16034870R	STAFFA SUPPORTO CARTER	CARTER SUPPORT BRACKET			
25	F01020403R	VITE M6X1X16 U5739 8.8ZN	SCR. M6X1X16 U5739 8.8ZN	VIS M6X1X16 U5739 8.8 ZN	SCHRAUBE M6X1X16 U5739 8.8 ZN	TORNILLO M6X1X16 U5739 8.8 ZN
26	G19003640R	CARTER POSTERIORE P-PI	REAR CASE P-PI	CARTER POSTERIEUR P-PI	GEHZUSE HINTERE P-PI	CARTER TRASERO P-PI
27	F01410076R	ROS.M12 13X 24X2,5 U6592 ZN	WASHER 12 13X 24X2,5 U6592 ZN	RONDEL. M12 13X24X2,5 U6592 ZN	SCHEIBE M12 13X24X2,5 U6592 ZN	ARANDELA M12 13 X24X2,5 ZN
28	F01020512R	VITE M12X1,75X35 U5739 8.8ZN	SCR. M12X1,75X35 U5739 8.8ZN	VIS M12X1,75X35 5739 8.8 ZN	SCHR. M12X1,75X35 5739 8.8 ZN	TORN. M12X1,75X35 5739 8.8 ZN
29	F06010163R	CINGHIA POLY V 1752 J-20 GOLE	BELT- POLY V 1753 J-20 GOLE	COURROIE POLY-V 1753 J-20 GOR	RIEMEN POLY V 1753 J-20 RILLEN	CORREA POLY V 1753 J-20 GARGAN
30	F06010164R	CINGHIA POLY V 1473 J-20 GOLE	BELT- POLY V 1475 J-20 GOLE	COURROIE POLY-V 1475 J-20 GOR	RIEMEN POLY V 1475 J-20 RILLEN	CORREA POLY V 1475 J-20 GARGAN
31	G16032350R	PULEGGIA MOTRICE 540 G.	DRIVING PULLEY 540 REVS	POULIE MOTRICE 540 TOURS	ANTRIEBSSCHEIBE 540 UMDREHUNG	POLEA MOTRIZ 540 REVOLUCIONES
32	F01460104R	ROS.OND. 6,4X 11X0,5 ZB D137A	WASHER D6 DIN 137 A ZN	RONDELLE D6 DIN 137 A ZN	UNTERLEGSCHIEBE D6 DIN 137 A Z	ARANDELA D6 DIN 137 A ZN
33	G16032340R	PULEGGIA MOTRICE 1000 GIRI	DRIVING PULLEY 1000 REVS	POULIE MOTRICE 1000 TOURS	ANTRIEBSSCHEIBE 1000 UMDREHUNG	POLEA MOTRIZ 1000 REVOLUCIONES
34	F02250680R	INSERTO FIL.M 6X13 ZN T.RIDOTT	THREADED INSERT M6X13 ZN	PIECE INTERC.FILETEE M 6X13ZN	GEWINDEEINSATZ M 6 X 13 ZN	ENCASTRE ROSCADO M 6 X13 ZN
35	G16034940R	ASS.CARTER FRONT.PROT.CINGHIE	ASS.CARTER FRONT. BELT PROTECT			
36	G16034960R	STAFFA ANT.SUPPORTO CARTER	CARTER SUPPORT FRONT BRACKET			
37	F01220011R	DADO M6X1 D980 8ZN	NUT M6X1 D980 8ZN	ECROU M6X1 D980 8 ZN	MUTTER M6X1 D980 8 ZN	TUERCA M6X1 D980 8 ZN
38	F05150403R	CUFFIA PROTEZ.CARDANO X GRUPPO	POWER TAKE-OFF PROTECTION HOUS	PROTECTEUR PRISE DE PUISSANCE	SCHUTZKASTEN KRAFTABTRIEB	ENVOLTURA PROTECCI N T. DE P.
39	G19002131R	PROTEZIONE P.D.P.	PDP GUARD			
40	F08011716R	CARD.B1 Z6-Z6 L900 R.LIB	UNIV.JOINT B1 Z6-Z6 L900 R.LIB	CARD.B1 Z6-Z6 L900 R.LIB	KARDAN CE T100710 112 R12	CARDAN CE T100710 112 R12
41	F01420036R	ROS.M6 6,4X 18X1,5 U6593 ZN	WASHER M6 6,4X 18X1,5 U6593 ZN	RONDELLE M6 6,4X18X1,5 U6593ZN	SCHEIBEN M6 6,4X18X1,5U6593 ZN	ARANDELA M6 6,4X18X1,5U6593ZN
42	F01420060R	ROS.M10 10,5X 30X2,5 U6593 ZG	GALV.WASHER 10,5X30X2,5 U6593	RONDELLE 10,5X30	SCHEIBE 10,5X30	ARANDELA 10,5X30

<<type A>>

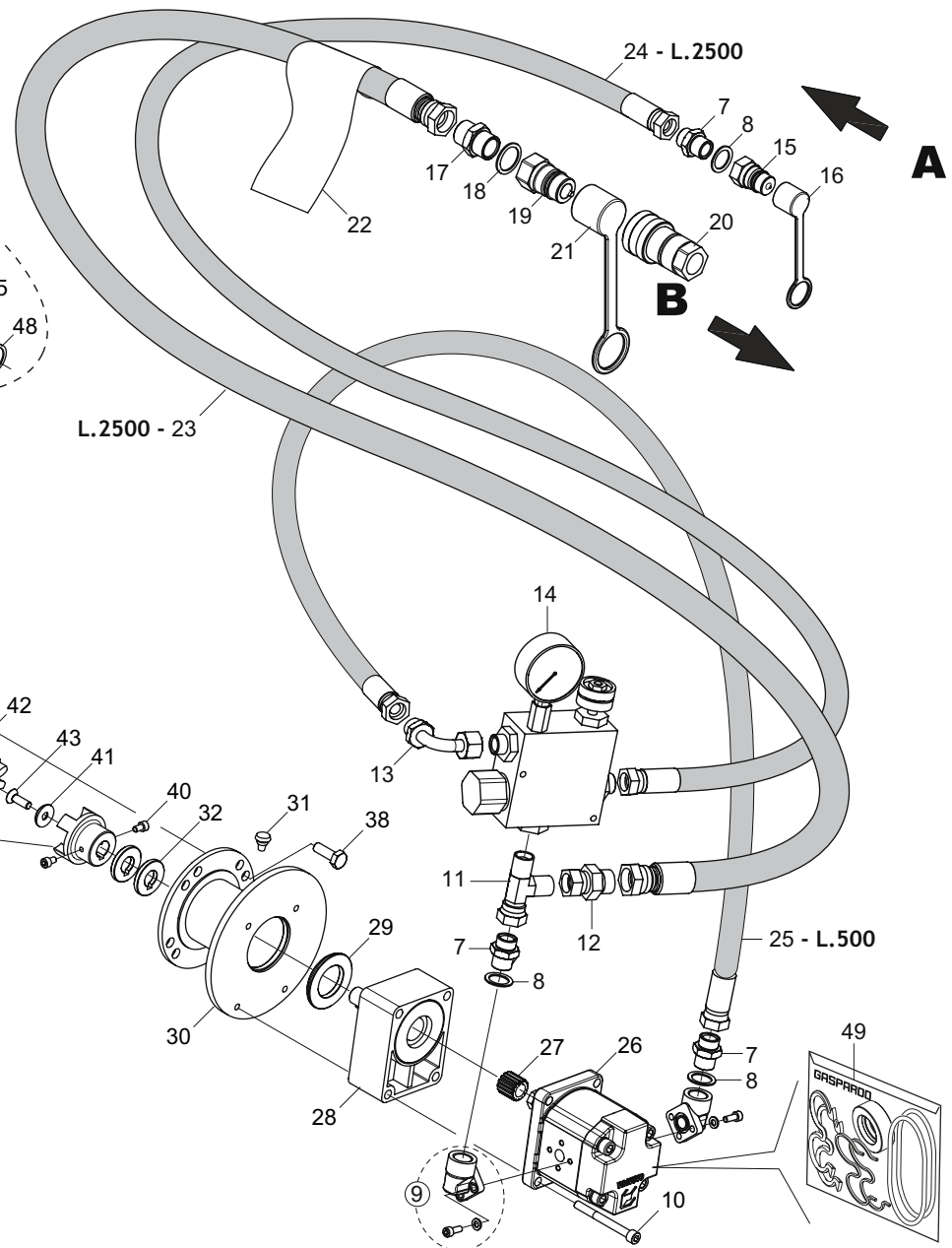
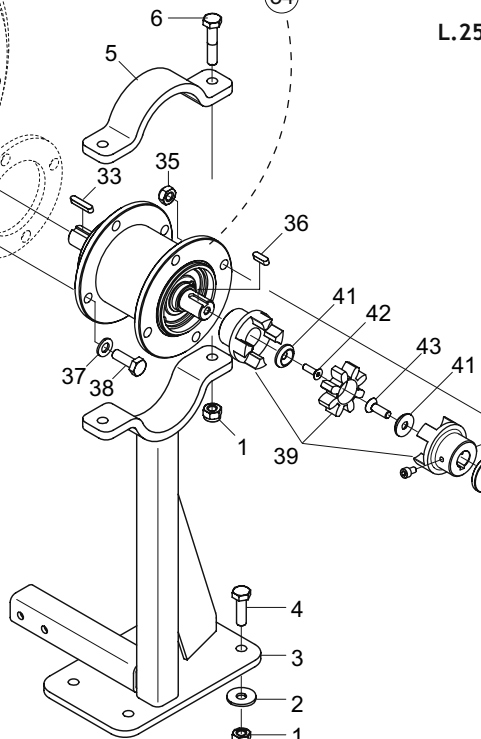
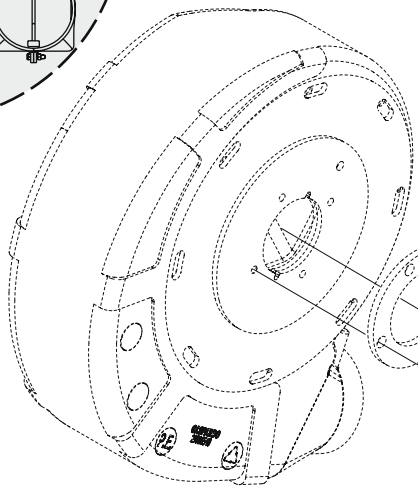
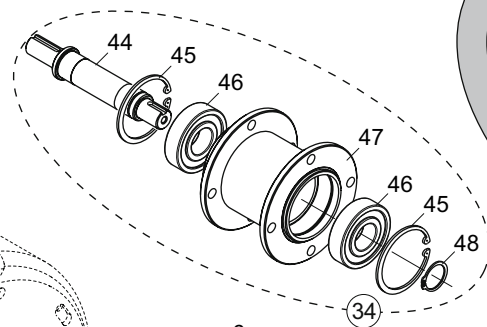
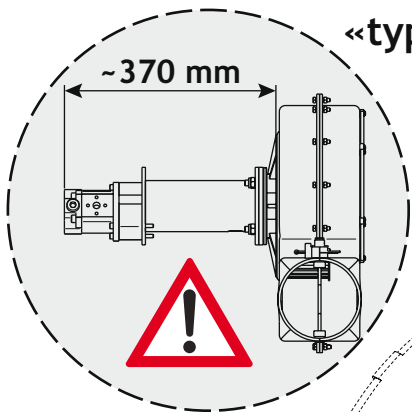

A - Mandata OLIO - In OIL flux
Portata MAX di olio = 35 litri/min. ad una pressione di 150 bar.

B - Ritorno OLIO - Out OIL flux

N.B.

Collegare il tubo di ritorno (B) direttamente a scarico tramite l'apposito innesto in assenza di pressione. Se il trattore non ne fosse provvisto, consultare la **Casa Costruttrice** dello stesso.

Non si deve assolutamente usare il distributore idraulico per il ritorno dell'olio.

**SOFFIANTE AD AZIONAMENTO OLEODINAMICO DIPENDENTE «TIPO A»
FAN DRIVE BY HYDRAULIC DEPENDENT SYSTEM «TYPE A»**

TAV. 170

Pos.	Cod.	Descrizione	Description	Description	Benennung	Description
1	F01230048R	DADO M10X1,5 D982 8ZN	NUT M10X1,5 D982 8ZN	ECR.AUTO-FREIN.M10X1,5 D982 ZN	SICHERUNGSMUTT.M10X1,5 D982 ZN	TUERCA SEGURID.M10X1,5 D982 ZN
2	F01420060R	ROS.M10 10,5X 30X2,5 U6593 ZG	GALV.WASHER 10,5X30X2,5 U6593	RONDELLE 10,5X30	SCHEIBE 10,5X30	ARANDELA 10,5X30
3	G16035280R	SUPPORTO VENTOLA	FAN SUPPORT			
4	F01020479R	VITE M10X1,5X35 U5739 8.8ZN	SCR. M10X1,5X35 U5739 8.8ZN	VIS M10X1,5X35 U5739 8.8 ZN	SCHR. M10X1,5X35 U5739 8.8 ZN	TORN. M10X1,5X35 U5739 8.8 ZN
5	G16050440R	CHIUSURA SUP.	CLOSURE	FERMETURE	VERSCHLUSS	CIERRE
6	F01020114R	VITE M10X1,5X50 U5737 8.8ZN	SCR. M10X1,5X50 U5737 8.8ZN	VIS M10X 1,5X50 U5737 8.8 ZN	SCHRA.M10X 1,5X50 U5737 8.8 ZN	TORN. M10X 1,5X50 U5737 8.8 ZN
7	F03150255R	NIPPLO MASCH.CIL.1 2-1 2 ZN	NIPPLE M. CYL. 1 2-1 2 ZN	NIPLE M. CYL. 1 2 - 1 2 ZN	NIPLE F. ZYL. 1 2-1 2 ZN	NIPLE M. CIL. 1 2 - 1 2 ZN
8	F03151237R	ROS. 21 X27X1,5 RAME -1 2	COPPER WASHER 21X27X1,5 1 2	RONDELLE CUIVRE 21X27X1,5 1 2	SCHEIBE KUPFER 21X27X1,5 1 2	ARANDELA COBRE 21X27X1,5 1 2
9	F03151203R	KIT RACCORDO A GOMITO 1 2	1 2 ANGLED UNION	RACCORD A COUDE	WINKELANSCHLUSSTSCK 1 2	CODO DE UNI N 1 2
10	F01040108R	VITE M8X1,25X80 U5931 8.8ZN	SCR. M8X1,25X80 U5931 8.8ZN			
11	F03151208R	RACCORDO L 2M1 2 F1 2 ZN	UNION L2 M1 2 F1 2 ZN	RACCORD L2 M1 2 F1 2 ZN	ANSCHLUSSTSCK L2 M1 2 F1 2 ZN	UNION L2 M1 2 F1 2 ZN
12	F03150089R	NIPPLO M3 4-F1 2 GIREVOLE ZN	NIPPLE M3 4-F1 2 REVOLVING ZN	NIPPLE M3 4-F1 2 TOURNANT ZN	NIPPELZYL. M3 4-F1 2 DREHBAR	NIPLE M3 4-F1 2 GIRATORIO ZN
13	F03150858R	CURVA 90 F.GIREV.1 2 - M.1 2	ELBOW 90 F.SLEWING 1 2 - M.1 2			
14	F03150540R	VALVOLA PRIORIT.MANOM.P0558086	MANOMETER PRIORITY VALVE	VANNE PRIORITAIRE MANOM TRE	PRIORIT-TSVENTIL MANOMETER	V-LVULA PRIORITARIA MAN METRO
15	F03150935R	INNESTO RAP.MASCH.1 2 A VALV.	QUICK CONNECT MALE CONE 1 2	CONNEXION RAPIDE MALE CONE 1 2	SCHNELLKUPP.GEWINDE KONISC 1 2	ACOPLAMIEN.RAP.MACHO CONO 1 2
16	F05150325R	CAPPUC.F X INN.M RAP.1 2 ROSS	COVER CONNECT F 1 2 RED	COUVERCLE CONNEXION F 1 2 ROSE	DECKEL W 1 2 SCHNELLKUPP. ROT	PAC PROTECCION F 1 2 ROJO
17	F03020009R	NIPPLO DI GIUNZIONE BSP 3 4-1	JUNCTION NIPPLE BSP 3 4-14	NIPPLE DE JUNCTION BSP 3 4-14	NIPPEL BSP 3 4 - 14	NIPLO DE JUNCION BSP 3 4-14
18	F03150984R	ROSETTA IN RAME 27X33X1,5 3 4	WASHER 27X33X1,5 3 4 CU	ROSETTE 27X33X1,5 3 4 CU	SCHEIBE 27X33X1,5 3 4 CU	ARANDELLA 27X33X1,5 3 4 CU
19	F03150936R	INNESTO RAP.MASCH.3 4 A VALV.	QUICK CONNECT MALE CONE 3 4 CO	PRISE A BILLE MALE CONE 3 4	SCHNELLKUPPLUNG GEWINDE KONISC	ACOPLAMIENTO R PIDO MACHO CONO
20	F03150949R	INNESTO RAP.FEMM.3 4 A VALV.	QUICK-CONNECT 3 4 VALVE FEM.	PRISE A BILLE F ELLE CONE 3 4	SCHNELLKUPPLUNG NUT 3 4	ACOPLA. R P.HEMB.3 4 V LVULA
21	F05150493R	TAPPO INNESTO MASCHIO TF34	TF 34 MALE CONNECTION PLUG	CLAPET ACCOUPLEMENT MALE TF34	PFROPFEN KUPPLUNG GEWINDEZAPFE	TAPA ACOPLAMIENTO MACHO TF34
22	G19704520R	DECALCOMANIA NON COLL.AL DISTR	LAB.DON T CONNECT WITH DISTR.			
23	G17930500R	TUBO 3 4R2 F3 4-F3 4 2500	PIPE 3 4R2 F3 4-F3 4 2500	TUBE 3 4R2 F3 4-F3 4 2500	ROHR 3 4R2 F3 4-F3 4 2500	TUBO 3 4R2 F3 4-F3 4 2500
24	G15355300R	TUBO 1 2 R2 F1 2-F1 2 L.2500	PIPE 1 2 R2 F1 2-F1 2 L.2500	TUBE 1 2 R2 F1 2-F1 2 L.2500	ROHR 1 2 R2 F1 2-F1 2 L.2500	TUBO 1 2 R2 F1 2-F1 2 L.2500
25	G15355340R	TUBO 1 2R2 F1 2- F1 2 500	PIPE 1 2R2 F1 2- F1 2 500	TUBE 1 2R2 F1 2- F1 2 500	ROHR 1 2R2 F1 2- F1 2 500	TUBO 1 2R2 F1 2- F1 2 500
26	F03150998R	MOTORE PLM 20,8 DX ANTICAV.	MOTOR PLM 20,8 DX ANTICAV			
27	F03151249R	SEMIGIUNTO ALBERO CONICO POMPA	SEMI-COUPPLING PUMP TAPER-SHAFT			
28	F03150924R	TENDICINGHIA X PLM 20,8	BELT STRETCHER PLM 20,8			
29	G17350210R	ANELLO ZN	GALVAN RING	BAGUE ZN	RING ZN	ANILLO ZN
30	G17350220R	ASS.MOZZO X MOTORE PLM 20,8	HUB SET FOR ENGINE PLM20,8			
31	G66248223R	TAPPO SUPP.SPAND.D.11	PLUG MAN. SPR. SUPP. D.11	BOUCHON SUPPORT EP. ENGRAIS D.	HALTERUNGSPFROPFEN DSNGERSTR.	TAP N SOPORTE ABON.D.11
32	G16150220R	DISTANZIALE ZN	SPACER ZN			
33	F02150038R	LINGUETTA 6X 6X 30 U6604A	PARALLEL KEY 6X 6X 30 U6604A	LANGUETTE 06X6X30 UNI6604	FEDERKEIL 06X6X30 UNI6604	LENGSETA 06X6X30 UNI6604
34	G16050830R	MOZZO VENTOLA IDRAULICA COMPL	FAN HUB HYDRAULIC			
35	F01220033R	DADO M10X1,5 D980 8ZN	NUT M10X1,5 D980 8ZN	ECROU M10X1,5 D980 8ZN	MUTTER M10X1,5 D980 8ZN	TUERCA M10X1,5 D980 8ZN
36	F02150036R	LINGUETTA 6X 6X 20 U6604A	PARALLEL KEY 6X 6X 20 U6604A	LANGUETTE 06X6X20 UNI6604	FEDERKEIL 06X6X20 UNI6604	LENGSETA 06X6X20 UNI6604
37	F01410064R	ROS.M10 10,5X 20X 2 U6592 ZN	WASHER M10 10,5X20X2 U6592 ZN	RONDEL. M10 10,5X20X2 U6592 ZN	SCHEIBE M10 10,5X20X2 U6592 ZN	ARANDEL.M10 10,5X20X2 U6592 ZN
38	F01020476R	VITE M10X1,5X30 U5739 8.8ZN	SCR. M10X1,5X30 U5739 8.8ZN	VIS M10X1,5X30 U5739 8.8 ZN	SCHRAUBE M10X1,5X30U5739 8.8ZN	TORNIL.M10X1,5X30 U5739 8.8 ZN
39	G15355490R	GIUNTO ELASTICO D.18-22	LOCK COUPLING D.18-22	JOINT DE BLOCAGE D.18-22	SPERRKUPPLUNG D.18-22	JUNTA DE BLOQUEO D.18-22
40	F01040058R	VITE M6X1X10 U5931 8.8ZN	SCREW M6X1X10 U5931 8.8ZN	VIS M6X1X10 U5931 8.8ZN	SCHRAUBE M6X1X10 U5931 8.8ZN	TORNILLO M6X1X10 U5931 8.8ZN
41	G15355500R	RONDELLA AUTOCENTRANTE ZN	SELF-CENTERING WASHER ZN	RONDELLE AUTOCENTREE ZN	SELBSTZENTR.UNTERLEGGSCH. ZN	ARANDELA AUTOCENTRADORA ZN
42	F01030038R	VITE M6X1X20 U5933 10.9ZD	SCR. M6X1X20 U5933 10.9ZD	VIS M6X1X20 U5933 10.9ZD	SCHRAU. M6X1X20 U5933 10.9ZD	TORNILLO M6X1X20 U5933 10.9ZD
43	F01030056R	VITE M8X1,25X25 U5933 10.9ZD	SCR. M8X1,25X25 U5933 10.9ZD	VIS 8X25 5933 10.9 ZN	SCHRAUBE 8X25 5933 10.9 ZN	TORNILLO 8X25 5933 10.9 ZN
44	G16050840R	ASSE D.36 X 191,5	AXLE D.36 X 191,5			
45	F02050403R	ANELLO E. DI 72X 2,5 U7437 C7	SEEGER RING E.72X2,5 U7437 C70	SEEGER E. 72X 2,5 U7437 C70	SEEGERING E. 72X 2,5 U7437 C70	ANILLO E. 72X 2,5 U7437 C70
46	F04010215R	CUSC.D30 D72 B19 6306 2RSC3 EX	BEARING D30 D72 B19 6306 2RSC3	ROULEMENT	LAGER 6306 2RS C3	COJINETE 6306 2RS C3
47	G16050850R	MOZZO VENTOLA IDRAULICA	FAN HUB HYDRAULIC			
48	F02050112R	ANELLO E.DE 30X 1,5 U7435 ZN	SEEGER RING 30X 1,5 U7435 C70	SEEGER E. 30 X 1,5 U7435 C70	SEEGERING E. 30X 1,5 U7435 C70	ANILLO E. 30 X 1,5 U7435 C70
49	F03100224R	KIT GUAR.MOTORE DX20,8ANTICAV.	KIT O-RING ENGINE DX20,8			

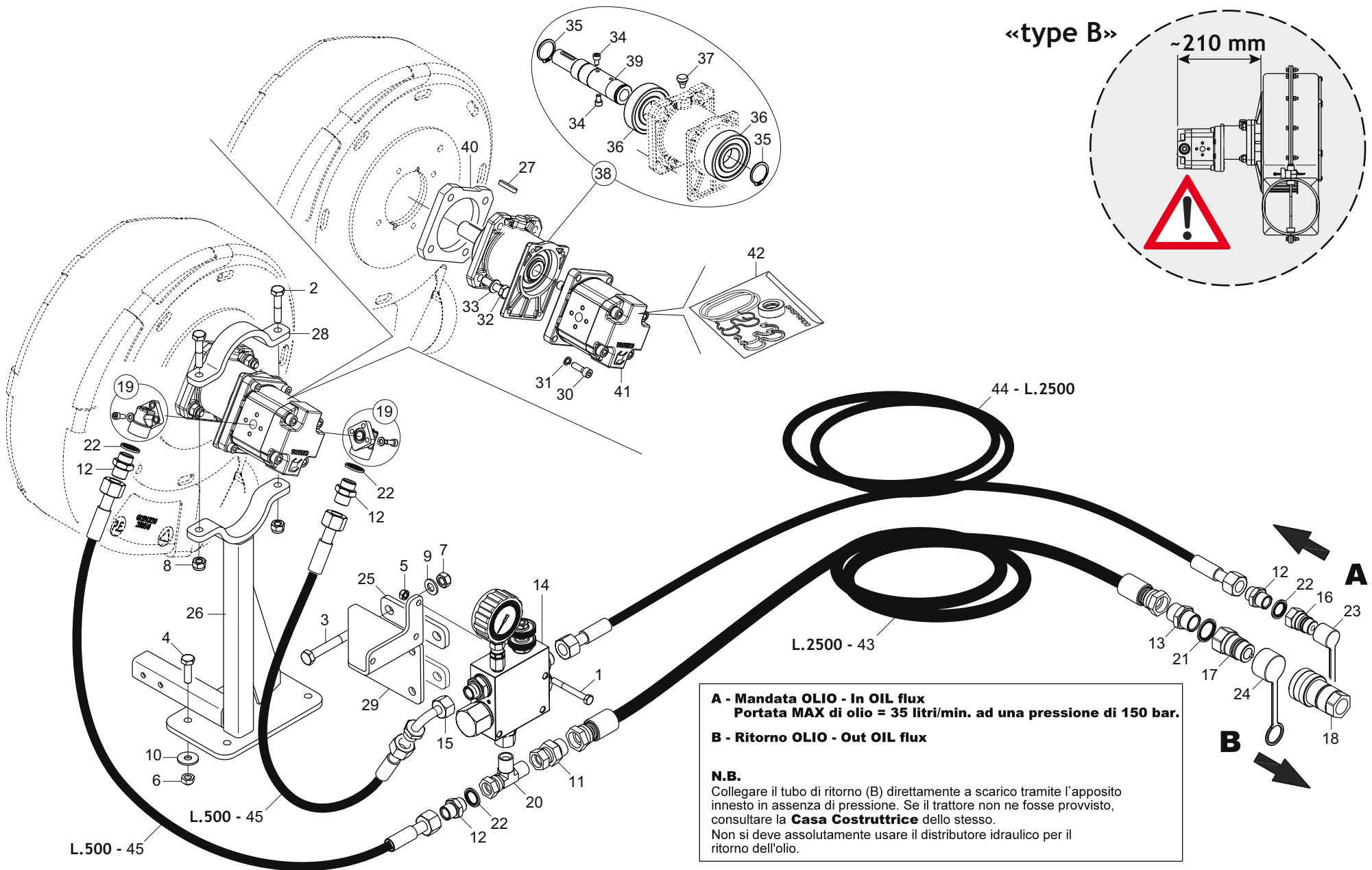

**SOFFIANTE AD AZIONAMENTO OLEODINAMICO DIPENDENTE «TIPO B»
FAN DRIVE BY HYDRAULIC DEPENDENT SYSTEM «TYPE B»**

TAV. 171

Pos.	Cod.	Descrizione	Description	Description	Benennung	Descripcion
1	F01020083R	VITE M8X1,25X70 U5737 8.8ZN	SCR. M8X1,25X70 U5737 8.8ZN	VIS M 8X1,25X 70 U5737 8.8 ZN	SCHRA. M8X1,25X70 U5737 8.8ZN	TORN. M 8X1,25X 70 U5737 8.8ZN
2	F01020114R	VITE M10X1,5X50 U5737 8.8ZN	SCR. M10X1,5X50 U5737 8.8ZN	VIS M10X 1,5X50 U5737 8.8 ZN	SCHRA.M10X 1,5X50 U5737 8.8 ZN	TORN. M10X 1,5X50 U5737 8.8 ZN
3	F01020168R	VITE M12X1,75X90 U5737 8.8ZN	SCR. M12X1,75X90 U5737 8.8ZN	VIS M12X1,75X90 U5737 8.8 ZN	SCHHRAB.M12X1,75X90 5737 8.8 ZN	TORNIL.M12X1,75X90 5737 8.8 ZN
4	F01020479R	VITE M10X1,5X35 U5739 8.8ZN	SCR. M10X1,5X35 U5739 8.8ZN	VIS M10X1,5X35 U5739 8.8 ZN	SCHR. M10X1,5X35 U5739 8.8 ZN	TORN. M10X1,5X35 U5739 8.8 ZN
5	F01220022R	DADO M8X1,25 D980 8ZN	NUT M8X1,25 D980 8ZN	ECROU M8X 1,25 D980 8 ZN	MUTTER M8X 1,25 D980 8 ZN	TUERCA M8X 1,25 D980 8 ZN
6	F01220033R	DADO M10X1,5 D980 8ZN	NUT M10X1,5 D980 8ZN	ECROU M10X1,5 D980 8ZN	MUTTER M10X1,5 D980 8ZN	TUERCA M10X1,5 D980 8ZN
7	F01220048R	DADO M12X1,75 D980 8ZN	NUT M12X1,75 D980 8ZN	ECROU M12X1,75 D980 8 ZN	SCHEIBE M12X1,75 D980 8 ZN	TUERCA M12X1,75 D980 8 ZN
8	F01230048R	DADO M10X1,5 D982 8ZN	NUT M10X1,5 D982 8ZN	ECR.AUTO-FREIN.M10X1,5 D982 ZN	SICHERUNGSMUTT.M10X1,5 D982 ZN	TUERCA SEGURID.M10X1,5 D982 ZN
9	F01410076R	ROS.M12 13X 24X2,5 U6592 ZN	WASHER 12 13X 24X2,5 U6592 ZN	RONDEL. M12 13X24X2,5 U6592 ZN	SCHEIBE M12 13X24X2,5 U6592 ZN	ARANDELA M12 13 X24X2,5 ZN
10	F01420060R	ROS.M10 10,5X 30X2,5 U6593 ZG	GALV.WASHER 10,5X30X2,5 U6593	RONDELLE 10,5X30	SCHEIBE 10,5X30	ARANDELA M10,5X30
11	F03150089R	NIPPLO M3 4-F1 2 GIREVOLE ZN	NIPPLE M3 4-F1 2 REVOLVING ZN	NIPPLE M3 4-F1 2 TOURNANT ZN	NIPPELZYL. M3 4-F1 2 DREHBAR	NIPLE M3 4-F1 2 GIRATORIO ZN
12	F03150255R	NIPPLO MASCH.CIL.1 2-1 2 ZN	NIPPLE M. CYL. 1 2-1 2 ZN	NIPLE M. CYL. 1 2 - 1 2 ZN	NIPLE F. ZYL. 1 2-1 2 ZN	NIPLE M. CIL. 1 2 - 1 2 ZN
13	F03020009R	NIPPLO DI GIUNZIONE BSP 3 4-1	JUNCTION NIPPLE BSP 3 4-14	NIPPLE DE JUNCTION BSP 3 4-14	NIPPEL BSP 3 4 - 14	NIPLO DE JUNCION BSP 3 4-14
14	F03150540R	VALVOLA PRIORIT.MANOM.P0558086	MANOMETER PRIORITY VALVE	VANNE PRIORITAIRE MANOM TRE	PRIORIT-TSVENTIL MANOMETER	V-LVULA PRIORITARIA MAN METRO
15	F03150858R	CURVA 90 F.GIREV.1 2 - M.1 2	ELBOW 90 F.SLEWING 1 2 - M.1 2			
16	F03150935R	INNESTO RAP.MASCH.1 2 A VALV.	QUICK CONNECT MALE CONE 1 2	CONNEXION RAPIDE MALE CONE 1 2	SCHNELLKUPP.GEWINDE KONISC 1 2	ACOPLAMIENT.RAP.MACHO CONO 1 2
17	F03150936R	INNESTO RAP.MASCH.3 4 A VALV.	QUICK CONNECT MALE CONE 3 4 CO	PRISE A BILLE MALE CONE 3 4	SCHNELLKUPPLUNG GEWINDE KONISC	ACOPLAMIENTO R PIDO MACHO CONO
18	F03150949R	INNESTO RAP.FEMM.3 4 A VALV.	QUICK-CONNECT 3 4 VALVE FEM.	PRISE A BILLE F ELLE CONE 3 4	SCHNELLKUPPLUNG NUT 3 4	ACOPLA. R P.HEMB.3 4 V LVULA
19	F03151203R	KIT RACCORDO A GOMITO 1 2	1 2 ANGLED UNION	RACCORD A COUDE	WINKELANSCHLUSSTSCK 1 2	CODO DE UNI N 1 2
20	F03151208R	RACCORDO L 2M1 2 F1 2 ZN	UNION L2 M1 2 F1 2 ZN	RACCORD L2 M1 2 F1 2 ZN	ANSCHLUSSTSCK L2 M1 2 F1 2 ZN	UNION L2 M1 2 F1 2 ZN
21	F03151415R	RONDELLA BONDED SEAL 3 4 NBR	WASHER BONDED SEAL 3 4 NBR			
22	F03151370R	RONDELLA BONDED SEAL 1 2 NBR	WASHER BONDED SEAL 1 2 NBR			
23	F05150325R	CAPPUC.F X INN.M RAP.1 2 ROSS	COVER CONNECT F 1 2 RED	COUVERCLE CONNEXION F 1 2 ROSE	DECKEL W 1 2 SCHNELLKUPP. ROT	PAC PROTECCION F 1 2 ROJO
24	F05150493R	TAPPO INNESTO MASCHIO TF34	TF 34 MALE CONNECTION PLUG	CLAPET ACCOUPLEMENT MALE TF34	PFRROPFEN KUPPLUNG GEWINDEZAPFE	TAPA ACOPLAMIENTO MACHO TF34
25	G15470170R	SCONTRO 35 X130 X8	STRIKER 35 X130 X8	BUTEE 35 X130 X8	ANSCHLAG 35 X130 X8	ELEMENTO DE EMPALME 35 X130 X8
26	G16035281R	ASS.SUPP.VENTOLA	ASS.SUPPORT FAN			
27	F02150038R	LINGUETTA 6X 6X 30 U6604A	PARALLEL KEY 6X 6X 30 U6604A	LANGUETTE 06X6X30 UNI6604	FEDERKEIL 06X6X30 UNI6604	LENGSETA 06X6X30 UNI6604
28	G16051120R	CHIUSURA SUP.L30	CLOSURE SUP.L30			
29	G16051200R	SUPP.VALVOLA PRIORIT.	SUPPORT VALVE			
30	F01040601R	VITE M8X1,25X25 U5931 8.8ZD	SCR. M8X1,25X25 U5931 8.8ZD	VIS M8 X1,25X25 U5931 8.8 ZD	SCHRAUBE M8X1,25X25U5931 8.8ZD	TORNILLO M8X1,25X25U5931 8.8ZD
31	F01480033R	ROS.G 8,1X 12,7X 2 D7980 ZN	GROVER WASHER D8,1X12,7D7980ZN	ROND.ELASTIQ D8,1X12,7 D7980ZN	FEDERRINGE D8,1X12,7 D7980 ZN	ARAND.ELICOI.D8,1X12,7 D7980ZN
32	F01020483R	VITE M10X1,5X40 U5739 10.9ZD	SCR. M10X1,5X40 U5739 10.9ZD	VIS M10X1,5X40 U5739 10.9 ZD	SCHRA.M10X1,5X40 U5739 10.9 ZD	TORN. M10X1,5X40 U5739 10.9 ZD
33	F01410064R	ROS.M10 10,5X 20X 2 U6592 ZN	WASHER M10 10,5X20X2 U6592 ZN	RONDEL. M10 10,5X20X2 U6592 ZN	SCHEIBE M10 10,5X20X2 U6592 ZN	ARANDEL.M10 10,5X20X2 U6592 ZN
34	F01040058R	VITE M6X1X10 U5931 8.8ZN	SCREW M6X1X10 U5931 8.8ZN	VIS M6X1X10 U5931 8.8ZN	SCHRAUBE M6X1X10 U5931 8.8ZN	TORNILLO M6X1X10 U5931 8.8ZN
35	F02050112R	ANELLO E.DE 30X 1,5 U7435 ZN	SEEGER RING 30X 1,5 U7435 C70	SEEGER E. 30 X 1,5 U7435 C70	SEEGERING E. 30X 1,5 U7435 C70	ANILLO E. 30 X 1,5 U7435 C70
36	F04010215R	CUSC.D30 D72 B19 6306 2RSC3 EX	BEARING D30 D72 B19 6306 2RSC3	ROULEMENT	LAGER 6306 2RS C3	COJINETE 6306 2RS C3
37	G66248223R	TAPPO SUPP.SPAND.D.11	PLUG MAN. SPR. SUPP. D.11	BOUCHON SUPPORT EP. ENGRAIS D.	HALTERUNGSPFRROPFEN DSNGERSTR.	TAP N SOPORTE ABON.D.11
38	GA5250140R	MONT.MOZZO CUSC.ALB.D.22	ASS.HUB BEARING SHAFT D.22			
39	GA5250120R	ALBERO VENTOLA D.22	SHAFT FAN D.22			
40	GA5250100R	FLANGIA 115X115X12 D.85	FLANGE 115X115X12 D.85			
41	F03150998R	MOTORE PLM 20,8 DX ANTICAV.	MOTOR PLM 20,8 DX ANTICAV			
42	F03100224R	KIT GUAR.MOTORE DX20,8ANTICAV.	KIT O-RING ENGINE DX20,8			
43	G17930500R	TUBO 3 4R2 F3 4-F3 4 2500	PIPE 3 4R2 F3 4-F3 4 2500	TUBE 3 4R2 F3 4-F3 4 2500	ROHR 3 4R2 F3 4-F3 4 2500	TUBO 3 4R2 F3 4-F3 4 2500
44	G15355300R	TUBO 1 2 R2 F1 2-F1 2 L.2500	PIPE 1 2 R2 F1 2-F1 2 L.2500	TUBE 1 2 R2 F1 2-F1 2 L.2500	ROHR 1 2 R2 F1 2-F1 2 L.2500	TUBO 1 2 R2 F1 2-F1 2 L.2500
45	G15355340R	TUBO 1 2R2 F1 2- F1 2 500	PIPE 1 2R2 F1 2- F1 2 500	TUBE 1 2R2 F1 2- F1 2 500	ROHR 1 2R2 F1 2- F1 2 500	TUBO 1 2R2 F1 2- F1 2 500

«type A»

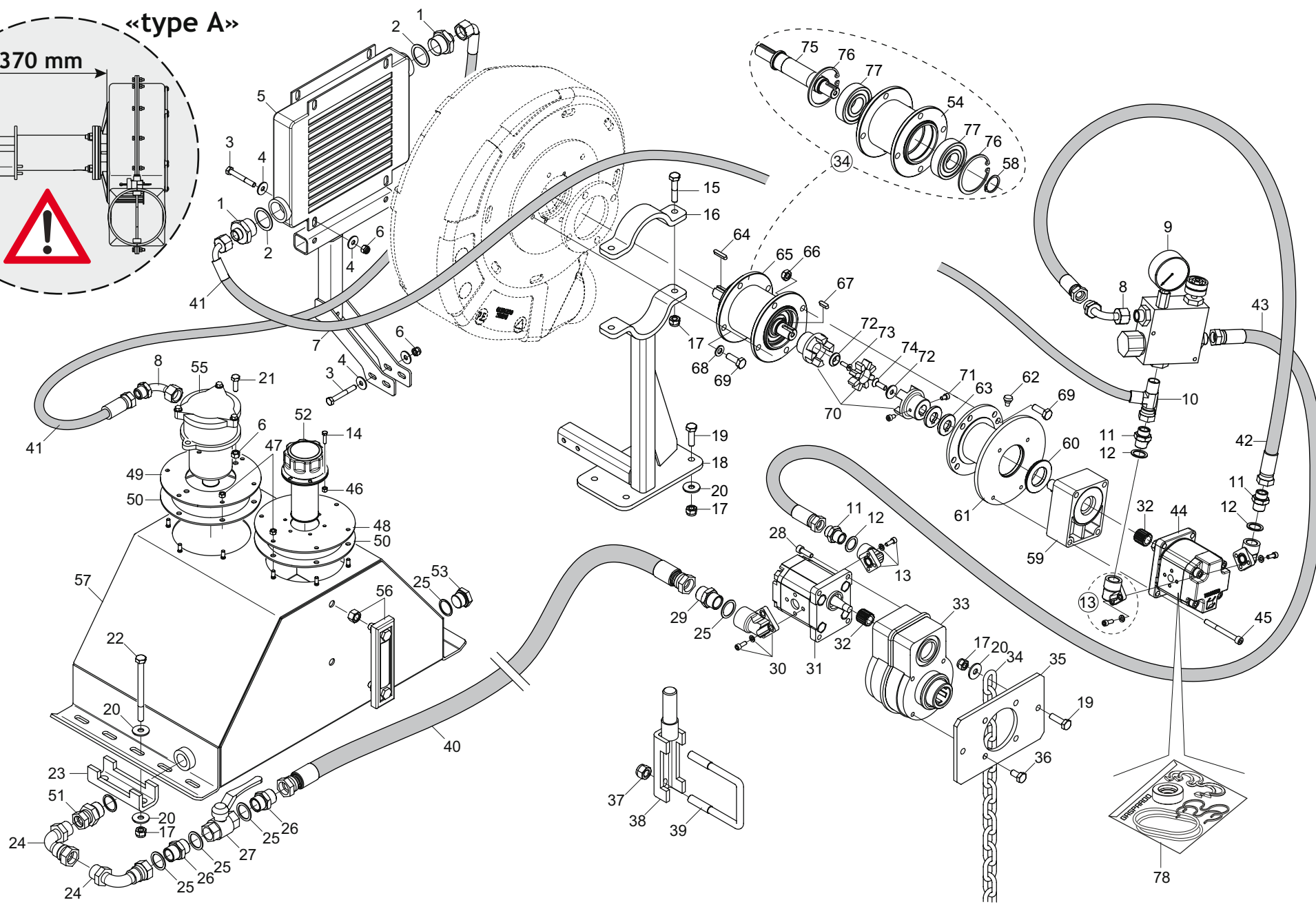
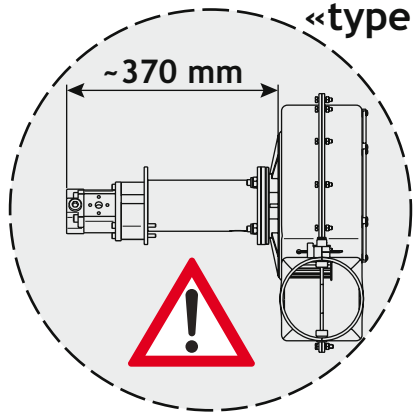

**SOFFIANTE AD AZIONAMENTO OLEODINAMICO INDIPENDENTE «TIPO A»
FAN DRIVE BY HYDRAULIC INDEPENDENT SYSTEM «TYPE A»**

TAV. 180

Pos.	Cod.	Descrizione	Description	Description	Benennung	Description
1	F03150180R	NIPPLO MASCH.CIL.1-1 2 ZN.	NIPPLE M. CYL. 1-1 2 ZN.			
2	F03150985R	ROS. 33,6X41X1,5 RAME -1	WASHER 1 33,6X41X1,5	RONDELLE CUIVRE 1	KUPFERSCHEIBE 1	ARANDELA 1
3	F01020077R	VITE M8X1,25X60 U5737 8.8ZN	SCR. M8X1,25X60 U5737 8.8ZN	VIS M8X1,25X60 U5737 8.8 ZN	SCHRAU. M8X1,25X60 U5737 8.8ZN	TORN. M8X1,25X60 U5737 8.8 ZN
4	F01420048R	ROS.M8 8,4X 24X 2 U6593 ZN	WASHER M8 8,4X 24X2 U6593 ZN	RONDELLE M8 8,4X24X 2 U6593 ZN	SCHEIBEN M8 8,4X24X 2 U6593 ZN	ARANDELA M8 8,4X 24X2 U6593 ZN
5	F03151248R	SCAMBIATORE ARIA-OLIO	AIR-OIL HEAT EXCHANGER	ECHANGEUR AIR-HUILE	AUSTAUSCHER LUFT TL	INTERCAMBIADOR AIRE-ACEITE
6	F01230034R	DADO M8X1,25 D982 8ZN	NUT M8X1,25 D982 8ZN	ECROU M8X 1,25 ZN	MUTTER M8X 1,25 D982 8 ZN	TUERCA M8X 1,25 D982 8 ZN
7	G16035320R	SUPPORTO RADIATORE	EXCHANGER SUPPORT			
8	F03150858R	CURVA 90 F.GIREV.1 2 - M.1 2	ELBOW 90 F.SLEWING 1 2 - M.1 2			
9	F03150540R	VALVOLA PRIORIT.MANOM.P0558086	MANOMETER PRIORITY VALVE	VANNE PRIORITAIRE MANOM TRE	PRIORIT-TSVENTIL MANOMETER	V-LVJULA PRIORITARIA MAN METRO
10	F03151208R	RACCORDO L 2M1 2 F1 2 ZN	UNION L2 M1 2 F1 2 ZN	RACCORD L2 M1 2 F1 2 ZN	ANSCHLUSSTSCK L2 M1 2 F1 2 ZN	UNION L2 M1 2 F1 2 ZN
11	F03150255R	NIPPLO MASCH.CIL.1 2-1 2 ZN	NIPPLE M. CYL. 1 2-1 2 ZN	NIPLE M. CYL. 1 2 - 1 2 ZN	NIPLE F. ZYL. 1 2-1 2 ZN	NIPLE M. CIL. 1 2 - 1 2 ZN
12	F03151237R	ROS. 21 X27X1,5 RAME -1 2	COPPER WASHER 21X27X1,5 1 2	RONDELLE CUIVRE 21X27X1,5 1 2	SCHEIBE KUPFER 21X27X1,5 1 2	ARANDELA COBRE 21X27X1,5 1 2
13	F03151203R	KIT RACCORDO A GOMITO 1 2	1 2 ANGLED UNION	RACCORD A COUDE	WINKELANSCHLUSSTSCK 1 2	CODO DE UNI N 1 2
14	F01020380R	VITE M5X0,8X20 U5739 8.8ZN	SCR. M5X0,8X20 U5739 8.8ZN	VIS M5X0,8X20 U5739 8.8ZN	SCHRAUBE M5X0,8X20 U5739 8.8ZN	TORNILLO M5X0,8X20 U5739 8.8ZN
15	F01020114R	VITE M10X1,5X50 U5737 8.8ZN	SCR. M10X1,5X50 U5737 8.8ZN	VIS M10X 1,5X50 U5737 8.8 ZN	SCHRA.M10X 1,5X50 U5737 8.8 ZN	TORN. M10X 1,5X50 U5737 8.8 ZN
16	G16050440R	CHIUSURA SUP.	CLOSURE	FERMETURE	VERSCHLUSS	CIERRE
17	F01230048R	DADO M10X1,5 D982 8ZN	NUT M10X1,5 D982 8ZN	ECR.AUTO-FREIN.M10X1,5 D982 ZN	SICHERUNGSMUTT.M10X1,5 D982 ZN	TUERCA SEGURID.M10X1,5 D982 ZN
18	G16035280R	SUPPORTO VENTOLA	FAN SUPPORT			
19	F01020479R	VITE M10X1,5X35 U5739 8.8ZN	SCR. M10X1,5X35 U5739 8.8ZN	VIS M10X1,5X35 U5739 8.8 ZN	SCHR. M10X1,5X35 U5739 8.8 ZN	TORN. M10X1,5X35 U5739 8.8 ZN
20	F01420060R	ROS.M10 10,5X 30X2,5 U6593 ZG	GALV.WASHER 10,5X30X2,5 U6593	RONDELLE 10,5X30	SCHEIBE 10,5X30	ARANDELA 10,5X30
21	F01020440R	VITE M8X1,25X25 U5739 8.8ZN	SCR. M8X1,25X25 U5739 8.8ZN	VIS M8X1,25X25 U5739 8.8 ZN	SCHRAUBE M8X1,25X25U5739 8.8ZN	TORNIL.M8X1,25X25 U5739 8.8 ZN
22	F01020138R	VITE M10X1,5X130 U5737 8.8ZN	SCR. M10X1,5X130 U5737 8.8ZN	VIS M10X1,5 X130 U5737 8.8ZN	SCHRAU.M10X1,5X130 U5737 8.8ZN	TORNI. M10X1,5X130 U5737 8.8ZN
23	G36200241R	SCONTRO U 80	FLANGE U 80	BRIDE U 80	ANSCHLAG U 80	ELEMENTO DE EMPALME U 80
24	F03150856R	CURVA MF 3 4-3 4 GIR. 90	ELBOW 90 F. SWIVEL 3 4 -M.3 4	COUDE 90 F.TOURN.3 4 - M.3 4	KNIESTUCK 90 F.DREHB.3 4 - M.	CURVA 90 F.GIRAT.3 4 - M.3 4C
25	F03150984R	ROSETTA IN RAME 27X33X1,5 3 4	WASHER 27X33X1,5 3 4 CU	ROSETTE 27X33X1,5 3 4 CU	SCHIEBE 27X33X1,5 3 4 CU	ARANDELLA 27X33X1,5 3 4 CU
26	G15350010R	NIPPLO MM 3 4 TORNITO	NIPPLE MM 3 4			
27	F03151247R	SARACINESCA A LEVA F-F 3 4	LEVER-OPER. SLIDING VALVE 3 4	RIDEAU A LEVIER A LEVIER	HEBELFALLTSR 3 4	COMPUERTA DE PALANCA 3 4
28	F01040094R	VITE M8X1,25X25 U5931 A2IX	SCREW M8X1,25X25 U5931 A2IX	VIS M8X1,25X25 U5931 A2IX	SCHRAUBE M8X1,25X25 U5931 A2IX	TORNILLO M8X1,25X25 U5931 A2IX
29	F03020009R	NIPPLO DI GIUNZIONE BSP 3 4-1	JUNCTION NIPPLE BSP 3 4-14	NIPPLE DE JUNCTION BSP 3 4-14	NIPPEL BSP 3 4 - 14	NIPLO DE JUNCION BSP 3 4-14
30	F03151204R	KIT RACCORDO A GOMITO 3 4	3 4 ANGLED UNION	RACCORD A COUDE	WINKELANSCHLUSSTSCK 3 4	CODO DE UNI N 3 4
31	F03151188R	POMPA AD INGR.20,8 CC 540 G.	GEAR PUMP 22L.	POMPE A ENGRENAGES 22L. 540T	ZAHNRADPUMPE 22L.	BOMBA DE ENGRANAJES 22L.
32	F03151249R	SEMIGIUNTO ALBERO CONICO POMPA	SEMI-COUPLING PUMP TAPER-SHAFT			
33	F06260022R	MOLTIP.GIRI R.1 3 Z.6 540 G.	OVERDRIVE 1 3	MULTIPLICATEUR TOURS 1 3	DREHZAHLSBERSETZER 1 3	MULTIPLICADOR REVOL.1 3
34	G21120007R	CATENA LATO BRACCIO L.600	ARM SIDE CHAIN L.600	CHAINE COTE BRAS L. 600	KETTE ARMSEITE L 600	CADENA FLANCO BRAZO L.600
35	G15355190R	ATTACCO MOLTIPLICATORE	OVERGEAR COUPLING	FIXATION MULTIPLICATEUR	KUPPLUNG SBERSETZER	CONEXI N MOLTIPLICADOR
36	F01020470R	VITE M10X1,5X20 U5739 8.8ZN	SCR. M10X1,5X20 U5739 8.8ZN	VIS M10X1,5X20 U5739 8.8 ZN	SCHRAUBE M10X1,5X20 U5739 ZN	TORNILLOM10X1,5X20 U5739 8.8ZN
37	F01230073R	DADO M14X2 D982 8ZN	SELF LOCK NUT M14X2 D982 8ZN	ECROU AUTOBL.M14X2 ZN	SELBSTSP.MUTT. M14X2 D982 8ZN	TUERCA AUTOBL. M14X2 D982 8ZN
38	G16019270R	SUPPORTO MOLTIPLICATORE	MULTIPLICATOR SPRING			
39	F20110770R	CAV.Q.B=80 M=14X2 L=119	U BOLT Q.B=80 M=14X2 L=119	BRIDE U M14X2X50 96X119 ZN	ANSCHLANG U M14X2X50 96X119 ZN	EL.DE EMPALME M14X2X50 96X119
40	G17930500R	TUBO 3 4R2 F3 4-F3 4 2500	PIPE 3 4R2 F3 4-F3 4 2500	TUBE 3 4R2 F3 4-F3 4 2500	ROHR 3 4R2 F3 4-F3 4 2500	TUBO 3 4R2 F3 4-F3 4 2500
41	G15355630R	TUBO 1 2R2 CF1 2- F1 2 750	PIPE 1 2R2 CF1 2- F1 2 750	TUBE 1 2R2 CF1 2- F1 2 750	ROHR 1 2R2 CF1 2- F1 2 750	TUBO 1 2R2 CF1 2- F1 2 750
42	G15355340R	TUBO 1 2R2 F1 2- F1 2 500	PIPE 1 2R2 F1 2- F1 2 500	TUBE 1 2R2 F1 2- F1 2 500	ROHR 1 2R2 F1 2- F1 2 500	TUBO 1 2R2 F1 2- F1 2 500
43	G15355300R	TUBO 1 2 R2 F1 2-F1 2 L.2500	PIPE 1 2 R2 F1 2-F1 2 L.2500	TUBE 1 2 R2 F1 2-F1 2 L.2500	ROHR 1 2 R2 F1 2-F1 2 L.2500	TUBO 1 2 R2 F1 2-F1 2 L.2500
44	F03150998R	MOTORE PLM 20,8 DX ANTICAV.	MOTOR PLM 20,8 DX ANTICAV			
45	F01040108R	VITE M8X1,25X80 U5931 8.8ZN	SCR. M8X1,25X80 U5931 8.8ZN			
46	F01230019R	DADO M5X0,8 D982 8ZN	NUT M5X0,8 D982 8ZN	ECROU AUTOB.NOR.5 ZN	SELBSTSP. MUTTER NOR.5 ZN	TUERCAAUTOB. NOR. 5 ZN
47	F01230022R	DADO M6X1 D982 8ZN	NUT M6X1 D982 8ZN	ECROU AUTO-FREIN.M6X1 D982 8ZN	SICHERUNGSMUT. M6X1 D982 8 ZN	TUERCA DE SEGU.M6X1 D982 8 ZN
48	G15355700R	SUPPORTO TAPPO CAR.OLIO ZN	CLOSURE TAP SUPPORT	SUPPORT BOUCHON DE FERMETURE	HALTERUNG ABSCHLUSSPFROPFEN	SOPORTE TAPON DE CIERRE
49	G15355710R	SUPPORTO FILTRO OLIO DP ZN	CLOSURE FILTER	SUPPORT FILTRE	HALTERUNG FILTER	SOPORTE FILTRO
50	G15355720R	GUARNIZIONE IMP.OLEOD.	GASKET FOR HYDR.SYST.			
51	F03150078R	NIPPLO MF GIREVOLE 3 4 ZG CIL	NIPPLE M-F SWIVEL 3 4 ZINC.	NIPPLE M-F TOURNANT 3 4 ZING.	NIPPEL M-F DREHBAR 3 4 VERZINK	NIPLE M-H GIRATORIO 3 4 CINC.
52	F03150716R	TAPPO DI CARICAMENTO OLIO	INLET OIL PLUG	BOUCHON HUILE	TLSCHRAUBE	TAP N ACEITE
53	F03150720R	TAPPO MASCHIO 3 4 GAS	PLUG 3 4	BOUCHON	PFROPFEN 3 4	TAP N 3 4
54	G16050850R	MOZZO VENTOLA IDRAULICA	FAN HUB HYDRAULIC			
55	F03151147R	FILTRO	FILTER	FILTRE	FILTER	FILTRO

«type A»

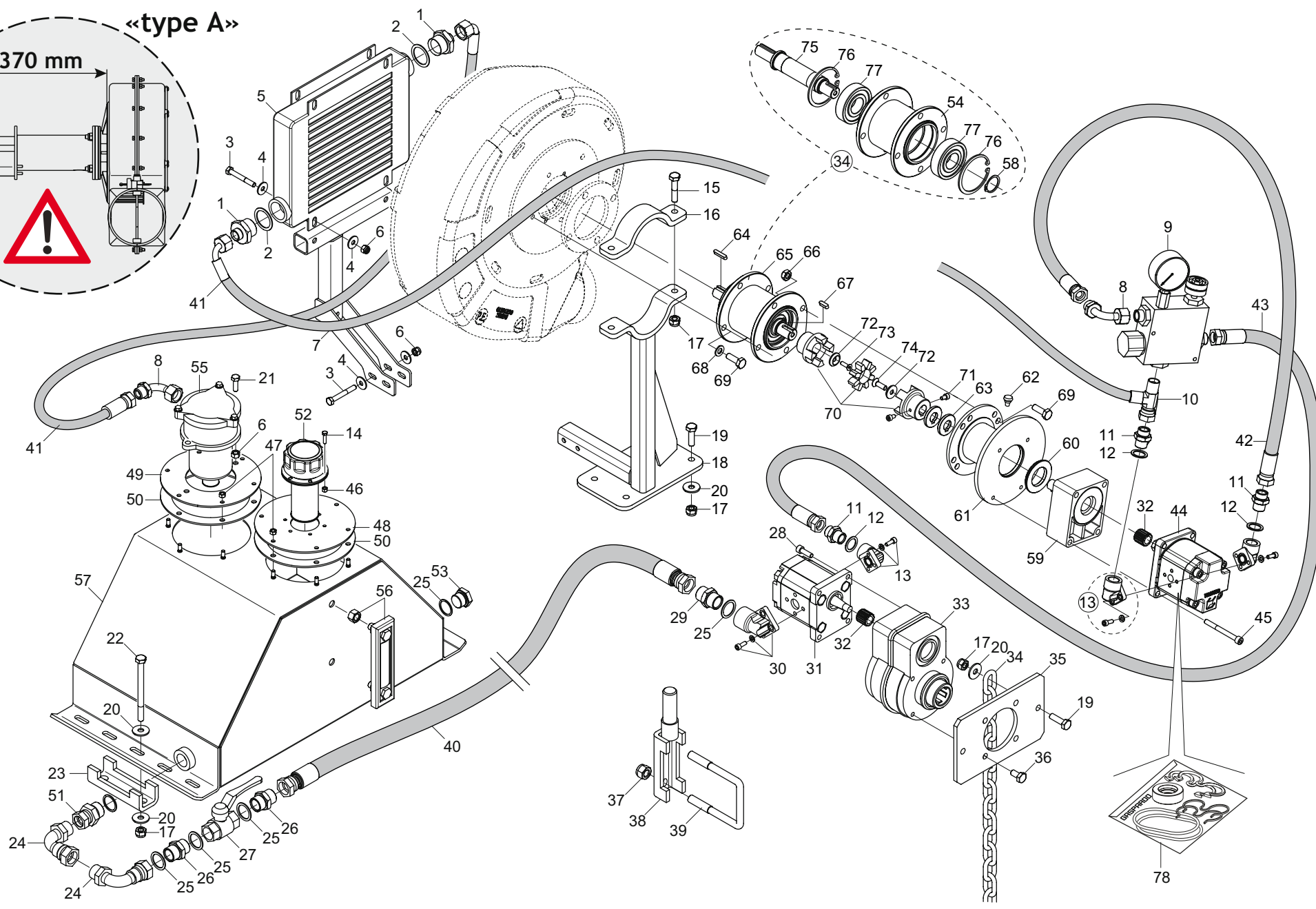
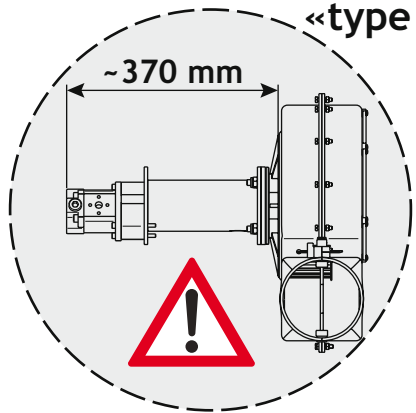

**SOFFIANTE AD AZIONAMENTO OLEODINAMICO INDIPENDENTE «TIPO A»
FAN DRIVE BY HYDRAULIC INDEPENDENT SYSTEM «TYPE A»**

TAV. 180

Pos.	Cod.	Descrizione	Description	Description	Benennung	Descripcion
56	F03151161R	LIVELLO OLIO CON TERMOMETRO	OIL LEVEL WITH THERMOMETER	NIVEAU HUILE AVEC THERMOMETRE	LSTAND MIT THERMOMETER	NIVEL ACEITE CON TERMOMETRO
57	G16070600R	SERBATOIO OLIO L.48	OIL TANK L.48			
58	F02050112R	ANELLO E.DE 30X 1,5 U7435 ZN	SEEGER RING 30X 1,5 U7435 C70	SEEGER E. 30 X 1,5 U7435 C70	SEEGERING E. 30X 1,5 U7435 C70	ANILLO E. 30 X 1,5 U7435 C70
59	F03150924R	TENDICINGHIA X PLM 20,8	BELT STRETCHER PLM 20,8			
60	G17350210R	ANELLO ZN	GALVAN RING	BAGUE ZN	RING ZN	ANILLO ZN
61	G17350220R	ASS.MOZZO X MOTORE PLM 20,8	HUB SET FOR ENGINE PLM20,8			
62	G66248223R	TAPPO SUPP.SPAND.D.11	PLUG MAN. SPR. SUPP. D.11	BOUCHON SUPPORT EP. ENGRAIS D.	HALTERUNGSPFROPFEN DSNGERSTR.	TAP N SOPORTE ABON.D.11
63	G16150220R	DISTANZIALE ZN	SPACER ZN			
64	F02150038R	LINGUETTA 6X 6X 30 U6604A	PARALLEL KEY 6X 6X 30 U6604A	LANGUETTE 06X6X30 UNI6604	FEDERKEIL 06X6X30 UNI6604	LENGSETA 06X6X30 UNI6604
65	G16050830R	MOZZO VENTOLA IDRAULICA COMPL	FAN HUB HYDRAULIC			
66	F01220033R	DADO M10X1,5 D980 8ZN	NUT M10X1,5 D980 8ZN	ECROU M10X1,5 D980 8ZN	MUTTER M10X1,5 D980 8ZN	TUERCA M10X1,5 D980 8ZN
67	F02150036R	LINGUETTA 6X 6X 20 U6604A	PARALLEL KEY 6X 6X 20 U6604A	LANGUETTE 06X6X20 UNI6604	FEDERKEIL 06X6X20 UNI6604	LENGSETA 06X6X20 UNI6604
68	F01410064R	ROS.M10 10,5X 20X 2 U6592 ZN	WASHER M10 10,5X20X2 U6592 ZN	RONDEL. M10 10,5X20X2 U6592 ZN	SCHIBE M10 10,5X20X2 U6592 ZN	ARANDEL.M10 10,5X20X2 U6592 ZN
69	F01020476R	VITE M10X1,5X30 U5739 8.8ZN	SCR. M10X1,5X30 U5739 8.8ZN	VIS M10X1,5X30 U5739 8.8 ZN	SCHRAUBE M10X1,5X30U5739 8.8ZN	TORNIL.M10X1,5X30 U5739 8.8 ZN
70	G15355490R	GIUNTO ELASTICO D.18-22	LOCK COUPLING D.18-22	JOINT DE BLOCAGE D.18-22	SPERRKUPPLUNG D.18-22	JUNTA DE BLOQUEO D.18-22
71	F01040058R	VITE M6X1X10 U5931 8.8ZN	SCREW M6X1X10 U5931 8.8ZN	VIS M6X1X10 U5931 8.8ZN	SCHRAUBE M6X1X10 U5931 8.8ZN	TORNILLO M6X1X10 U5931 8.8ZN
72	G15355500R	RONDELLA AUTOCENTRANTE ZN	SELF-CENTERING WASHER ZN	RONDELLE AUTOCENTREE ZN	SELBSTZENTR.UNTERLEGSCH. ZN	ARANDELA AUTOCENTRADORA ZN
73	F01030038R	VITE M6X1X20 U5933 10.9ZD	SCR. M6X1X20 U5933 10.9ZD	VIS M6X1X20 U5933 10.9ZD	SCHRAU. M6X1X20 U5933 10.9ZD	TORNILLO M6X1X20 U5933 10.9ZD
74	F01030056R	VITE M8X1,25X25 U5933 10.9ZD	SCR. M8X1,25X25 U5933 10.9ZD	VIS 8X25 5933 10.9 ZN	SCHRAUBE 8X25 5933 10.9 ZN	TORNILLO 8X25 5933 10.9 ZN
75	G16050840R	ASSE D.36 X 191,5	AXLE D.36 X 191,5			
76	F02050403R	ANELLO E. DI 72X 2,5 U7437 C7	SEEGER RING E.72X2,5 U7437 C70	SEEGER E. 72X 2,5 U7437 C70	SEEGERING E. 72X 2,5 U7437 C70	ANILLO E. 72X 2,5 U7437 C70
77	F04010215R	CUSC.D30 D72 B19 6306 2RSC3 EX	BEARING D30 D72 B19 6306 2RSC3 EX	ROULEMENT	LAGER 6306 2RS C3	COJINETE 6306 2RS C3
78	F03100201R	KIT GUARN.COMPL.MOTORE DX 5,9	HYDRAULIC MOTOR SET 67007449	KIT JOINTES MOTEUR G67007449	KIT DICHT. MOTOR 67007449	SET JUNTA MOTOR 67007449

«type B»

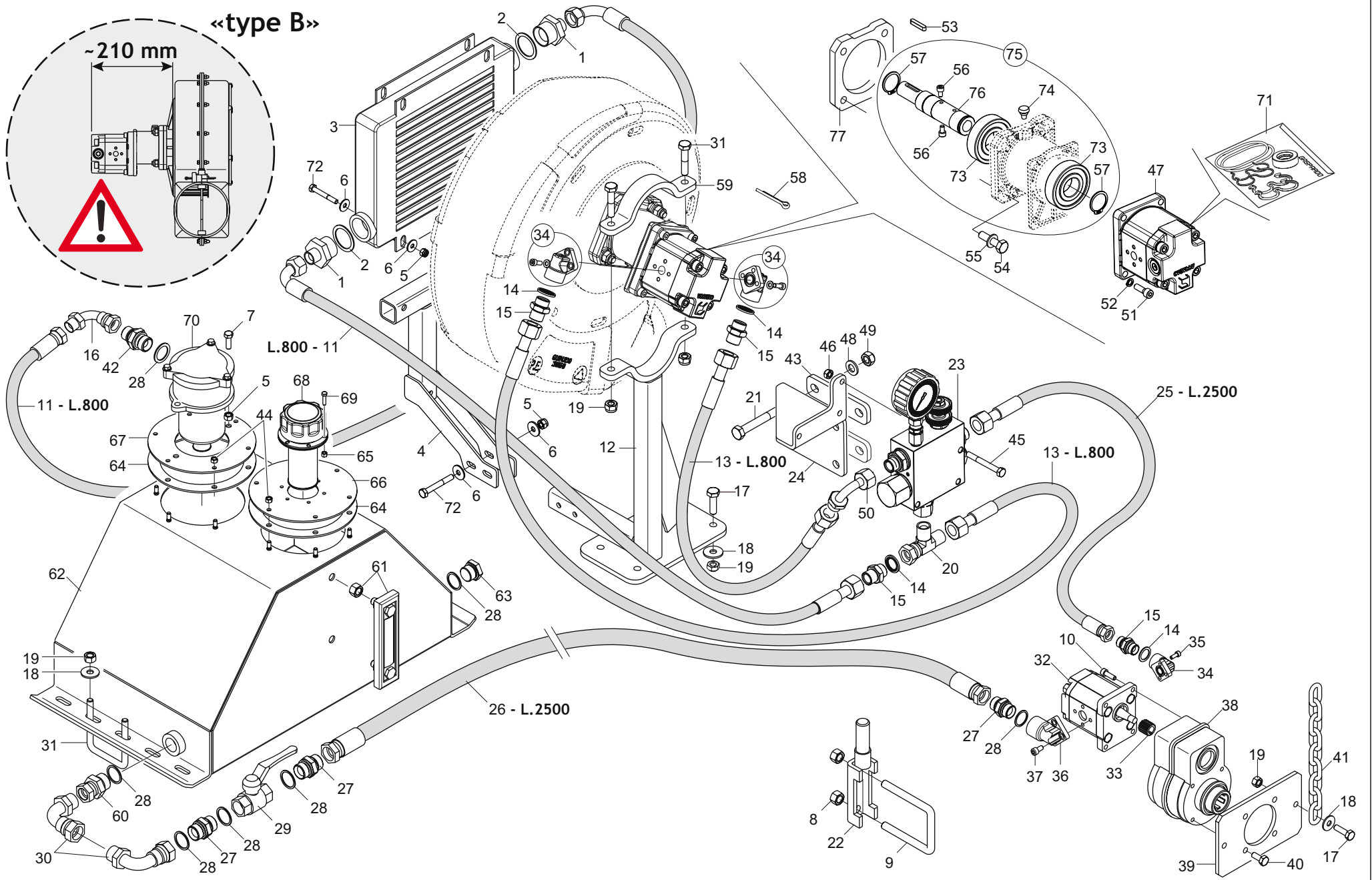
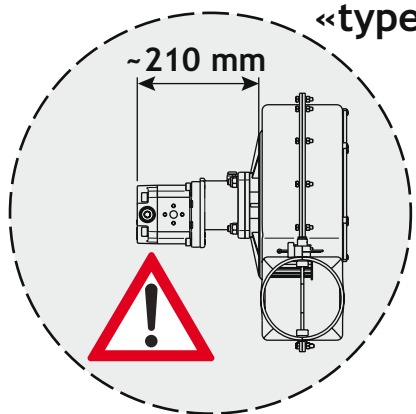

**SOFFIANTE AD AZIONAMENTO OLEODINAMICO INDIPENDENTE «TIPO B»
FAN DRIVE BY HYDRAULIC INDEPENDENT SYSTEM «TYPE B»**

TAV. 181

Pos.	Cod.	Descrizione	Description	Description	Benennung	Descripcion
1	F03150180R	NIPPLLO MASCH.CIL.1-1 2 ZN.	NIPPLE M. CYL. 1-1 2 ZN.			
2	F03151371R	RONDELLA BONDED SEAL 1 NBR	WASHER BONDED SEAL 1 NBR			
3	F03151248R	SCAMBIATORE ARIA-OLIO	AIR-OIL HEAT EXCHANGER	ECHANGEUR AIR-HUILE	AUSTAUSCHER LUFT TL	INTERCAMBIADOR AIRE-ACEITE
4	G16035320R	SUPPORTO RADIATORE	EXCHANGER SUPPORT			
5	F01230034R	DADO M8X1,25 D982 8ZN	NUT M8X1,25 D982 8ZN	ECROU M8X 1,25 D982 8 ZN	MUTTER M8X 1,25 D982 8 ZN	TUERCA M8X 1,25 D982 8 ZN
6	F01420048R	ROS.M8 8,4X 24X 2 U6593 ZN	WASHER M8 8,4X 24X2 U6593 ZN	RONDELLE M8 8,4X24X 2 U6593 ZN	SCHEIBEN M8 8,4X24X 2 U6593 ZN	ARANDELA M8 8,4X 24X2 U6593 ZN
7	F01020440R	VITE M8X1,25X25 U5739 8.8ZN	SCR. M8X1,25X25 U5739 8.8ZN	VIS M8X1,25X25 U5739 8.8 ZN	SCHRAUBE M8X1,25X25U5739 8.8ZN	TORNIL.M8X1,25X25 U5739 8.8 ZN
8	F01230073R	DADO M14X2 D982 8ZN	SELF LOCK NUT M14X2 D982 8ZN	ECROU AUTOBL.M14X2 ZN	SELBSTSP.MUTT. M14X2 D982 8ZN	TUERCA AUTOBL. M14X2 D982 8ZN
9	F20110770R	CAV.Q.B=80 M=14X2 L=119	U BOLT Q.B=80 M=14X2 L=119	BRIDE U M14X2X50 96X119 ZN	ANSCHLANGE U M14X2X50 96X119 ZN	EL.DE EMPALME M14X2X50 96X119
10	F01040095R	VITE M8X1,25X25 U5931 10.9ZD	SCR. M8X1,25X25 U5931 10.9ZD	VIS M8X1,25X25 U5931 10.9 ZD	SCHRAUB 8X25 5931 10.9	TORNILLO 8X25 5931 10.9
11	G15355630R	TUBO 1 2R2 CF1 2- F1 2 750	PIPE 1 2R2 CF1 2- F1 2 750	TUBE 1 2R2 CF1 2- F1 2 750	ROHR 1 2R2 CF1 2- F1 2 750	TUBO 1 2R2 CF1 2- F1 2 750
12	G16035281R	ASS.SUPP.VENTOLA	ASS.SUPPORT FAN			
13	G15355340R	TUBO 1 2R2 F1 2- F1 2 500	PIPE 1 2R2 F1 2- F1 2 500	TUBE 1 2R2 F1 2- F1 2 500	ROHR 1 2R2 F1 2- F1 2 500	TUBO 1 2R2 F1 2- F1 2 500
14	F03151370R	RONDELLA BONDED SEAL 1 2 NBR	WASHER BONDED SEAL 1 2 NBR			
15	F03150255R	NIPPLLO MASCH.CIL.1 2-1 2 ZN	NIPPLE M. CYL. 1 2-1 2 ZN	NIPLE M. CYL. 1 2- 1 2 ZN	NIPLE F. ZYL. 1 2-1 2 ZN	NIPLE M. CIL. 1 2- 1 2 ZN
16	F03150858R	CURVA 90 F.GIREV.1 2 - M.1 2	ELBOW 90 F.SLEWING 1 2 - M.1 2			
17	F01020479R	VITE M10X1,5X35 U5739 8.8ZN	SCR. M10X1,5X35 U5739 8.8ZN	VIS M10X1,5X35 U5739 8.8 ZN	SCHR. M10X1,5X35 U5739 8.8 ZN	TORN. M10X1,5X35 U5739 8.8 ZN
18	F01420060R	ROS.M10 10,5X 30X2,5 U6593 ZG	GALV.WASHER 10,5X30X2,5 U6593	RONDELLE 10,5X30	SCHEIBE 10,5X30	ARANDELA 10,5X30
19	F01230048R	DADO M10X1,5 D982 8ZN	NUT M10X1,5 D982 8ZN	ECR.AUTO-FREIN.M10X1,5 D982 ZN	SICHERUNGSMUTT.M10X1,5 D982 ZN	TUERCA SEGURID.M10X1,5 D982 ZN
20	F03151208R	RACCORDO L 2M1 2 F1 2 ZN	UNION L2 M1 2 F1 2 ZN	RACCORD L2 M1 2 F1 2 ZN	ANSCHLUSSTSK L2 M1 2 F1 2 ZN	UNION L2 M1 2 F1 2 ZN
21	F01020168R	VITE M12X1,75X90 U5737 8.8ZN	SCR. M12X1,75X90 U5737 8.8ZN	VIS M12X1,75X90 U5737 8.8 ZN	SCHRAB.M12X1,75X90 5737 8.8 ZN	TORNIL.M12X1,75X90 5737 8.8 ZN
22	G16019270R	SUPPORTO MOLTIPLICATORE	MULTIPLICATOR SPRING			
23	F03150540R	VALVOLA PRIORIT.MANOM.P0558086	MANOMETER PRIORITY VALVE	VANNE PRIORITAIRE MANOM TRE	PRIORIT-TSVENTIL MANOMETER	V-LVULA PRIORITARIA MAN METRO
24	G16051200R	SUPP.VALVOLA PRIORIT.	SUPPORT VALVE			
25	G15355300R	TUBO 1 2 R2 F1 2-F1 2 L.2500	PIPE 1 2 R2 F1 2-F1 2 L.2500	TUBE 1 2 R2 F1 2-F1 2 L.2500	ROHR 1 2 R2 F1 2-F1 2 L.2500	TUBO 1 2 R2 F1 2-F1 2 L.2500
26	G17930500R	TUBO 3 4R2 F3 4-F3 4 2500	PIPE 3 4R2 F3 4-F3 4 2500	TUBE 3 4R2 F3 4-F3 4 2500	ROHR 3 4R2 F3 4-F3 4 2500	TUBO 3 4R2 F3 4-F3 4 2500
27	F03020009R	NIPPLLO DI GIUNZIONE BSP 3 4-1	JUNCTION NIPPLE BSP 3 4-1	NIPPLE DE JUNCTION BSP 3 4-14	NIPPEL BSP 3 4 - 14	NIPLO DE JUNCION BSP 3 4-14
28	F03151415R	RONDELLA BONDED SEAL 3 4 NBR	WASHER BONDED SEAL 3 4 NBR			
29	F03151247R	SARACINESCA A LEVA F-F 3 4	LEVER-OPER. SLIDING VALVE 3 4	RIDEAU A LEVIER A LEVIER	HEBELFALLTSR 3 4	COMPUERTA DE PALANCA 3 4
30	F03150856R	CURVA MF 3 4-3 4 GIR. 90	ELBOW 90 F. SWIVEL 3 4 -M.3 4	COUDE 90 F.TOURN.3 4 - M.3 4	KNIESTUCK 90 F.DREHB.3 4 - M.	CURVA 90 F.GIRAT.3 4 - M.3 4C
31	F01020114R	VITE M10X1,5X50 U5737 8.8ZN	SCR. M10X1,5X50 U5737 8.8ZN	VIS M10X 1,5X50 U5737 8.8 ZN	SCHRA.M10X 1,5X50 U5737 8.8 ZN	TORN. M10X 1,5X50 U5737 8.8 ZN
32	F03151188R	POMPA AD INGR.20,8 CC 540 G.	GEAR PUMP 22L.	POMPE A ENGRANAGES 22L. 540T	ZAHNRADPUMPE 22L.	BOMBA DE ENGRANAJES 22L.
33	F03151249R	SEMIGIUNTO ALBERO CONICO POMPA	SEMI-COUPPLING PUMP TAPER-SHAFT			
34	F03151203R	KIT RACCORDO A GOMITO 1 2	1 2 ANGLED UNION	RACCORD A COUDE	WINKELANSCHLUSSTSK 1 2	CODO DE UNI N 1 2
35	F01040061R	VITE M6X1X16 U5931 8.8ZN	SCREW M6X1X16 U5931 8.8ZN	VIS M6X1X16 U5931 8.8ZN	SCHRAUBE M6X1X16 U5931 8.8ZN	TORNILLO M6X1X16 U5931 8.8ZN
36	F03151204R	KIT RACCORDO A GOMITO 3 4	3 4 ANGLED UNION	RACCORD A COUDE	WINKELANSCHLUSSTSK 3 4	CODO DE UNI N 3 4
37	F01040088R	VITE M8X1,25X16 U5931 12.9ZF	SCREW M8X1,25X16 U5931 12.9 ZF	VIS M8X1,25X16 U5931 12.9 ZF	SCHRAU.M8X1,25X16 U5931 12.9ZF	TORN. M8X1,25X16 U5931 12.9 ZF
38	F06260022R	MOLTIP.GIRI R.1 3 Z.6 540 G.	OVERDRIVE 1 3	MULTIPLICATEUR TOURS 1 3	DREHZAHLSEBSETZER 1 3	MULTIPLICADOR REVOL.1 3
39	G15355190R	ATTACCO MOLTIPLICATORE	OVERGEAR COUPLING	FIXATION MULTIPLICATEUR	KUPPLUNG SBERSETZER	CONEXI N MULTIPLICADOR
40	F01020470R	VITE M10X1,5X20 U5739 8.8ZN	SCR. M10X1,5X20 U5739 8.8ZN	VIS M10X1,5X20 U5739 8.8 ZN	SCHRAUBE M10X1,5X20 U5739 ZN	TORNILLOM10X1,5X20 U5739 8.8ZN
41	G15355400R	CATENA GENOVESE D.8 L.306 ZN	GENOAN CHAIN D.8 L.306 GALVAN	CHAINE GENOISE D.8 L.306 ZN	KETTE GENOVESE D.8 L.306 ZN	CADENA GENOVESA D.8 L.306 ZN
42	F03150244R	NIPPLLO MM CIL-CIL 1 2-3 4 ZN M	NIPLE MM CIL-CIL 1 2-3 4 ZN M	NIPLE MM CIL-CIL 1 2-3 4 ZN M	NIPLE MM CIL-CIL 1 2-3 4 ZN M	NIPLE MM CIL-CIL 1 2-3 4 ZN M
43	G15470170R	SCONTRO 35 X130 X8	STRIKER 35 X130 X8	BUTEE 35 X130 X8	ANSCHLAG 35 X130 X8	ELEMENTO DE EMPALME 35 X130 X8
44	F01230022R	DADO M6X1 D982 8ZN	NUT M6X1 D982 8ZN	ECROU AUTO-FREIN.M6X1 D982 8ZN	SICHERUNGSMUT. M6X1 D982 8 ZN	TUERCA DE SEGU.M6X1 D982 8 ZN
45	F01020083R	VITE M8X1,25X70 U5737 8.8ZN	SCR. M8X1,25X70 U5737 8.8ZN	VIS M 8X1,25X 70 U5737 8.8 ZN	SCHRA. M8X1,25X70 U5737 8.8ZN	TORN. M 8X1,25X 70 U5737 8.8ZN
46	F01220022R	DADO M8X1,25 D980 8ZN	NUT M8X1,25 D980 8ZN	ECROU M8X 1,25 D980 8 ZN	MUTTER M8X 1,25 D980 8 ZN	TUERCA M8X 1,25 D980 8 ZN
47	F03150998R	MOTORE PLM 20,8 DX ANTICAV.	MOTOR PLM 20,8 DX ANTICAV			
48	F01410076R	ROS.M12 13X 24X2,5 U6592 ZN	WASHER 12 13X 24X2,5 U6592 ZN	RONDEL. M12 13X24X2,5 U6592 ZN	SCHEIBE M12 13X24X2,5 U6592 ZN	ARANDELA M12 13 X24X2,5 ZN
49	F01220048R	DADO M12X1,75 D980 8ZN	NUT M12X1,75 D980 8ZN	ECROU M12X1,75 D980 8 ZN	SCHEIBE M12X1,75 D980 8 ZN	TUERCA M12X1,75 D980 8 ZN
50	F03150858R	CURVA 90 F.GIREV.1 2 - M.1 2	ELBOW 90 F.SLEWING 1 2 - M.1 2			
51	F01040601R	VITE M8X1,25X25 U5931 8.8ZD	SCR. M8X1,25X25 U5931 8.8ZD	VIS M8 X1,25X25 U5931 8.8 ZD	SCHRAUBE M8X1,25X25U5931 8.8ZD	TORNILLO M8X1,25X25U5931 8.8ZD
52	F01480033R	ROS.G 8,1X 12,7X 2 D7980 ZN	GROVER WASHER D8,1X12,7D7980ZN	ROND.ELASTIQ D8,1X12,7 D7980ZN	FEDERRINGE D8,1X12,7 D7980 ZN	ARAND.ELICOI.D8,1X12,7 D7980ZN
53	F02150038R	LINGUETTA 6X 6X 30 U6604A	PARALLEL KEY 6X 6X 30 U6604A	LANGUETTE 06X6X30 UNI6604	FEDERKEIL 06X6X30 UNI6604	LENGSETA 06X6X30 UNI6604
54	F01020483R	VITE M10X1,5X40 U5739 10.9ZD	SCR. M10X1,5X40 U5739 10.9ZD	VIS M10X1,5X40 U5739 10.9 ZD	SCHRA.M10X1,5X40 U5739 10.9 ZD	TORN. M10X1,5X40 U5739 10.9 ZD
55	F01410064R	ROS.M10 10,5X 20X 2 U6592 ZN	WASHER M10 10,5X20X2 U6592 ZN	RONDEL. M10 10,5X20X2 U6592 ZN	SCHEIBE M10 10,5X20X2 U6592 ZN	ARANDEL.M10 10,5X20X2 U6592 ZN

«type B»

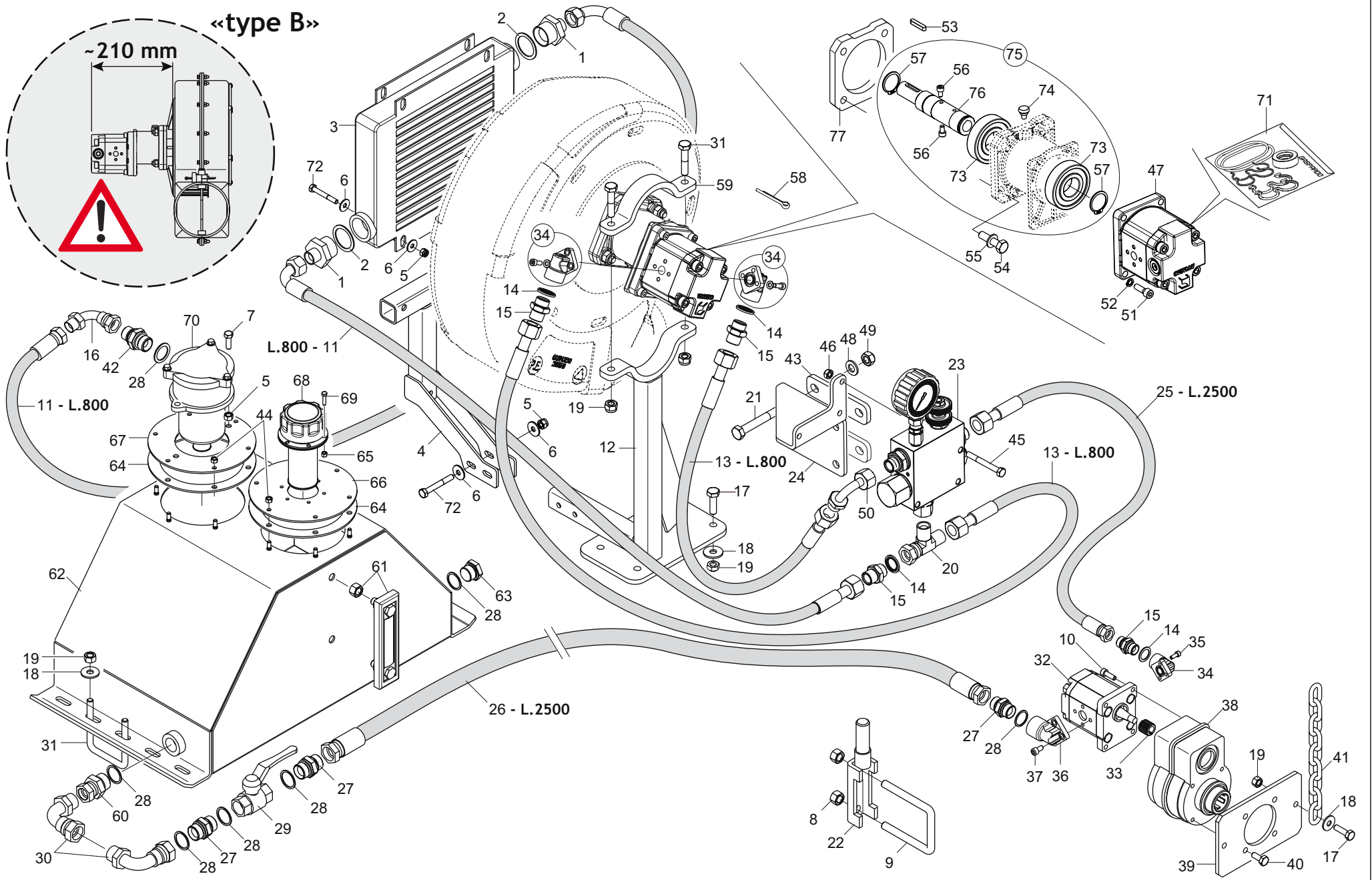
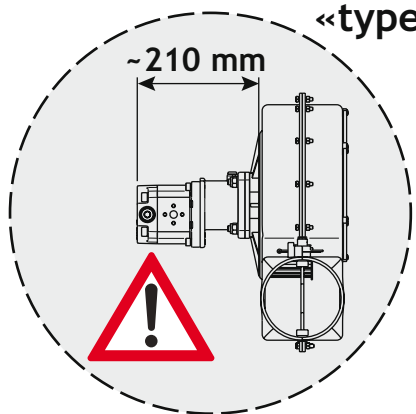

**SOFFIANTE AD AZIONAMENTO OLEODINAMICO INDIPENDENTE «TIPO B»
FAN DRIVE BY HYDRAULIC INDEPENDENT SYSTEM «TYPE B»**

TAV. 181

Pos.	Cod.	Descrizione	Description	Description	Benennung	Descripcion
56	F01040058R	VITE M6X1X10 U5931 8.8ZN	SCREW M6X1X10 U5931 8.8ZN	VIS M6X1X10 U5931 8.8ZN	SCHRAUBE M6X1X10 U5931 8.8ZN	TORNILLO M6X1X10 U5931 8.8ZN
57	F02050112R	ANELLO E.DE 30X 1,5 U7435 ZN	SEEGER RING 30X 1,5 U7435 C70	SEEGER E. 30 X 1,5 U7435 C70	SEEGERING E. 30X 1,5 U7435 C70	ANILLO E. 30 X 1,5 U7435 C70
58	F02200199R	COPIGLIA 4X65 U1336 ZN	SPLIT PIN 4 X65 1336 GALVAN.	GOUPILLE 4 X65 1336 ZN	SPLINT 4 X65 1336 ZN	PASADOR 4 X65 1336 ZN
59	G16051120R	CHIUSURA SUP.L30	CLOSURE SUP.L30			
60	F03150078R	NIPPLO MF GIREVOLE 3 4 ZG CIL	NIPPLE M-F SWIVEL 3 4 ZINC.	NIPPLE M-F TOURNANT 3 4 ZING.	NIPPEL M-F DREHBAR 3 4 VERZINK	NIPLE M-H GIRATORIO 3 4 CINC.
61	F03151161R	LIVELLO OLIO CON TERMOMETRO	OIL LEVEL WITH THERMOMETER	NIVEAU HUILE AVEC THERMOMETRE	LSTAND MIT THERMOMETER	NIVEL ACEITE CON TERMOMETRO
62	G16070600R	SERBATOIO OLIO L.48	OIL TANK L.48			
63	F03150720R	TAPPO MASCHIO 3 4 GAS	PLUG 3 4	BOUCHON	PFROPFEN 3 4	TAP N 3 4
64	G15355720R	GUARNIZIONE IMP.OLEOD.	GASKET FOR HYDR.SYST.			
65	F01230019R	DADO M5X0,8 D982 8ZN	NUT M5X0,8 D982 8ZN	ECROU AUTOB.NOR.5 ZN	SELBSTSP. MUTTER NOR.5 ZN	TUERCA AUTOB. NOR. 5 ZN
66	G15355700R	SUPPORTO TAPPO CAR.OLIO ZN	CLOSURE TAP SUPPORT	SUPPORT BOUCHON DE FERMETURE	HALTERUNG ABSCHLUSSPFROPFEN	SOPORTE TAPON DE CIERRE
67	G15355710R	SUPPORTO FILTRO OLIO DP ZN	CLOSURE FILTER	SUPPORT FILTRE	HALTERUNG FILTER	SOPORTE FILTRO
68	F03150716R	TAPPO DI CARICAMENTO OLIO	INLET OIL PLUG	BOUCHON HUILE	TLSCHRAUBE	TAP N ACEITE
69	F01020380R	VITE M5X0,8X20 U5739 8.8ZN	SCR. M5X0,8X20 U5739 8.8ZN	VIS M5X0,8X20 U5739 8.8ZN	SCHRAUBE M5X0,8X20 U5739 8.8ZN	TORNILLO M5X0,8X20 U5739 8.8ZN
70	F03151147R	FILTRO	FILTER	FILTRE	FILTER	FILTRO
71	F03100224R	KIT GUAR.MOTORE DX20,8ANTICAV.	KIT O-RING ENGINE DX20,8			
72	F01020077R	VITE M8X1,25X60 U5737 8.8ZN	SCR. M8X1,25X60 U5737 8.8ZN	VIS M8X1,25X60 U5737 8.8ZN	SCHRAU. M8X1,25X60 U5737 8.8ZN	TORN. M8X1,25X60 U5737 8.8 ZN
73	F04010215R	CUSC.D30 D72 B19 6306 2RSC3 EX	BEARING D30 D72 B19 6306 2RSC3 EX	ROULEMENT	LAGER 6306 2RS C3	COJINETE 6306 2RS C3
74	G66248223R	TAPPO SUPP.SPAND.D.11	PLUG MAN. SPR. SUPP. D.11	BOUCHON SUPPORT EP. ENGRAIS D.	HALTERUNGSPROPFEN DSNGERSTR.	TAP N SOPORTE ABON.D.11
75	GA5250140R	MONT.MOZZO CUSC.ALB.D.22	ASS.HUB BEARING SHAFT D.22			
76	GA5250120R	ALBERO VENTOLA D.22	SHAFT FAN D.22			
77	GA5250100R	FLANGIA 115X115X12 D.85	FLANGE 115X115X12 D.85			

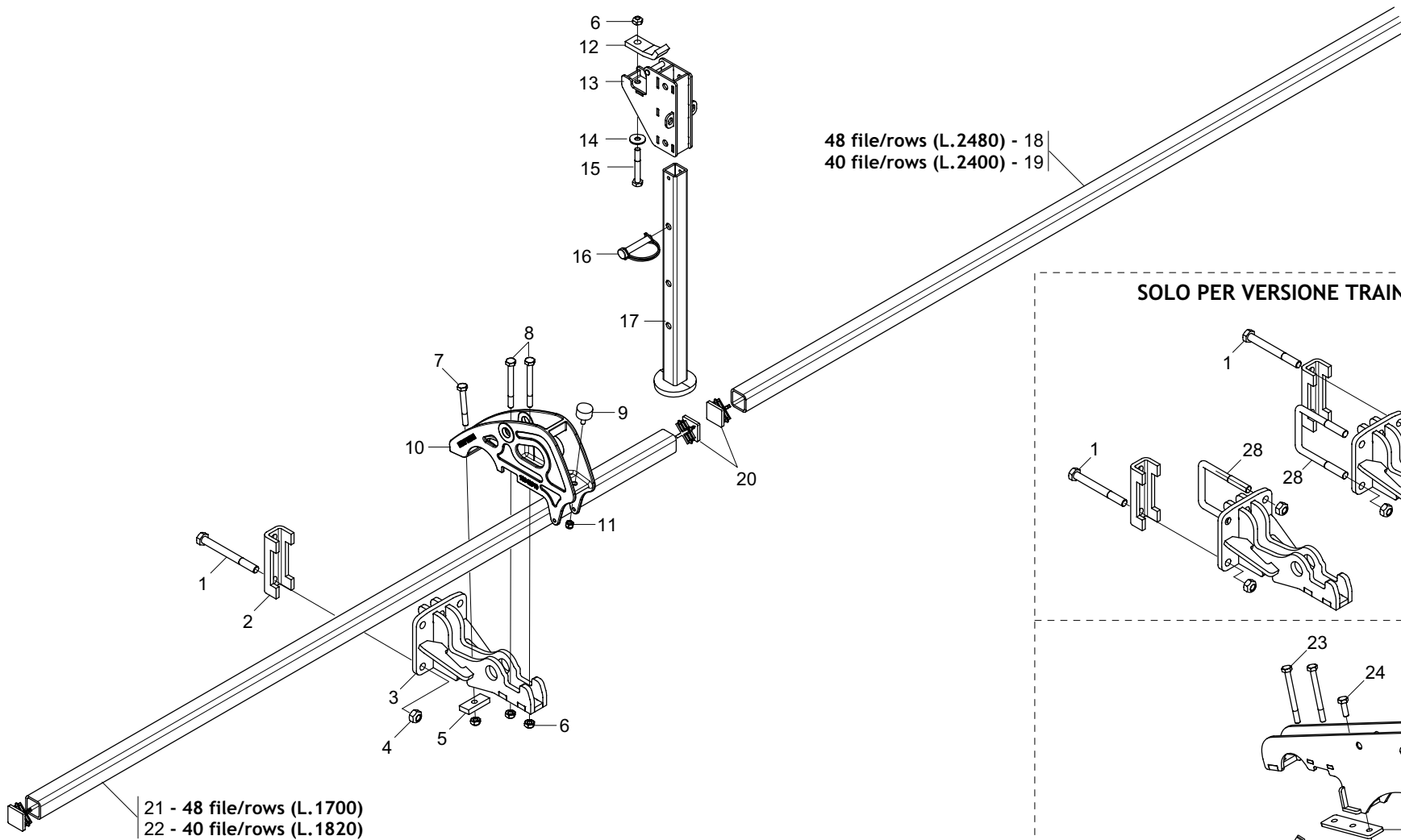

SOLO PER VERSIONE TRAINATA

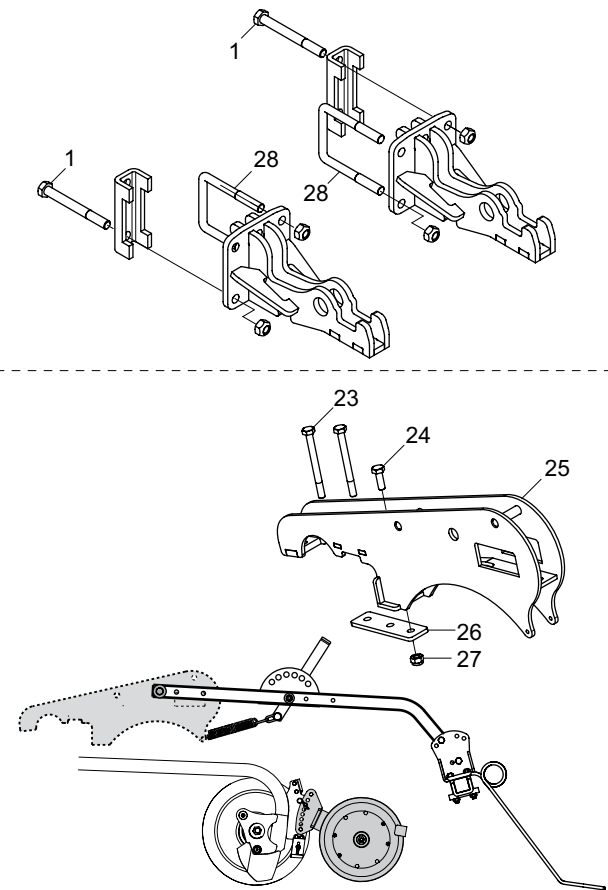

**TELAIO BARRA ASSOLCATORI
FRAME TO COULTERS BAR**

TAV. 190

Pos.	Cod.	Descrizione	Description	Description	Benennung	Descripcion
1	F01020221R	VITE M14X2X140 U5737 8.8BR	SCR. M14X2X140 U5737 8.8BR	VIS M 14 X140 5737 8.G	SCHRAUBE M 14 X140 5737 8.G	TORNILLO M 14 X140 5737 8.G
2	G36200241R	SCONTRO U 80	FLANGE U 80	BRIDE U 80	ANSCHLAG U 80	ELEMENTO DE EMPALME U 80
3	G16075060R	SUPPORTO BARRA DI SEMINA	SEED SUPPORT BAR			
4	F01220255R	DADO M14X2 D980 8ZN	NUT M14X2 D980 8ZN	ECROU M14X2 D980 8 ZN	MUTTER M14X2 D980 8 ZN	TUERCA M14X2 D980 8 ZN
5	G16071640R	PIASTRINA DI ANCORAGGIO ZN	ANCHORING PLATE			
6	F01220033R	DADO M10X1,5 D980 8ZN	NUT M10X1,5 D980 8ZN	ECROU M10X1,5 D980 8ZN	MUTTER M10X1,5 D980 8ZN	TUERCA M10X1,5 D980 8ZN
7	F01020128R	VITE M10X1,5X80 U5737 8.8ZN	SCR. M10X1,5X80 U5737 8.8ZN	VIS M10X1,5X80 U5737 8.8 ZN	SCHRAU. M10X1,5X80 U5737 8.8ZN	TORNIL.M10X1,5X80 U5737 8.8 ZN
8	F01020133R	VITE M10X1,5X100 U5737 8.8ZN	SCR. M10X1,5X100 U5737 8.8ZN	VIS M10X1,5 X100 U5737 8.8ZN	SCHRAU.M10X1,5X100 U5737 8.8ZN	TORNI. M10X1,5X100 U5737 8.8ZN
9	F05150456R	PARACOLPI 30X15 M8X25	BUFFER 30X15 M8X25	PARE-CHOCS 30X15 M8X25	STOSSDZMPFER 30X15 M8X25	PARAGOLPES 30X15 M8X25
10	G16043510R	SUPP.BRACCIO ERPICE COPRISEME	ARM SUPP.SEEDCOVER HARROW			
11	F01230034R	DADO M8X1,25 D982 8ZN	NUT M8X1,25 D982 8ZN	ECROU M8X 1,25 ZN	MUTTER M8X 1,25 D982 8 ZN	TUERCA M8X 1,25 D982 8 ZN
12	G16015981R	SCONTRO DI FISSAGGIO ZN	SECURING STOP TEETH	BUTEE DE FIXATION	FESTANSCHLAG	DIENTE DE PARADA DE FIJACI N
13	G16041472R	ASS.SUPPORTO PUNTELLO	ASS.PROP SUPPORT			
14	F01420060R	ROS.M10 10,5X 30X2,5 U6593 ZG	GALV.WASHER 10,5X30X2,5 U6593	RONDELLE 10,5X30	SCHEIBE 10,5X30	ARANDELA 10,5X30
15	F01020125R	VITE M10X1,5X75 U5737 8.8ZN	SCR. M10X1,5X75 U5737 8.8ZN	VIS M10X1,5X75 U5737 8.8ZN	SCHRAU. M10X1,5X75 U5737 8.8ZN	TORN. M10X1,5X75 U5737 8.8ZN
16	F02200584R	SPINA SICUR.D.12X70 ZN	PIN D12 L70 ZN	FICHE D12 L70 ZN	STIFT D12 L70 ZN	CLAVIJA D12 L70 ZN
17	G15112691R	PUNTELLO ST250	PROP ST250			
18	G16340170R	TUBO Q. 40X 4X2480	TUBE Q. 40X 4X2480			
19	G13723060R	TUBO SUPP.SERBATOIO HS L.2400	TANK SUPP. TUBE L.2400	TUBE SUPP. RESERVOIRS L.2400	ROHR BEHZLTERHALTERUNG L.2400	TUBO SOP.DEPSITOS L.2400
20	F20120348R	PUNTALE Q.40 NERO	SQUARE TIP 40 BLACK			
21	G17916490R	TUBO Q.40X4X1700	SQUARE TUBE 40X4X1700			
22	G17914960R	TUBO Q.40X4X1820	SQUARE TUBE 40X4X1820			
23	F01020135R	VITE M10X1,5X110 U5737 8.8ZN	SCR. M10X1,5X110 U5737 8.8ZN	VIS M 10X110	SCHRAUBE M 10X110	TORNILLO M 10X110
24	F01020476R	VITE M10X1,5X30 U5739 8.8ZN	SCR. M10X1,5X30 U5739 8.8ZN	VIS M10X1,5X30 U5739 8.8 ZN	SCHRAUBE M10X1,5X30U5739 8.8ZN	TORNIL.M10X1,5X30 U5739 8.8 ZN
25	G16074370R	SUPPORTO BRACCIO ERPICE	HARROW ARM SUPPORT			
26	G16074580R	SCONTRO 135X 40- 6 3F11 51-46	PLATE135X40-6 3HOLES11 51-46			
27	F01230048R	DADO M10X1,5 D982 8ZN	NUT M10X1,5 D982 8ZN	ECR.AUTO-FREIN.M10X1,5 D982 ZN	SICHERUNGSMUTT.M10X1,5 D982 ZN	TUERCA SEGURID.M10X1,5 D982 ZN
28	F20110770R	CAV.Q.B=80 M=14X2 L=119	U BOLT Q.B=80 M=14X2 L=119	BRIDE U M14X2X50 96X119 ZN	ANSCHLANG U M14X2X50 96X119 ZN	EL.DE EMPALME M14X2X50 96X119

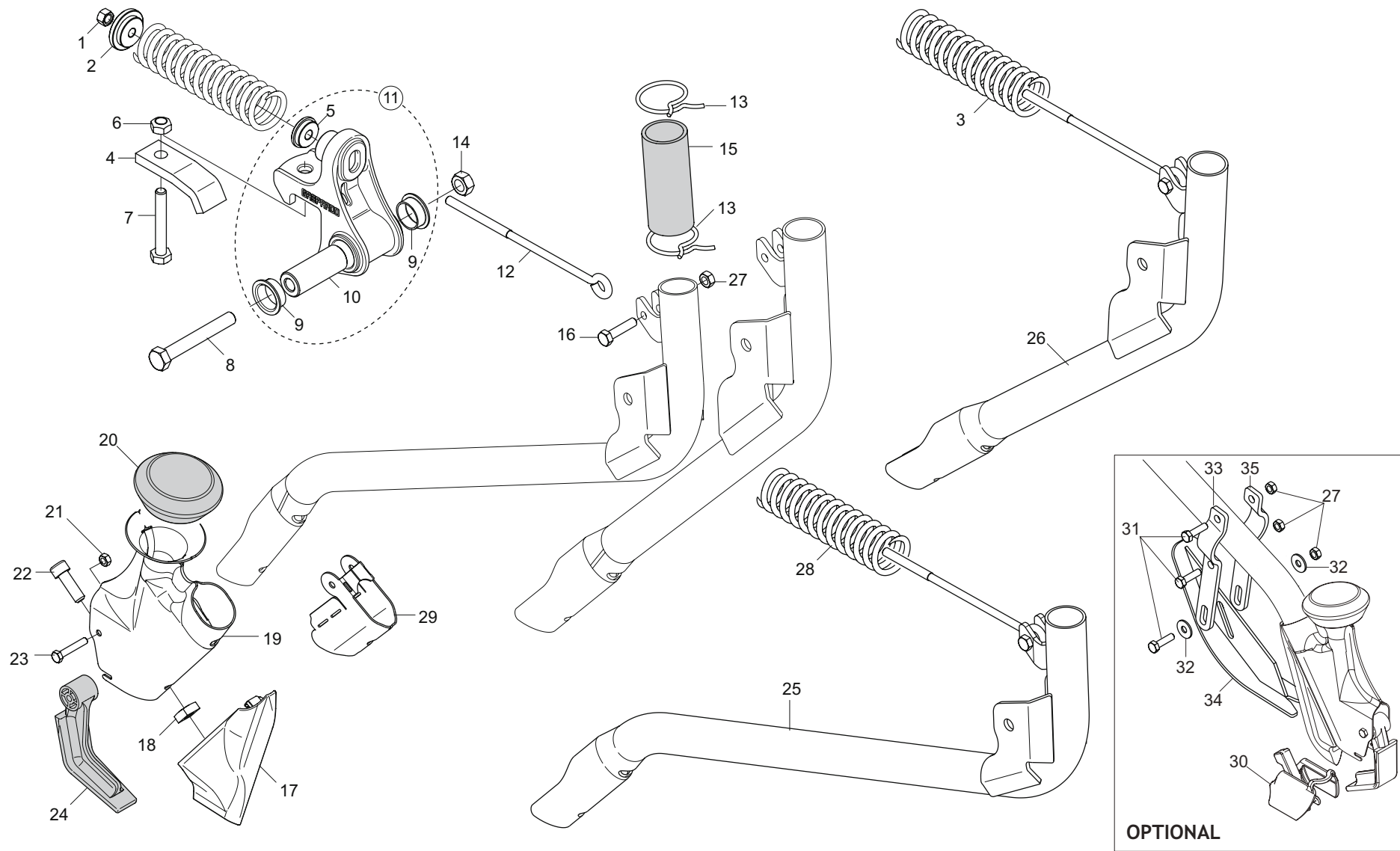

ASSOLCATORI A STIVALETTO SHOE COULTERS

TAV. 200

Pos.	Cod.	Descrizione	Description	Description	Benennung	Descripcion
1	F01230034R	DADO M8X1,25 D982 8ZN	NUT M8X1,25 D982 8ZN	ECROU M8X 1,25 ZN	MUTTER M8X 1,25 D982 8 ZN	TUERCA M8X 1,25 D982 8 ZN
2	G16041260R	FONDELLO ZN	BOTTOM GALV.ED			
3	G18904420R	MOLLA TENS.ASSOLCAT.CORTO ZN	SPRING TENSION FURROW SHORT			
4	G16015981R	SCONTRO DI FISSAGGIO ZN	SECURING STOP TEETH	BUTEE DE FIXATION	FESTANSCHLAG	DIENTE DE PARADA DE FIJACI N
5	G19006510R	BOCCOLA GUIDA TIRANTE	BUSHING TIE-ROD GUIDE			
6	F01220033R	DADO M10X1,5 D980 8ZN	NUT M10X1,5 D980 8ZN	ECROU M10X1,5 D980 8ZN	MUTTER M10X1,5 D980 8ZN	TUERCA M10X1,5 D980 8ZN
7	F01020125R	VITE M10X1,5X75 U5737 8.8ZN	SCR. M10X1,5X75 U5737 8.8ZN	VIS M10X1,5X75 U5737 8.8ZN	SCHRAU. M10X1,5X78 U5737 8.8ZN	TORN. M10X1,5X75 U5737 8.8ZN
8	F01020168R	VITE M12X1,75X90 U5737 8.8ZN	SCR. M12X1,75X90 U5737 8.8ZN	VIS M12X1,75X90 U5737 8.8ZN	SCHRAB.M12X1,75X90 5737 8.8 ZN	TORNIL.M12X1,75X90 5737 8.8 ZN
9	F04150034R	CUSCINETTO FLANGIATO 25X28X16	BEARING FLANGED 25X28X16			
10	G18802740R	BOCCOLA 25X12X63,5	BUSHING 25X12X63,5	BOITE 25X12X63,5	BUCHSE 25X12X63,5	CASQUILLO 25X12X63,5
11	G16043680R	SUPPORTO ASSOLCATORE COMPL.	FURROW SUPPORT COMPL.			
12	G16041251R	TIRANTE	TIE ROD			
13	G65336001R	MOLLA SPEC.ZN STRING.CONC. SP	SPEC SPRING ZN MAN. PIPE CLAMP	RESSORT SPEC. ZN SERRE-TUBE LO	SPEZIALFEDER ZN DSNNGERSHELLE.	MUELLE ESPEC. ZN APLASTA ABONO
14	F01220048R	DADO M12X1,75 D980 8ZN	NUT M12X1,75 D980 8ZN	ECROU M12X1,75 D980 8 ZN	SCHEIBE M12X1,75 D980 8 ZN	TUERCA M12X1,75 D980 8 ZN
15	G19005340R	MANICOTTO DI GIUNZIONE	JOINT SLEEVE	MANCHON DE RACCORD	VERBINDUNGSMUFFE	MANGUITO DE UNIN
16	F01020063R	VITE M8X1,25X35 U5737 8.8ZN	SCR. M8X1,25X35 U5737 8.8ZN	VIS M8X1,25X35 U5737 8.8ZN	SCHRAU. M8X1,25X35 U5737 8.8ZN	TORN. M8X1,25X35 U5737 8.8ZN
17	G16243960R	FALCIONE SCARP.TAGLIENTE	SUFFOLK KNIFE COULTER	COUPEUR TRANCHANTE		BOTA
18	F01270010R	DADO M10X1,5 D557 17X8 ZN	NUT M10X1,5 D557 17X8 ZN	ECROU M10X1,5 D557 17X8 Z	MUTTER M10X1,5 D557 17X8	TUERCA M10X1,5 D557 17X8
19	G16243990R	SCARPETTA INTERCAMBIABILE	INTERCHANGE CUTTER	HACHOIR	SAASCHAR	HOJA DE CORTE
20	G19003270R	CUFFIA TUBO SCARPETTA	SLIDE PIPE HOUSING	BOUCHON TUBE SABOT	KASTEN ROHR SCHUH	ENVOLTURA TUBO GU A APOYO
21	F01220011R	DADO M6X1 D980 8ZN	NUT M6X1 D980 8ZN	ECROU M6X1 D980 8 ZN	MUTTER M6X1 D980 8 ZN	TUERCA M6X1 D980 8 ZN
22	F01040600R	VITE M10X1,5X30 U9327 8.8ZN	SCR. M10X1,5X30 U9327 8.8ZN	VIS M10X 30 U9327 8.8 ZN	SCHRAUBE M10X 30 U9327 8.8 ZN	TORNILLO M10X 30 U9327 8.8 ZN
23	F01020411R	VITE M6X1X35 U5739 8.8ZN	SCR. M6X1X35 U5739 8.8ZN	VIS M6X1X35 U5739 8.8ZN	SCHRAUBE M6X1X35 U5739 8.8ZN	TORNILLO M6X1X35 U5739 8.8ZN
24	G07002218R	ANTI INTASAMENTO M	ANTI CLOGGING M	ANTI BOURRAGE SOC	VERSTOPFUNGSHEMMENDES ELEMENT	ANTI OBSTRUCCI N M
25	G16041692R	TUBO LUNGO E TIRANTE COMPL	LONG TUBE-TIE ROD ASS.BLY			
26	G16041672R	TUBO CORTO E TIRANTE COMPL	SHORT TUBE AND TIE ROD			
27	F01220022R	DADO M8X1,25 D980 8ZN	NUT M8X1,25 D980 8ZN	ECROU M8X 1,25 D980 8 ZN	MUTTER M8X 1,25 D980 8 ZN	TUERCA M8X 1,25 D980 8 ZN
28	G18904631R	MOLLA TENS.ASSOLCAT.LUNGO ZN	SPRING TENSION FURROW LONG			
29	G16044310R	SCARPETTA GUIDA SEME	SEED GUIDE RUNNER			
30	G16243770R	SCARPA SEMINA A FASCIA	BANDS CUTTER	HACHOIR BANDES	SZSCHAR BANDEL	GUA ADORA FAJA
31	F01020445R	VITE M8X1,25X30 U5739 8.8ZN	SCR. M8X1,25X30 U5739 8.8ZN	VIS M 8X1,25X30 U5739 8.8 ZN	SCHRAU, M8X1,25X30 U5739 8.8ZN	TORN. M8X1,25X30 U5739 8.8 ZN
32	F01420048R	ROS.M8 8,4X 24X 2 U6593 ZN	WASHER M8 8,4X 24X2 U6593 ZN	RONDELLE M8 8,4X24X 2 U6593 ZN	SCHEIBEN M8 8,4X24X 2 U6593 ZN	ARANDELA M8 8,4X 24X2 U6593 ZN
33	G16249010R	SUPPORTO SX PATTINO LIMITATORE	LEFT SUPPORT LIMITER SLIDING			
34	G16248980R	PATTINO LIMITATORE	LIMITER SLIDING			
35	G16249000R	SUPPORTO DX PATTINO LIMITATORE	RIGT SUPP.LIMITER SLIDING			

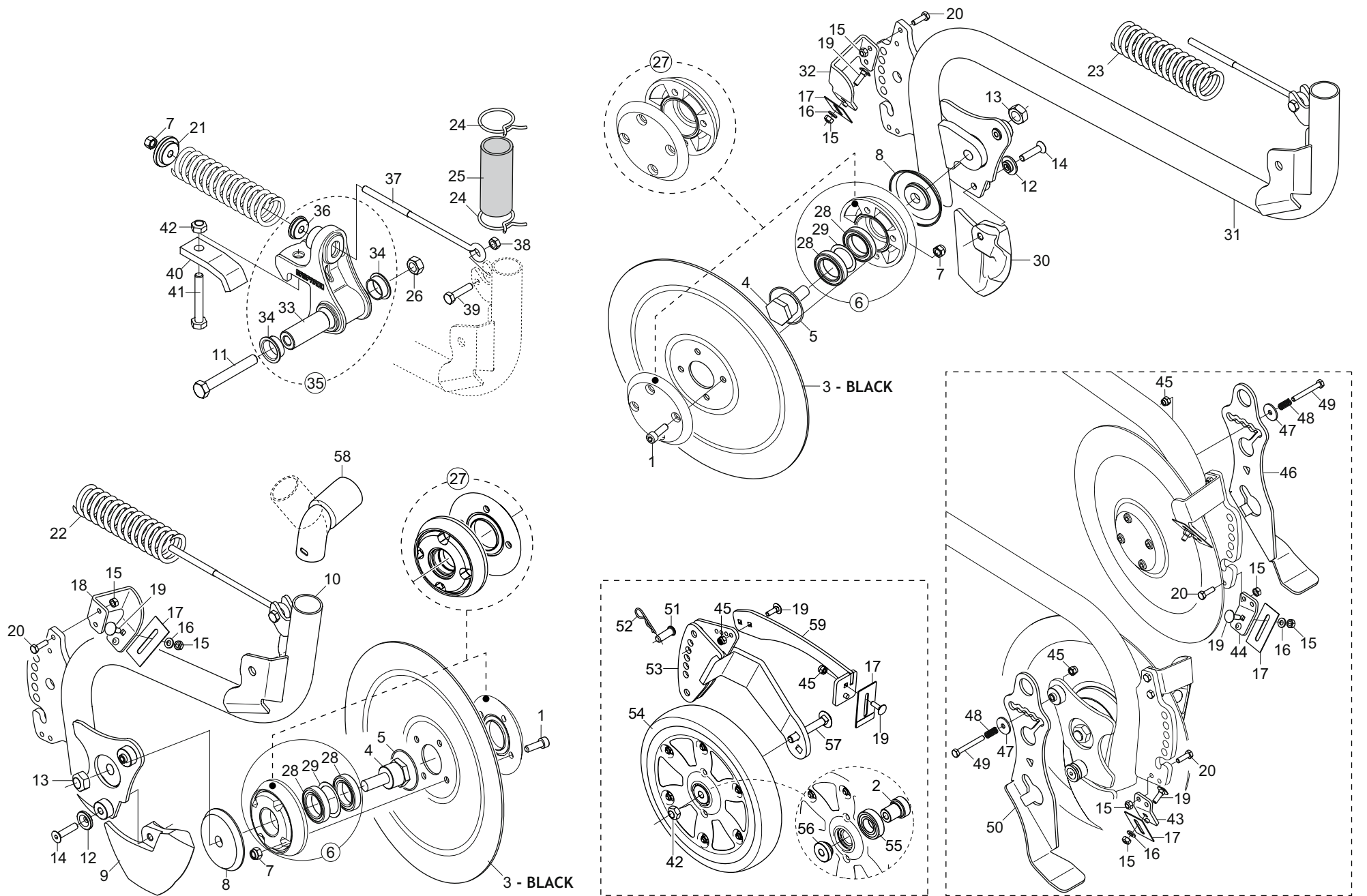

ASSOLCATORI A DISCO SEMPLICE SINGLE DISC COULTERS

TAV. 210

Pos.	Cod.	Descrizione	Description	Description	Benennung	Descripcion
1	F01040501R	VITE M8X1,25X25 D7984 8.8ZN	SCREW M8X1,25X25 D7984 8.8ZN	VIS M8X1,25X25 D7984 8.8ZN	SCHRAU. M8X1,25X25 D7984 8.8ZN	TORN. M8X1,25X25 D7984 8.8ZN
2	G16043820R	BOCCOLA D10XD29-35 ZN	BUSHING D10XD29-35 ZN			
3	G16043890R	DISCO ASSOLCATORE D.328 SP.2,5	DISC OPENER D.328 SP.2,5	DISCO ASSOLCATORE D.328 SP2,5		DISCO SURGADOR D.328 SP 2,5
4	G16040820R	ASSE DISCO	DISC SPINDLE	AXE DISQUE	SCHEIBENACHSE	EJE DISCO
5	F03010576R	ANELLO OR 50,52X1,78 NBR	GASKET OR 50,52X1,78 NBR	BAGUE OR 50,52X1,78 NBR	RING OR 50,52X1,78 NBR	ANILLO OR 50,52X1,78 NBR
6	G16040921R	FLANGIA CON CUSCINETTI	FLANGE W BEARING	BRIDE AVEC ROULEMENTS	FLANSCH MIT LAGERN	BRIDA CON COJINETES
7	F01230034R	DADO M8X1,25 D982 8ZN	NUT M8X1,25 D982 8ZN	ECROU M8X 1,25 ZN	MUTTER M8X 1,25 D982 8 ZN	TUERCA M8X 1,25 D982 8 ZN
8	G16040863R	PARAPOLVERE DI BLOCCAGGIO ZAMA	ZAMA LOCK DUST SEAL	PARE-POUSSI RE DE BLOCAGE ZAMA	FESTSTELL-STAUBABDECKUNG ZAMA	GUARDAPOLVO DE BLOQUEO ZAMAK
9	G19203980R	FALCIONE DS DX	RIGHT CUTTER	COUTEUR DX		BOTA DS DER
10	G16043691R	TUBO CORTO E TIRANTE	SHORT TUBE & TIGHTENER			
11	F01020168R	VITE M12X1,75X90 U5737 8.8ZN	SCR. M12X1,75X90 U5737 8.8ZN	VIS M12X1,75X90 U5737 8.8 ZN	SCHRAB.M12X1,75X90 5737 8.8 ZN	TORNIL.M12X1,75X90 5737 8.8 ZN
12	F15821110R	BOCCOLA SUPPORTO COPRISEME	SEED COVER SUPP. BUSHING	BOITE SUPPORT COUVRE-SEMENCE	BSCHSE SAMENABDECKERHALTER.	CASQUILLO SOPORTE CUBRESEMILLA
13	F01220255R	DADO M14X2 D980 8ZN	NUT M14X2 D980 8ZN	ECROU M14X2 D980 8 ZN	MUTTER M14X2 D980 8 ZN	TUERCA M14X2 D980 8 ZN
14	F01030060R	VITE M8X1,25X35 U5933 10.9ZD	SCREW M8X1,25X35 U5933 10.9ZD	VIS M8X1,25X35 U5933 10.9ZD	SCHRA.M8X1,25X35 U5933 10.9ZD	TORN. M8X1,25X35 U5933 10.9ZD
15	F01220011R	DADO M6X1 D980 8ZN	NUT M6X1 D980 8ZN	ECROU M6X1 D980 8 ZN	MUTTER M6X1 D980 8 ZN	TUERCA M6X1 D980 8 ZN
16	F01410037R	ROS.M6 6.4X12,5X1,6 U6592 ZN	WASHER M6 6.4X12,5X1,6 U6592ZN	RONDEL.M6 6,4X12,5X1,6 U6592ZN	SCHEIB.M6 6,4X12,5X1,6 U6592ZN	ARAND.M6 6,4X12,5X1,6 U6592 ZN
17	G16043880R	RASCHIATERRA DS CON RIPORTO ZN	SOILSCRAPER DS ZN	CROTTOIR DS AVEC REPORT		
18	G16043730R	ASS.SUPP.SUP.RASCHIATERRA SX	ASS.SUPP.L.SOILSCRAPER			
19	F01060013R	VITE M6X1X20 U5731 8.8ZN	SCR. M6X1X20 U5732 4.6ZN	VIS 6X20 5732 4.6 ZN	SCHRAUBE 6X20 5732 4.6 ZN	TORNILLO 6X20 5732 4.6 ZN
20	F01020404R	VITE M6X1X20 U5739 8.8ZN	SCREW M6X1X20 U5739 8.8ZN	VIS M6X1X20 U5739 8.8ZN	SCHRAUBE M6X1X20 U5739 8.8ZN	TORNILLO M6X1X20 U5739 8.8ZN
21	G16041260R	FONDELLO ZN	BOTTOM GALV.ED			
22	G18904420R	MOLLA TENS.ASSOLCAT.CORTO ZN	SPRING TENSION FURROW SHORT			
23	G18904631R	MOLLA TENS.ASSOLCAT.LUNGO ZN	SPRING TENSION FURROW LONG			
24	G65336001R	MOLLA SPEC.ZN STRING.CONC. SP	SPEC SPRING ZN MAN. PIPE CLAMP	RESSORT SPEC. ZN SERRE-TUBE LO	SPEZIALFEDER ZN DSNNGERSCHELLE.	MUELLE ESPEC. ZN APLASTA ABONO
25	G19005340R	MANICOTTO DI GIUNZIONE	JOINT SLEEVE	MANCHON DE RACCORD	VERBINDUNGSMUFFE	MANGUITO DE UNIN
26	F01220048R	DADO M12X1,75 D980 8ZN	NUT M12X1,75 D980 8ZN	ECROU M12X1,75 D980 8 ZN	SCHEIBE M12X1,75 D980 8 ZN	TUERCA M12X1,75 D980 8 ZN
27	G19003422R	KIT FLANGIA CUSC. DISCO EST.	KIT BEARING FLANGE OUTER DISC	BRIDE PORTE-ROULEMENTS	LAGERTR-GERFLANSCH	BRIDA PORTACOJINETES
28	F04010309R	CUSC.D30 D47 B9 61906 LLU	BEARING D30 D47 B9 61906 2RS	PALIER 61906-2RS	LAGER 61906-2RS	COJINETE 61906-2RS
29	F01440081R	ROS. 37X47X0,1 D988 ST2K60 BR	RAISING WASHER 37X47X0.1	RONDELLE D EPAISSEUR 37X47X0,1	AUSGLEICHSSCHEIBE 37X47X0,1	ARANDELA DE APOYO 37X47X0,1
30	G19203970R	FALCIONE DS SX	LEFT CUTTER	COUTEUR GX		BOTA DS IZQ
31	G16043701R	TUBO LUNGO E TIRANTE	LONG TUBE & TIGHTENER			
32	G16043720R	ASS.SUPP.SUP.RASCHIATERRA DX	ASS.SUPP.R.SOILSCRAPER			
33	G18802740R	BOCCOLA 25X12X63,5	BUSHING 25X12X63,5	BOITE 25X12X63,5	BUCHSE 25X12X63,5	CASQUILLO 25X12X63,5
34	F04150034R	CUSCINETTO FLANGIATO 25X28X16	BEARING FLANGED 25X28X16			
35	G16043680R	SUPPORTO ASSOLCATORE COMPL.	FURROW SUPPORT COMPL.			
36	G19006510R	BOCCOLA GUIDA TIRANTE	BUSHING TIE-ROD GUIDE			
37	G16041251R	TIRANTE	TIE ROD			
38	F01220022R	DADO M8X1,25 D980 8ZN	NUT M8X1,25 D980 8ZN	ECROU M8X 1,25 D980 8 ZN	MUTTER M8X 1,25 D980 8 ZN	TUERCA M8X 1,25 D980 8 ZN
39	F01020063R	VITE M8X1,25X35 U5737 8.8ZN	SCR. M8X1,25X35 U5737 8.8ZN	VIS M8X1,25X35 U5737 8.8ZN	SCHRAU. M8X1,25X35 U5737 8.8ZN	TORN. M8X1,25X35 U5737 8.8ZN
40	G16015981R	SCONTRO DI FISSAGGIO ZN	SECURING STOP TEETH	BUTEE DE FIXATION	FESTANSCHLAG	DIENTE DE PARADA DE FIJACI N
41	F01020125R	VITE M10X1,5X75 U5737 8.8ZN	SCR. M10X1,5X75 U5737 8.8ZN	VIS M10X1,5X75 U5737 8.8ZN	SCHRAU. M10X1,5X75 U5737 8.8ZN	TORN. M10X1,5X75 U5737 8.8ZN
42	F01220033R	DADO M10X1,5 D980 8ZN	NUT M10X1,5 D980 8ZN	ECROU M10X1,5 D980 8ZN	MUTTER M10X1,5 D980 8ZN	TUERCA M10X1,5 D980 8ZN
43	G16043760R	ASS.SUPP.INF.RASCHIATERRA DX	ASS.SUPP.LOWER R.SOILSCRAPER			
44	G16043740R	ASS.SUPP.INF.RASCHIATERRA SX	ASS.SUPP.LOWER L.SOILSCRAPER			
45	F01230022R	DADO M6X1 D982 8ZN	NUT M6X1 D982 8ZN	ECROU AUTO-FREIN.M6X1 D982 8ZN	SICHERUNGSMUT. M6X1 D982 8 ZN	TUERCA DE SEGU.M6X1 D982 8 ZN
46	G16043852R	LIMITATORE DI PROF.DX	RIGHT DEPTH CONTROLLER			
47	F01420037R	ROS.M6 6.4X 24X1,5 U6593 ZN	WASHER M6 6.4X24X1,5 U6593 ZN			
48	G18904240R	MOLLA L=17 D.FILO=1.3 SP.=7	SPRING L=17 D.1.3	RESSORT	FEDER	MUELLE
49	F01020042R	VITE M6X1X50 U5737 8.8ZN	SCR. M6X1X50 U5737 8.8ZN	VIS M6X1X50 U5737 8.8ZN	SCHRAU. M6X1X50 U5737 8.8ZN	TORN. M6X1X50 U5737 8.8ZN
50	G16043842R	LIMITATORE DI PROF.SX	LEFT DEPTH CONTROLLER			
51	G16045740R	PERNO D.10X32 ZN	GALVAN. PIN D.10X32		PIN D.10X32 ZN	
52	F02200342R	COPIGLIA R 2X 50 ZN	SPRING SPLIT PIN 2X50 GALV.	GOUPILLE R 2X50 ZN	SPLINT R 2X50 ZN	CHAVETA R 2X50 ZN
53	G16043462R	SUPPORTO RUOTINO	WHEEL SUPPORT			
54	F06120409R	RUOTA GOMMA 250X42L PLA.2CUS.	RUBBER WHEEL 250X42L PLA.2BEAR			
55	F04010131R	CUSC.D20 D42 B12 6004-2RSH EX	BEARING D20 D42 B12 6004-2RSH	ROULEMENT D20 B12	LAGER 6004	COJINETE 6004
56	G16043830R	BOCCOLA D10XD29-13 ZN	BUSHING D10XD29-13 ZN			
57	F01060091R	VITE M10X1,5X70 U5731 8.8ZN	SCREW M10X1,5X70 U5731 8.8 GAL			
58	G19004350R	MANICOTTO PIEGATO	BEND SLEEVE			
59	G16045500R	SUPPORTO RASCHIA RUOTINO250X42	SOIL SCRAPER SUPPORT			

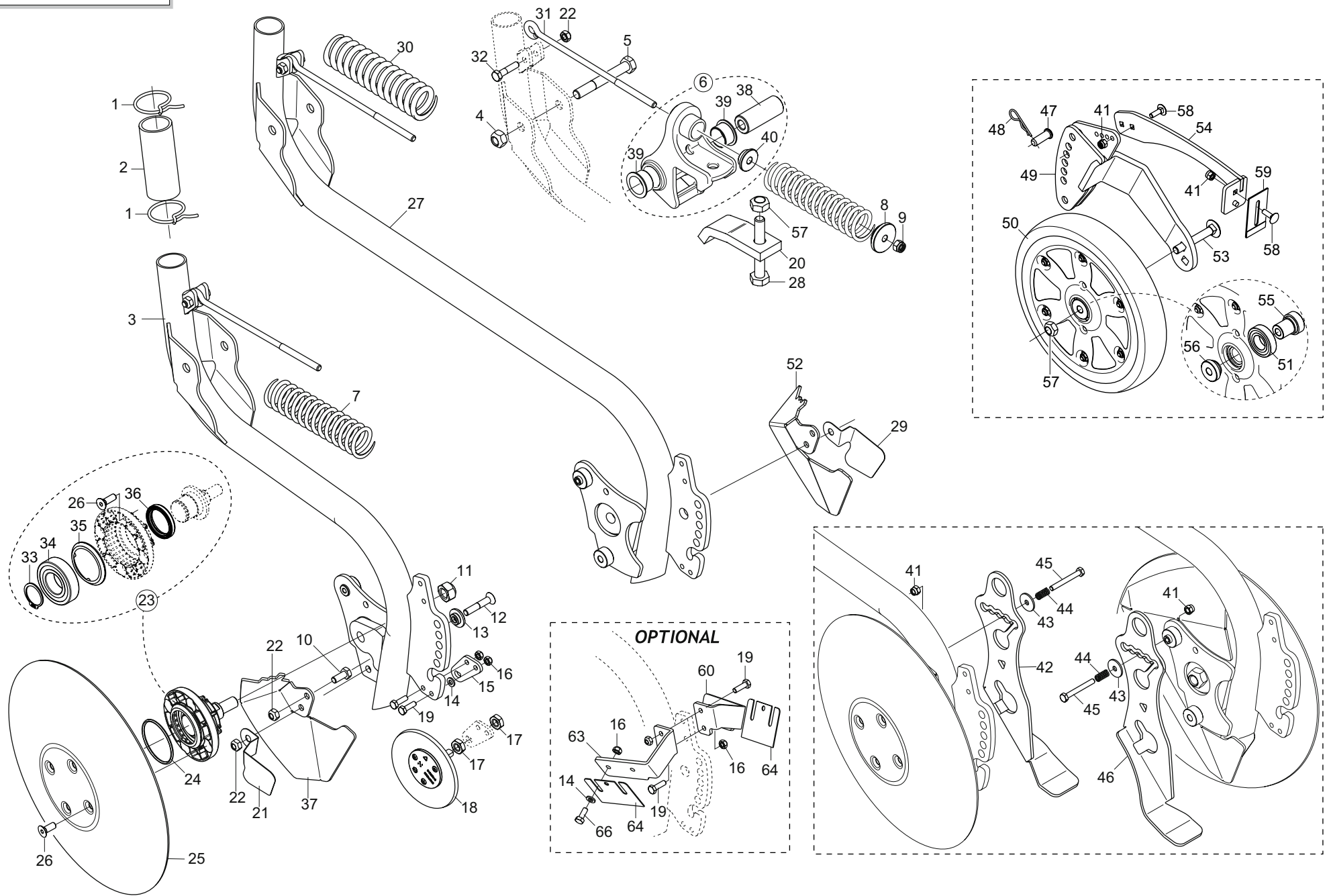

**ASSOLCATORI A DISCO SEMPLICE «DV»
SINGLE DISC COULTERS «DV»**

TAV. 220

Pos.	Cod.	Descrizione	Description	Description	Benennung	Descripcion
1	G65336001R	MOLLA SPEC.ZN STRING.CONC. SP	SPEC SPRING ZN MAN. PIPE CLAMP	RESSORT SPEC. ZN SERRE-TUBE LO	SPEZIALFEDER ZN DSNERSCHELLE.	MUELLE ESPEC. ZN APLASTA ABONO
2	G19005340R	MANICOTTO DI GIUNZIONE	JOINT SLEEVE	MANCHON DE RACCORD	VERBINDUNGSMUFFE	MANGUITO DE UNIN
3	G16043691R	TUBO CORTO E TIRANTE	SHORT TUBE & TIGHTENER			
4	F01220048R	DADO M12X1,75 D980 8ZN	NUT M12X1,75 D980 8ZN	ECROU M12X1,75 D980 8 ZN	SCHEIBE M12X1,75 D980 8 ZN	TUERCA M12X1,75 D980 8 ZN
5	F01020168R	VITE M12X1,75X90 U5737 8.8ZN	SCR. M12X1,75X90 U5737 8.8ZN	VIS M12X1,75X90 U5737 8.8 ZN	SCHRAB.M12X1,75X90 5737 8.8 ZN	TORNIL.M12X1,75X90 5737 8.8 ZN
6	G16043680R	SUPPORTO ASSOLCATORE COMPL.	FURROW SUPPORT COMPL.			
7	G18904420R	MOLLA TENS.ASSOLCAT.CORTO ZN	SPRING TENSION FURROW SHORT			
8	G16041260R	FONDELLO ZN	BOTTOM GALV.ED			
9	F01230034R	DADO M8X1,25 D982 8ZN	NUT M8X1,25 D982 8ZN	ECROU M8X 1,25 ZN	MUTTER M8X 1,25 D982 8 ZN	TUERCA M8X 1,25 D982 8 ZN
10	F01020436R	VITE M8X1,25X20 U5739 8.8ZN	SCR. M8X1,25X20 U5739 8.8ZN	VIS M8X1,25X 20 U5739 8.8 ZN	SCHRAUBE M8X1,25X20U5739 8.8ZN	TORN. M8X1,25X20 U5739 8.8 ZN
11	F01220255R	DADO M14X2 D980 8ZN	NUT M14X2 D980 8ZN	ECROU M14X2 D980 8 ZN	MUTTER M14X2 D980 8 ZN	TUERCA M14X2 D980 8 ZN
12	F01030061R	VITE M8X1,25X45 U5933 10.9ZD	SCR. M8X1,25X45 U5933 10.9ZD	VIS 8X45 5933 8.8 ZN	SCHRAUBE 8X45 5933 8.8 ZN	TORNILLO 8X45 5933 8.8 ZN
13	G15821110R	BOCCOLA SUPPORTO COPRISEME	SEED COVER SUPP. BUSHING	BOITE SUPPORT COUVRE-SEMENCE	BSCHE SAMENABDECKERHALTER.	CASQUILLO SOPORTE CUBRESEMILLA
14	F01410037R	ROS.M6 6.4X12,5X1,6 U6592 ZN	WASHER M6 6,4X12,5X1,6 U6592ZN	RONDEL.M6 6,4X12,5X1,6 U6592ZN	SCHEIB.M6 6,4X12,5X1,6 U6592ZN	ARAND.M6 6,4X12,5X1,6 U6592 ZN
15	G16044540R	SUPP.RASCHIETTO ROTATIVO ZN	SCRAPER SUPPORT			
16	F01220011R	DADO M6X1 D980 8ZN	NUT M6X1 D980 8ZN	ECROU M6X1 D980 8 ZN	MUTTER M6X1 D980 8 ZN	TUERCA M6X1 D980 8 ZN
17	F01200416R	DADO M10X1,5 U5589 CL8 ZN 6SZN	NUT M10X1,5 U5589 6SZN	ECROU 10 UNI 5589 6.8 ZN	MUTTER 10 UNI 5589 6.8 ZN	TUERCA 10 UNI 5589 6.8 ZN
18	G16044280R	RASCHIETTO ROTATIVO COMPL	SCRAPER			
19	F01020404R	VITE M6X1X20 U5739 8.8ZN	SCREW M6X1X20 U5739 8.8ZN	VIS M6X1X20 U5739 8.8ZN	SCHRAUBE M6X1X20 U5739 8.8ZN	TORNILLO M6X1X20 U5739 8.8ZN
20	G16015981R	SCONTRO DI FISSAGGIO ZN	SECURING STOP TEETH	BUTEE DE FIXATION	FESTANSCHLAG	DIENTE DE PARADA DE FIJACI N
21	G16249050R	SUPPORTO LAMELLA DS SX IX	BLADE SUPPORT DS SX IX			
22	F01220022R	DADO M8X1,25 D980 8ZN	NUT M8X1,25 D980 8ZN	ECROU M8X 1,25 D980 8 ZN	MUTTER M8X 1,25 D980 8 ZN	TUERCA M8X 1,25 D980 8 ZN
23	G16044571R	MOZZO DISCO COMPL	DISC HUB ASS.BLY			
24	F03011144R	GUARNIZIONE OR 3 X 56	O-RING GASKET 3 X 56			
25	G16044560R	DISCO ASSOLCAT.VX D.320	DISK OPENER VX D.320			
26	F01030054R	VITE M8X1,25X16 U5933 10.9 ZD	SCREW M8X1,25X16 U5933 10.9 GA	VIS M8X1,25X16 U5933 10.9 ZD	SCHRAU.M8X1,25X16 U5933 10.9ZD	TORNI.M8X1,25X16 U5933 10.9 ZD
27	G16043701R	TUBO LUNGO E TIRANTE	LONG TUBE & TIGHTENER			
28	F01020125R	VITE M10X1,5X75 U5737 8.8ZN	SCR. M10X1,5X75 U5737 8.8ZN	VIS M10X1,5X75 U5737 8.8ZN	SCHRAU. M10X1,5X78 U5737 8.8ZN	TORN. M10X1,5X75 U5737 8.8ZN
29	G16249040R	SUPPORTO LAMELLA DS DX IX	BLADE SUPPORT DS DX IX			
30	G18904631R	MOLLA TENS.ASSOLCAT.LUNGO ZN	SPRING TENSION FURROW LONG			
31	G16041251R	TIRANTE	TIE ROD			
32	F01020063R	VITE M8X1,25X35 U5737 8.8ZN	SCR. M8X1,25X35 U5737 8.8ZN	VIS M8X1,25X35 U5737 8.8ZN	SCHRAU. M8X1,25X35 U5737 8.8ZN	TORN. M8X1,25X35 U5737 8.8ZN
33	F02050112R	ANELLO E.DE 30X 1,5 U7435 ZN	SEEGER RING 30X 1,5 U7435 C70	SEEGER E. 30 X 1,5 U7435 C70	SEEGERING E. 30X 1,5 U7435 C70	ANILLO E. 30 X 1,5 U7435 C70
34	F04010174R	CUSCINETTO 6206 2RS	BEARING D30 D62 B16 6206 2RS	PALIER 6206 2RS	LAGER 6206 2RS	COJINETE 6206 2RS
35	G16244181R	ANELLO DI SOSTEGNO ZAMA	RING	BAGUE	RING	ANILLO
36	F03010074R	ANELLO T.A. 32X 47X 7 D3760NBR	RING T.A. 32X 47X 7 D3760NBR	BAGUE 32X 47X 7 D3760NBR	SCHUTZRING 32X 47X 7 D3760NBR	ANILLO T.A. 32X 47X 7 D3760NBR
37	G16045760R	GUSCIO DISCO VORTEX ELEM.CORTO	VORTEX DISC SHELL SHORT ELEM.			
38	G18802740R	BOCCOLA 25X12X63,5	BUSHING 25X12X63,5	BOITE 25X12X63,5	BUCHSE 25X12X63,5	CASQUILLO 25X12X63,5
39	F04150034R	CUSCINETTO FLANGIATO 25X28X16	BEARING FLANGED 25X28X16			
40	G19006510R	BOCCOLA GUIDA TIRANTE	BUSHING TIE-ROD GUIDE			
41	F01230022R	DADO M6X1 D982 8ZN	NUT M6X1 D982 8ZN	ECROU AUTO-FREIN.M6X1 D982 8ZN	SICHERUNGSMUT. M6X1 D982 8 ZN	TUERCA DE SEGU.M6X1 D982 8 ZN
42	G16043852R	LIMITATORE DI PROF.DX	RIGHT DEPTH CONTROLLER			
43	F01420037R	ROS.M6 6.4X 24X1,5 U6593 ZN	WASHER M6 6,4X24X1,5 U6593 ZN			
44	G18904240R	MOLLA L=17 D.FILO=1.3 SP.=7	SPRING L=17 D.1.3	RESSORT	FEDER	MUELLE
45	F01020042R	VITE M6X1X50 U5737 8.8ZN	SCR. M6X1X50 U5737 8.8ZN	VIS M6X1X50 U5737 8.8ZN	SCHRAU. M6X1X50 U5737 8.8ZN	TORNI. M6X1X50 U5737 8.8ZN
46	G16043842R	LIMITATORE DI PROF.SX	LEFT DEPTH CONTROLLER			
47	G16045740R	PERNO D.10X32 ZN	GALVAN. PIN D.10X32		PIN D.10X32 ZN	
48	F02200342R	COPIGLIA R 2X 50 ZN	SPRING SPLIT PIN 2X50 GALV.	GOUPILLE R 2X50 ZN	SPLINT R 2X50 ZN	CHAVETA R 2X50 ZN
49	G16043462R	SUPPORTO RUOTINO	WHEEL SUPPORT			
50	F06120409R	RUOTA GOMMA 250X42L PLA.2CUS.	RUBBER WHEEL 250X42L PLA.2BEAR			
51	F04010131R	CUSC.D20 D42 B12 6004-2RSH EX	BEARING D20 D42 B12 6004-2RSH	ROULEMENT D20 B12	LAGER 6004	COJINETE 6004
52	G16045750R	GUSCIO DISCO VORTEX ELEM.LUNGO	VORTEX DISC SHELL LONG ELEMENT			
53	F01060091R	VITE M10X1,5X70 U5731 8.8ZN	SCREW M10X1,5X70 U5731 8.8 GAL			
54	G16045500R	SUPPORTO RASCHIA RUOTINO250X42	SOIL SCRAPER SUPPORT			
55	G16043820R	BOCCOLA D10XD29-35 ZN	BUSHING D10XD29-35 ZN			
56	G16043830R	BOCCOLA D10XD29-13 ZN	BUSHING D10XD29-13 ZN			
57	F01220033R	DADO M10X1,5 D980 8ZN	NUT M10X1,5 D980 8ZN	ECROU M10X1,5 D980 8ZN	MUTTER M10X1,5 D980 8ZN	TUERCA M10X1,5 D980 8ZN
58	F01060013R	VITE M6X1X20 U5731 8.8ZN	SCR. M6X1X20 U5732 4.6ZN	VIS 6X20 5732 4.6 ZN	SCHRAUBE 6X20 5732 4.6 ZN	TORNILLO 6X20 5732 4.6 ZN
59	G16043880R	RASCHIATERRA DS CON RIPORTO ZN	SOILSCRAPER DS ZN	CROTTOIR DS AVEC REPORT		
60	G16045790R	SUPPORTO RASCHIATERRA DX	SUPPORT SOIL SCRAPER RIGHT			
63	G16045780R	SUPPORTO RASCHIATERRA SX	SUPPORT SOIL SCRAPER LEFT			
64	G17940750R	RASCHIATERRA DISCO	SOIL SCRAPER DISC			RASCADOR DISCO
66	F01020403R	VITE M6X1X16 U5739 8.8ZN	SCR. M6X1X16 U5739 8.8ZN	VIS M6X1X16 U5739 8.8 ZN	SCHRAUBE M6X1X16 U5739 8.8 ZN	TORNILLO M6X1X16 U5739 8.8 ZN

TAV. 230

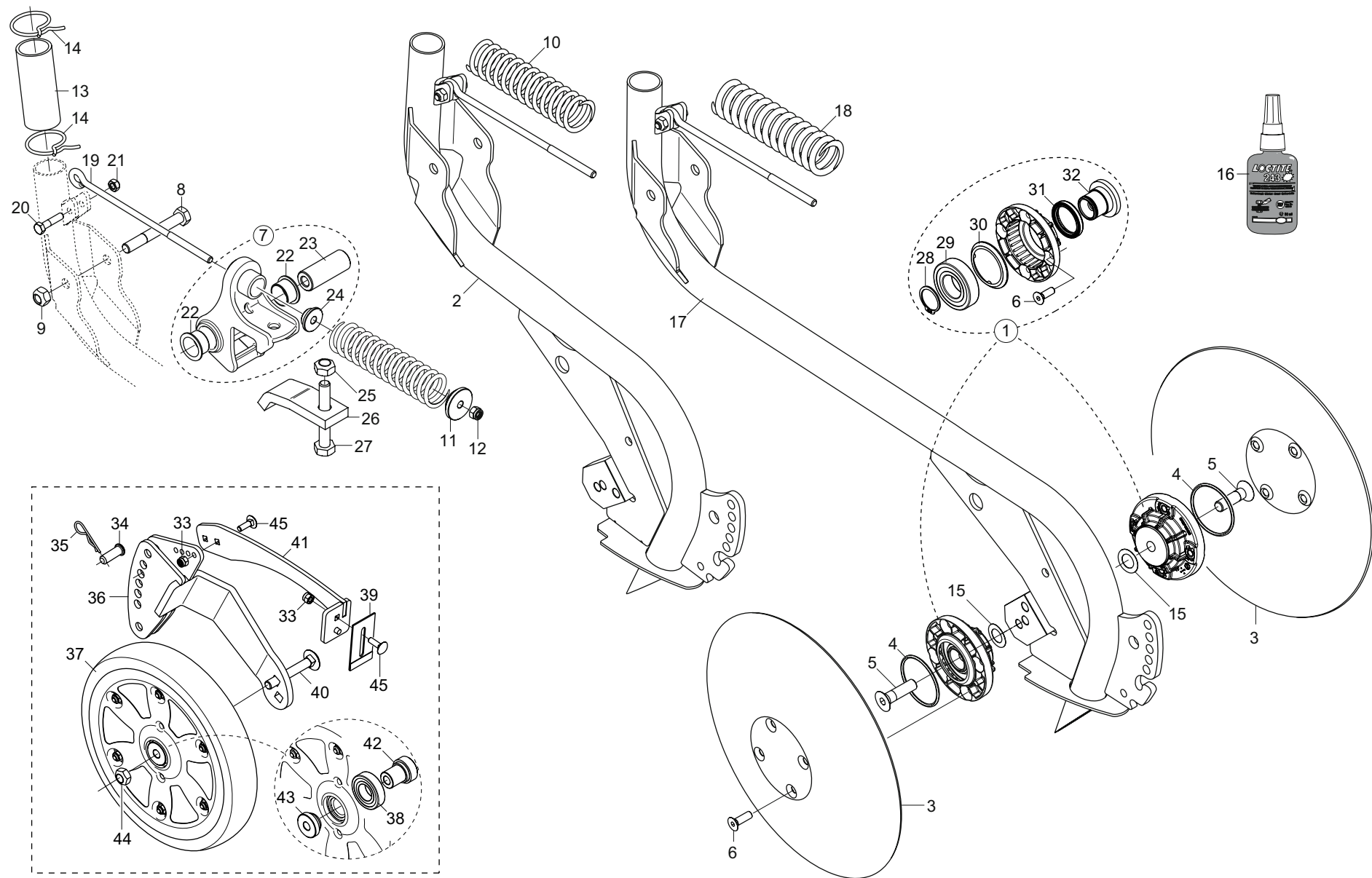

**ASSOLCATORI A DISCO «COREX»
«COREX» DISC COULTERS**

TAV. 230

Pos.	Cod.	Descrizione	Description	Description	Benennung	Description
1	G16248851R	KIT MOZZO COREX	KIT COREX HUB			
2	G16045411R	TUBO CORTO COREX E TIRANTE	SHORT COREX TUBE			
3	G16043090R	DISCO COREX FE-B SP.2,5	DISC COREX FE-B SP.2,5	DISC COREX GALVANISE SP2,5		DISCO COREX FE-B SP.2,5
4	F03011144R	GUARNIZIONE OR 3 X 56	O-RING GASKET 3 X 56			
5	F01030112R	VITE M12X1,75X45 U5933 10.9ZD	SCREW M12X1,75X45 U5933 10.9GA	VIS M12X1,75X45 U5933 10.9 ZD	SCHRAUBE M12X1,75X45 U5933 10.	TORNIL. M12X1,75X45 U5933 10.9
6	F01030055R	VITE M8X1,25X20 U5933 10.9ZD	SCR. M8X1,25X20 U5933 10.9ZD	VIS M 8X20	SCHRAUBE M 8X20	TORNILLO M 8X20
7	G16043680R	SUPPORTO ASSOLCATORE COMPL.	FURROW SUPPORT COMPL.			
8	F01020168R	VITE M12X1,75X90 U5737 8.8ZN	SCR. M12X1,75X90 U5737 8.8ZN	VIS M12X1,75X90 U5737 8.8 ZN	SCHHRAB.M12X1,75X90 5737 8.8 ZN	TORNIL.M12X1,75X90 5737 8.8 ZN
9	F01220048R	DADO M12X1,75 D980 8ZN	NUT M12X1,75 D980 8ZN	ECROU M12X1,75 D980 8 ZN	SCHEIBE M12X1,75 D980 8 ZN	TUERCA M12X1,75 D980 8 ZN
10	G18904420R	MOLLA TENS.ASSOLCAT.CORTO ZN	SPRING TENSION FURROW SHORT			
11	G16041260R	FONDELLO ZN	BOTTOM GALV.ED			
12	F01230034R	DADO M8X1,25 D982 8ZN	NUT M8X1,25 D982 8ZN	ECROU M8X 1,25 ZN	MUTTER M8X 1,25 D982 8 ZN	TUERCA M8X 1,25 D982 8 ZN
13	G19005340R	MANICOTTO DI GIUNZIONE	JOINT SLEEVE	MANCHON DE RACCORD	VERBINDUNGSMUFFE	MANGUITO DE UNIN
14	G65336001R	MOLLA SPEC.ZN STRING.CONC. SP	SPEC SPRING ZN MAN. PIPE CLAMP	RESSORT SPEC. ZN SERRE-TUBE LO	SPEZIALFEDER ZN DSNNGERSHELLE.	MUELLE ESPEC. ZN APLASTAABONO
15	G22220073R	RONDELLA 28X0,3X16,5	WASHER 28X0-3X16-5	RONDELLE 28X0-3X16-5	UNTERLEGSCHIEBE 28X0-3X16-5	ARANDELA 28X0-3X16-5
16	F03240018R	LOCTITE 243 1X250 ML.	LOCTITE*243 1X250 ML..	LOCTITE*243 1X250 ML.	LOCTITE*243 1X250 ML.	LOCTITE*243 1X250 ML.
17	G16045371R	TUBO LUNGO COREX E TIRANTE	LONG COREX TUBE			
18	G18904631R	MOLLA TENS.ASSOLCAT.LUNGO ZN	SPRING TENSION FURROW LONG			
19	G16041251R	TIRANTE	TIE ROD			
20	F01020063R	VITE M8X1,25X35 U5737 8.8ZN	SCR. M8X1,25X35 U5737 8.8ZN	VIS M8X1,25X35 U5737 8.8ZN	SCHRAU. M8X1,25X35 U5737 8.8ZN	TORN. M8X1,25X35 U5737 8.8ZN
21	F01220022R	DADO M8X1,25 D980 8ZN	NUT M8X1,25 D980 8ZN	ECROU M8X 1,25 D980 8 ZN	MUTTER M8X 1,25 D980 8 ZN	TUERCA M8X 1,25 D980 8 ZN
22	F04150034R	CUSCINETTO FLANGIATO 25X28X16	BEARING FLANGED 25X28X16			
23	G18802740R	BOCCOLA 25X12X63,5	BUSHING 25X12X63,5	BOITE 25X12X63,5	BUCHSE 25X12X63,5	CASQUILLO 25X12X63,5
24	G19006510R	BOCCOLA GUIDA TIRANTE	BUSHING TIE-ROD GUIDE			
25	F01220033R	DADO M10X1,5 D980 8ZN	NUT M10X1,5 D980 8ZN	ECROU M10X1,5 D980 8ZN	MUTTER M10X1,5 D980 8ZN	TUERCA M10X1,5 D980 8ZN
26	G16015981R	SCONTRO DI FISSAGGIO ZN	SECURING STOP TEETH	BUTEE DE FIXATION	FESTANSCHLAG	DIENTE DE PARADA DE FIJACI N
27	F01020125R	VITE M10X1,5X75 U5737 8.8ZN	SCR. M10X1,5X75 U5737 8.8ZN	VIS M10X1,5X75 U5737 8.8ZN	SCHRAU. M10X1,5X78 U5737 8.8ZN	TORN. M10X1,5X75 U5737 8.8ZN
28	F02050112R	ANELLO E.DE 30X 1,5 U7435 ZN	SEEGER RING 30X 1,5 U7435 C70	SEEGER E. 30 X 1,5 U7435 C70	SEEGERING E. 30X 1,5 U7435 C70	ANILLO E. 30 X 1,5 U7435 C70
29	F04010174R	CUSCINETTO 6206 2RS	BEARING D30 D62 B16 6206 2RS	PALIER 6206 2RS	LAGER 6206 2RS	COJINETE 6206 2RS
30	G16244181R	ANELLO DI SOSTEGNO ZAMA	RING	BAGUE	RING	ANILLO
31	F03010074R	ANELLO T.A. 32X 47X 7 D3760NBR	RING T.A. 32X 47X 7 D3760NBR	BAGUE 32X 47X 7 D3760NBR	SCHUTZRING 32X 47X 7 D3760NBR	ANILLO T.A. 32X 47X 7 D3760NBR
32	G16244050R	ASSE COREX ZN	AXLE COREX ZN		ACHSE COREX ZN	EJE COREX ZN
33	F01230022R	DADO M6X1 D982 8ZN	NUT M6X1 D982 8ZN	ECROU AUTO-FREIN.M6X1 D982 8ZN	SICHERUNGSMUT. M6X1 D982 8 ZN	TUERCA DE SEGU.M6X1 D982 8 ZN
34	G16045740R	PERNO D.10X32 ZN	GALVAN. PIN D.10X32		PIN D.10X32 ZN	
35	F02200342R	COPIGLIA R 2X 50 ZN	SPRING SPLIT PIN 2X50 GALV.	GOUPILLE R 2X50 ZN	SPLINT R 2X50 ZN	CHAVETA R 2X50 ZN
36	G16043462R	SUPPORTO RUOTINO	WHEEL SUPPORT			
37	F06120409R	RUOTA GOMMA 250X42L PLA.2CUS.	RUBBER WHEEL 250X42L PLA.2BEAR			
38	F04010131R	CUSC.D20 D42 B12 6004-2RSH EX	BEARING D20 D42 B12 6004-2RSH	ROULEMENT D20 B12	LAGER 6004	COJINETE 6004
39	G16043880R	RASCHIATERRA DS CON RIPORTO ZN	SOILSCRAPER DS ZN	CROTTOIR DS AVEC REPORT		
40	F01060091R	VITE M10X1,5X70 U5731 8.8ZN	SCREW M10X1,5X70 U5731 8.8 GAL			
41	G16045500R	SUPPORTO RASCHIA RUOTINO250X42	SOIL SCRAPER SUPPORT			
42	G16043820R	BOCCOLA D10XD29-35 ZN	BUSHING D10XD29-35 ZN			
43	G16043830R	BOCCOLA D10XD29-13 ZN	BUSHING D10XD29-13 ZN			
44	F01220033R	DADO M10X1,5 D980 8ZN	NUT M10X1,5 D980 8ZN	ECROU M10X1,5 D980 8ZN	MUTTER M10X1,5 D980 8ZN	TUERCA M10X1,5 D980 8ZN
45	F01060013R	VITE M6X1X20 U5731 8.8ZN	SCR. M6X1X20 U5732 4.6ZN	VIS 6X20 5732 4.6 ZN	SCHRAUBE 6X20 5732 4.6 ZN	TORNILLO 6X20 5732 4.6 ZN

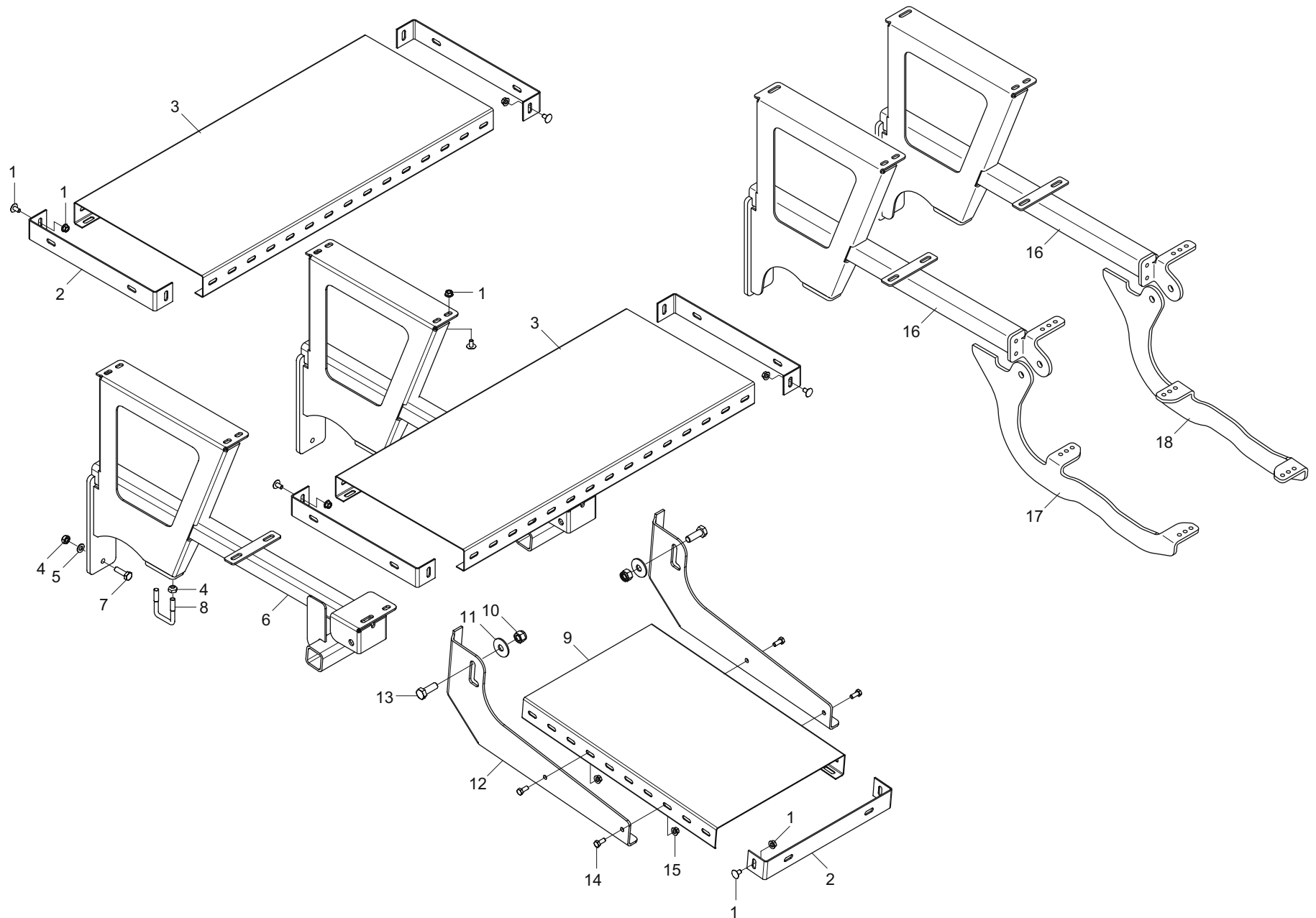

**PEDANA DI ISPEZIONE E SCALETTA
INSPECTION FOOTBOARD WITH LADDER**

TAV. 240

Pos.	Cod.	Descrizione	Description	Description	Benennung	Descripcion
1	F01030495R	VITE TTCN 90 M8X16 ZN	TTCN 90 BOLT M8X16 GALVANIZED	VIS TTCN 90 M8X16 ZN	SCHRAUBE TTCN 90 M8X16 ZN	TORNILLO TTCN 90 M8X16 ZN
2	G16310681R	TERMINALE PEDANA 400 ZN	GALVANIZED PLATFORM END			
3	G16016320R	PEDANA 400X900X58 ZN	PLATFORM 400X900X58 ZN			
4	F01220033R	DADO M10X1,5 D980 8ZN	NUT M10X1,5 D980 8ZN	ECROU M10X1,5 D980 8ZN	MUTTER M10X1,5 D980 8ZN	TUERCA M10X1,5 D980 8ZN
5	F01410064R	ROS.M10 10,5X 20X 2 U6592 ZN	WASHER M10 10,5X20X2 U6592 ZN	RONDEL. M10 10,5X20X2 U6592 ZN	SCHEIBE M10 10,5X20X2 U6592 ZN	ARANDEL.M10 10,5X20X2 U6592 ZN
6	G16075310R	SUPPORTO PEDANA	PLATFORM SUPPORT			
7	F01020479R	VITE M10X1,5X35 U5739 8.8ZN	SCR. M10X1,5X35 U5739 8.8ZN	VIS M10X1,5X35 U5739 8.8 ZN	SCHR. M10X1,5X35 U5739 8.8 ZN	TORN. M10X1,5X35 U5739 8.8 ZN
8	F20110705R	CAV.Q.B=40 M=10X1,5 L=62	U BOLT Q,B=40 M=10X1,5 L=62	CAVALIER ZN	BSGELBOLZEN ZN	PERNO EN U ZN
9	G17917220R	PEDANA 400 X 600 X 58 SP2 ZN	BOARD 400 X 600 X 58 SP2 ZN			
10	F01230073R	DADO M14X2 D982 8ZN	SELF LOCK NUT M14X2 D982 8ZN	ECROU AUTOBL.M14X2 ZN	SELBSTSP.MUTT. M14X2 D982 8ZN	TUERCA AUTOBL. M14X2 D982 8ZN
11	F01420084R	ROS.M14 14,5X 36X 3 U6593 ZN	GALVANIZED WASHER 14 X36 X3	RONDELLE 14 X36 X3 ZN	UNTERLEGSCHIEBE 14 X36 X3 ZN	ARANDELA 14 X36 X3 ZN
12	G16314480R	SUPPORTO PEDANA	BOARD SUPPORT			
13	F01020544R	VITE M14X2X40 U5739 8.8ZN	SCR. M14X2X40 U5739 8.8ZN	VIS M14X2X40 U5739 8.8ZN	SCHR.M14X2X40 U5739 8.8ZN	TOR.M14X2X40 U5739 8.8ZN
14	F01020436R	VITE M8X1,25X20 U5739 8.8ZN	SCR. M8X1,25X20 U5739 8.8ZN	VIS M8X1,25X 20 U5739 8.8 ZN	SCHRAUBE M8X1,25X20U5739 8.8ZN	TORN. M8X1,25X20 U5739 8.8 ZN
15	F01260043R	DADO M8 D6923 8.8ZN	NUT M8 D6923 8.8ZN	ECROU BRIDE .M8 DIN 6923 8.8 Z	GEFLANSCHTE MUTTER M8 DIN6923	TUERCA BRIDA M8 DIN 6923 8.8 Z
16	G16075311R	SUPPORTO PEDANA	PLATFORM SUPPORT			
17	G16076100R	SUPPORTO SX SCALINO	LEFT STEP SUPPORT			
18	G16076110R	SUPPORTO DX SCALINO	RIGHT STEP SUPPORT			

TAV. 250

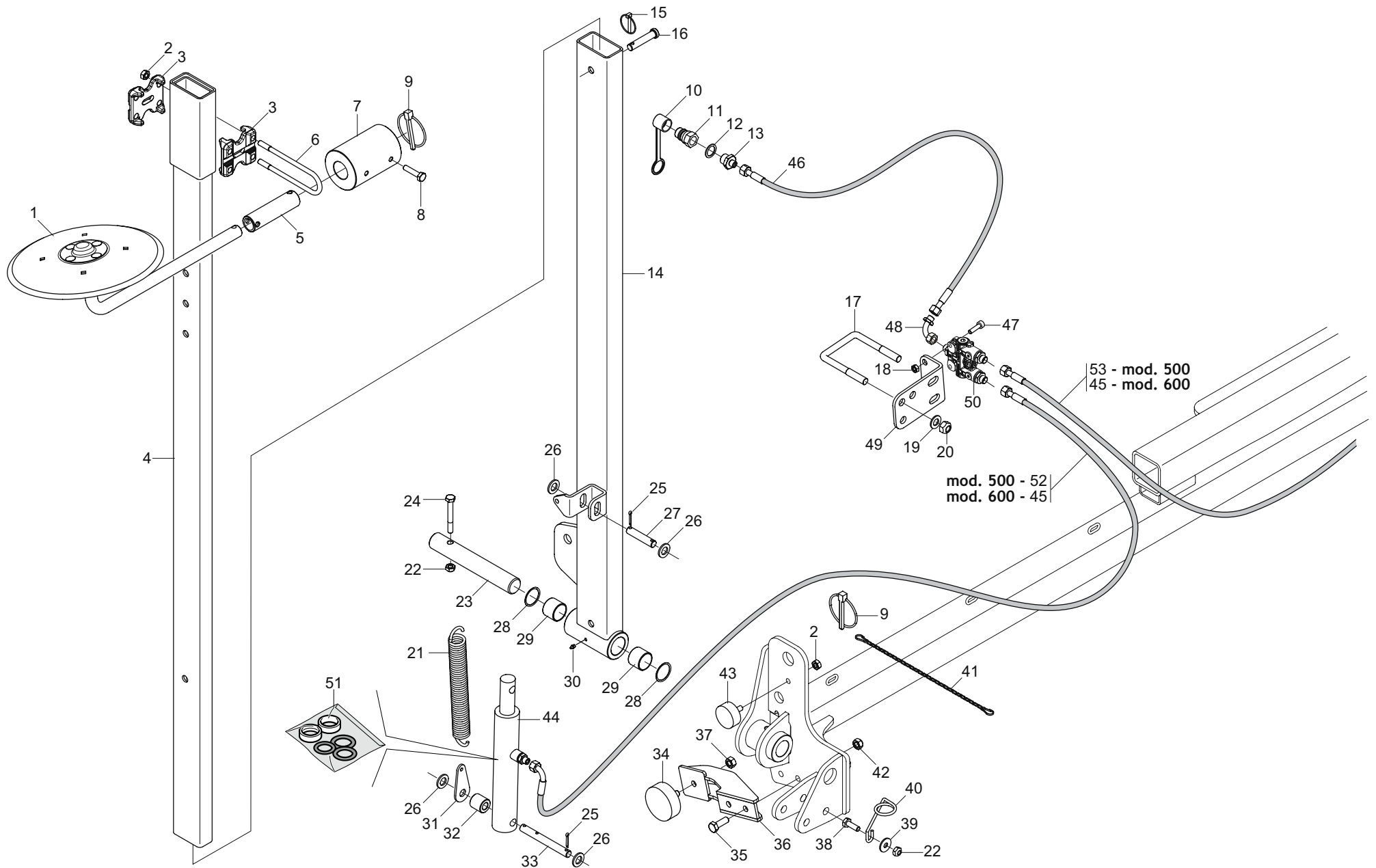

SEGNAFILE ROW MARKER

TAV. 250

Pos.	Cod.	Descrizione	Description	Description	Benennung	Descripcion
1	G17111481R	DISCO D.320 COMPL.MAGICA	DISK D.320 COMPLETE MAGICA			
2	F01200270R	DADO M10X1,5 U5588 CL8 ZN	NUT M10X1,5 U5588 6.8ZN	ECROU M10X 1,5 U5588 6.8 ZN	MUTTER M10X 1,5 U5588 6.8 ZN	TUERCA M10X 1,5 U5588 6.8 ZN
3	G19204230R	SUPPORTO MANICOTTO TQ.50	SLEEVE SUPPORT TQ.50			
4	G16075410R	BRACCIO TELESC.SEGNAFILE	TELESCOPIC ROWMARKER ARM			
5	G17111290R	MANICOTTO DISCO	DISC SLEEVE U BOLT	MANCHON DISQUE	SCHEIBENMUFFE	MANGUITO DISCO
6	F20110865R	CAV.T.M10X 1,5X 30 46X168,5ZN	U BOLT T.M10X1,5X30 46X L168,5	ETRIER EN U M10 ZN	U-BOLZEN M10 ZN	PERNO EN U M10 ZN
7	G16012950R	ZAVORRA	BALLAST	LEST	BALLAST	CONTRAPESO
8	F01020484R	VITE M10X1,5X45 U5739 8.8ZN	SCREW M10X1,5X45 U5739 8.8 GAL	VIS 10X45 5739 8.8 G ZN	SCHRAUBE 10X45 5739 8.8 G ZN	TORNILLO 10X45 5739 8.8 G ZN
9	F02200507R	SPINA A SCATTO D 9 B 83	SNAP PIN D9 B 83 ZN	FICHE A DETENTE D9 B 83 ZN	EINRASTSTIFT D9 B 83 ZN	CLAVIJA DE MUELLE D9 B 83 ZN
10	F05150325R	CAPPUC.F X INN.M RAP.1 2 ROSS	COVER CONNECT F 1 2 RED	COUVERCLE CONNEXION F 1 2 ROSE	DECKEL W 1 2 SCHNELLKUPP. ROT	PAC PROTECCION F 1 2 ROJO
11	F03150935R	INNESTO RAP.MASCH.1 2 A VALV.	QUICK CONNECT MALE CONE 1 2	CONNEXION RAPIDE MALE CONE 1 2	SCHNELLKUPP.GEWINDE KONISC 1 2	ACOPLAMIEN.RAP.MACHO CONO 1 2
12	F03151237R	ROS. 21 X27X1,5 RAME -1 2	COPPER WASHER 21X27X1,5 1 2	RONDELLE CUIVRE 21X27X1,5 1 2	SCHEIBE KUPFER 21X27X1,5 1 2	ARANDELA COBRE 21X27X1,5 1 2
13	F03150211R	NIPPLO MM CIL-CIL 1 2-1 4 ZN	NIPLE MM CIL-CIL 1 4-1 2 ZN	NIPLE MM 1 4-1 2 ZN	NIPLE GG 1 4-1 2 ZN	NIPLE MM 1 4-1 2 ZN
14	G16074860R	BRACCIO SEGNAFILE	ROWMARKER ARM			
15	F02200463R	SPINA SCATTO D5 B 81 ZN	SNAP PIN D5 B 81 ZN	FICHE A DETENTE D5 B 81 ZN	EINRASTSTIFT D5 B 81 ZN	CLAVIJA DE MUELLE D5 B 81 ZN
16	G07002569R	PERNO 14 X68 ZN	PIN	PIVOT	ZAPFEN	PERNO
17	F20110770R	CAV.Q.B=80 M=14X2 L=119	U BOLT Q.B=80 M=14X2 L=119	BRIDE U M14X2X50 96X119 ZN	ANSCHLANG U M14X2X50 96X119 ZN	EL.DE EMPALME M14X2X50 96X119
18	F01200244R	DADO M8X1,25 U5588 CL8 ZN	NUT M8X1,25 U5588 6.8ZN	ECROU M8 X1,25 U5588 6.8 ZN	MUTTER M8 X1,25 U5588 6.8 ZN	TUERCA M8 X1,25 U5588 6.8 ZN
19	F01410088R	ROS.M14 15X 28X2,5 U6592 ZN	WAS.M14 15X 28X2,5 U6592 ZB	RON.M14 15X 28X2,5 U6592 ZB	SCH.M14 15X 28X2,5 U6592 ZB	ARA.M14 15X 28X2,5 U6592 ZB
20	F01220255R	DADO M14X2 D980 8ZN	NUT M14X2 D980 8ZN	ECROU M14X2 D980 8 ZN	MUTTER M14X2 D980 8 ZN	TUERCA M14X2 D980 8 ZN
21	G65337004R	MOLLA TRAZ.SOLLEV. FU	TRACTION SPRING LIFT. FU	RESSORT TRACT. LEVAGE FU	ZUGFEDER HEBUNG FU	MUELLE TRAC. LEVDEL. FU
22	F01220033R	DADO M10X1,5 D980 8ZN	NUT M10X1,5 D980 8ZN	ECROU M10X1,5 D980 8ZN	MUTTER M10X1,5 D980 8ZN	TUERCA M10X1,5 D980 8ZN
23	G16011590R	PERNO SEGNAFILE ZN	BOLT ROW MAKER ZN			
24	F01020128R	VITE M10X1,5X80 U5737 8.8ZN	SCR. M10X1,5X80 U5737 8.8ZN	VIS M10X1,5X80 U5737 8.8 ZN	SCHRAU. M10X1,5X80 U5737 8.8ZN	TORNIL.M10X1,5X80 U5737 8.8 ZN
25	F02200194R	COPIGLIA 4X 25 U1336 ZN	SPLIT PIN 4 X25 1336 GALVAN.	GOUPILLE 4 X25 1336 ZN	SPLINT 4 X25 1336 ZN	PASADOR 4 X25 1336 ZN
26	F01410100R	ROS.M16 17X 30X 3 U6592 ZN	WASHER M16 17X30X3 U6592 ZN	RONDELLE M16 17X30X3 ZN	SCHRAUBE M16 17X 30X3 U6592 ZN	ARANDELA M16 17X30X 3 U6592 ZN
27	G15413010R	SPINA 15X62 ZN	PIN 15X62 ZN	GOUPILLE 15X62 ZN	BOLZENSTIFT 15X62 ZN	PASADOR 15X62 ZN
28	G18701800R	RONDELLA 35,5 X42 X0,5	WASHER 35,5 X42 X0,5	RONDELLE 35,5 X42 X0,5	UNTERLEGSCHHEIBE 35,5 X42 X0,5	ARANDELA 35,5 X42 X0,5
29	F04150053R	BOCCOLA GSM-3539-30	BUSHING GSM-3539-30			
30	F01100011R	ING.M 6X1 7663-A 9SMNPB28 ZN	GREASE NIPPLE M6X1 7663-A ZN	GRAISS. A BILLE M6X1 7663A ZN	SCHMIERBUECHE M6X1 7663-A ZN	ENGRAS. DE ESFE. M6X1 7663-AZN
31	G16012810R	ATTACCO MOLLA INFERIORE	LOWER SPRING COUPLING	FIXATION RESSORT INF.	UNTERER KUPPLUNG FEDER	CONEXI N MUELLE INFERIOR
32	G18802250R	BOCCOLA 15,25X30X30 ZN	BUSHING 15,25 X 30 X30 ZN	BOITE 15,25X30 X30 ZN	B CHSE 15,25X30 X30 ZN	CASQUILLO 15,25X30 X30 ZN
33	G15413020R	SPINA 15X120 ZN	GALVANIZED PIN 15X120	GOUPILLE 15X120 ZN	STIFT 15X120 ZN	CLAVIJA 15X120 ZN
34	F05150459R	PARACOLPI CIL. 75X25 SH71	CYLINDER GUARD 75X25 M12 SH71	TAMPON CIL. 75X25 M12	PUFFER CIL. 75X25 M12	PARACHOQ. CIL. 75X25 M12
35	F01020512R	VITE M12X1,75X35 U5739 8.8ZN	SCR. M12X1,75X35 U5739 8.8ZN	VIS M12X1,75X35 5739 8.8 ZN	SCHR. M12X1,75X35 5739 8.8 ZN	TORN. M12X1,75X35 5739 8.8 ZN
36	G16075810R	SUPPORTO APPOGGIO SEGNAFILE	ROWMARKER SUPPORT REST			
37	F01200293R	DADO M12X1,75 U5588 CL8 ZN	NUT M12X1,75 U5588 6S ZN	ECROU M12X1,75 U5588 6S ZN	MUTTER M12X1,75 U5588 6S ZN	TUERCA M12X1,75 U5588 6S ZN
38	F01020476R	VITE M10X1,5X30 U5739 8.8ZN	SCR. M10X1,5X30 U5739 8.8ZN	VIS M10X1,5X30 U5739 8.8 ZN	SCHRAUBE M10X1,5X30U5739 8.8ZN	TORNIL.M10X1,5X30 U5739 8.8 ZN
39	F01420060R	ROS.M10 10,5X 30X2,5 U6593 ZG	GALV.WASHER 10,5X30X2,5 U6593	RONDELLE 10,5X30	SCHEIBE 10,5X30	ARANDELA 10,5X30
40	G65336078R	MOLLA SPEC.ZN GUID.MICRO SV	SPEC.SPRING ZN MICRO GUIDE SV	RESSORT SPEC. ZN GUIDE MICRO S	SPEZIALFEDER ZN FSHR.MIKRO SV	MUELLE ESPEC. ZN GU A MICRO SV
41	G13812311R	CATENELLA CON MOSCHETTONE	CHAIN WITH SPRING CATCH	CHAINETTE AVEC MOUSQUETON	KETTE MIT KARABINERHAKEN	CADENA CON GANCHO
42	F01220048R	DADO M12X1,75 D980 8ZN	NUT M12X1,75 D980 8ZN	ECROU M12X1,75 D980 8 ZN	SCHEIBE M12X1,75 D980 8 ZN	TUERCA M12X1,75 D980 8 ZN
43	F05150460R	PARACOLPI CIL.D50X21 M10X26,5	RUBBER BUFFER- CYLINDR.D50X21	PARE-CHOCYS CYL. D50X21	PUFFER ZYL.50X21	PARAGOLPES CIL.D50X21
44	G15413110R	CILINDRO SEGNAFILE SP COMPL.	ROW MARKER CYLINDER SP	CYLINDRE TRACEUR SP	SYLINDER REIHENANREISSER SP	CILINDRO MARCADOR DE FILAS
45	G15413080R	TUBO 1 4 C-F L.4650	TUBE 1 4 C-F L.4650	TUBE 1 4 C-F L.4650	ROHR 1 4 C-F L.4650	TUBO 1 4 C-F L.4650
46	G22505140R	TUBO 1 4R2 C-F 1 4 L.2350 LM	TUBE 1 4R1 C-F 1 4 L.2350 LM	TUBE 1 4R2 C-F 1 4 L.2350 LM	ROHR 1 4R2 C-F 1 4 L.2350 LM	TUBO 1 4R2 C-F 1 4 L.2350 LM
47	F01040501R	VITE M8X1,25X25 D7984 8.8ZN	SCREW M8X1,25X25 D7984 8.8ZN	VIS M8X1,25X25 D7984 8.8ZN	SCHRAU. M8X1,25X25 D7984 8.8ZN	TORN. M8X1,25X25 D7984 8.8ZN
48	F03150859R	CURVA 90 F.GIREV.1 4 - M.1 4	ELBOW 90 F.SLEWING 1 4 -M.1 4	COUDE 90 F.TOURN.1 4 - M.1 4	KNIESTSCK 90 F.DREHB.1 4 - M.	CURVA 90 F.GIRAT.1 4 - M.1 4
49	G15412351R	SUPPORTO VALVOLA	VALVE SUPPORT			
50	G16611051R	MONT.VALVOLA SEGNAFILE BP	ROWMARKER VALVE ASSY.			
51	F03100191R	KIT GUARNIZ.CILINDRO 15413110	CYLINDER SEAL KIT 15413110	KIT GARNIT. CYLINDRE 15413110	KIT ZYLINDERDICHTUNG 15413110	KIT JUNTA CILINDRO 15413110
52	G15210561R	TUBO 1 4R2 CF1 4- F1 4 3500	PIPE 1 4R2 CF1 4- F1 4 3500	TUBE 1 4R2 CF1 4- F1 4 3500	ROHR 1 4R2 CF1 4- F1 4 3500	TUBO 1 4R2 CF1 4- F1 4 3500
53	G16012650R	TUBO R2 1 4 C-F L.4000	PIPE 1 4 R2 C-F 1 4 L.4000	TUBE 1 4 R2 C-F 1 4 L. 4000	ROHR 1 4 R2 C-F 1 4 L.4000	TUBO 1 4 R2 C-F 1 4 L.4000

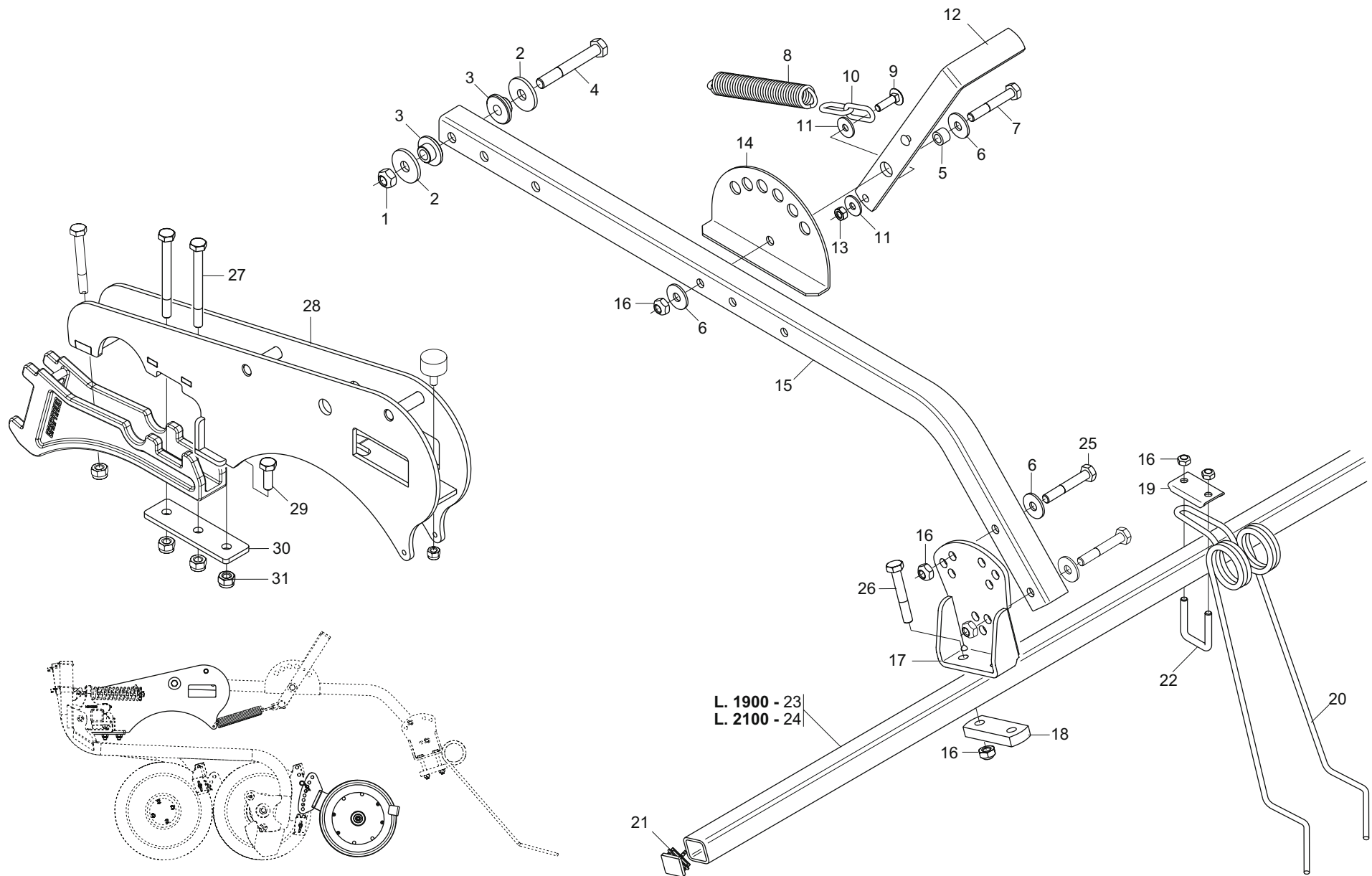

**ERPICE COPRISEME
SEED COVERING HARROW**

TAV. 260

Pos.	Cod.	Descrizione	Description	Description	Benennung	Descripcion
1	F01220048R	DADO M12X1,75 D980 8ZN	NUT M12X1,75 D980 8ZN	ECROU M12X1,75 D980 8 ZN	SCHEIBE M12X1,75 D980 8 ZN	TUERCA M12X1,75 D980 8 ZN
2	G20970085R	RONDELLA 40X4X13	WASHER 40X4X13	RONDELLE 40X4X13	UNTERLEGSCHEIBE 40X4X13	ARANDELA 40X4X13
3	G15421232R	BOCCOLA SINT.12,25X20 L.13 PAR	BUSHING SINT.12,25X20 L.13 PAR	BOITE BRAS PARALLELE SP.8	BSCHSE ARM PARALLEL SP.8	CASQUILLO BRAZO PARALELO SP.8
4	F01020168R	VITE M12X1,75X90 U5737 8.8ZN	SCR. M12X1,75X90 U5737 8.8ZN	VIS M12X1,75X90 U5737 8.8 ZN	SCHRAB.M12X1,75X90 5737 8.8 ZN	TORNIL.M12X1,75X90 5737 8.8 ZN
5	G18801610R	BOCCOLA 10,25X16 X11 ZN	BUSHING 10.25 X 16 X 11- GALVA	BOITE 10-25X16 X11 ZN	BSCHSE 10-25X16 X11 ZN	CASQUILLO 10-25X16 X11 ZN
6	F01420060R	ROS.M10 10,5X 30X2,5 U6593 ZG	GALV.WASHER 10,5X30X2,5 U6593	RONDELLE 10,5X30	SCHEIBE 10,5X30	ARANDELA 10,5X30
7	F01020120R	VITE M10X1,5X65 U5737 8.8ZN	SCR. M10X1,5X65 U5737 8.8ZN	VIS M10X1,5X65 U5737 8.8 ZN	SCHRA. M10X1,5X65 U5737 8.8 ZN	TORN. M10X1,5X65 U5737 8.8 ZN
8	G18903540R	MOLLA TRAZIONE SCARPETTE	PLANTER SHOE TRACTION SPRING	RESSORT TRACTION SABOTS	ZUGFEDER SZSCHAREN	MUELLE TRACCI N GU A APOYO
9	F01060042R	VITE M8X1,25X30 U5731 8.8ZN	SCR. M8X1,25X30 U5732 4.6ZN	VIS 8 X30 5732 4.6 ZN	SCHRAUBE 8 X30 5732 4.6 ZN	TORNILLO 8 X30 5732 4.6 ZN
10	G16015370R	CATENA GENOVESE D.5 ZN	CHAIN D.5 ZN	CHA NE D.5 ZN	KETTE D.5 ZN	CADENA 5 ZN
11	F01420048R	ROS.M8 8,4X 24X 2 U6593 ZN	WASHER M8 8,4X 24X2 U6593 ZN	RONDELLE M8 8,4X24X 2 U6593 ZN	SCHEIBEN M8 8,4X24X 2 U6593 ZN	ARANDELA M8 8,4X 24X2 U6593 ZN
12	G16013970R	LEVA TENDIMOLLA	SPRING EXTENDER LEVER	LEVIER TENDEUR RESSORT	HEBEL FEDERSpanNER	PALANCA TIRA MUELLE
13	F01200244R	DADO M8X1,25 U5588 CL8 ZN	NUT M8X1,25 U5588 6.8ZN	ECROU M8 X1,25 U5588 6.8 ZN	MUTTER M8 X1,25 U5588 6.8 ZN	TUERCA M8 X1,25 U5588 6.8 ZN
14	G16013990R	AGGANCI0 LEVA TENDIMOLLA	LEVER HITCH SPRINGTIGHTNER			
15	G16071671R	BRACCIO SUPPORTO ERPICE	HARROW SUPPORT ARM			
16	F01220033R	DADO M10X1,5 D980 8ZN	NUT M10X1,5 D980 8ZN	ECROU M10X1,5 D980 8ZN	MUTTER M10X1,5 D980 8ZN	TUERCA M10X1,5 D980 8ZN
17	G16075470R	PIASTRA ATTACCO COPRISEME	SEEDCOVER PLATE			
18	G16075760R	SCONTRO 90X 40-15 2F11,5 52	PLATE 90X 40-15 2F11,5 52			
19	G16240780R	PIASTRINA MOLLA COPRISEME	PLATE SEED COVER SPRING	PLAQUETTE RESSORT COUVRE-GRAIN	PLZTTCHEN SAMENABDECKFEDER	PLAQUETA MUELLE CUBRESEMILLAS
20	G18904710R	MOLLA COPRISEME 2 PUNTE D.9	SEED COVER SPRING 2 TIPS D.9	RESS.COUVRE GRAIN 2 POIN.D.9		CUBRESEMILLAS 2 PUNTAS D.9
21	F20120348R	PUNTALE Q.40 NERO	SQUARE TIP 40 BLACK			
22	F20110705R	CAV.Q.B=40 M=10X1,5 L=62	U BOLT Q.B=40 M=10X1,5 L=62	CAVALIER ZN	BSGELBOLZEN ZN	PERNO EN U ZN
23	G16213980R	TUBO Q.40X 4X1900	SQUARE TUBE 40X4X1900			
24	G16019150R	TUBO Q. 40X 4X2100	TUBE Q. 40X 3X2100			
25	F01020118R	VITE M10X1,5X60 U5737 8.8ZN	SCR. M10X1,5X60 U5737 8.8ZN	VIS 10X60 5737 8.G ZN	SCHRAUBE 10X60 5737 8.G ZN	TORNILLO 10X60 5737 8.G ZN
26	F01020125R	VITE M10X1,5X75 U5737 8.8ZN	SCR. M10X1,5X75 U5737 8.8ZN	VIS M10X1,5X75 U5737 8.8ZN	SCHRAU. M10X1,5X78 U5737 8.8ZN	TORN. M10X1,5X75 U5737 8.8ZN
27	F01020135R	VITE M10X1,5X110 U5737 8.8ZN	SCR. M10X1,5X110 U5737 8.8ZN	VIS M 10X110	SCHRAUBE M 10X110	TORNILLO M 10X110
28	G16074370R	SUPPORTO BRACCIO ERPICE	HARROW ARM SUPPORT			
29	F01020476R	VITE M10X1,5X30 U5739 8.8ZN	SCR. M10X1,5X30 U5739 8.8ZN	VIS M10X1,5X30 U5739 8.8 ZN	SCHRAUBE M10X1,5X30U5739 8.8ZN	TORNIL.M10X1,5X30 U5739 8.8 ZN
30	G16074580R	SCONTRO 135X 40- 6 3F11 51-46	PLATE135X40-6 3HOLES11 51-46			
31	F01230048R	DADO M10X1,5 D982 8ZN	NUT M10X1,5 D982 8ZN	ECR.AUTO-FREIN.M10X1,5 D982 ZN	SICHERUNGSMUTT.M10X1,5 D982 ZN	TUERCA SEGURID.M10X1,5 D982 ZN

TRAILED VERSION

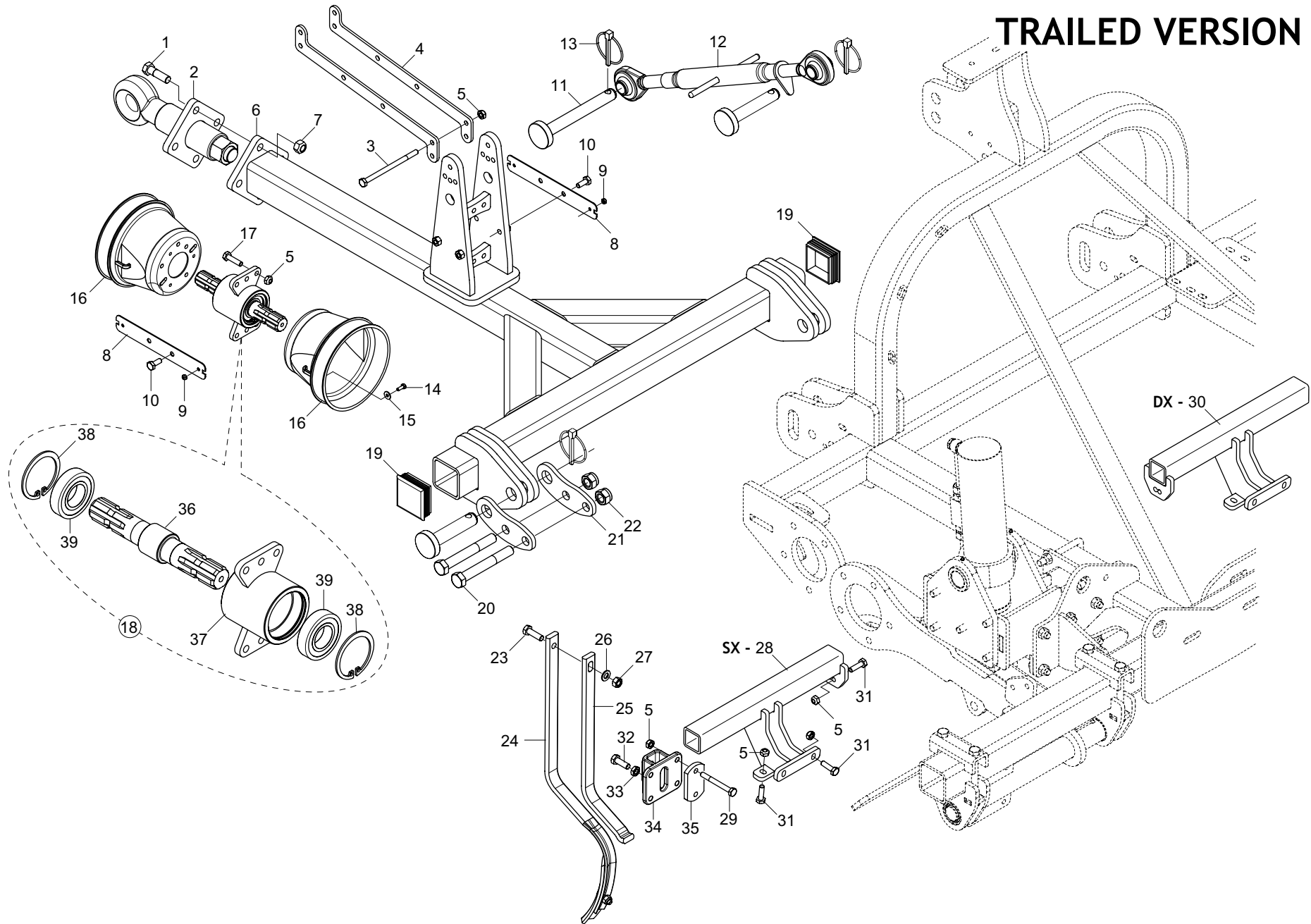

**KIT TRAINO - TIMONE
PULL HITCH KIT - DRAWBAR**

TAV. 270

Pos.	Cod.	Descrizione	Description	Description	Benennung	Description
1	F01020254R	VITE M16X2X55 U5737 10.9ZD	SCR. M16X2X55 U5737 10.9ZD			
2	G16074240R	GANCIO DI TRAINO	PULL HOOK			
3	F01020141R	VITE M10X1,5X160 U5737 8.8ZN	SCR. M10X1,5X160 U5737 8.8ZN	VIS M 10X160	SCHRAUBE M 10X160	TORNILLO M 10X160
4	G16070580R	LAMA GUIDA TUBI	BLADE GUIDE TUBES			
5	F01220033R	DADO M10X1,5 D980 8ZN	NUT M10X1,5 D980 8ZN	ECROU M10X1,5 D980 8ZN	MUTTER M10X1,5 D980 8ZN	TUERCA M10X1,5 D980 8ZN
6	G16074162R	TIMONE	RUDDER			
7	F01230085R	DADO M16X2 D982 10ZN	NUT M16X2 D982 10ZN	ECROU M16X2 D982 10ZN	MUTTER M16X2 D982 10ZN	TUERCA M16X2 D982 10ZN
8	G16073880R	STAFFA SUPP.PROTEZ.PTO	BAR PROTECT.PTO SUPPORT			
9	F01220011R	DADO M6X1 D980 8ZN	NUT M6X1 D980 8ZN	ECROU M6X1 D980 8 ZN	MUTTER M6X1 D980 8 ZN	TUERCA M6X1 D980 8 ZN
10	F01020472R	VITE M10X1,5X25 U5739 8.8ZN	SCR. M10X1,5X25 U5739 8.8ZN	VIS M10X1,5X25 U5739 8.8 ZN	SCHRAUBE M10X1,5X25 U5739 8.8	TORNILLO 10X25 U5739 8.8 ZN
11	F20100134R	PERNO D25 L190 C43 TEST.D60 ZN	BOLT D25 L190 C43 ZN			
12	F02450023R	MART M.L= 780 L= 550 D=25,4 ZG	TIE-ROD L=780 L= 550 D=25,4 ZG			
13	F02200507R	SPINAA SCATTO D 9 B 83	SNAP PIN D9 B 83 ZN	FICHE A DETENTE D9 B 83 ZN	EINRASTSTIFT D9 B 83 ZN	CLAVIJA DE MUELLE D9 B 83 ZN
14	F01020403R	VITE M6X1X16 U5739 8.8ZN	SCR. M6X1X16 U5739 8.8ZN	VIS M6X1X16 U5739 8.8 ZN	SCHRAUBE M6X1X16 U5739 8.8 ZN	TORNILLO M6X1X16 U5739 8.8 ZN
15	F01420036R	ROS.M6 6,4X 18X1,5 U6593 ZN	WASHER M6 6,4X 18X1,5 U6593 ZN	RONDELLE M6 6,4X18X1,5 U6593ZN	SCHIBEN M6 6,4X18X1,5U6593 ZN	ARANDELA M6 6,4X18X1,5U6593ZN
16	F05150403R	CUFFIA PROTEZ.CARDANO X GRUPPO	POWER TAKE-OFF PROTECTION HOUS	PROTECTEUR PRISE DE PUISSANCE	SCHUTZKASTEN KRAFTABTRIEB	ENVOLTURA PROTECCI N T. DE P.
17	F01020483R	VITE M10X1,5X40 U5739 10.9ZD	SCR. M10X1,5X40 U5739 10.9ZD	VIS M10X1,5X40 U5739 10.9 ZD	SCHRA.M10X1,5X40 U5739 10.9 ZD	TORN. M10X1,5X40 U5739 10.9 ZD
18	G16073890R	RINVIO PTO COMPL	PTO COMPLETE TRANSMISSION			
19	F05100156R	TAPPO PER TUBO 70X70	PLASTIC CAP X PIPE 70X70 TK.5	BOUCHON 70X 70	ROHRKOPFSTOPFEN 70X 70	TAPON 70X 70
20	F01020317R	VITE M20X2,5X150 U5737 8.8ZN	SCR. M20X2,5X150 U5737 8.8ZN	VIS M20X2,5X150 U5737 8.8ZN	SCHRAU.M20X2,5X150 U5737 8.8ZN	TORN. M20X2,5X150 U5737 8.8ZN
21	G16073921R	LAMA ATTACCO TIMONE	DRAWBAR HITCH BLADE			
22	F01230131R	DADO M20X2,5 D982 6ZN	NUT M20X2,5 D982 6ZN	ECROU M20X,5 D982 6ZN	MUTTER M20X2,5 D982 6ZN	TUERCA M20X2,5 D982 6ZN
23	F01020528R	VITE M12X1,75X40 U5739 10.9ZN	BOLT M12X1,75X40 U5739 10.9ZN	VIS M12X1,75X40 U5739 10.9 ZN	SCHR.M12X1,75X40 U5739 10.9 ZN	TORN.M12X1,75X40 U5739 10.9 ZN
24	G67002019R	ROMPIRACCIA	TRACEBREAKER	BRIS. DE TRACES	SPURMESSER	ROMPEHUELLA
25	G67002020R	RINFORZO ROMPIRACCIA	ROWBRAKER REINFORC.	RENFORT EFFACEUR DE TRACES	VERST-RKUNG SPURLOCKERERZINKEN	REFUERZO ROMPETRAZAS
26	F01410076R	ROS.M12 13X 24X2,5 U6592 ZN	WASHER 12 13X 24X2,5 U6592 ZN	RONDEL. M12 13X24X2,5 U6592 ZN	SCHIEBE M12 13X24X2,5 U6592 ZN	ARANDELA M12 13 X24X2,5 ZN
27	F01200293R	DADO M12X1,75 U5588 CL8 ZN	NUT M12X1,75 U5588 6S ZN	ECROU M12X1,75 U5588 6S ZN	MUTTER M12X1,75 U5588 6S ZN	TUERCA M12X1,75 U5588 6S ZN
28	G16076160R	SUPPORTO ROMPIRACCIA SX	ROWBREAKER SUPPORT LEFT			
29	F01020132R	VITE M10X1,5X90 U5737 10.9ZD	SCREW M10X1,5X90 U5737 10.9ZD	VIS M10X1,5X90 U5737 10.9ZD	SCHRAU.M10X1,5X90 U5737 10.9ZD	TORN. M10X1,5X90 U5737 10.9ZD
30	G16076170R	SUPPORTO ROMPIRACCIA DX	ROWBREAKER SUPPORT RIGHT			
31	F01020479R	VITE M10X1,5X35 U5739 8.8ZN	SCR. M10X1,5X35 U5739 8.8ZN	VIS M10X1,5X35 U5739 8.8 ZN	SCHR. M10X1,5X35 U5739 8.8 ZN	TORN. M10X1,5X35 U5739 8.8 ZN
32	F01020512R	VITE M12X1,75X35 U5739 8.8ZN	SCR. M12X1,75X35 U5739 8.8ZN	VIS M12X1,75X35 5739 8.8 ZN	SCHR. M12X1,75X35 5739 8.8 ZN	TORN. M12X1,75X35 5739 8.8 ZN
33	F01200421R	DADO M12X1,75 U5589 CL8 ZN6SZN	NUT M12X1,75 U5589 6SZN	ECROU M12	MUTTER M12	DADO M12
34	G19204220R	SUPPORTO ROMPIRACCIA	WIPEMARK SUPPORT			
35	G16019090R	SCONTRO 90 X50 -10 2F11 62	STRIKER 90 X50 -10 2F11 62	BUTEE 90 X50 -10 2F11 62	ANSCHLAG 90 X50 -10 2F11 62	ELEMENTO DE EMPALME 90 X50 -10
36	G16050610R	PRESA DI POTENZA ZN	POWER PRESS ZN			
37	G16073900R	SUPPORTO CUSCINETTO PTO	PTO BEARING SUPPORT			
38	F02050403R	ANELLO E. DI 72X 2,5 U7437 C7	SEEGER RING E.72X2,5 U7437 C70	SEEGER E. 72X 2,5 U7437 C70	SEEGERING E. 72X 2,5 U7437 C70	ANILLO E. 72X 2,5 U7437 C70
39	F04010178R	CUSC.D35 D72 B17 6207 2RS1 EX	BEAR.D35 D72 B17 6207 2RS1 EX	ROULEM. D35 D72 B17 6207 2RS1	LAGER D35 D72 B17 6207 2RS1	COJINETE D35 D72 6207 2RS1

TRAILED VERSION

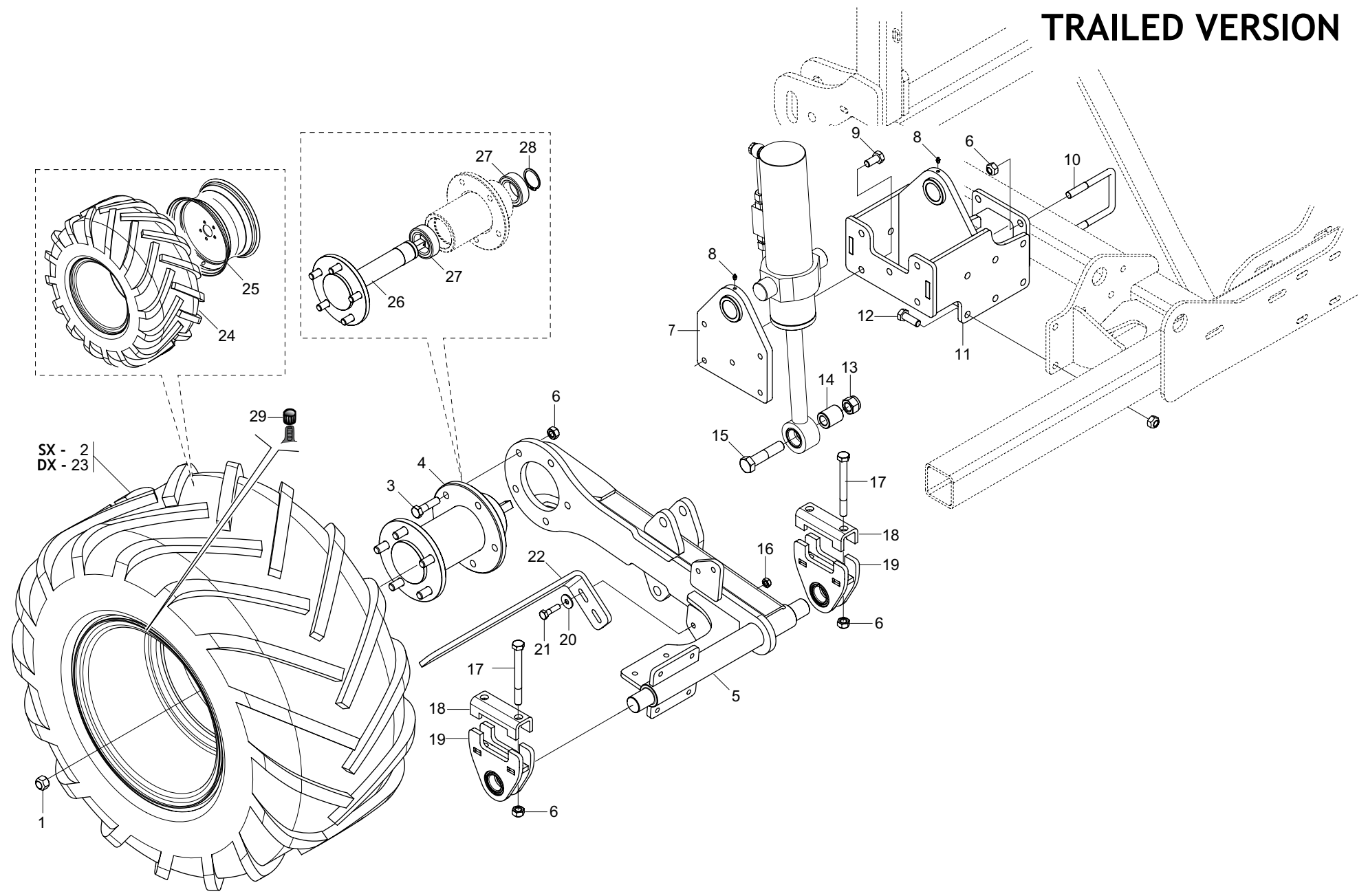

SX - 2
DX - 23

**KIT TRAINO - RUOTA DESTRA
PULL HITCH KIT - RIGHT WHEEL**

TAV. 280

Pos.	Cod.	Descrizione	Description	Description	Benennung	Descripcion
1	F01250046R	DADO COLON. 16X1,5 ZN	NUT STUD M16X 1.5 ZN	ECROU M16X1,5 COLONNETTE ZN	SCHRAUBBOLZENMUTTER M16X1,5 ZN	TUERCA M16X1,5 COLUMNNA ZN
2	F06120282R	RUOTA 31X15.5-15 SX	WHEEL 31X15.5-15 SX			
3	F01020201R	VITE M14X2X55 U5737 8.8ZN	SCR. M14X2X55 U5737 8.8ZN	VIS M 14X55	SCHRAUBE M 14X55	TORNILLO M 14X55
4	G16075670R	MOZZO RUOTA COMPL.	WHEEL HUB			
5	G16074650R	BRACCIO SOLL.CARRELLO	CARRIAGE LIFTING ARM			
6	F01220255R	DADO M14X2 D980 8ZN	NUT M14X2 D980 8ZN	ECROU M14X2 D980 8 ZN	MUTTER M14X2 D980 8 ZN	TUERCA M14X2 D980 8 ZN
7	G16075160R	SUPPORTO ESTERNO CILINDRO	EXTERNAL SUPPORT CILINDER			
8	F01100011R	ING.M 6X1 7663-A 9SMNPB28 ZN	GREASE NIPPLE M6X1 7663-A ZN	GRAISS. A BILLE M6X1 7663A ZN	SCHMIERBUECHE M6X1 7663-A ZN	ENGRAS. DE ESFE. M6X1 7663-AZN
9	F01020540R	VITE M14X2X30 U5739 8.8ZN	SCR. M14X2X30 U5739 8.8ZN	VIS M14X2X30 U5739 8.8ZN	SCHRAUBE M14X2X30 U5739 8.8ZN	TORNILLO M14X2X30 U5739 8.8ZN
10	F20110770R	CAV.Q.B=80 M=14X2 L=119	U BOLT Q,B=80 M=14X2 L=119	BRIDE U M14X2X50 96X119 ZN	ANSCHLANG U M14X2X50 96X119 ZN	EL.DE EMPALME M14X2X50 96X119
11	G16075080R	SUPPORTO INTERNO CILINDRO	INNER SUPPORT CILINDER			
12	F01020544R	VITE M14X2X40 U5739 8.8ZN	SCR. M14X2X40 U5739 8.8ZN	VIS M14X2X40 U5739 8.8ZN	SCHR.M14X2X40 U5739 8.8ZN	TOR.M14X2X40 U5739 8.8ZN
13	F01230131R	DADO M20X2,5 D982 6ZN	NUT M20X2,5 D982 6ZN	ECROU M20X,5 D982 6ZN	MUTTER M20X2,5 D982 6ZN	TUERCA M20X2,5 D982 6ZN
14	G18802680R	BOCCOLA 20,5X35X40,5 ZN	BUSHING 20,5X35X40,5 GALVA	BOITE 20,5X35X40,5 ZN	BSCHSE 20,5X35X40,5 ZN	CASQUILLO 20,5X35X40,5 ZN
15	F01020325R	VITE M20X2,5X90 U5737 10.9ZD	SCR. M20X2,5X90 U5737 10.9ZD	VIS M20X 2,5X 90 U5737 10.9 ZD	SCH.M20X 2,5X 90 U5737 10.9 ZD	TOR.M20X 2,5X 90 U5737 10.9 ZD
16	F01220033R	DADO M10X1,5 D980 8ZN	NUT M10X1,5 D980 8ZN	ECROU M10X1,5 D980 8ZN	MUTTER M10X1,5 D980 8ZN	TUERCA M10X1,5 D980 8ZN
17	F01020221R	VITE M14X2X140 U5737 8.8BR	SCR. M14X2X140 U5737 8.8BR	VIS M 14 X140 5737 8.G	SCHRAUBE M 14 X140 5737 8.G	TORNILLO M 14 X140 5737 8.G
18	G36200241R	SCONTRO U 80	FLANGE U 80	BRIDE U 80	ANSCHLAG U 80	ELEMENTO DE EMPALME U 80
19	G16075600R	SUPPORTO ASSE	AXLE SUPPORT			
20	F01420060R	ROS.M10 10,5X 30X2,5 U6593 ZG	GALV.WASHER 10,5X30X2,5 U6593	RONDELLE 10,5X30	SCHEIBE 10,5X30	ARANDELA 10,5X30
21	F01020110R	VITE M10X1,5X40 U5737 8.8ZN	SCR. M10X1,5X40 U5737 8.8ZN	VIS M 10X40	SCHRAUBE M 10X40	TORNILLO M 10X40
22	G17932320R	LAMA RASCHIATERRA	SOILSCRAPER BLADE			
23	F06120283R	RUOTA 31X15.5-15 DX	WHEEL 31X15.5-15 RIGHT			
24	F06120162R	COPERTURA 26X12.00-12	TYRE 26X12.00 - 12			
25	F06120204R	CERCHIO K12 S 384 5 FORI	CIRCLE K12 S 384 5 HOLES			
26	G17931791R	MONT.ASSE RUOTA	WHEEL AXLE ASS.BLY			
27	F04010347R	CUSC.D50 D80 B23 63010 2RS1	BEARING D50 D80 B23 63010 2RS1	PALIER D50 D80 B23 63010 2RS1	LAGER D50 D80 B23 63010 2RS1	COJINET.D50 D80 B23 63010 2RS1
28	F02050203R	ANELLO E. DE 50X 2 U7435 C70	SEEGER RING D50X2 U7435 C70	ANEL SEEGER D50X2 U7435 C70	SEEGER RING D50X2 U7435 C70	ANILLO SEEGER D50X2 U7435 C70
29	F05050025R	CAPPELOTTO PROTEZ. X VALV.PVC	PROTECTION CAP PVC X VALVA	CAPUCHON PROTECION PVC X VALVA	SCHUTZKAPPE PVC X VENTIL	TAPA PROTECION PVC X VALVA

TAV. 290

TRAILED VERSION

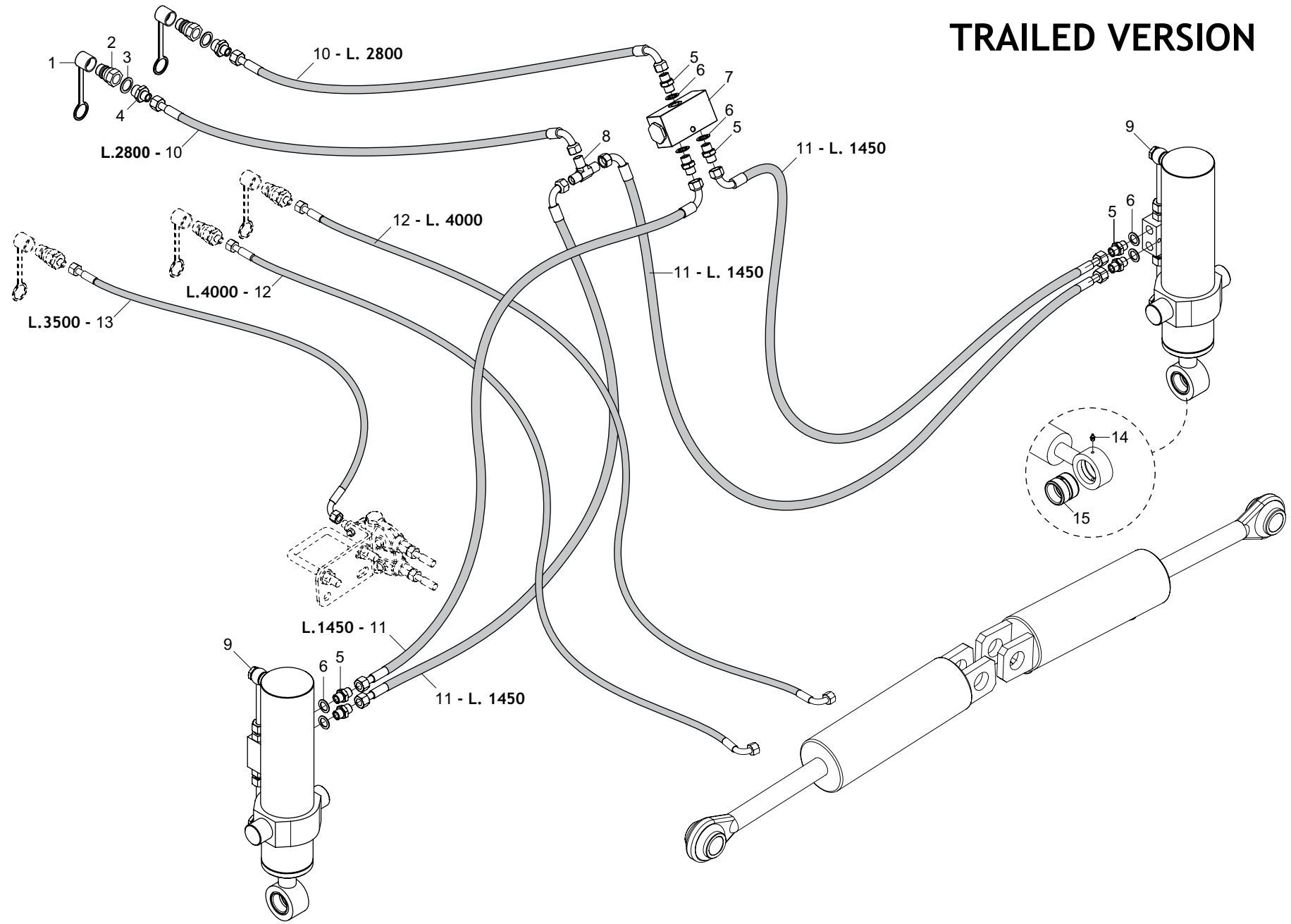

**KIT TRAINO - IMPIANTO OLEODINAMICO
PULL HITCH KIT - HYDRAULIC SYSTEM**

TAV. 290

Pos.	Cod.	Descrizione	Description	Description	Benennung	Descripcion
1	F05150325R	CAPPUC.F X INN.M RAP.1 2 ROSS	COVER CONNECT F 1 2 RED	COUVERCLE CONNEXION F 1 2 ROSE	DECKEL W 1 2 SCHNELLKUPP. ROT	PAC PROTECCION F 1 2 ROJO
2	F03150935R	INNESTO RAP.MASCH.1 2 A VALV.	QUICK CONNECT MALE CONE 1 2	CONNEXION RAPIDE MALE CONE 1 2	SCHNELLKUPP.GEWINDE KONISC 1 2	ACOPLAMIENT.RAP.MACHO CONO 1 2
3	F03151237R	ROS. 21 X27X1,5 RAME -1 2	COPPER WASHER 21X27X1,5 1 2	RONDELLE CUIVRE 21X27X1,5 1 2	SCHEIBE KUPFER 21X27X1,5 1 2	ARANDELA COBRE 21X27X1,5 1 2
4	F03150222R	NIPPLO MM CIL-CIL 1 2-3 8 ZG	NIPPLE M-M CYL-CYL 1 2-3 8 ZG	NIPPLE H-H CIL-CIL 1 2-3 8 ZG	NIPPEL M-M CIL-CIL 1 2-3 8 ZG	NIPLE H-H CIL-CIL 1 2-3 8 ZG
5	F03150321R	NIPPLO MM CIL-CIL 3 8-3 8 ZG	NIPPLE MM CIL-CIL 3 8-3 8 ZN	NIPPLE MM CIL-CIL 3 8-3 8 ZN	NIPPLEZYL MM 3 8-3 8 ZN	NIPLE MM CIL-CIL 3 8-3 8 ZN
6	F03100023R	ROS. 17 X23X1,5 RAME -3 8	WASHER 17X23X1,5 RAME -3 8	RONDELLE 17X23X1,5 RAME -3 8	SCHEIBE 17X23X1,5 RAME -3 8	ARAN. 17 X23X1,5 RAME -3 8
7	F03151146R	DIVISORE FLUSSO RIUNIF.3 8-24	REUNITED FLOW DIVIDER 3 8-24	DIVISEUR FLUX UNIF. 3 8-24	FLUSSTEILER 3 8-24	DIVISOR FLUJO REUNIF.3 8-24
8	F03151220R	RACCORDO -T- MASCHIO 3 8 ZN	MALE T-UNION 3 8 ZN	RACCORD -T- MALE 3 8 ZN	ANSCHLUSSTSCK-T-GEWINDE 3 8 ZN	UNION -T-MACHO 3 8 ZN
9	G16075590R	CILINDRO CARRELLO	CARRIAGE CYLINDER			
10	G15317630R	TUBO 3 8 R2 F3 8-F3 8 L.2800	PIPE 3 8 R2 F3 8-F3 8 L.2800	TUBE 3 8 R2 F3 8-F3 8 L.2800	ROHR 3 8 R2 F3 8-F3 8 L.2800	TUBO 3 8 R2 F3 8-F3 8 L.2800
11	G16117780R	TUBO 3 8R2 CF3 8- F3 8 1450	PIPE 3 8R2 CF3 8-F3 8 1450			
12	G16012650R	TUBO R2 1 4 C-F L.4000	PIPE 1 4 R2 C-F 1 4 L.4000	TUBE 1 4 R2 C-F 1 4 L. 4000	ROHR 1 4 R2 C-F 1 4 L 4000	TUBO 1 4 R2 C-F 1 4 L.4000
13	G15210561R	TUBO 1 4R2 CF1 4- F1 4 3500	PIPE 1 4R2 CF1 4- F1 4 3500	TUBE 1 4R2 CF1 4- F1 4 3500	ROHR 1 4R2 CF1 4- F1 4 3500	TUBO 1 4R2 CF1 4- F1 4 3500
14	F01100011R	ING.M 6X1 7663-A 9SMNPB28 ZN	GREASE NIPPLE M6X1 7663-A ZN	GRAISS. A BILLE M6X1 7663A ZN	SCHMIERBUECHE M6X1 7663-A ZN	ENGRAS. DE ESFE. M6X1 7663-AZN
15	G15322860R	BOCCOLA BRACCIO L.40	BUSHING ARM L.40	BUSHING BRAS L.40	BUCHSE ARM L.40	CASQUILLO BRAZO L.40

Codice - Code	Descrizione - Description	Lunghezze Lengths		Classe - Size (A x B)	Tipo - Type (*)		Forcella - Yokes (**)					Forcella - Yokes Z6 (1"3/8)
		min.	max.		Z6 (1"3/8)	Z6 (1"3/4)	Z8 (32x38)	Z20 (1"3/4)	Z21 (1"3/8)			
① F08011711	CARD.B1 Z6-Z6 L700	700	960	B1 (22 x 54)	A	A	G58161015 (11)	F08011772 (13)	F08011742 (15)	F08011758 (18)	F08011767 (20)	G58161015 (11)
② F08011713	CARD.B1 Z8-Z6 L700	700	960	B1 (22 x 54)	A	A	G58161015 (11)	F08011772 (13)	F08011742 (15)	F08011758 (18)	F08011767 (20)	G58161015 (11)
③ F08011714	CARD.B1 Z20-Z6 L700	760	1020	B1 (22 x 54)	A	A	G58161015 (11)	F08011772 (13)	F08011742 (15)	F08011758 (18)	F08011767 (20)	G58161015 (11)
④ F08011715	CARD.B1 Z8-Z6 L900 R.LIB	915	1190	B1 (22 x 54)	A	B	G58161015 (11)	F08011772 (13)	F08011742 (15)	F08011758 (18)	F08011767 (20)	—
⑤ F08011716	CARD.B1 Z6-Z6 L900 R.LIB	915	1190	B1 (22 x 54)	A	B	G58161015 (11)	F08011772 (13)	F08011742 (15)	F08011758 (18)	F08011767 (20)	—
⑥ F08011719	CARD.B2 Z6-Z6 L900	900	1300	B2 (23,8 x 61,3)	A	A	—	—	—	—	—	—
⑦ F08011720	CARD.B3 Z8-Z6 L1300	1300	1775	B3 (27 x 74,6)	A	A	G58161016 (14)	—	F08011743 (16)	—	—	G58161016 (14)
⑧ F08011757	CARD.B1 Z20-Z6 L900 R.L	975	1250	B1 (22 x 54)	A	B	G58161015 (11)	F08011772 (13)	F08011742 (15)	F08011758 (18)	F08011767 (20)	—
⑨ F08011764	CARD.R4 Z20-Z6 L1381 OM-RL	1381		R4 (22 x 86)	C	B	F08011768 (12)	—	F08011766 (17)	F08011774 (19)	F08011773 (21)	—
⑩ F08011783	CARD.R4 Z6-Z6 L1565 OM-RL	1565		R4 (22 x 86)	C	B	F08011768 (12)	—	F08011766 (17)	F08011774 (19)	F08011773 (21)	—
⑩ F08011930	CARD.B3 Z6-Z6 L1200	1200	1700	B3 (27 x 70)	A	A	—	G58161016 (14)	F08011743 (16)	—	—	—

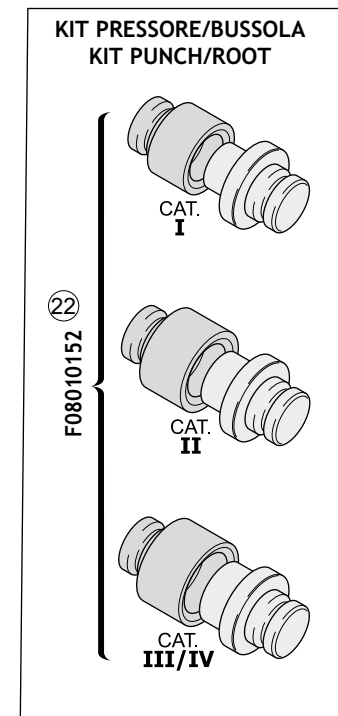
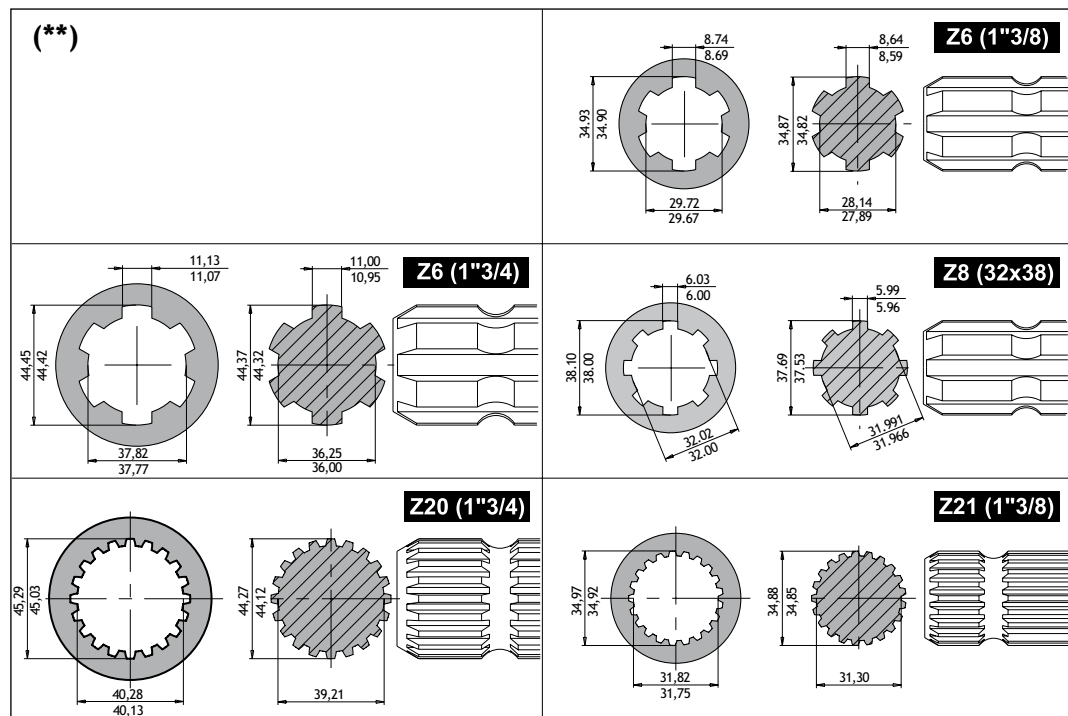
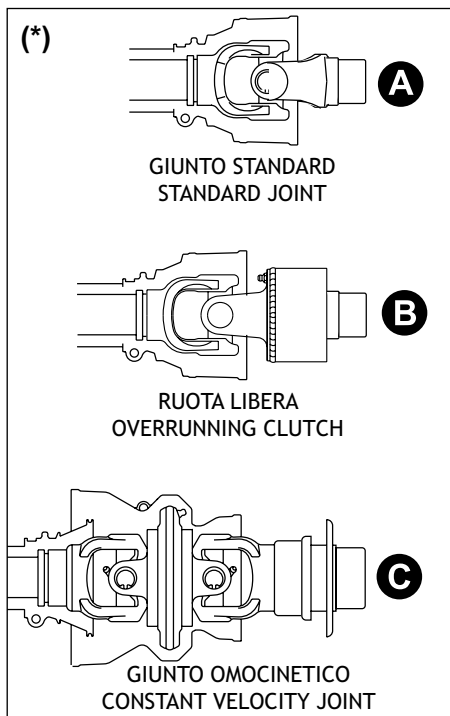

CARDANO CARDAN SHAFT

TAV. 300

Pos.	Cod.	Descrizione	Description	Description	Benennung	Descripcion
1	F08011711R	CARD. S10 0700F 112 112 1CAT	PTO SHAFT B1 Z6-Z6 L700			
2	F08011713R	CARD.B1 Z8-Z6 L700	PTO SHAFT B1 Z8-Z6 L700			
3	F08011714R	CARD.B1 Z20-Z6 L700	PTO SHAFT B1 Z20-Z6 L700			
4	F08011715R	CARD.B1 Z8-Z6 L900 R.LIB	CARD.B1 Z8-Z6 L900 FREE W.			
5	F08011716R	CARD.B1 Z6-Z6 L900 R.LIB	UNIV.JOINT B1 Z6-Z6 L900 R.LIB	CARD.B1 Z6-Z6 L900 R.LIB	KARDAN CE T100710 112 R12	CARDAN CE T100710 112 R12
6	F08011719R	CARD.B2 Z6-Z6 L900	UNIVERSAL JOINT 102 071 N T07	CARD. 102 071 N T07 T07 1 CAT	KARDAN 102 071 N T07 T07 1CAT	CARD N 102 071 N T07 T07 1CAT
7	F08011720R	CARD.B3 Z8-Z6 L1300	UNIV.JOINT B3 Z8-Z6 L1300			
8	F08011757R	CARD.B1 Z20-Z6 L900 R.L	UNIVERSAL JOINTB1 Z20-Z6 L900			
9	F08011764R	CARDANO OM 3 4Z20-RL Z6 L1381	CARD.R4 Z20-Z6 L1381 OM-RL			
10	F08011930R	CARD.B3 Z6-Z6 L1200	PTO SHAFT B3 Z6-Z6 L1200			
11	G58161015R	FORCELLA CARD.1 3 8 Z6 B1	CARD. FORK 1 3 8 Z6 B1			
12	F08011768R	FORCELLA CARD.1 3 8 Z6 R4	FORK 1 3 8 Z6 R4			
13	F08011772R	FORCELLA CARD.1 3 4 Z6 B1	YOKE 1 3 4 Z6 B1			
14	G58161016R	FORCELLA CARD.1 3 8 Z6 B3	CARD.FORK 1 3 8 Z6 B3			
15	F08011742R	FORCELLA CARD.32X38 Z8 B1	YOKE CARD.32X38 Z8 B1	FOURCHETTE CARDAN Z8 B1	GABEL KARDAN Z8 B1	HORQUILLA CARDAN Z8 B1
16	F08011743R	FORCELLA CARD.32X38 Z8 B3	YOKE CARD.32X38 Z8 B3			
17	F08011766R	FORCELLA CARD.32X38 Z8 R4	FORK 32X38 Z8 R4			
18	F08011758R	FORCELLA CARD.1 3 4 Z20 B1	CARD.FORK 1 3 4 Z20 B1			
19	F08011774R	FORCELLA CARD.1 3 4 Z20 R4	CARD. FORK 1 3 4 Z20 R4			
20	F08011767R	FORCELLA CARD.1 3 8 Z21 B1	CARD.FORK 1 3 8 Z21 B1			
21	F08011773R	FORCELLA CARD.1 3 8 Z21 R4	FORK 1 3 8 Z21 R4			
22	F08010152R	KIT PRESSORE BUSSOLA CAT I-IV	TOOLS FOR PTO YOKE CAT I-IV			
23	F08011783R	CARD.R4 Z6-Z6 L1565 OM-RL	UNIV. PTO SHAFT R4 Z6-Z6 L1210			

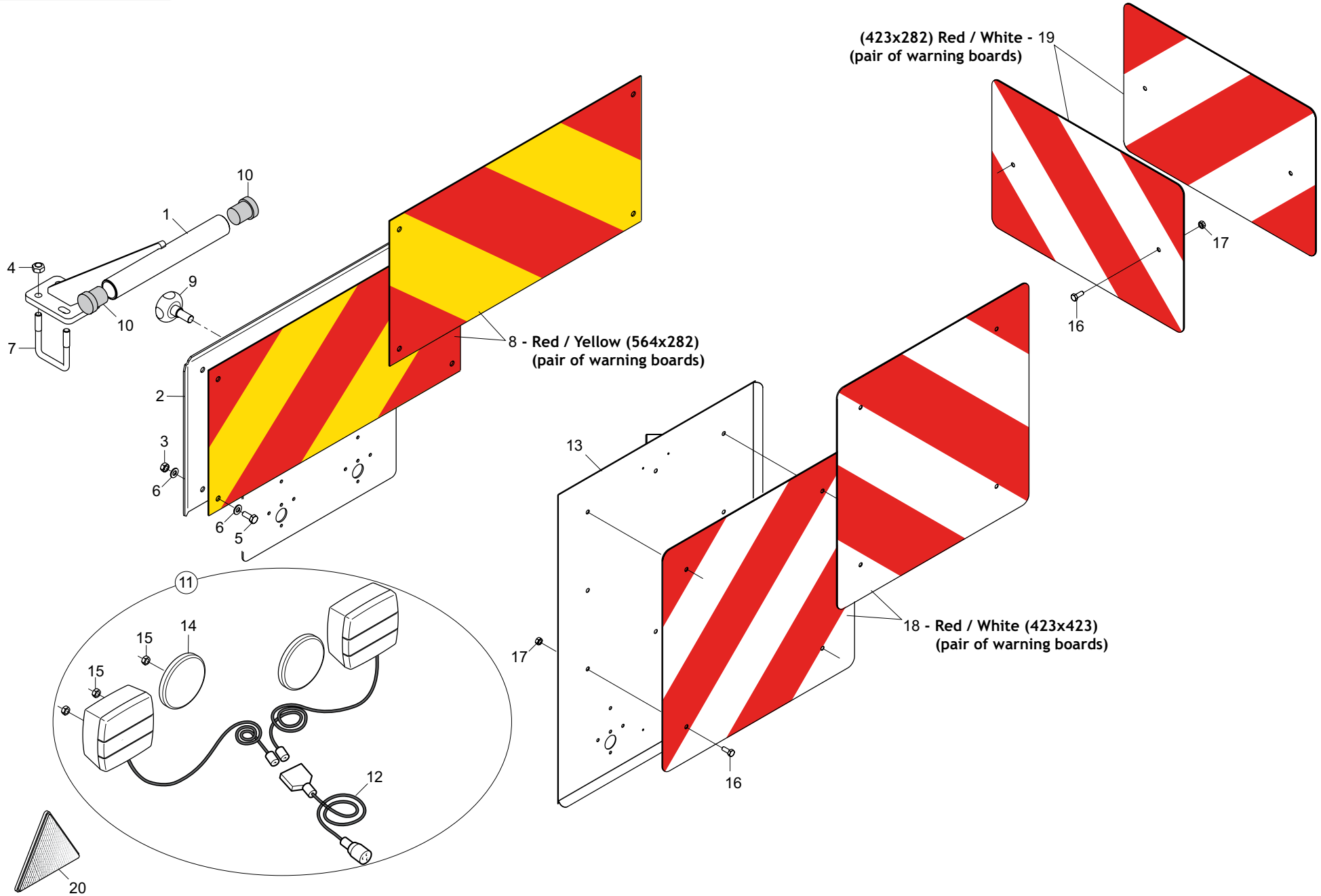

KIT LUCI E TABELLE DI INGOMBRO STRADALE LIGHTING KIT AND WARNING BOARDS

TAV. 330

Pos.	Cod.	Descrizione	Description	Description	Benennung	Descripcion
1	G17917040R	ASS.SUPPORTO FANALI	ASSY LAMP SUPPORT			
2	G16715250R	SUPPORTO TABELLA	SUPPORT	SUPPORT TABLEAU	TABELLENHALTERUNG	SOPORTE TABLA
3	F01220022R	DADO M8X1,25 D980 8ZN	NUT M8X1,25 D980 8ZN	ECROU M8X 1,25 D980 8 ZN	MUTTER M8X 1,25 D980 8 ZN	TUERCA M8X 1,25 D980 8 ZN
4	F01220033R	DADO M10X1,5 D980 8ZN	NUT M10X1,5 D980 8ZN	ECROU M10X1,5 D980 8ZN	MUTTER M10X1,5 D980 8ZN	TUERCA M10X1,5 D980 8ZN
5	F01020436R	VITE M8X1,25X20 U5739 8.8ZN	SCR. M8X1,25X20 U5739 8.8ZN	VIS M8X1,25X 20 U5739 8.8 ZN	SCHRAUBE M8X1,25X20U5739 8.8ZN	TORN. M8X1,25X20 U5739 8.8 ZN
6	F01410051R	ROS.M8 8,4X 17X1,6 U6592 ZN	WASHER M8 8,4X17X1,6 U6592 ZN	RONDELLE M8 8,4X17X1,6 ZN	SCHEIBE M8 8,4X17X1,6 U6592 ZN	ARANDELA M8 8,4X17X1,6 U6592ZN
7	F20110715R	CAV.Q.B=50 M=10X1,5 L=80	UBOLTSTRIKER Q.B=50M10X1,5L=80	BUTEE M10X 1,5X 30 61X 80 ZB	ANSCHLAG M10X 1,5X 30 61X 80	EL. DE EMPALME M10X 1,5X 30
8	F05010357R	N.2 PANNELLI CARICHI SPORGENTI	N.2 JUTTING LOAD PANELS	N.2 PANNEAUX CHARGES SAILLANT	N.2 TAFELN VORSRINGENDE LADUN	2 PANELES CARGADOS SALIENTES
9	F06220010R	VOLANTINO 8 LOBI M12X25	BOLT M12X25			
10	G67008050R	TERMINALE ROTONDO 28	ROUND END 28	PIECE TERMIN.RONDE 28	RUNDER ABSCHLUSS 28	TERMINAL REDONDO 28
11	G17912000R	KIT LUCI COMPLETO	KIT LIGHTS COMPL.	KIT ECLAIRAGE COMPL.	KIT LICHT KOMPL.	SET LUCES COMPL.
12	F05010080R	CABLAGGIO PER KIT LUCI	LIGHT WIRING HARNESS	CABLAGE KIT PHARES	VERKABELUNG LAMPENKIT	CABLEADO JUEGO LUCES
13	G17312780R	SUPPORTO PANNELLI	PANELS SUPPORT			
14	F05010221R	CATARIFRANGENTE TONDO D.80	ROUND REFLECTOR D.80			
15	F01220200R	DADO M5X0,8 D980 8ZN	NUT M5X0,8 D980 8ZN	ECROU M5X 0,8 D980 8 ZN	MUTTER M5X 0,8 D980 8 ZN	TUERCA M5X 0,8 D980 8 ZN
16	F01020403R	VITE M6X1X16 U5739 8.8ZN	SCR. M6X1X16 U5739 8.8ZN	VIS M6X1X16 U5739 8.8 ZN	SCHRAUBE M6X1X16 U5739 8.8 ZN	TORNILLO M6X1X16 U5739 8.8 ZN
17	F01220011R	DADO M6X1 D980 8ZN	NUT M6X1 D980 8ZN	ECROU M6X1 D980 8 ZN	MUTTER M6X1 D980 8 ZN	TUERCA M6X1 D980 8 ZN
18	F05010590R	PANNELLI CAR.SPORG.423X423	REFLECT PANELS 423X423			
19	F05010591R	PANNELLI CAR.SPORG.423X282	WARNING BOARD 423X282	PANNEAUX REFLECHISSANT 423X282	WARNTAFEL 423X282	ADVERTENCIA BORDO 423X282
20	F05010222R	CATARIFRANGENTE TRIANGOLARE	TRIANGULAR REFLECTOR	CATADIOPTRE TRIANGULAIRE	DREIECKIGE RSCKSTRAHLER	CATAFARO TRIANGULAR

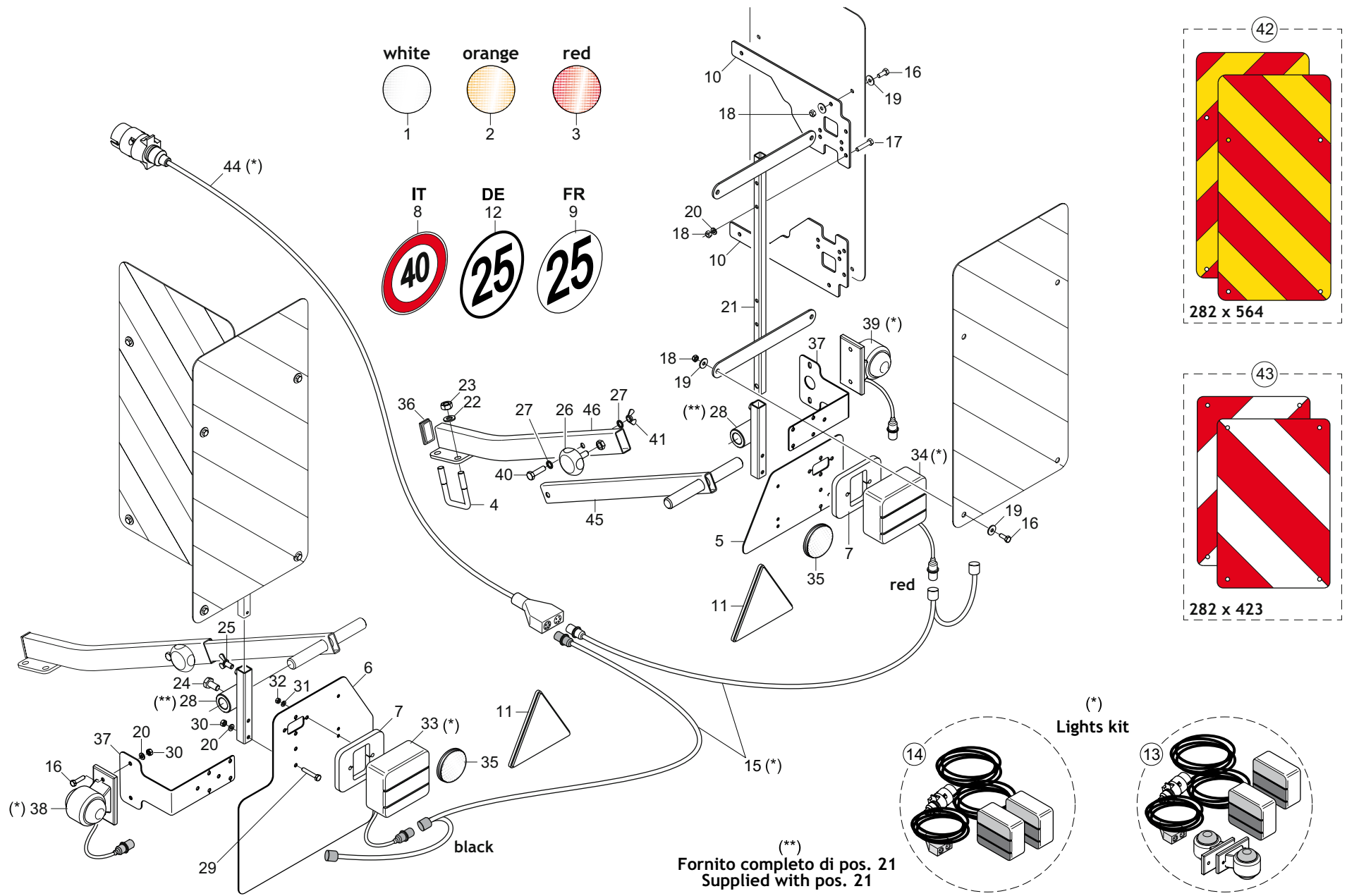

KIT LUCI E TABELLE DI INGOMBRO STRADALE LIGHTING KIT AND WARNING BOARDS

TAV. 310

Pos.	Cod.	Descrizione	Description	Description	Benennung	Descripcion
1	F05010818R	CATARIFR.TONDO D60 BIANCO	ROUND REFLECTOR D.60 WHITE			
2	F05010819R	CATARIFR.TONDO D60 GIALLO	ROUND REFLECTOR D.60 YELLOW	JAUNE R FLECTEUR ROUND	RUNDREFLEKTOR GELB D60	REFLECTOR REDONDO AMARILLO
3	F05010820R	CATARIFR.TONDO D60 ROSSO	ROUND REFLECTOR D.60 RED			
4	F20110705R	CAV.Q.B=40 M=10X1,5 L=62	U BOLT Q.B=40 M=10X1,5 L=62	CAVALIER ZN	BSGELBOLZEN ZN	PERNO EN U ZN
5	GA5210020R	PORTA LUCE	BACK LIGHT SUPPORT			
6	GA5210030R	PORTA TARGA	NUMBERPLATE SUPPORT			
7	GA5210040R	SUPPORTO LUCE	SUPPORT LIGHT			
8	F20030261R	ETICH. LIMITE VELOCITA 40	SPEED LIMIT 40 LABEL			
9	F20030258R	ETICH. LIMITE VELOCITA 25	SPEED LIMIT 25 LABEL	ETIQ. LIMITATION VITESSE 25	LABEL GRENZDREHZAH 25	ETIQ. LIMITE VELOCIDAD 25
10	M04700558R	SUPPORTO TABELLA INGOMBRO	LIGHT-CHART SUPPORT			
11	F05010222R	CATARIFRANGENTE TRIANGOLARE	TRIANGULAR REFLECTOR	CATADIOPTR TRIANGULAIRE	DREIECKIGE RSCKSTRAHLER	CATAFARO TRIANGULAR
12	F20030443R	ETICH. LIMITE VELOC.25 GERMAN	GERMANY SPEED LIMIT 25 LABEL			
13	F05010833R	KIT LUCI POST.STRAD.ECCEZ.	KIT REAR ROAD LIGHTS M.EXCEP.			
14	F05010822R	KIT FANALI DX-SX CON CAVO	KIT REAR ROAD LIGHTS MOUNTED			
15	F05200027R	CABLAGGIO ALI LUCI STRADALI	LATERAL STREET LIGHTS CABLE			
16	F01020404R	VITE M6X1X20 U5739 8.8ZN	SCREW M6X1X20 U5739 8.8ZN	VIS M6X1X20 U5739 8.8ZN	SCHRAUBE M6X1X20 U5739 8.8ZN	TORNILLO M6X1X20 U5739 8.8ZN
17	F01020408R	VITE M6X1X30 U5739 8.8ZN	SCR. M6X1X30 U5739 8.8ZN	VIS M 6X1X30	SCHRAUBE M 6X1X30	TORNILLO M 6X1X30
18	F01220011R	DADO M6X1 D980 8ZN	NUT M6X1 D980 8ZN	ECROU M6X1 D980 8 ZN	MUTTER M6X1 D980 8 ZN	TUERCA M6X1 D980 8 ZN
19	F01420036R	ROS.M6 6,4X 18X1,5 U6593 ZN	WASHER M6 6,4X 18X1,5 U6593 ZN	RONDELLE M6 6,4X18X1,5 U6593ZN	SCHEIBEN M6 6,4X18X1,5U6593 ZN	ARANDELA M6 6,4X18X1,5U6593ZN
20	F01420037R	ROS.M6 6,4X 24X1,5 U6593 ZN	WASHER M6 6,4X24X1,5 U6593 ZN			
21	G16612071R	TELAIO SUPP.TABELLE STRAD.	FRAME SUPPORT TABLE			
22	F01410064R	ROS.M10 10,5X 20X 2 U6592 ZN	WASHER M10 10,5X20X2 U6592 ZN	RONDEL. M10 10,5X20X2 U6592 ZN	SCHEIBE M10 10,5X20X2 U6592 ZN	ARANDEL.M10 10,5X20X2 U6592 ZN
23	F01200270R	DADO M10X1,5 U5588 CL8 ZN	NUT M10X1,5 U5588 6.8ZN	ECROU M10X 1,5 U5588 6.8 ZN	MUTTER M10X 1,5 U5588 6.8 ZN	TUERCA M10X 1,5 U5588 6.8 ZN
24	F01020470R	VITE M10X1,5X20 U5739 8.8ZN	SCR. M10X1,5X20 U5739 8.8ZN	VIS M10X1,5X20 U5739 8.8 ZN	SCHRAUBE M10X1,5X20 U5739 ZN	TORNILLOM10X1,5X20 U5739 8.8ZN
25	F01090215R	VITE M8X1,25X15 U5449 5.8ZN	SCR. M8X1,25X15 U5449 5.8ZN	VIS M8X1,25X15 U5449 5.8ZN	SCHRAU. M8X1,25X15 U5449 5.8ZN	TORN. M8X1,25X15 U5449 5.8ZN
26	F06220010R	VOLANTINO 8 LOBI M12X25	BOLT M12X25			
27	F01430059R	ROS.M8 8,4X 15X0,8 U8842J ZN	WASHER M8 8,4X15X0,8 U8842J ZN	ROND. M8 8,4X 15X0,8 U8842J ZN	SCHEIBE M8 8,4X15X0,8 U8842JZN	ARAND. M8 8,4X15X0,8 U8842J ZN
28	GA6910071R	SUPPORTO TAB.STRAD. S.MARIA	TABLE SUPPORT S.MARIA			
29	F01020040R	VITE M6X1X40 U5737 8.8ZN	SCR. M6X1X40 U5737 8.8ZN	VIS M6X1X40 U5737 8.8ZN	SCHRAU. M6X1X40 U5737 8.8ZN	TORNI. M6X1X40 U5737 8.8ZN
30	F01200232R	DADO M6X1 U5588 CL8 ZN	NUT M6X1 U5588 6.8ZN	ECROU 6 UNI 5588 6.8 ZN	MUTTER 6 UNI 5588 6.8 ZN	TUERCA 6 UNI 5588 6.8 ZN
31	F01410023R	RONDELLA D5 UNI 6592 ZN	WASHER M5 5,3X 10X 1 U6592			
32	F01200220R	DADO M5X0,8 U5588 CL8 ZN	NUT M5X0,8 U5588 6.8ZN	ECROU 5 UNI 5588 6.8 ZN	MUTTER 5 UNI 5588 6.8 ZN	TUERCA 5 UNI 5588 6.8 ZN
33	G67201083R	FANALE LUCE-FRENO-FRECCIA SX	LIGHT SX			
34	G67201082R	FANALE DX	STOP TABLE RIGHT			
35	F05010820R	CATARIFR.TONDO D60 ROSSO	ROUND REFLECTOR D.60 RED			
36	F05100215R	TAPPO PLT X TUBO 40X20 SP.3	PLUG PIPE 40X20 TK.3			
37	G17715130R	SUPPORTO LAT.CATADIOTRI	REFLECTOR LATERAL SUPPORT			
38	F05010346R	LUCE INGOMBRO ANTERIORE SX	FRONT LEFT LIGHT			
39	F05010345R	LUCE INGOMBRO ANTERIORE DX	FRONT LIGHT DX			
40	F01020445R	VITE M8X1,25X30 U5739 8.8ZN	SCR. M8X1,25X30 U5739 8.8ZN	VIS M 8X1,25X30 U5739 8.8 ZN	SCHRAU, M8X1,25X30 U5739 8.8ZN	TORN. M8X1,25X30 U5739 8.8 ZN
41	F01240024R	DADO M8X1,25 U5448 5.8ZN	NUT M8X1,25 U5448 5.8ZN	ECROU 8 UNI 5448 5.8 ZN	MUTTER 8 UNI 5448 5.8 ZN	TUERCA 8 UNI 5448 5.8 ZN
42	F05010816R	TABELLE 2 CAR.SPORGENTI IT	WARNING BOARDS 2 IT			
43	F05010817R	TABELLE 2 CAR.SPORGENTI FR-D	WARNING BOARDS 2 FR-DE	TABLEAUX 2 AVERTISSEM. FR-DE	BRETT 2 WARNUNG FR-DE	TABLAS 2 CAR.ADVERT. FR-DE
44	F05200026R	CABLAGGIO PRINCIPALE	MAIN CABLE			
45	G16019960R	SUPPORTO TABELLA MOBILE PINTA	MOBILE TABLE SUPPORT PINTA			
46	G16019940R	SUPPORTO TABELLA FISSA PINTA	FIXED TABLE SUPPORT PINTA			

**USATE SEMPRE RICAMBI ORIGINALI
ALWAYS USE ORIGINAL SPARE PARTS
IMMER DIE ORIGINAL-ERSATZTEILE VERWENDEN
EMPLOYEZ TOUJOURS LES PIECES DE RECHANGE ORIGINALES
UTILIZAR SIEMPRE REPUESTOS ORIGINALES**

GASPARDO

Servizio Assistenza Tecnica - After Sales Service

Servizio Ricambi - Spare Parts Service



maschio.com

DEALER:



MASCHIO GASPARDO SpA

Registered office & Production plant
Via Marcello, 73 - 35011 Campodarsego (Padova) - Italy
Tel. +39 049 9289810
Fax +39 049 9289900
info@maschio.com
www.maschionet.com

**MASCHIO GASPARDO SpA
Production plant**

Via Mussons, 7 - 33075 Morsano al Tagliamento (PN) - Italy
Tel. +39 0434 695410
Fax +39 0434 695425
info@gaspardo.it

MASCHIO DEUTSCHLAND GMBH

Äußere Nürnberger Straße 5
D - 91177 Thalmässing - Deutschland
Tel. +49 (0) 9173 79000
Fax +49 (0) 9173 790079
dialog@maschio.de
www.maschio.de

MASCHIO-GASPARDO North America

112 3rd Avenue East
Dewitt, IA 52742 - USA
Ph. +1 563 659 6400
Fax +1 563 659 6405
info@maschio.us

MASCHIO FRANCE Sarl

Rue Denis Papin ZA
F - 45240 La Ferté St. Aubin
France
Tel. +33 (0) 2.38.64.12.12
Fax +33 (0) 2.38.64.66.79
info@maschio.fr

MASCHIO-GASPARDO ROMANIA S.R.L.

Strada Înfrăţirii, F.N.
315100 Chisineu-Cris (Arad) -România
Tel. +40 257 307030
Fax +40 257 307040
info@maschio.ro

000 MASCHIO-GASPARDO РУССИЯ

Улица Пушкина, 117 Б
404130 Волжский
Волгоградская область
Тел. +7 8443 203100
факс. +7 8443 203101
info@maschio.ru

**MASCHIO-GASPARDO IBERICA
MASCHIO-GASPARDO POLAND
MASCHIO-GASPARDO UCRAINA
GASPARDO-MASCHIO TURCHIA
MASCHIO-GASPARDO CINA
MASCHIO-GASPARDO INDIA**