

MASCHIO GASPARDO S.p.A.

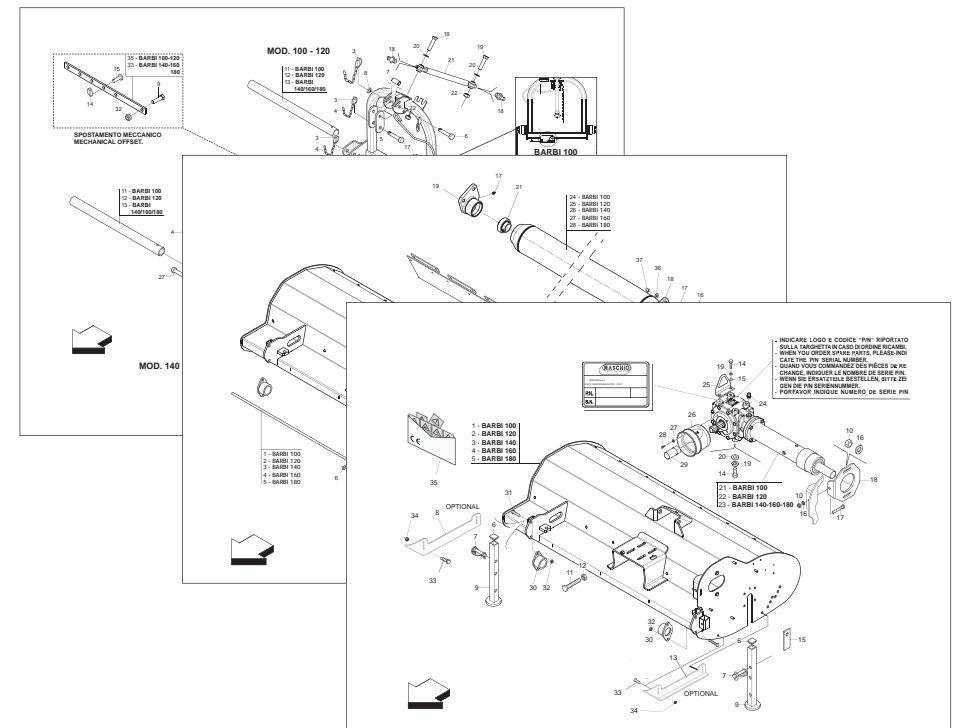

BARBI

Cod: F07011343 2015-11

- *) Valido per Paesi UE
- *) Valid for EU member countries
- *) Valable dans les Pays UE
- *) Gilt für EU-Mitgliedsländer
- *) Válido para Países UE

- IT PARTI DI RICAMBIO**
- EN SPARE PARTS**
- DE ERSATZTEILE**
- FR PIÈCES DÉTACHÉES**
- ES PIEZAS DE REPUESTO**

PARTI DI RICAMBIO

SPARE PARTS

ERSATZTEILE

PIECES DÉTACHÉES

RESPUESTOS

Le ordinazioni delle parti di ricambio vanno fatte presso i nostri concessionari di zona e devono essere sempre corredate dalle seguenti indicazioni:

- **Tipo, modello e numero di matricola dell'attrezzatura.** Tali dati sono stampigliati nell'apposita targhetta di cui è dotata ogni attrezzatura.

- **Numero di codice della parte richiesta** rilevabile dal catalogo ricambi.

- **Descrizione del particolare e quantità richiesta.**

- **Numero della tavola.**

- **Mezzo di trasporto.** Nel caso questa voce non sia specificata, la Ditta Costruttrice, pur dedicando a questo servizio una particolare cura, non risponde di eventuali ritardi di spedizione dovuti a cause di forza maggiore.

Le spese di trasporto si intendono sempre a carico del destinatario. La merce viaggia a rischio e pericolo del committente anche se venduta franco destino.

NOTA: Il termine **(Dx) Destro** o **(Sx) Sinistro** della macchina o di parti di essa, è inteso guardando la macchina dalla parte posteriore. Le eccezioni saranno indicate.

Orders must be transmitted through our area dealers and should always include the following indications:

- **Type, model and serial number of the machine.** *These data are punched on the data plate with which every implement is equipped.*

- **Code number of the required spare part.** *This will be found in the spare parts catalogue.*

- **Description of the part and required quantity.**

- **Table number.**

- **Means of dispatch.** *If this item is not indicated, the Manufacturer, while dedicating particular care to this service, shall not be held responsible for delays in delivery caused by cases of force majeure.*

Transport expenses shall always be at the consignee's charge. The goods travel at the purchaser's risk and peril even when sold ex destination.

NOTE: *The symbols (Dx) right and (Sx) left, concerning the machine or single parts of it, are referred, as in the figure, to a rear view of them. Exceptions will be indicated.*

Die Bestellungen müssen bei unseren Gebietshändlern aufgegeben werden. Bei der Bestellung sind stets die folgenden Angaben zu machen:

- **Typ, Modell und Serien-Nummer des Geräts.** Diese Daten stehen auf dem Typenschild, mit dem jedes Gerät versehen ist.

- **Artikel Nr. der erforderlichen Ersatzteile.** Diese stehen im Ersatzteil-Katalog.

- **Beschreibung des Ersatzteils und die erforderliche Stückzahl.**

- **Tafelnummer.**

- **Versandmittel.** Wenn dieser Punkt nicht spezifiziert wird, haftet die Herstellerfirma nicht für etwaigen Lieferverzug aufgrund höherer Gewalt, auch wenn er diesen Service besonders aufmerksam abwickelt.

Die Frachtkosten gehen dagegen immer zu Lasten des Empfängers. Die Ware reist auf Gefahr und Risiko des Auftraggebers, auch wenn frei Haus Verkauft vereinbart worden ist.

N.B.: Die Merkzeichen **(Dx) rechts** und **(Sx) links** betreffen eine rückwärtige Aussicht der Maschine oder Teile von ihr (siehe Bild). Ausnahmen werden gezeigt.

Les ordres doivent être effectués auprès de nos concessionnaires de zone en précisant les indications suivantes:

- **Type, modèle et numéro de série de la machine.** *Ces données sont gravées sur la plaque d'identification de chaque outil.*

- **Numéro de code de la pièce détachée** *indiqué sur le catalogue des pièces détachées.*

- **Description de la pièce et quantité requise.**

- **Numéro de plan.**

- **Moyen d'expédition.** *Si cette rubrique n'est pas indiquée, le Constructeur, bien que soucieux de ce service, ne répond pas des retards d'expédition pour des causes de force majeure.*

Les frais de transport sont toujours à la charge du destinataire. La marchandise voyage aux risques et périls de l'acheteur même si vendue franco de port.

N.B.: *Les références (Dx) droit et (Sx) gauche de la machine ou des parties de la même, est entendue, comme de la figure, en regardant la machine de derriere dans le sens de marche.*

Los pedidos han de efectuarse en nuestros concesionarios de zona y deben incluir siempre las siguientes indicaciones:

- **Tipo, modelo y número de matrícula del equipo.** Dichos datos están impresos en la relativa placa presente en el equipo.

- **Número de código de la parte requerida** presente en el catálogo respuestas.

- **Descripción de la pieza y cantidad requerida.**

- **Numero de ilustración.**

- **Medio de transporte.** En caso que este ítem no esté especificado, el Fabricante, aún prestando la debidas consideraciones para este aspecto, no responde por eventuales retardos de env'o debidos a causas de fuerza mayor.

Los gastos de transporte se consideraran siempre a cargo del destinatario. La mercadería viaja bajo riesgo y peligro del comprador, incluso cuando se vende franco destino.

N.B.: La referencia **(Dx) derecha** o **(Sx) izquierda** de la máquina o de sus componentes, se entiende, como en la figura, mirando la máquina por la parte trasera. Se indicarán las excepciones.

INDICE

<i>N° Tavola</i>	<i>Descrizione</i>	<i>Pagina</i>
TAV. 010	Telaio e moltiplicatore	4
TAV. 020	Gr. 3° punto.....	6
TAV. 030	Trasmissione - Gruppo rullo - Cofano	8
TAV. 040	Rotore	10
TAV. 050	Esploso Moltiplicatore	12
TAV. 060	Lamiera antiusura	14
TAV. 070	Supporti tabelle stradali	16
TAV. 080	Kit tabelle stradali G99600006.....	18
TAV. 090	Kit tabelle stradali G99600017	20
TAV. 100	Kit tabelle stradali G99600018.....	22
CARD.01	Albero cardanico	24
CARD.02	Albero cardanico Walterscheid (Optional).....	26

INDEX

<i>N° Table</i>	<i>Description</i>	<i>Page</i>
TAV. 010	Frame and Overdrive	4
TAV. 020	3rd-point.....	6
TAV. 030	Transmission - Roller Unit - Rear bonnet.....	8
TAV. 040	Rotor	10
TAV. 050	Gearbox exploded.....	12
TAV. 060	Double skin frame	14
TAV. 070	Road kit supports	16
TAV. 080	Road transport kit G99600006.....	18
TAV. 090	Road transport kit G99600017.....	20
TAV. 100	Road transport kit G99600018.....	22
CARD.01	Cardan shaft	24
CARD.02	Walterscheid cardan shaft (Optional).....	26

TAV. 010



- INDICARE LOGO E CODICE "P/N" RIPORTATO SULLA TARGHETTA IN CASO DI ORDINE RICAMBI.
 - WHEN YOU ORDER SPARE PARTS, PLEASE-INDICATE THE P/N SERIAL NUMBER.
 - QUAND VOUS COMMANDEZ DES PIÈCES DE RECHANGE, INDIQUER LE NOMBRE DE SERIE P/N.
 - WENN SIE ERSATZTEILE BESTELLEN, BITTE ZEIGEN DIE P/N SERIENNUMMER.
 - PORFAVOR INDIQUE NUMERO DE SERIE P/N

- 1 - BARBI 100
- 2 - BARBI 120
- 3 - BARBI 140
- 4 - BARBI 160
- 5 - BARBI 180

- 21 - BARBI 100
- 22 - BARBI 120
- 23 - BARBI 140-160-180

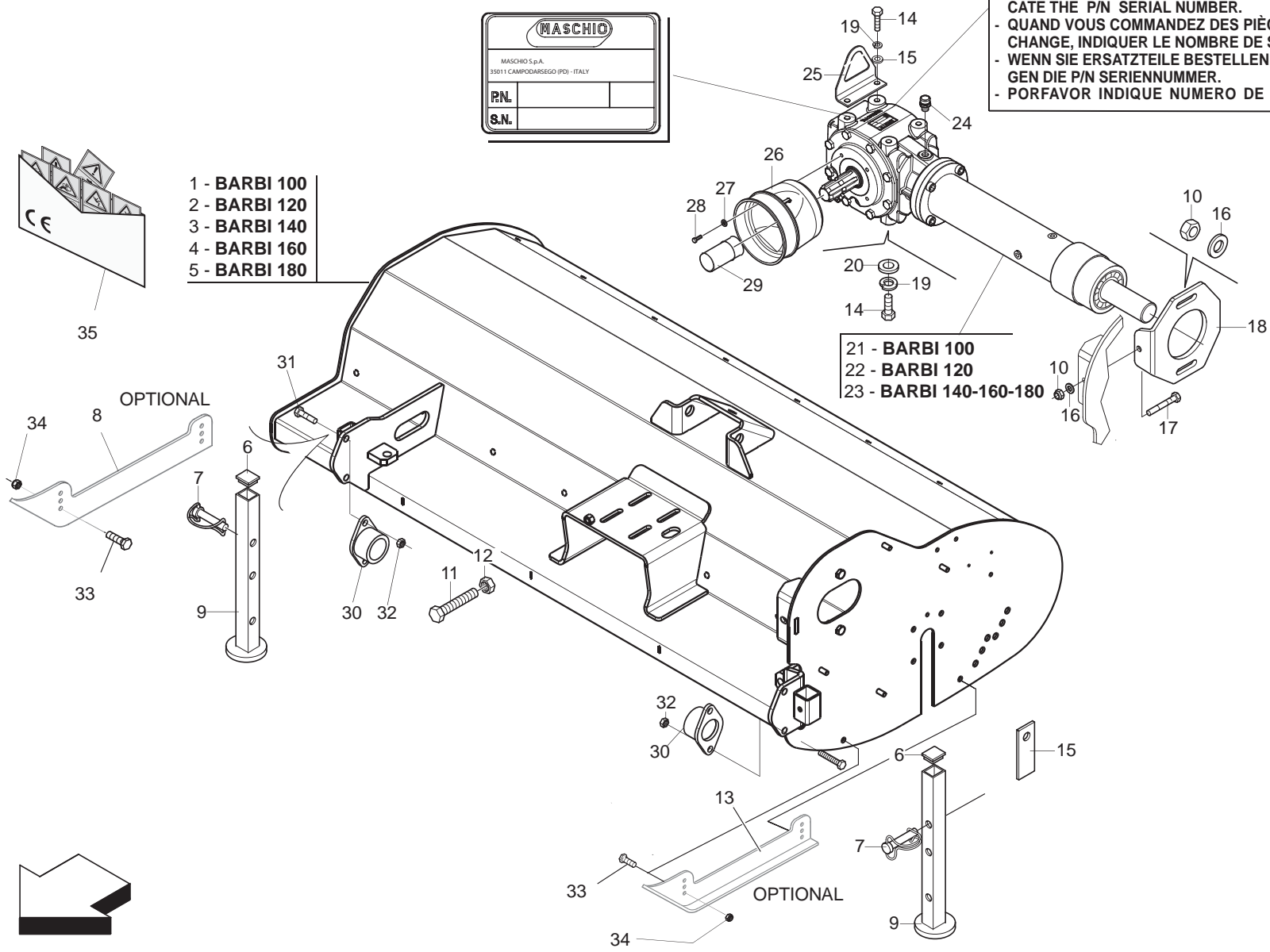

TELAIO E MOLTIPLICATORE / FRAME AND OVERDRIVE

TAV. 010

Pos.	Cod.	Descrizione	Description	Benennung	Description	Description
1	M33410701R	TELAIO CHIUSO	FRAME			
2	M33412701R	TELAIO CHIUSO	FRAME			
3	M33414701R	TELAIO CHIUSO	FRAME			
4	M33416701R	TELAIO CHIUSO	FRAME			
5	M33418701R	TELAIO CHIUSO	FRAME			
6	F05100025R	TAPPO AD ALETTE 35X35 PLT NERO	PLUG	BOUCHON FERMETURE	VERSCHLUSSPFROPFEN	TAPONCLAUSURA
7	F02200562R	SPINA SICUR.D. 8X70 ZN	SNAP PIN D.8X 70 ZN	FICHE EL. D.8X70 ZN	SCHERSTIFT D.8X 70 ZN	CLAVIJA D.8X 70 ZN
8	M30400536R	SLITTA LATO ESTERNO GF	SIDE PANEL SKID			
9	M56400922R	COMP. PIEDINO L=424,3	SUPPORT ASSEMBLY L=424,3	SUPPORT L=424,3	STANDER L=424,3	SOPORTE L=424,3
10	F01220047R	DADO M12X1,25 D980 8ZN	NUT M12X1,25 D980 8ZN	ECROU M12X1,25 D980 8 ZN	MUTTER M12X1,25 D980 8 ZN	TUERCA M12X1,25 D980 8 ZN
11	F01010298R	VITE M12X1,25X80 U5740 8.8ZN	SCR. M12X1,25X80 U5740 8.8ZN	VIS M12X1,25X80 U5740 8.8 ZN	SCHR.M12X1,25X 80 U5740 8.8 ZN	TORN.M12X1,25X 80 U5740 8.8ZN
12	F01200073R	DADO M12X1,25 U5587 CL8 ZN	NUT M12X1,25 U5587 6SZN	ECROU M12X1,25 U5587 6S ZN	MUTTER M12X1,25 U5587 6S ZN	TUERCA M12X1,25 U5587 6S ZN
13	M30400535R	SLITTA LATO TRASMISSIONE	TRANSMISSION SIDE SKID			
14	F01010283R	VITE M12X1,25X30 U5740 8.8ZN	SCR. M12X1,25X30 U5740 8.8ZN	VIS M 12X1,25X30	SCHRAUBE M 12X1,25X30	TORNILLO M 12X1,25X30
15	M33400514R	CHIUSURA LATERALE	REAR LATERAL PANEL	CAPOT ARRIERE LATERAL	HINTERE BLECH	PLANCHA LATERALE
16	F01410076R	ROS.M12 13X 24X2,5 U6592 ZN	WASHER 12 13X 24X2,5 U6592 ZN	RONDEL. M12 13X24X2,5 U6592 ZN	SCHEIBE M12 13X24X2,5 U6592 ZN	ARANDELA M12 13 X24X2,5 ZN
17	F01010296R	VITE M12X1,25X65 U5740 8.8BR	SCR. M12X1,25X65 U5740 8.8BR	VIS M12X1,25X65 U5740 8.8 ZN	SCHR.M12X1,25X 65 U5740 8.8 ZN	TORN.M12X1,25X 65 U5740 8.8 Z
18	T16005525R	SUPPORTO TENDICINGHIA	BELT STRETCHER	SUPPORT TENDEUR DE COURROIE	HALTERUNG	SOPORTE
19	F01480123R	ROS.G 12,5X22,9X 4 FLZNNC-240H	WASHER M12 ZGP EXTRA P.	RONDELLE M12 ZGP EXTRA P.	UNTERLEGSCHLEIBE M12 ZGP EXTRA	ARANDELA M12 ZGP EXTRA P.
20	F01500011R	ROS. 13 X35X5 D6340 C50 ZN	WASHER D. 12	RONDELLE D.12	SCHEIBE D.12	ARANDELA D.12
21	M22409205R	GRUPPO MOLTIPLICATORE 540 RPM	GR.MOLTIPL.540 RPM			
22	M22413205R	GRUPPO MOLTIPLICATORE 540 RPM	GR.MOLTIPL.540 RPM			
23	M22414205R	GRUPPO MOLTIPLICATORE 540 RPM	GEARBOX 540 RPM			
24	F03150718R	TAPPO 3 8 GAS CON SFIATO	GAS BREATHER PLUG 3 8	BOUCHON D HUILE SOUPIRAIL	OELENTLUEFTERSTOPFEN	TAPON ACEITE
25	T19005082R	STAFFA SOLLEVAMENTO	LIFTING STIRRUP	ETRIER DE RELEVAGE	HEBEBUEGEL	ESTRIBO LEVANTAMIENTO
26	F05150403R	CUFFIA PROTEZ.CARDANO X GRUPPO	POWER TAKE-OFF PROTECTION HOUS	PROTECTEUR PRISE DE PUISSANCE	SCHUTZKASTEN KRAFTABTRIEB	ENVOLTURA PROTECCI N.T. DE P.
27	F01410051R	ROS.M8 8,4X 17X1,6 U6592 ZN	WASHER M8 8,4X17X1,6 U6592 ZN	RONDELLE M8 8,4X17X1,6 ZN	SCHEIBE M8 8,4X17X1,6 U6592 ZN	ARANDELA M8 8,4X17X1,6 U6592ZN
28	F01020432R	VITE M8X1,25X16 U5739 8.8ZN	SCR. M8X1,25X16 U5739 8.8ZN	VIS M8 X1,25X16 U5739 8.8 ZN	SCHRAUBE M8X1,25X16U5739 8.8ZN	TORNILLO M8X1,25X16U5739 8.8ZN
29	G19002131R	PROTEZIONE P.D.P.	PDP GUARD			
30	M33400561R	SUPPORTO TUBO SCORRIMENTO	SLIDING ROD SUPPORT	SUPPORT TIGE DE GLISSEMENT	GLEITSTANGE HALTERUNG	SOPORTE BARRA DESLIZAMIENTO
31	F01010313R	VITE M14X1,5X30 U5740 8.8ZN	SCR. M14X1,5X30 U5740 8.8ZN	VIS M 14X1,5X30	SCHRAUBE M 14X1,5X30	TORNILLO M 14X1,5X30
32	F01220059R	DADO M14X1,5 D980 8ZN	NUT M14X1,5 D980 8ZN	ECROU M14X 1,5 D980 8 ZN	MUTTER M14X 1,5 D980 8 ZN	TUERCA M14X 1,5 D980 8 ZN
33	F01010283R	VITE M12X1,25X30 U5740 8.8ZN	SCR. M12X1,25X30 U5740 8.8ZN	VIS M 12X1,25X30	SCHRAUBE M 12X1,25X30	TORNILLO M 12X1,25X30
34	F01220047R	DADO M12X1,25 D980 8ZN	NUT M12X1,25 D980 8ZN	ECROU M12X1,25 D980 8 ZN	MUTTER M12X1,25 D980 8 ZN	TUERCA M12X1,25 D980 8 ZN
35	M33400572R	ETICHETTE BARBI	STICKERS BARBI			

TAV. 020

MOD. 100 - 120

DETTAGLIO MONTAGGIO ASSEMBLY DETAIL

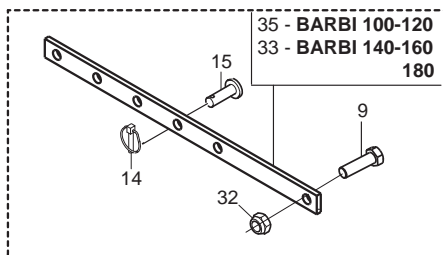

SPOSTAMENTO MECCANICO
MECHANICAL OFFSET.

- 11 - BARBI 100
- 12 - BARBI 120
- 13 - BARBI 140/160/180

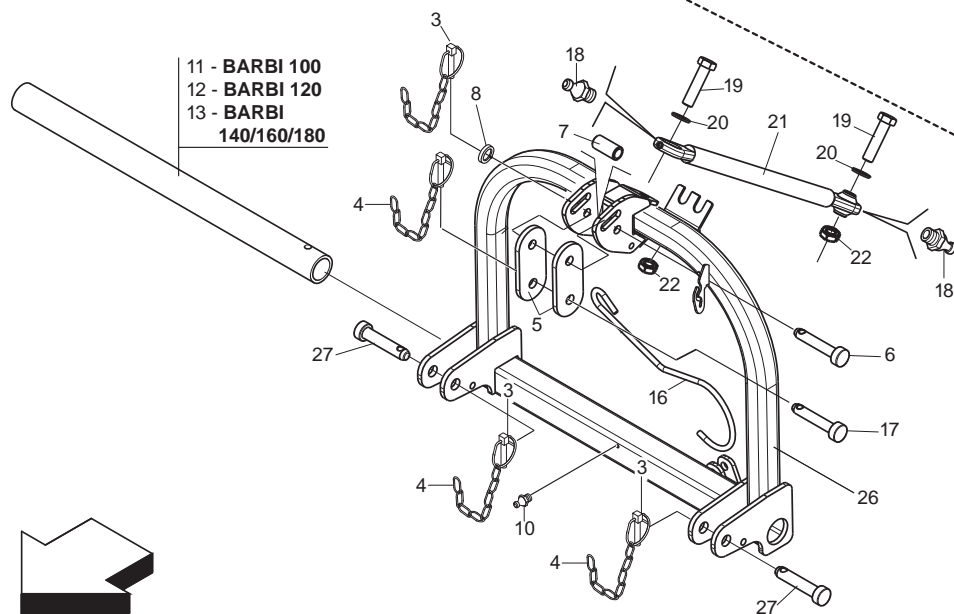
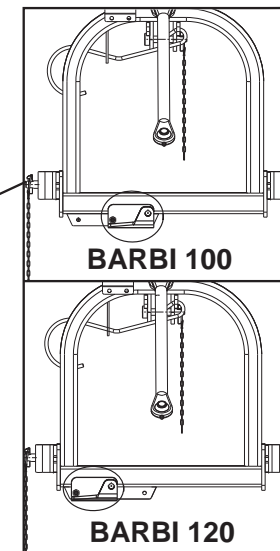
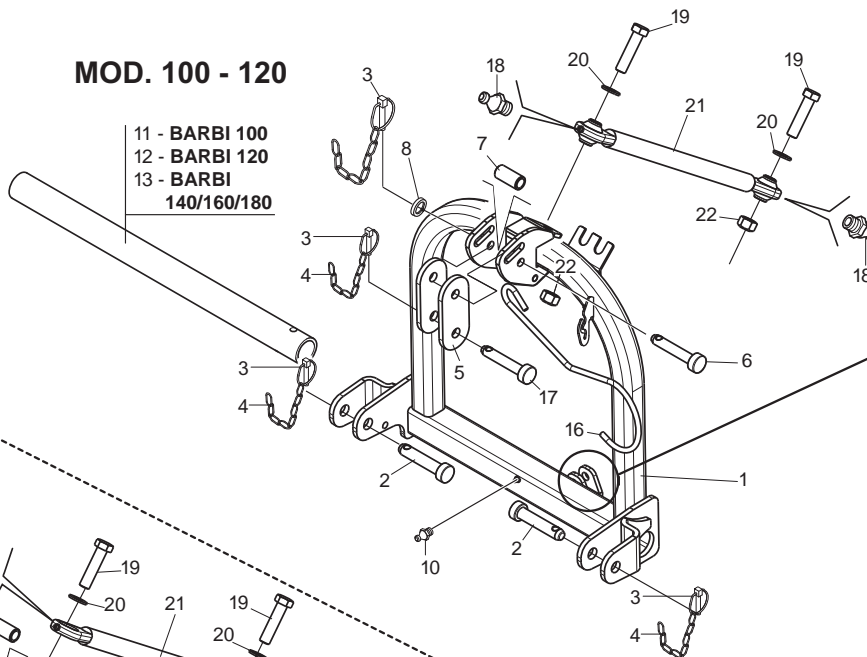

- 11 - BARBI 100
- 12 - BARBI 120
- 13 - BARBI 140/160/180

MOD. 140 - 160 - 180

- 23 - BARBI 100
- 24 - BARBI 120
- 25 - BARBI 140-160-180

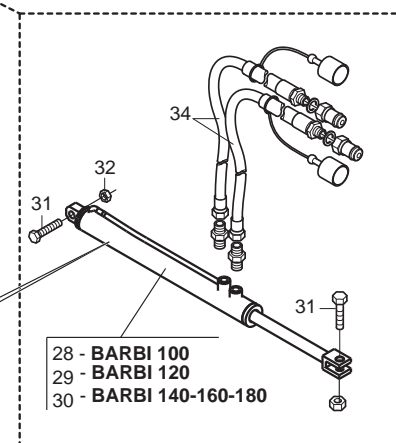

SPOSTAMENTO IDRAULICO
HYDRAULIC OFFSET

- 28 - BARBI 100
- 29 - BARBI 120
- 30 - BARBI 140-160-180

GR. 3° PUNTO / 3RD-POINT

TAV. 020

Pos.	Cod.	Descrizione	Description	Benennung	Description	Description
1	M33400556R	TERZO PUNTO SPOSTABILE CAT.1	OFFSET 3RD POINT CAT.1			
2	F20100049R	PERNO D22 L86 C43 TEST.D35 ZN	BOLT D22 L86 C43 ZN	GOUJON D.22	BOLZEN D.22	PERNO D.22
3	F02200529R	SPINA SCATTO D.11 H58 ZN	SNAP PIN D.11 H58 ZN	FICHE A DETENTE D.11 H58 ZN	EINRASTSTIFT D.11 H58 ZN	CLAVIJA DE MUELLE D.11 H58 ZN
4	M58100930R	CATENELLA L=476	ASSEMBLY CHAIN DMP L=476	CHAINE L=476	KETTE L=476	CADENA L=476
5	M33400568R	BIELLA	CONNECTING ROD	BIELLE	PLEUEL	BIELA
6	F20100033R	PERNO D19 L137 C43 TEST.D35 ZN	BOLT D=19 L=137	GOUJON D=19 L=137	STIFT D=19 L=137	PERNO D=19 L=137
7	M73100911R	BUSSOLA	BUSH	BOUSSOLE	DISTANZBUECHSE	BRUJULA
8	F01410124R	ROS.M20 21X 37X 3 U6592 ZN	WASHER M20 21X 37X 3 U6592 ZN	RONDEL.M20 21X37X3 ZN	MUTTER M20 21X 37X 3 U6592 ZN	ARANDELA M20 21X37X3 U6592 ZN
9	F01010341R	VITE M16X1,5X45 U5740 8.8ZN	SCR. M16X1,5X45 U5740 8.8ZN	VIS M16X1,5 X45 U5740 8.8 ZN	SCHR.M16X1,5 X45 U5740 8.8 ZN	TORN.M16X1,5 X45 U5740 8.8 ZN
10	F01100048R	ING.M 8X1,25 7663A 9SMNPB28 Z	GREASE NIPPLE M8X1,25 U7663A	GRAISSEUR A BILLES M8X1,25	SCHMIERBUECHSE M8X1,25 7663A	ENGRAS. DE ESFERAS M8 X 1,25 A
11	M33410566R	ASTA SCORRIMENTO 100	SLIDING ROD 100	TIGE DE GLISSEMENT 100	GLEITSTANGE 100	BARRA DESLIZAMIENTO 100
12	M33412566R	ASTA SCORRIMENTO 120	SLIDING ROD 120	TIGE DE GLISSEMENT 120	GLEITSTANGE 120	BARRA DESLIZAMIENTO 120
13	M33416566R	ASTA SCORRIMENTO 140-160-180	SLIDING ROD 140-160-180	TIGE DE GLISSEMENT 140-160-180	GLEITSTANGE 140-160-180	BARRA DESLIZAMIENTO140-160-180
14	F02200485R	SPINA SCATTO D.6 SPEC. ZG	SNAP PIN D.6 ZN	GOUPILE D.6	SPLINT D.6	RODETE D.6
15	M38100573R	PERNO DI REGOLAZIONE ZGPD	PIN	GOUJON	BOLZEN	PERNO
16	F20120400R	GANCIO SOSTEGNO CARDANO	SHAFT HOOK SUPPORT	SUPPORT CARDAN	GELENKWELLE - HACKEN	SOPORTE CARDAN
17	F20100035R	PERNO D19 L90 C43 TEST.D35 ZN	BOLT D19 L86 C43 ZN	BOULON D19 L86 C43 ZN	BOLZEN D19 L86 C43	PERNO D19 L86 C43
18	F01100011R	ING.M 6X1 7663-A 9SMNPB28 ZN	GREASE NIPPLE M6X1 7663-A ZN	GRAISS. A BILLE M6X1 7663A ZN	SCHMIERBUECHE M6X1 7663-A ZN	ENGRAS. DE ESFE. M6X1 7663-AZN
19	F01010172R	VITE M20X1,5X80 U5738 8.8ZN	SCR. M20X1,5X80 U5738 8.8ZN	VIS M20X1,5X80	SCHRAUBE M20X1,5X80	TORNILLO M20X1,5X80
20	F01410124R	ROS.M20 21X 37X 3 U6592 ZN	WASHER M20 21X 37X 3 U6592 ZN	RONDEL.M20 21X37X3 ZN	MUTTER M20 21X 37X 3 U6592 ZN	ARANDELA M20 21X37X3 U6592 ZN
21	M71100538R	COMP.TIRANTE 3 PUNTO ZG	FLOATING LINK	TIRANT OSCILLATION	SCHWENKBARE STREBE	TIRANTE OSCILACION
22	F01220093R	DADO M20X1,5 D980 8ZN	NUT M20X1,5 D980 8ZN	ECROU AUTOBL.M20X1,5 ZN	SELB.MUTTER M20X1,5 D980 8ZN	TUERCA AUTOBL.M20X1,5 D980 8ZN
23	F03100155R	SERIE GUARN.X CIL. M33410549	GASKET SET	SERIE JOINTS	DICHTUNGSSATZ	SERIE JUNTAS
24	F03100156R	SERIE GUARN.X CIL. M33412549	GASKET SET	SERIE JOINTS	DICHTUNGSSATZ	SERIE JUNTAS
25	F03100157R	SERIE GUARN.X CIL. M33416549	GASKET SET	SERIE JOINTS	DICHTUNGSSATZ	SERIE JUNTAS
26	M33400544R	TERZO PUNTO SP.BARBI 140 180	3RD POINT SP.BARBI 140 181			
27	F20100049R	PERNO D22 L86 C43 TEST.D35 ZN	BOLT D22 L86 C43 ZN	GOUJON D.22	BOLZEN D.22	PERNO D.22
28	M33410549R	MARTINETTO IDRAUL. BARBI 100	HYDRAULIQUE ADJUSTER	MANIVELLE HYDRAULIQUE	HYDRAUL.SPINDELVERSTELLUNG	GATO HYDRAULICO
29	M33412549R	MARTINETTO IDRAUL. BARBI 120	HYDRAULIQUE ADJUSTER	MANIVELLE HYDRAULIQUE	HYDRAUL.SPINDELVERSTELLUNG	GATO HYDRAULICO
30	M33416549R	MARTINETTO IDRAUL.BARBI140-180	HYDRAULIQUE ADJUSTER	MANIVELLE HYDRAULIQUE	HYDRAUL.SPINDELVERSTELLUNG	GATO HYDRAULICO
31	F01010115R	VITE M16X1,5X55 U5738 8.8ZN	SCR. M16X1,5X55 U5738 8.8ZN	VIS M16X1,5 X55 U5738 8.8ZN	SCHRAU. M16X1,5X55 U5738 8.8ZN	TORN. M16X1,5X55 U5738 8,8ZN
32	F01220070R	DADO M16X1,5 D980 10ZN	NUT M16X1,5 D980 8ZN	ECRO.M16X1,5 D980 8ZN	MUTTER M16X1,5 D980 8ZN	TUER.M16X1,5 D980 8ZN
33	M33400560R	ASTA SPOST.MECCANICO	ROD	BARRE	HOLM	VARILLA
34	F03060186R	KIT TUB.IDR.GUAINA L3000 DIN24	KIT TUB.IDR. STE. L3000 DIN24			
35	M33400565R	ASTA SPOST.MECCANICO ZPG	ROD	BARRE	HOLM	VARILLA

TAV. 030

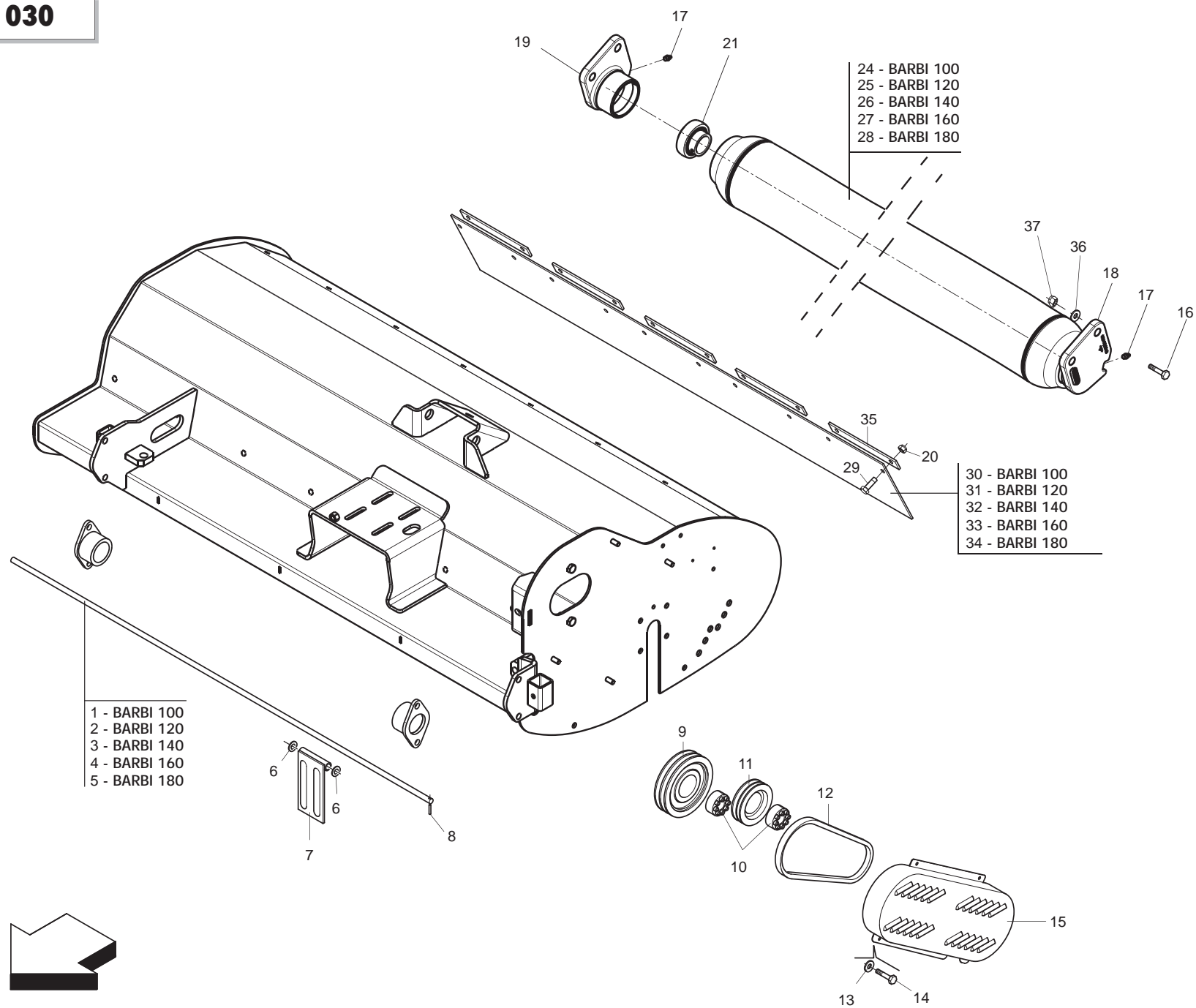

TRASMISSIONE - GRUPPO RULLO / TRANSMISION - ROLLER UNIT

TAV. 030

Pos.	Cod.	Descrizione	Description	Benennung	Description	Description
1	T21095016R	ASTA PER BANDELLE	PIN	GOUJON	BOLZEN	PERNO
2	T21115016R	ASTA PER BANDELLE	PIN	GOUJON	BOLZEN	PERNO
3	T21135016R	ASTA PER BANDELLE	PIN	GOUJON	BOLZEN	PERNO
4	T21155016R	ASTA PER BANDELLE	PIN	GOUJON	BOLZEN	PERNO
5	T21185016R	ASTA PER BANDELLE BCA180-BL170	PIN	GOUJON	BOLZEN	PERNO
6	F01410100R	ROS.M16 17X 30X 3 U6592 ZN	WASHER M16 17X30X3 U6592 ZN	RONDELLE M16 17X30X3 ZN	SCHRAUBE M16 17X 30X3 U6592 ZN	ARANDELA M16 17X30X 3 U6592 ZN
7	M24400518R	BANDELLA PROTEZ. 93X170 ZG	PROTECTION BAR	BANDE PROTECTION	SCHUTZWORNE	ALETA PROTECCION
8	F02100114R	SPINA E.P. 6X 30 U6873 C70 BR	ELASTIC PIN 6X30	GOUJON ELASTIQUE 6X30	SPANNHUELSE 6X30	ESPINA ELASTICA 6X30
9	T16003002R	PULEGGIA SPB MOTRICE D=225 3V	DRIVING PULLEY	POULIE TIRANTE	ZIEHEN RIEMEN	ROLDANA DE TIRAR
10	F06060037R	CALETTATORE AUTOCENTR.35X80	SELF CENTR.CLAMPEL.35X80	EMBOITAGE AUOBL. 35X80	SELBSTPERR.VERKEILEN 35X80	ENSAMBLADURA AUTOBL. 35X80
11	T22003001R	PULEGGIA ROTORE DP=160	DRIVING PULLEY	POULIE TIRANTE	ZIEHEN RIEMEN	ROLDANA DE TIRAR
12	F06010039R	CINGHIA SPBX L=1320	BELT SPBX L=1320	COURROIE L=1320	SCHAUBE SPBX L=1320	CORREA SPBX L=1320
13	F01410064R	ROS.M10 10,5X 20X 2 U6592 ZN	WASHER M10 10,5X20X2 U6592 ZN	RONDEL. M10 10,5X20X2 U6592 ZN	SCHEIBE M10 10,5X20X2 U6592 ZN	ARANDEL.M10 10,5X20X2 U6592 ZN
14	F01010244R	VITE M10X1,25X25 U5740 8.8ZN	SCR. M10X1,25X25 U5740 8.8ZN	VIS M 10X1,25X25	SCHRAUBE M 10X1,25X25	TORNILLO M 10X1,25X25
15	T16003150R	COMP.CARTER	COMPLETE CARTER			
16	F01010318R	VITE M14X1,5X40 U5740 8.8ZN	SCR. M14X1,5X40 U5740 8.8ZN	VIS M 14X1,5X40	SCHRAUBE M 14X1,5X40	TORNILLO M 14X1,5X40
17	F01100048R	ING.M 8X1,25 7663A 9SMNPB28 Z	GREASE NIPPLE M8X1,25 U7663A	GRAISSEUR A BILLES M8X1,25	SCHMIERBUCHSE M8X1,25 7663A	ENGRAS. DE ESFERAS M8 X 1,25 A
18	EGL01234R	KIT SUPPORTO SX CUSCINETTO	KIT SUPPORT LEFT BEARING			
19	EGL01235R	KIT SUPPORTO DX CUSCINETTO	KIT SUPPORT RIGHT BEARING			
20	F01220022R	DADO M8X1,25 D980 8ZN	NUT M8X1,25 D980 8ZN	ECROU M8X 1,25 D980 8 ZN	MUTTER M8X 1,25 D980 8 ZN	TUERCA M8X 1,25 D980 8 ZN
21	F04010361R	CUSC. YAR 207-2FW VA201	BEARING YAR 207			
24	M33410611R	RULLO POSTERIORE D=139,7	REAR ROLLER D=139,7			
25	M33412611R	RULLO POSTERIORE D=139,7	REAR ROLLER D=139,7			
26	M33414611R	RULLO POSTERIORE D=139,7	REAR ROLLER D=139,7			
27	M33416611R	RULLO POSTERIORE D=139,7	REAR ROLLER D=139,7			
28	M33418611R	RULLO POSTERIORE D=139,7	REAR ROLLER D=139,7			
29	F01020436R	VITE M8X1,25X20 U5739 8.8ZN	SCR. M8X1,25X20 U5739 8.8ZN	VIS M8X1,25X 20 U5739 8.8 ZN	SCHRAUBE M8X1,25X20U5739 8.8ZN	TORN. M8X1,25X20 U5739 8.8 ZN
30	M33410544R	PROTEZ.POSTER. BARBI 100 07	REAR GUARD BARBI 100 07			
31	M33412544R	PROTEZ.POSTER.120	REAR PROTECTION 120	PROTECTION ARRIERE 120	HINTERER SCHUTZ 120	PROTECCION TRASERA 120
32	M33414544R	PROTEZ.POSTER.140	REAR PROTECTION 140	PROTECTION ARRIERE 140	HINTERER SCHUTZ 140	PROTECCION TRASERA 140
33	M33416544R	PROTEZ.POSTER.160	REAR PROTECTION 160	PROTECTION ARRIERE 160	HINTERER SCHUTZ 160	PROTECCION TRASERA 160
34	M33418544R	PROTEZ.POSTER.180	REAR PROTECTION 180	PROTECTION ARRIERE 180	HINTERER SCHUTZ 180	PROTECCION TRASERA 180
35	M07400953R	PIATTO PER ATTACCO GOMMA	PLATE	PLAT	PLATTE	PLATO
36	F01410088R	ROS.M14 15X 28X2,5 U6592 ZN	WAS.M14 15X 28X2,5 U6592 ZB	RON.M14 15X 28X2,5 U6592 ZB	SCH.M14 15X 28X2,5 U6592 ZB	ARA.M14 15X 28X2,5 U6592 ZB
37	F01220059R	DADO M14X1,5 D980 8ZN	NUT M14X1,5 D980 8ZN	ECROU M14X 1,5 D980 8 ZN	MUTTER M14X 1,5 D980 8 ZN	TUERCA M14X 1,5 D980 8 ZN

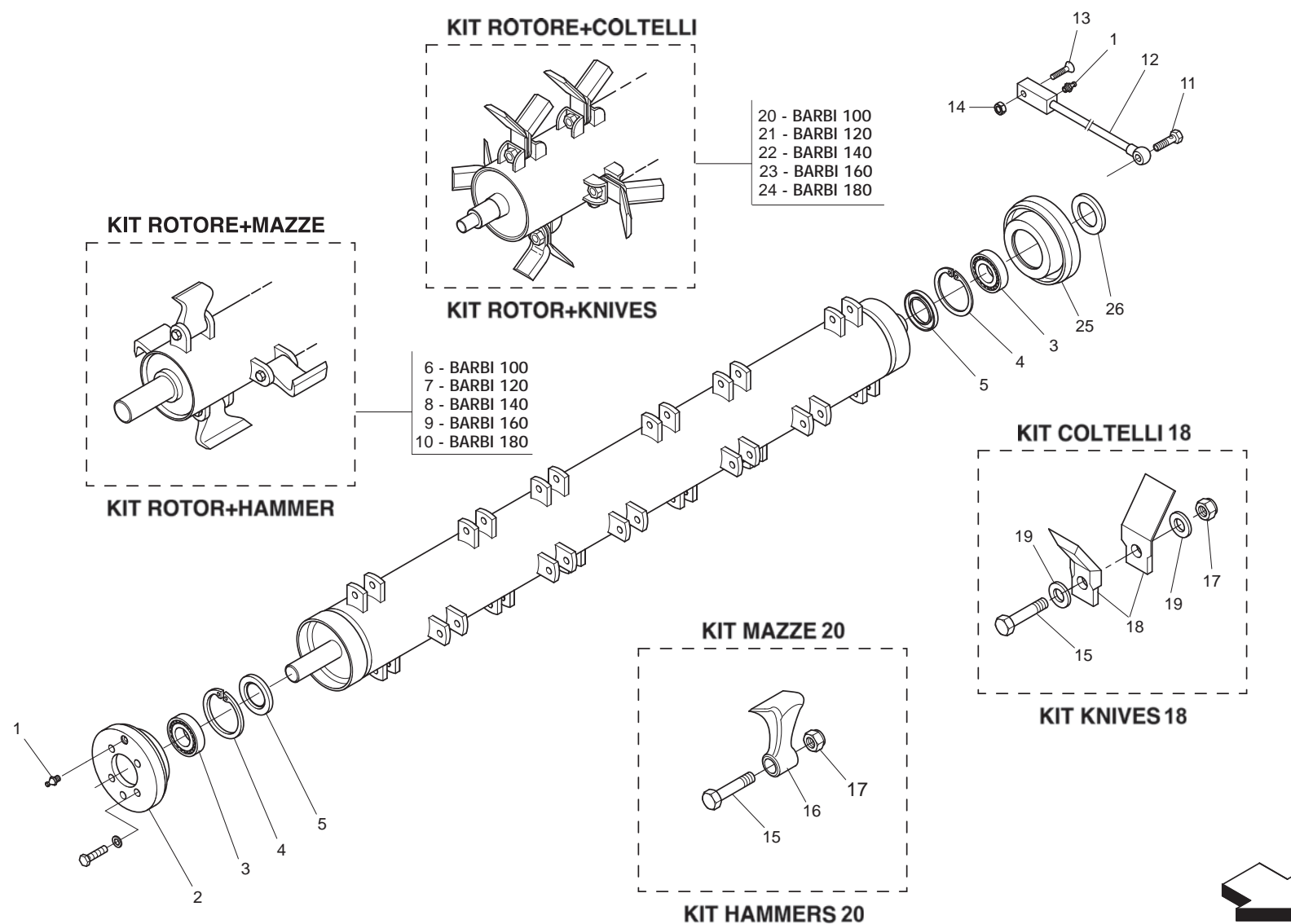

- 20 - BARBI 100
- 21 - BARBI 120
- 22 - BARBI 140
- 23 - BARBI 160
- 24 - BARBI 180

- 6 - BARBI 100
- 7 - BARBI 120
- 8 - BARBI 140
- 9 - BARBI 160
- 10 - BARBI 180

ROTORE / ROTOR

TAV. 040

Pos.	Cod.	Descrizione	Description	Benennung	Description	Description
1	F01100011R	ING.M 6X1 7663-A 9SMNPB28 ZN	GREASE NIPPLE M6X1 7663-A ZN	GRAISS. A BILLE M6X1 7663A ZN	SCHMIERBUECHE M6X1 7663-A ZN	ENGRAS. DE ESFE. M6X1 7663-AZN
2	M22400406R	SUPPORTO ROTORE DX	RIGHT ROTOR SUPPORT	SUPPORT ROTOR DROITE	ROTORHALTER RECHTE	SOPORTE ROTOR DERECHO
3	F04010032R	CUSC.D35 D72 B23 22207	BEARING D35 D72 B23 22207			
4	F02050403R	ANELLO E. DI 72X 2,5 U7437 C7	SEEGER RING E.72X2.5 U7437 C70	SEEGER E. 72X 2,5 U7437 C70	SEEGERING E. 72X 2,5 U7437 C70	ANILLO E. 72X 2,5 U7437 C70
5	F03010136R	ANELLO T.AS.45X 72X 8 D3760NB	OIL SEAL 45X72X8 D3760NBR	PARE-HUILE 45X72X8	OELABDICHTUNG 45X72X8	JUNTA DE ACEITE 45X72X8
6	MSP000125R	ROTORE BARBI 100 M20 NO SUPP.	ROTOR BARBI 100 HAMMER 20			
7	MSP000127R	ROTORE 120 M20 NO SUPP.	ROTOR 120 HAMMER 20	ROTOR 120 MARTEAUX 20	LAEUFER 120 SCHLEGEL 20	ROTOR 120 MARTILLO 20
8	MSP000129R	ROTORE 140 M20 NO SUPP.	ROTOR 140 HAMMER 20	ROTOR 140 MARTEAUX 20	LAEUFER 140 SCHLEGEL 20	ROTOR 140 MARTILLO 20
9	MSP000131R	ROTORE 160 M20 NO SUPP.	ROTOR 160 HAMMER 20	ROTOR 160 MARTEAUX 20	LAEUFER 160 SCHLEGEL 20	ROTOR 160 MARTILLO 20
10	MSP000133R	ROTORE BARBI 180 M20 NO SUPP.	ROTOR BARBI 180 HAMMER 20			
11	T24004003R	VITE FORATA PER INGRASSAGGIO	BOLT	VIS	SCHRAUBE	TORNILLO
12	T24004000R	ASSIEME INGRASSATORE	GREASE NIPPLE	GRAISSEUR	SCHMIERNIPPEL	ENGRASADOR
13	F01030058R	VITE M8X1,25X30 U5933 10.9ZD	SCR. M8X1,25X30 U5933 10.9ZD	VIS M8 X1,25 X30 U5933 10,9 ZD	SCHRAUBE M8X1,25X30 U5933 10,9	TORNILLO M8X1,25X30 U5933 10,9
14	T24004000R	ASSIEME INGRASSATORE	GREASE NIPPLE	GRAISSEUR	SCHMIERNIPPEL	ENGRASADOR
15	F01010121R	VITE M16X1,5X90 U5738 8.8ZN	SCR. M16X1,5X90 U5738 8.8ZN	VIS M 16X1,5X90 ZN	SCHRAUBE M 16X1,5X90	TORNILLO M 16X1,5X90
16	M07400950R	MAZZA 20 STAMPATA	HAMMER 20	MARTEAU 20 BARBI-GIRAFETTA	SCHLEGEL	MARTILLO
17	F01230084R	DADO M16X1,5 D982 6ZN	NUT M16X1,5 D982 6ZN	ECROU AUTOBL.M16X1,5 ZN	SELBSTSPERR.MUTTER M16X1,5	DADO AUTOBL. M16X1,5
18	M07400954R	COLTELLO 18	KNIFE*18	COUTEAU 18 GALVANISE P		
19	T21004046R	DISTANZIALE COLTELLO ZPG	SPACER KNIFE	DIUTEAU TIPE ZN		
20	MSP000126R	ROTORE BARBI 100 C18 NO SUPP.	ROTOR BARBI 100 BLADE 18			
21	MSP000128R	ROTORE 120 COLT. 18	ROTOR 120 BLADE 18	ROTOR 120 COUTEAUX 18	LAEUFER 120 MESSER 18	ROTOR 120 CUCHILLO 18
22	MSP000130R	ROTORE 140 COLT. 18	ROTOR 140 BLADE 18	ROTOR 140 COUTEAUX 18	LAEUFER 140 MESSER 18	ROTOR 140 CUCHILLO 18
23	MSP000132R	ROTORE 160 COLT. 18	ROTOR 160 BLADE 18	ROTOR 160 COUTEAUX 18	LAEUFER 160 MESSER 18	ROTOR 160 CUCHILLO 18
24	MSP000134R	ROTORE BARBI 180 C18 NO SUPP.	ROTOR BARBI 180 BLADE 18			
25	M22400405R	SUPPORTO ROTORE SX	LEFT ROTOR SUPPORT	SUPPORT ROTOR GAUCHE	ROTORHALTER LINKS	SOPORTE ROTOR IZQUIERDO
26	F03010086R	ANELLO T.A 35X 62X 7 D3760NBR	OIL SEAL 35X62X7	PARE-HUILE 35X62X7	OELABDICHTUNG 35X62X7	PARA-ACEITE 35X62X7

TAV. 050

RUOTA LIBERA ALL'INTERNO DELLA SCATOLA

FREE WHEEL INSIDE THE GEARBOX

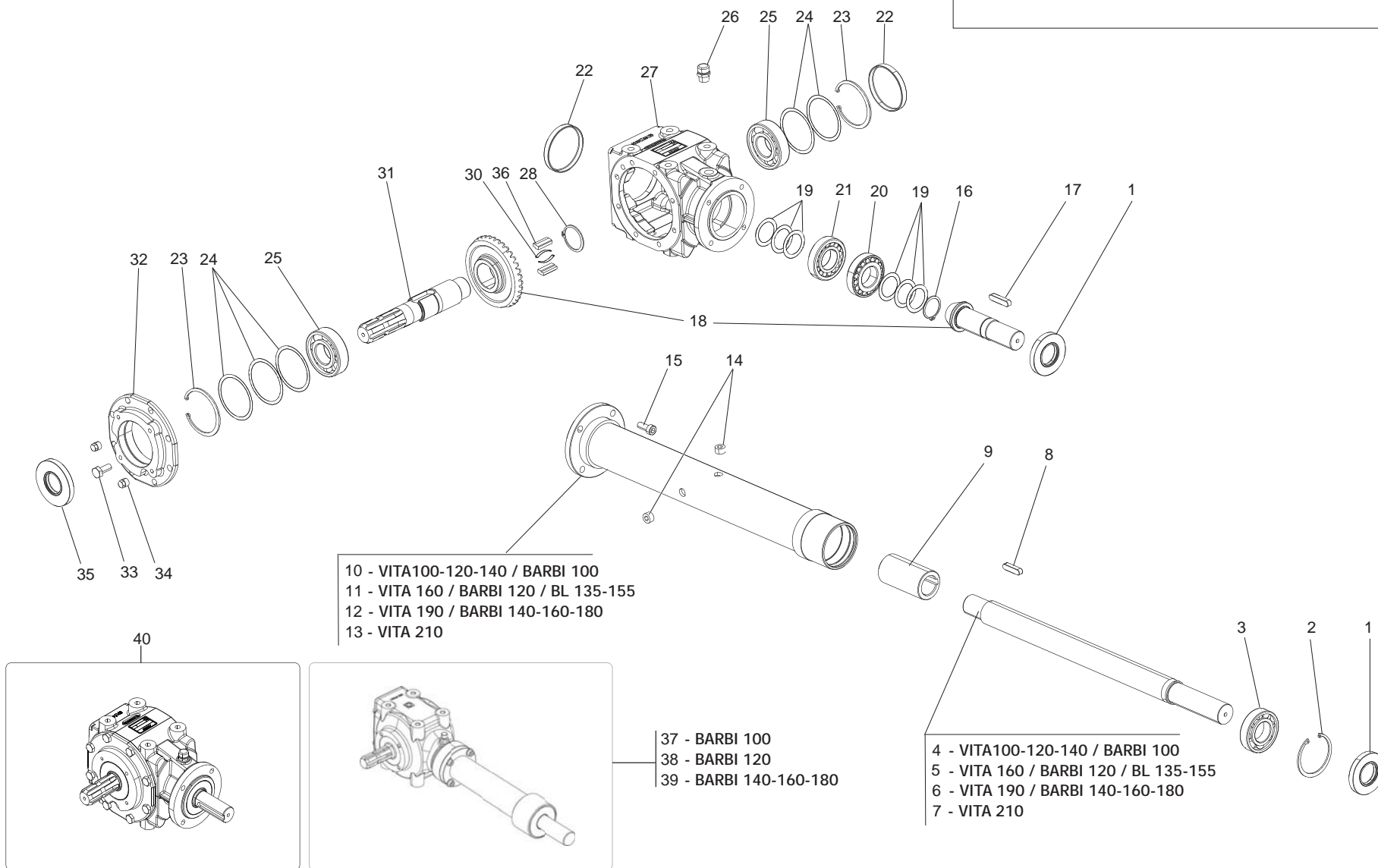

ESPLOSO MOLTIPLICATORE / GEARBOX EXPLODED

TAV. 050

Pos.	Cod.	Descrizione	Description	Benennung	Description	Description
1	F03010088R	ANELLO T.AS.35X 72X10 D3760NB	OIL SEAL 35X72X10	PARA-HUILLE 35X72X10	OELABDICHTUNG 35X72X10	PARA-ACEITE 35X72X10
2	F02050403R	ANELLO E. DI 72X 2,5 U7437 C7	SEEGER RING E.72X2,5 U7437 C70	SEEGER E. 72X 2,5 U7437 C70	SEEGERING E. 72X 2,5 U7437 C70	ANILLO E. 72X 2,5 U7437 C70
3	F04010175R	CUSC.D35 D72 B17 6207	BEARING D35 D72 B17 6207	ROULEMENT 6207	LAGER 6207	COJINETE 6207
4	M22409202R	ALBERO DI RINVIO D=40 L=318,5	SHAFT D=40 L=318,5	ARBRE D=40 L=318,5	ZENTRALWELLE D=40 L=318,5	ARBOL D=40 L=318,5
5	M22413202R	ALBERO DI RINVIO D.40 L.418,5	SHAFT D=40 L=418,5			
6	M22414202R	ALBERO DI RINVIO D.40 L.503,5	SHAFT D=40 L=503,5			
7	M22416202R	ALBERO DI RINVIO D.40 L.603,5	SHAFT D=40 L=603,5			
8	F02150101R	LINGUETTA 10X 8X 40 U6604A	PARALLEL KEY 10X 8X 40 U6604A	LANGUETTE 10X8X40	FEDER 10X8X40 UNI 6604	LLAVE 10X8X40
9	M22400203R	GIUNTO	JOINT			
10	M22409201R	DISTANZIALE LATO TRASMISSIONE	LEFT SPACER	ENTRETOISE GAUCHE	LINKES DISTANZROHR	DISTANCIADOR IZQ.
11	M22413201R	DISTANZIALE L. TRASM. L.400	TRANSM. SIDE SPACER L.400			
12	M22414201R	DISTANZIALE L. TRASM. L.485	TRANSM. SIDE SPACER L.485			
13	M22416201R	DISTANZIALE L. TRASM. L.585	TRANSM. SIDE SPACER L.585			
14	M29100112R	TAPPO SCARICO OLIO	OIL OUTLET PLUG	BOUCHON DE VIDANGE HUILE	OELABLASSPFROPFEN	TAPON DESCARGADO ACEITE
15	F01040119R	VITE M10X1,5X25 U5931 8.8BR	SCR. M10X1,5X25 U5931 8.8BR	VIS M10X1,5X25	SCHRAUBE M10X1,5X25	TORNILLO M10X1,5X25
16	M07400004R	SEEGER 35X33X2,5	SEEGER RING 35X33X2,5	BAGUE SEEGER D 35X33X2,5	SEEGERRING D 35X33X2,5	ANILLO D 35X33X2,5
17	F02150102R	LINGUETTA 10X 8X 45 U6604A	PARALLEL KEY 10X 8X 45 U6604A	CLAVETTE 10X8X45	KEIL 10X8X45	LLAVE 10X8X45
18	M22400110	COPPIA CONICA 12 36	BEVEL GEAR PAIR 12 36			
19	M07400002R	KIT SPESSORI 0,3 4 5	REINFORCEMENTS	RENFORTS	VERSTAERKERUNGEN	RENFUERZOS
20	F04010175R	CUSC.D35 D72 B17 6207	BEARING D35 D72 B17 6207	ROULEMENT 6207	LAGER 6207	COJINETE 6207
21	F04050014R	CUSC.D35 D72 T18,25 30207	BEARING D35 D72 T18,25 30207	ROULEMENT 30207	LAGER 30207	COJINETE 30207
22	F03011026R	TAPPO CHIUSURA D=80 X 10 GA	COVER D. 80X10	BOUCHON 80X10	DECKEL 80X10	CORCHO 80X10
23	F02050425R	ANELLO E. DI 80X 2,5 U7437 C70	SEEGER RING D.80	BAGUE SEEGER D.80	SEEGERRING D.80	ANILLO SEEGER D.80
24	M07400006R	3 4 5.00 KIT SPESSORI	REINFORCEMENTS	RENFORTS	VERSTAERKERUNGEN	RENFUERZOS
25	F04010216R	CUSC.D35 D80 B21 6307	BEARING D35 D80 B21 6307	ROULEMENT 6307	LAGER 6307	COJINETE 6207
26	F03150718R	TAPPO 3 8 GAS CON SFIATO	GAS BREATHER PLUG 3 8	BOUCHON D HUILE SOUPIRAL	OELENTLUEFTERSTOPFEN	TAPON ACEITE
27	M22400101R	CORPO RIDUTTORE	GEARBOX	BOITE DE VITESSE	WECHSELGETRIEBEGEHAUSE	CAJA CAMBIO
28	M03400007R	ANELLO EL.SIC. X ALB 42 UNI743	SEEG.42X39,5X1,75.			
30	M03400009R	MOLLA	SPRING	RESSORT	FEDER	MUELLE
31	M07400001R	0.311.3201.00 1 3 8 Z6 ALBERO	SHAFT	ARBRE	ZENTRALWELLE	ARBOL
32	M22400102R	COPERCHIO	GEARBOX COVER	COUVERCLE BOITE A VITESSES	GETRIEBEDECKEL	TAPA CAJA CAMBIO
33	F01010244R	VITE M10X1,25X25 U5740 8.8ZN	SCR. M10X1,25X25 U5740 8.8ZN	VIS M 10X1,25X25	SCHRAUBE M 10X1,25X25	TORNILLO M 10X1,25X25
34	F03150652R	TAPPO CONICO CON ES.INC. 1 4	HEXAGONAL PLUG 1 4	BOUCHON CONIQUE 1 4	KONISCHER VERSCHLUSS 1 4	CIERRE CONICO 1 4
35	F03010265R	ANELLO T.AS 35X 80X10 D3760NBR	RING T.AS 35X80X10 D3760 NBR	BAGUE T.AS 35X 80X10 D3760 NBR	SCHUTZRING 35X80X10 D3760 NBR	INEL T.AS 35X80X10 D3760 NBR
36	M07400005R	LINGUETTA	PARALLEL KEY	CLAVETTE	FEDER	LLAVE
37	M22409205R	GRUPPO MOLTIPLICATORE 540 RPM	GR.MOLTIPL.540 RPM			
38	M22413205R	GRUPPO MOLTIPLICATORE 540 RPM	GR.MOLTIPL.540 RPM			
39	M22414205R	GRUPPO MOLTIPLICATORE 540 RPM	GEARBOX 540 RPM			
40	M41400203R	SCATOLA MOLT. MASCHIO 540 RPM	GEARBOX MASCHIO 540 RPM			

OPTIONAL

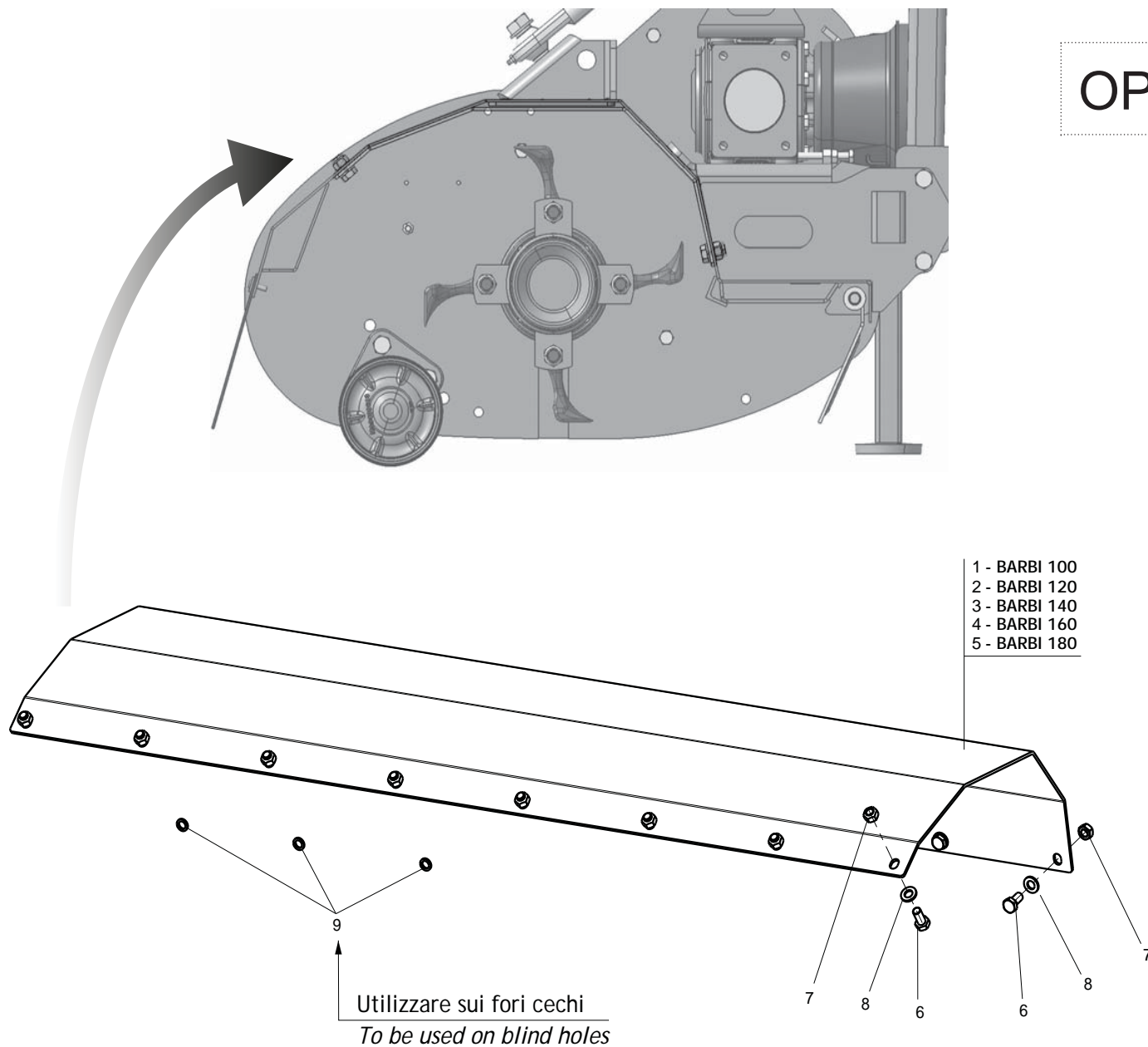

LAMIERA ANTIUSURA (OPTIONAL) / OPTIONAL DOUBLE SKIN FRAME

TAV. 060

Pos.	Cod.	Descrizione	Description	Benennung	Description	Descripcion
1	M33410598R	LAMIERA ANTIUSURA	DOUBLE SKIN FRAME			
2	M33412598R	LAMIERA ANTIUSURA	DOUBLE SKIN FRAME			
3	M33414598R	LAMIERA ANTIUSURA	DOUBLE SKIN FRAME			
4	M33416598R	LAMIERA ANTIUSURA	DOUBLE SKIN FRAME			
5	M33418598R	LAMIERA ANTIUSURA	DOUBLE SKIN FRAME			
6	M71100532R	VITE M12X1,25X 25 SPEC.8.8 ZN	BOLT M12X1,25X25	VIS M12X1,25X25	SCHRAUBE M12X1,25X25	TORNILLO M12X1,25X25
7	F01220047R	DADO M12X1,25 D980 8ZN	NUT M12X1,25 D980 8ZN	ECROU M12X1,25 D980 8 ZN	MUTTER M12X1,25 D980 8 ZN	TUERCA M12X1,25 D980 8 ZN
8	F01410076R	ROS.M12 13X 24X2,5 U6592 ZN	WASHER 12 13X 24X2,5 U6592 ZN	RONDEL. M12 13X24X2,5 U6592 ZN	SCHEIBE M12 13X24X2,5 U6592 ZN	ARANDELA M12 13 X24X2,5 ZN
9	F01480055R	ROS.G 12,2X 18X2,5 D7980 ZN	WASHER. 12.2X18X2,5 D7980ZN	ROND.ELAST. 12,2X18X2,5D7980ZN	FEDERRINGE 12,2X18 2,5 D7980ZN	ARAND. EL. 12,2X18X2,5 D7980ZN

TAV. 070

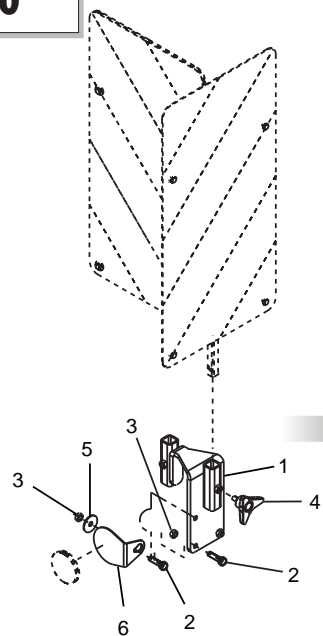

VALIDO PER I KIT:
VALID FOR KITS:
G99600006
G99600017

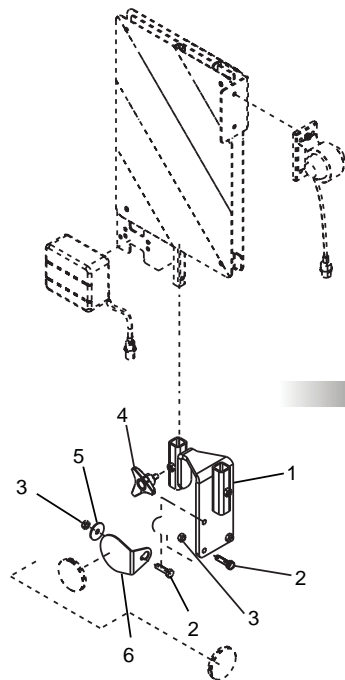
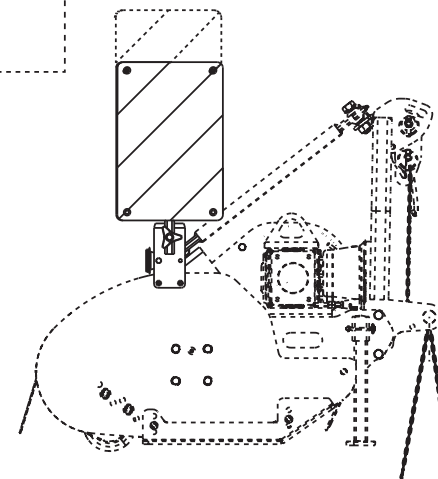
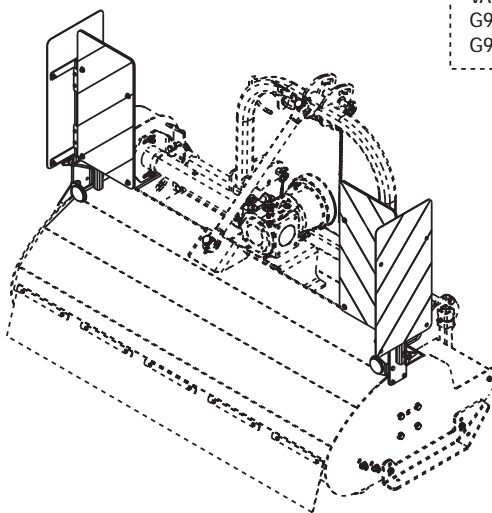

VALIDO PER I KIT:
VALID FOR KITS:
G99600018

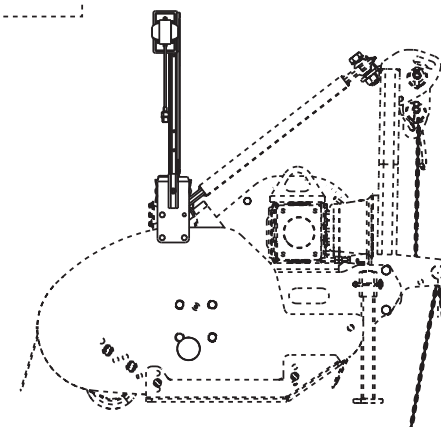
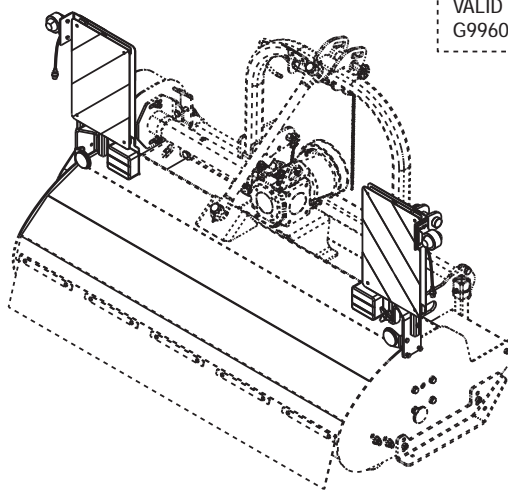

SUPPORTI TABELLE STRADALI / ROAD KIT SUPPORTS

TAV. 070

Pos.	Cod.	Descrizione	Description	Benennung	Description	Descripcion
1	M04700555R	STAFFA SUPPORTO	SUPPORT BRACKET			
2	F01020445R	VITE M8X1,25X30 U5739 8.8ZN	SCR. M8X1,25X30 U5739 8.8ZN	VIS M 8X1,25X30 U5739 8.8 ZN	SCHRAU, M8X1,25X30 U5739 8.8ZN	TORN. M8X1,25X30 U5739 8.8 ZN
3	F01220022R	DADO M8X1,25 D980 8ZN	NUT M8X1,25 D980 8ZN	ECROU M8X 1,25 D980 8 ZN	MUTTER M8X 1,25 D980 8 ZN	TUERCA M8X 1,25 D980 8 ZN
4	F06220018R	VOLANTINO 3LOBI D.65-M8X15	3-LOBE HANDWHEEL D.65-M8X15			
5	F01420049R	ROS.M8 8,4X 32X 2 U6593 ZN	WASHER M8 8,4X32X2 U6593 ZN	RONDELLA M8 8,4X32X2 U6593 ZN	SCHEIBE M8 8,4X32X2 U6593 ZN	ARANDELA M8 8,4X32X2 U6593 ZN
6	M28400701R	SUPPORTO CATADIOTTRO	SUPPORT REFLECTOR			

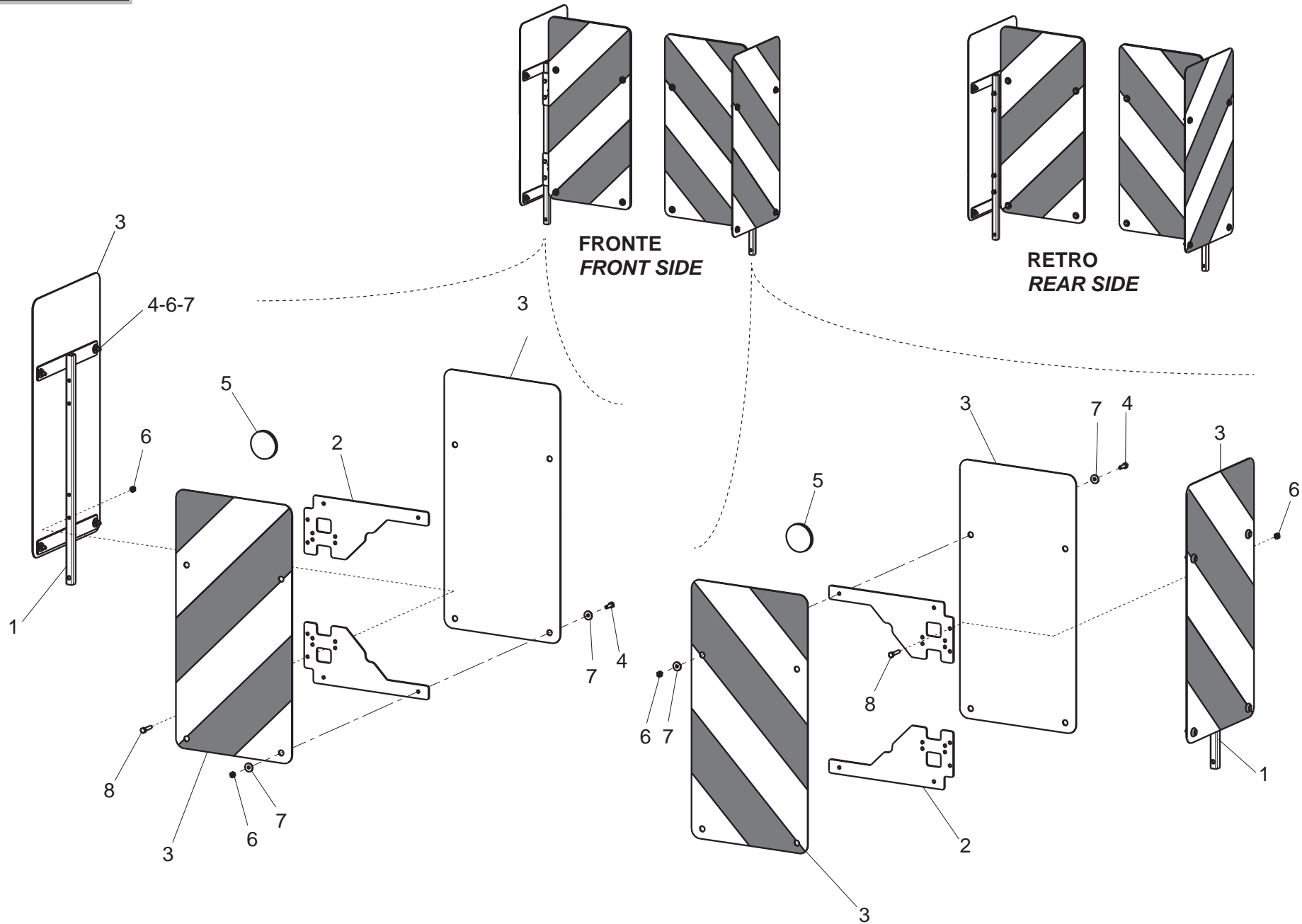

KIT TABELLE STRADALI G99600006 / ROAD TRANSPORT KIT G99600006

TAV. 080

Pos.	Cod.	Descrizione	Description	Benennung	Description	Description
1	G16612070R	TELAIO SUPP.TABELLE STRAD.	FRAME SUPPORT TABLE			
2	M04700558R	SUPPORTO TABELLA INGOMBRO	LIGHT-CHART SUPPORT			
3	F05010816R	TABELLE 2 CAR.SPORGENTI IT	WARNING BOARDS 2 IT			
4	F01020404R	VITE M6X1X20 U5739 8.8ZN	SCREW M6X1X20 U5739 8.8ZN	VIS M6X1X20 U5739 8.8ZN	SCHRAUBE M6X1X20 U5739 8.8ZN	TORNILLO M6X1X20 U5739 8.8ZN
5	F05010820R	CATARIFR.TONDO D60 ROSSO	ROUND REFLECTOR D.60 RED			
6	F01220011R	DADO M6X1 D980 8ZN	NUT M6X1 D980 8ZN	ECROU M6X1 D980 8 ZN	MUTTER M6X1 D980 8 ZN	TUERCA M6X1 D980 8 ZN
7	F01420036R	ROS.M6 6,4X 18X1,5 U6593 ZN	WASHER M6 6,4X 18X1,5 U6593 ZN	RONDELLE M6 6,4X18X1,5 U6593ZN	SCHEIBEN M6 6,4X18X1,5U6593 ZN	ARANDELA M6 6,4X18X1,5U6593ZN
8	F01020408R	VITE M6X1X30 U5739 8.8ZN	SCR. M6X1X30 U5739 8.8ZN	VIS M 6X1X30	SCHRAUBE M 6X1X30	TORNILLO M 6X1X30

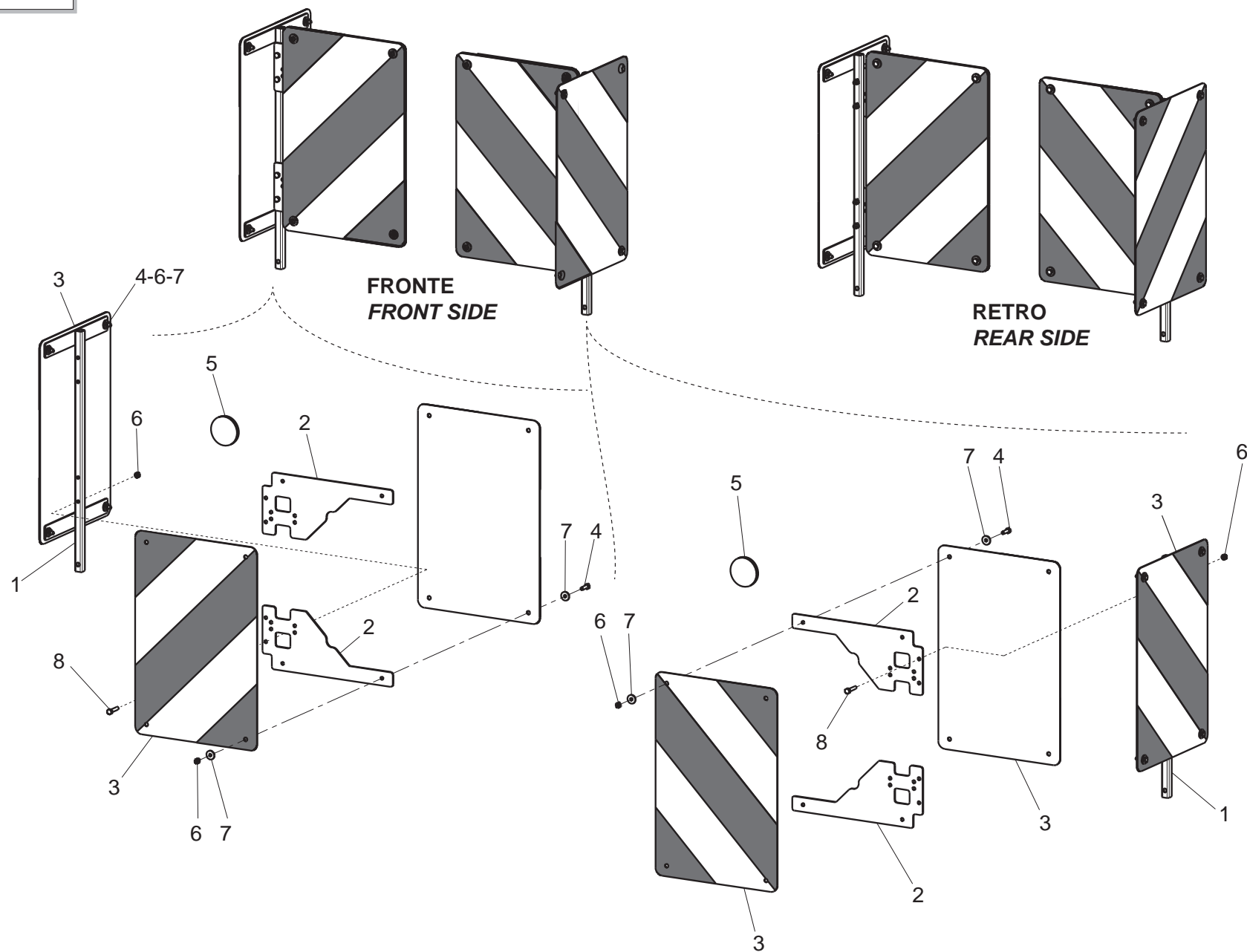

KIT TABELLE STRADALI G99600017 / ROAD TRANSPORT KIT G99600017

TAV. 090

Pos.	Cod.	Descrizione	Description	Benennung	Description	Description
1	G16612070R	TELAIO SUPP.TABELLE STRAD.	FRAME SUPPORT TABLE			
2	M04700558R	SUPPORTO TABELLA INGOMBRO	LIGHT-CHART SUPPORT			
3	F05010817R	TABELLE 2 CAR.SPORGENTI FR-D	WARNING BOARDS 2 FR-DE	TABLEAUX 2 AVERTISSEM. FR-DE	BRETT 2 WARNUNG FR-DE	TABLAS 2 CAR.ADVERT. FR-DE
4	F01020404R	VITE M6X1X20 U5739 8.8ZN	SCREW M6X1X20 U5739 8.8ZN	VIS M6X1X20 U5739 8.8ZN	SCHRAUBE M6X1X20 U5739 8.8ZN	TORNILLO M6X1X20 U5739 8.8ZN
5	F05010820R	CATARIFR.TONDO D60 ROSSO	ROUND REFLECTOR D.60 RED			
6	F01220011R	DADO M6X1 D980 8ZN	NUT M6X1 D980 8ZN	ECROU M6X1 D980 8 ZN	MUTTER M6X1 D980 8 ZN	TUERCA M6X1 D980 8 ZN
7	F01420036R	ROS.M6 6,4X 18X1,5 U6593 ZN	WASHER M6 6,4X 18X1,5 U6593 ZN	RONDELLE M6 6,4X18X1,5 U6593ZN	SCHEIBEN M6 6,4X18X1,5U6593 ZN	ARANDELA M6 6,4X18X1,5U6593ZN
8	F01020408R	VITE M6X1X30 U5739 8.8ZN	SCR. M6X1X30 U5739 8.8ZN	VIS M 6X1X30	SCHRAUBE M 6X1X30	TORNILLO M 6X1X30

TAV. 100

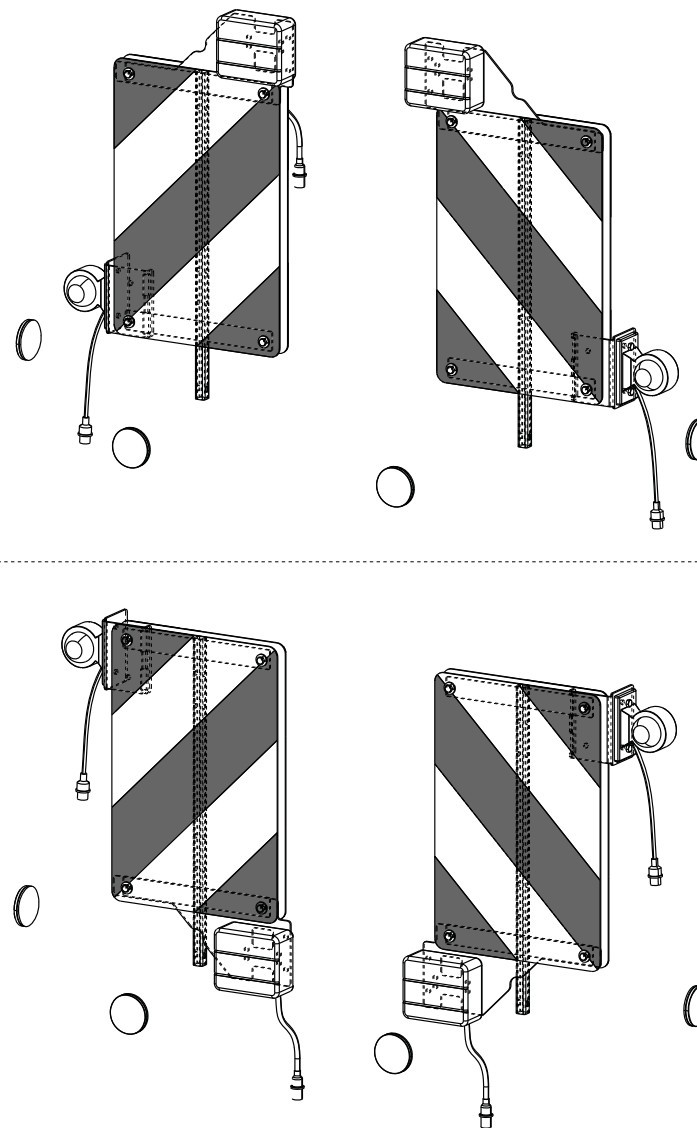
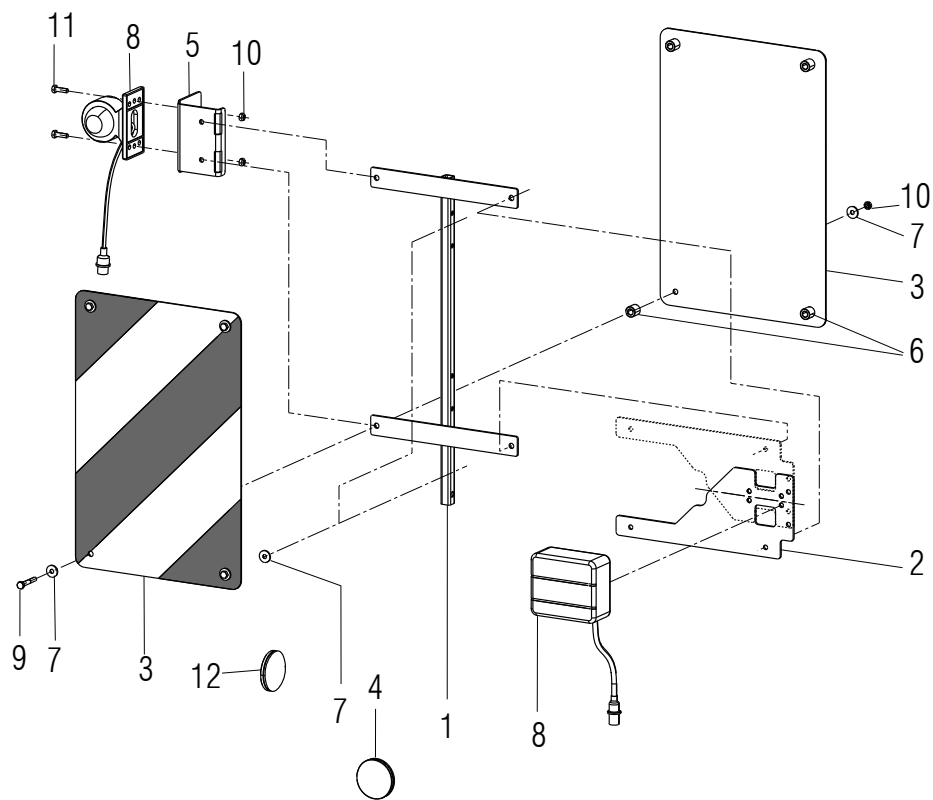

KIT TABELLE STRADALI G99600018 / ROAD TRANSPORT KIT G99600018

TAV. 100

Pos.	Cod.	Descrizione	Description	Benennung	Description	Description
1	G16612070R	TELAIO SUPPTABELLE STRAD.	FRAME SUPPORT TABLE			
2	M04700558R	SUPPORTO TABELLA INGOMBRO	LIGHT-CHART SUPPORT			
3	F05010817R	TABELLE 2 CAR.SPORGENTI FR-D	WARNING BOARDS 2 FR-DE	TABLEAUX 2 AVERTISSEM. FR-DE	BRETT 2 WARNUNG FR-DE	TABLAS 2 CAR.ADVERT. FR-DE
4	F05010820R	CATARIFR.TONDO D60 ROSSO	ROUND REFLECTOR D.60 RED			
5	M04700563R	SUPPORTO LUCE D INGOMBRO	SUPPORT LIGHT OVERALL			
6	G18803050R	BOCCOLA 8,5X16X16 PL	BUSHING 8,5X16X16 PL			
7	F01420036R	ROS.M6 6,4X 18X1,5 U6593 ZN	WASHER M6 6,4X 18X1,5 U6593 ZN	RONDELLE M6 6,4X18X1,5 U6593ZN	SCHEIBEN M6 6,4X18X1,5U6593 ZN	ARANDELA M6 6,4X18X1,5U6593ZN
8	F05010833R	KIT LUCI POST.STRAD.ECCEZ.	KIT REAR ROAD LIGHTS M.EXCEP.			
9	F01020040R	VITE M6X1X40 U5737 8.8ZN	SCR. M6X1X40 U5737 8.8ZN	VIS M6X1X40 U5737 8.8ZN	SCHRAU. M6X1X40 U5737 8.8ZN	TORNI. M6X1X40 U5737 8.8ZN
10	F01220011R	DADO M6X1 D980 8ZN	NUT M6X1 D980 8ZN	ECROU M6X1 D980 8 ZN	MUTTER M6X1 D980 8 ZN	TUERCA M6X1 D980 8 ZN
11	F01020404R	VITE M6X1X20 U5739 8.8ZN	SCREW M6X1X20 U5739 8.8ZN	VIS M6X1X20 U5739 8.8ZN	SCHRAUBE M6X1X20 U5739 8.8ZN	TORNILLO M6X1X20 U5739 8.8ZN
12	F05010819R	CATARIFR.TONDO D60 GIALLO	ROUND REFLECTOR D.60 YELLOW	JAUNE R FLECTEUR ROUND	RUNDFLEKTOR GELB D60	REFLECTOR REDONDO AMARILLO

TAV. 110

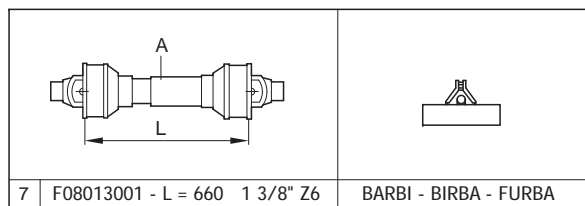

BONDIOLI

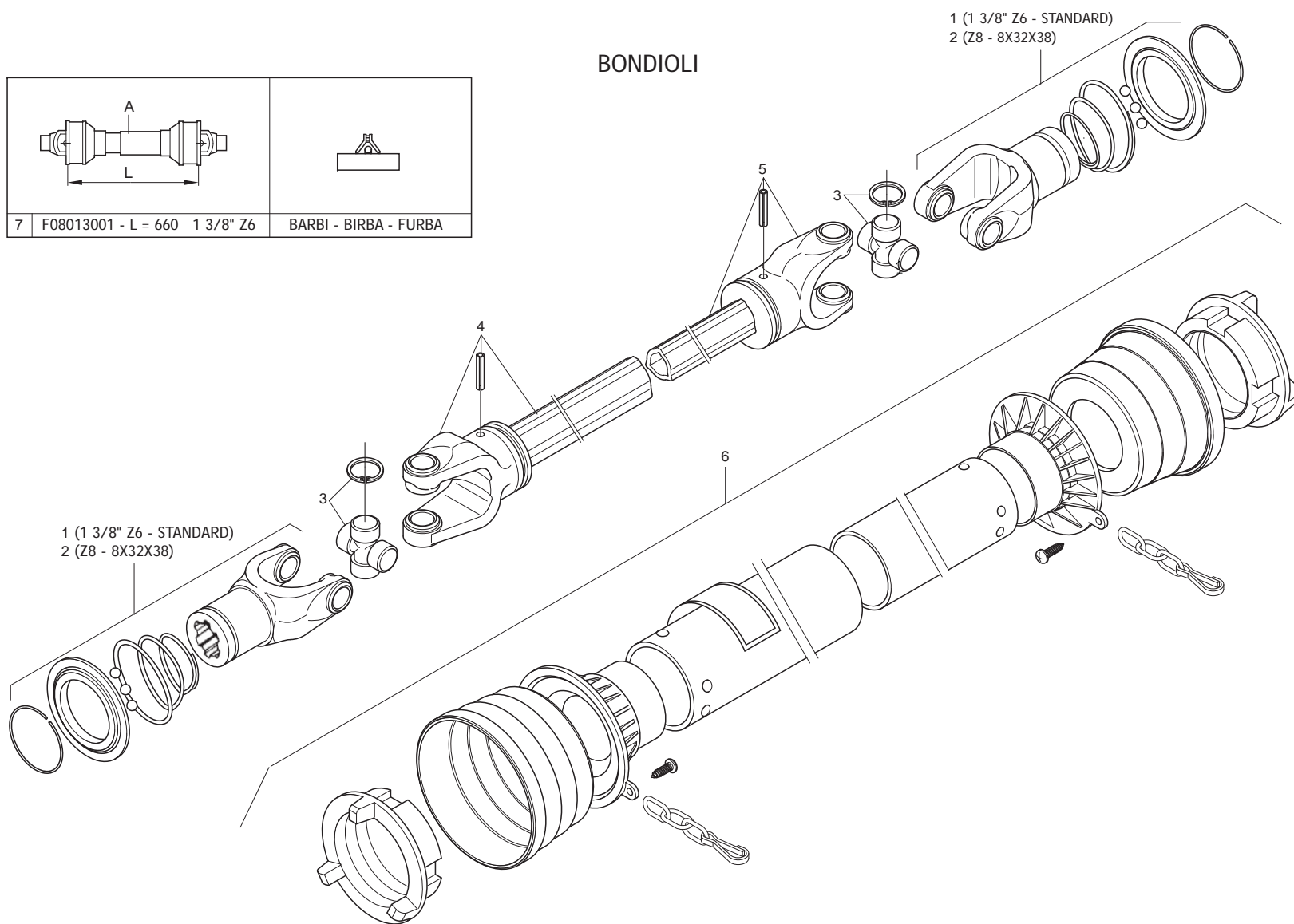

CARDANO / CARDAN SHAFT

TAV. 110

Pos.	Cod.	Descrizione	Description	Benennung	Description	Description
1	F08010166R	BIN.FORCELLA 1 3 8 Z6 0800403	FORK 1 3 8 Z6	FOURCHE AVEC FLASQUE	GABELSTUECK M. FLANSCH	HORQUILLA BRIDA
2	F08012152R	FORCELLA BO Z8 8X32X38 R	FORK BO Z8 8X32X38			
3	F08010699R	CROCIERA COMP.	SPIDER ASSY	CROISIERE COMPL.	GELENKKREUZ KOMPL.	CRUCETA COMPLETA
4	F08010486R	FORCELLA EST. COMPL. DI TUBO	FORK WITH EXTERNAL PIPE	FOURCHE AVEC TUBE EXTERIEUR	GABELST. AUSSENROHR	HORQUILLA TUBO EXTERNO
5	F08010555R	FORCELLA INT. COMPL. DI TUBO	FORK WITH INTERNAL PIPE	FOURCHE AVEC TUBE INT.	GABELST. INNENROHR	HORQUILLA TUBO INT.
6	F08010900R	PROT.COMP.	COMP.PROTECTION	PROTECTION CARDAN	GELENKWELLENSCHUTZ	PROTECCION CARDANICO
7	F08013001R	CAR 30 BO 38Z6 DIR. L872	PTO SHAFT BO 38Z6 DIR. L872			

TAV. 120

WALTERSCHEID (OPTIONAL)

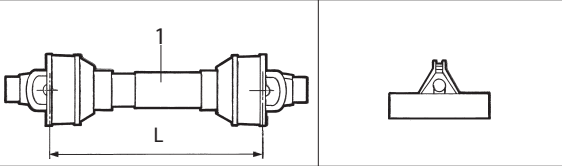
1 F08011585 L= 660
BRAVA BARBI - FURBA

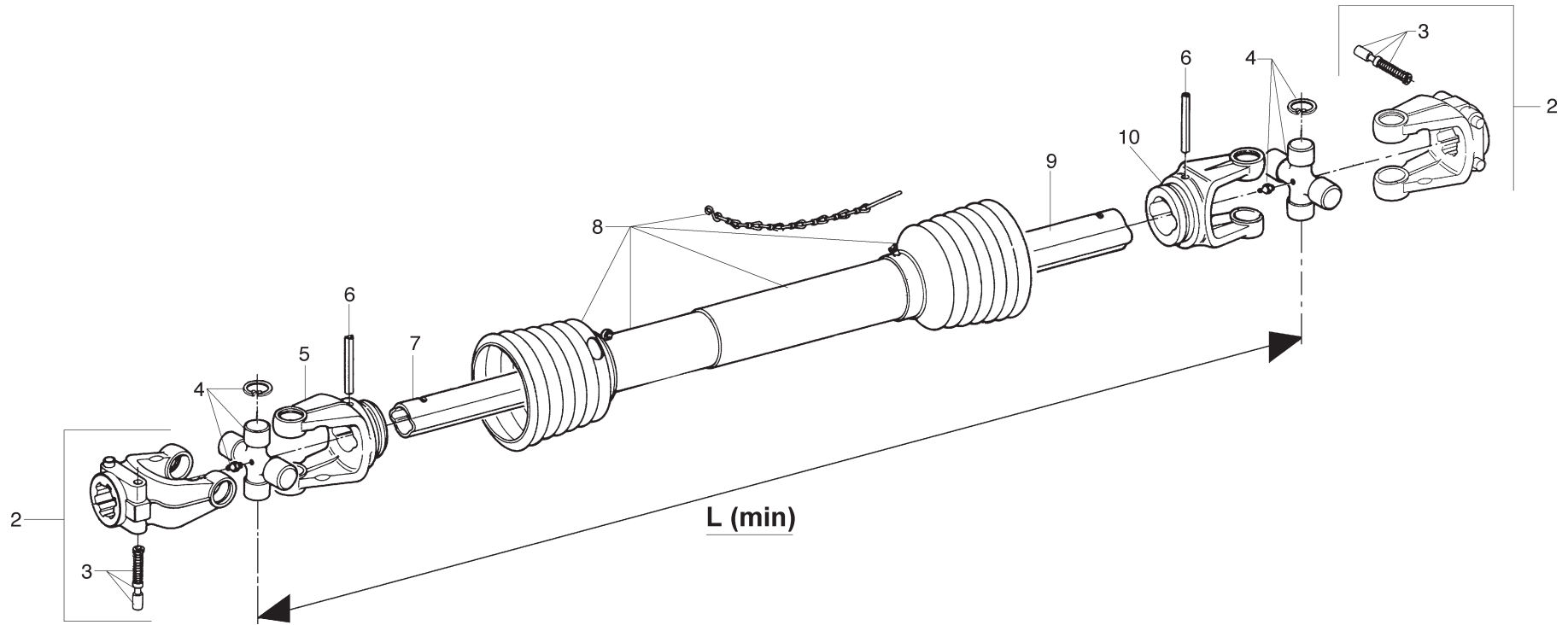

CARDANO WALTERSCHEID / CARDAN SHAFT WALTERSCHEID

TAV. 120

Pos.	Cod.	Descrizione	Description	Benennung	Description	Descripcion
1	F08011585R	CARD.GKN 181864	UNIVERSAL P T O SHAFT	ARBRE A CARDAN	GELENKWELLE	ARBOL CARDANICO
2	F08010465R	FORCELLA COMPLETA DI PULSANTI	LINKAGE FORK	FOURCHE ATTELAGE	GABELSTUECK	HORQUILLA ATAQUE
3	F08011168R	339107 PULSANTE	YOKE PIN 339107	POUSSOIR COMPL.	DRUCKKNOPF KOMPL.	PULSADOR COMPL.
4	F08010675R	CROCIERA COMPLETA	SPIDER ASSY	CROISIERE COMPL.	GELENKKREUZ KOMPL.	GRUCETA COMPLETA
5	F08010605R	FORCELLA PER TUBO INTERNO	FORK FOR INTERNAL PIPE	FOURCHE TUBE INTERIEUR	GABELSTUECK FUER INNENROHR	HORQUILLA TUBO INTERIOR
6	F02100168R	SPINA E.P. 10X 65 U6873 C70 BR	ELASTIC PIN 10X75	GOUJON ELASTIQUE 10X75	SPANNHUELSE 10X75	ESPINA ELASTICA 10X75
7	F08010796R	TUBO INTERNO	INNER TUBE	TUBE PROFILE INTERIEUR	PROFILIERTES INNENROHR	TUBO PERFILADO INTERNO
8	F08010835R	PROTEZIONE COMPLETA	PROTECTION ASSY	PROTECTION COMPL.	KOMPL. SCHUTZ	PROTECCION COMPL.
9	F08010776R	TUBO ESTERNO	OUTER TUBE	TUBE PROFILE EXTERIEUR	PROFILIERTES AUSSENROHR	TUBO PERFILADO EXTERNO
10	F08010615R	FORCELLA PER TUBO ESTERNO	FORK FOR EXTERNAL PIPE	FOURCHE TUBE EXTERIEUR	GABELSTUECK FUER AUSSENROHR	HORQUILLA TUBO EXTERNO

**USATE SEMPRE RICAMBI ORIGINALI
ALWAYS USE ORIGINAL SPARE PARTS
IMMER DIE ORIGINAL-ERSATZTEILE VERWENDEN
EMPLOYEZ TOUJOURS LES PIECES DE RECHANGE ORIGINALES
UTILIZAR SIEMPRE REPUESTOS ORIGINALES**



**Servizio Assistenza Tecnica - After Sales Service
Servizio Ricambi - Spare Parts Service
+39 049 9289888**

DEALER:



MASCHIO GASPARDO SpA
Registered Office and Production Plant
Via Marcello, 73 - 35011 Campodarsego (Padova) - Italy
Tel. +39 049 9289810
Fax +39 049 9289900
info@maschio.com
www.maschionet.com

MASCHIO DEUTSCHLAND GMBH
Äußere Nürnberger Straße 5
D - 91177 Thalmässing - Deutschland
Tel. +49 (0) 9173 79000
Fax +49 (0) 9173 790079
dialog@maschio.de
www.maschionet.de

MASCHIO FRANCE Sarl
1 rue Denis Papin ZA
F - 45240 La Ferte St. Aubin
France
Tel. +33 (0) 2.38.64.12.12
Fax +33 (0) 2.38.64.66.79
info@maschio.fr

ООО МАСКИО-ГАСПАРДО РУССИЯ
04130, Россия,
Волгоградская область,
г. Волжский, ул. Пушкина, 117 «б».
Тел.: +7 8443 203100
факс: +7 8443 203101
e-mail: info@maschio.ru

MASCHIO GASPARDO SpA
Production Plant
Via Mussons, 7 - 33075 Morsano al Tagliamento (PN) - Italy
Tel. +39 0434 695410
Fax +39 0434 695425
info@gaspardo.it

MASCHIO GASPARDO NORTH AMERICA Inc.
112 3rd Avenue East
DeWitt - IA 52742
Ph. +1 563 6596400
Fax +1 563 6596404
info@maschio.us

MASCHIO-GASPARDO ROMANIA S.R.L.
Strada Înfrăţirii, F.N.
315100 Chisineu-Cris (Arad) -România
Tel. +40 257 307030
Fax +40 257 307040
info@maschio.ro

MASCHIO IBERICA S.L.
MASCHIO-GASPARDO POLAND
MASCHIO-GASPARDO UCRAINA
GASPARDO-MASCHIO TURCHIA
MASCHIO-GASPARDO CINA
MASCHIO-GASPARDO INDIA
MASCHIO-GASPARDO KOREA