

**MASCHIO GASPARDO S.p.A.**

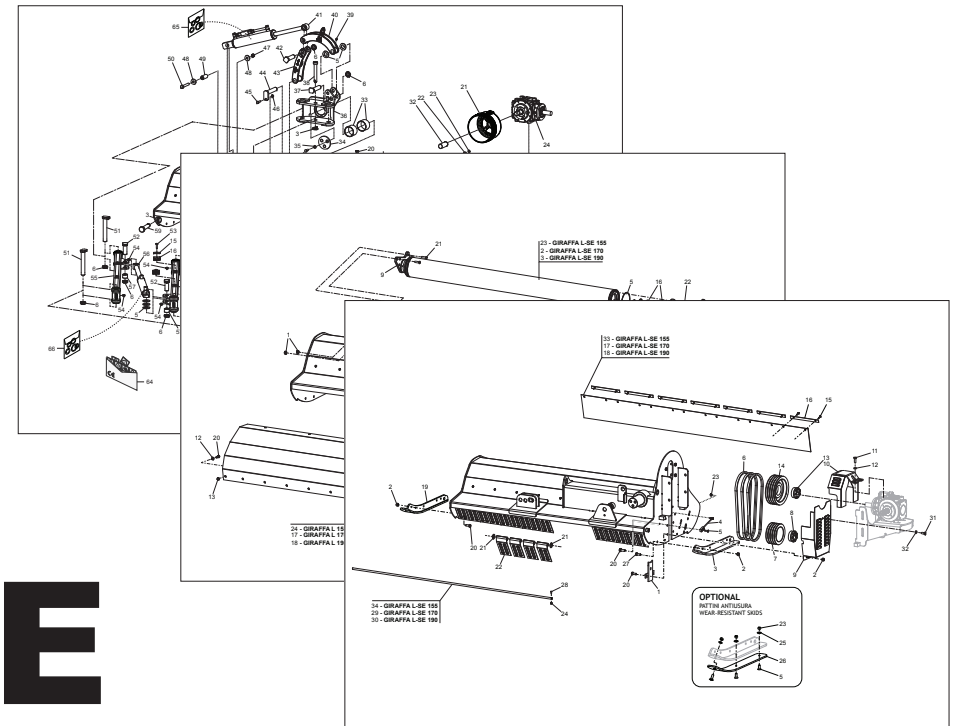

# GIRAFFA L-SE

**Cod: F07011645 2019-06**

- \*) Valido per Paesi UE
- \*) Valid for EU member countries
- \*) Valable dans les Pays UE
- \*) Gilt für EU-Mitgliedsländer
- \*) Válido para Países UE

- IT** PARTI DI RICAMBIO
- EN** SPARE PARTS
- DE** ERSATZTEILE
- FR** PIÈCES DÉTACHÉES
- ES** PIEZAS DE REPUESTO

ITALIANO	ENGLISH	DEUTSCH	FRANÇAIS	ESPAÑOL
<b>PARTI DI RICAMBIO</b>	<b>SPARE PARTS</b>	<b>ERSATZTEILE</b>	<b>PIECES DÉTACHÉES</b>	<b>RESPUESTOS</b>
Le ordinazioni delle parti di ricambio vanno fatte presso i nostri concessionari di zona e devono essere sempre corredate dalle seguenti indicazioni:	<i>Orders must be transmitted through our area dealers and should always include the following indications:</i>	Die Bestellungen müssen bei unseren Gebietshändlern aufgegeben werden. Bei der Bestellung sind stets die folgenden Angaben zu machen:	<i>Les ordres doivent être effectués auprès de nos concessionaires de zone en précisant les indications suivantes:</i>	Los pedidos han de efectuarse en nuestros concesionarios de zona y deben incluir siempre las siguientes indicaciones:
- <b>Tipo, modello e numero di matricola dell'attrezzatura.</b> Tali dati sono stampigliati nell'apposita targhetta di cui è dotata ogni attrezzatura.	- <b>Type, model and serial number of the machine.</b> <i>These data are punched on the data plate with which every implement is equipped.</i>	- <b>Typ, Modell und Serien-Nummer des Geräts.</b> Diese Daten stehen auf dem Typenschild, mit dem jedes Gerät versehen ist.	- <b>Type, modèle et numéro de série de la machine.</b> <i>Ces données sont gravées sur la plaque d'identification de chaque outil.</i>	- <b>Tipo, modelo y número de matrícula del equipo.</b> Dichos datos están impresos en la relativa placa presente en el equipo.
- <b>Numero di codice della parte richiesta</b> rilevabile dal catalogo ricambi.	- <b>Code number of the required spare part.</b> <i>This will be found in the spare parts catalogue.</i>	- <b>Artikel Nr. der erforderlichen Ersatzteile.</b> Diese stehen im Ersatzteil-Katalog.	- <b>Numéro de code de la pièce détachée</b> indiqué sur le catalogue des pièces détachées.	- <b>Número de código de la parte requerida</b> presente en el catálogo respuestas.
- <b>Descrizione del particolare e quantità richiesta.</b>	- <b>Description of the part and required quantity.</b>	- <b>Beschreibung des Ersatzteils und die erforderliche Stückzahl.</b>	- <b>Description de la pièce et quantité requise.</b>	- <b>Descripción de la pieza y cantidad requerida.</b>
- <b>Numero della tavola.</b>	- <b>Table number.</b>	- <b>Tafelnummer.</b>	- <b>Numéro de plan.</b>	- <b>Numero de ilustración.</b>
- <b>Mezzo di trasporto.</b> Nel caso questa voce non sia specificata, la Ditta Costruttrice, pur dedicando a questo servizio una particolare cura, non risponde di eventuali ritardi di spedizione dovuti a cause di forza maggiore. Le spese di trasporto si intendono sempre a carico del destinatario. La merce viaggia a rischio e pericolo del committente anche se venduta franco destino.	- <b>Means of dispatch.</b> <i>If this item is not indicated, the Manufacturer, while dedicating particular care to this service, shall not be held responsible for delays in delivery caused by cases of force majeure. Transport expenses shall always be at the consignee's charge. The goods travel at the purchaser's risk and peril even when sold ex destination.</i>	- <b>Versandmittel.</b> Wenn dieser Punkt nicht spezifiziert wird, haftet die Herstellerfirma nicht für etwaigen Lieferverzug aufgrund höherer Gewalt, auch wenn er diesen Service besonders aufmerksam abwickelt. Die Frachtkosten gehen dagegen immer zu Lasten des Empfängers. Die Ware reist auf Gefahr und Risiko des Auftraggebers, auch wenn frei Haus Verkauft vereinbart worden ist.	- <b>Moyen d'expédition.</b> <i>Si cette rubrique n'est pas indiquée, le Constructeur, bien que soucieux de ce service, ne répond pas des retards d'expédition pour des causes de force majeure. Les frais de transport sont toujours à la charge du destinataire. La marchandise voyage aux risques et périls de l'acheteur même si vendue franco de port.</i>	- <b>Medio de transporte.</b> En caso que este ítem no esté especificado, el Fabricante, aún prestando la debidas consideraciones para este aspecto, no responde por eventuales retardos de env'o debidos a causas de fuerza mayor. Los gastos de transporte se consideran siempre a cargo del destinatario. La mercadería viaja bajo riesgo y peligro del comprador, incluso cuando se vende franco destino.
<b>NOTA:</b> Il termine <b>(Dx) Destro</b> o <b>(Sx) Sinistro</b> della macchina o di parti di essa, è inteso guardando la macchina dalla parte posteriore. Le eccezioni saranno indicate.	<b>NOTE:</b> <i>The symbols (Dx) right and (Sx) left, concerning the machine or single parts of it, are referred, as in the figure, to a rear view of them. Exceptions will be indicated.</i>	<b>N.B.:</b> Die Merkzeichen <b>(Dx) rechts</b> und <b>(Sx) links</b> betreffen eine rückwärtige Aussicht der Maschine oder Teile von ihr (siehe Bild). Ausnahmen werden gezeigt.	<b>N.B.:</b> <i>Les références (Dx) droit et (Sx) gauche de la machine ou des parties de la même, est entendue, comme de la figure, en regardant la machine de derriere dans le sens de marche.</i>	<b>N.B.:</b> La referencia <b>(Dx) derecha</b> o <b>(Sx) izquierda</b> de la máquina o de sus componentes, se entiende, como en la figura, mirando la máquina por la parte trasera. Se indicarán las excepciones.

**INDICE**

<b>N° Tavola</b>	<b>Descrizione</b>	<b>Pagina</b>
TAV.010	TELAIO E TERZO PUNTO .....	5
TAV.020	TRASMISSIONE LATERALE E PROTEZIONI .....	9
TAV.040	ROTORE .....	13
TAV.050	MOLTIPLICATORE .....	15
TAV.060	IMPIANTO IDRAULICO .....	17
TAV.070	SUPPORTI TABELLE STRADALI .....	19
TAV.080	KIT TABELLE STRADALI G99600020 .....	21
TAV.090	KIT TABELLE STRADALI G99600021 .....	23
TAV.100	CARDANO F08012317 .....	25
TAV.110	CARDANO F08011608 .....	27
TAV.120	CARDANO OMOCINETICO WALTERSCHEID .....	29

**INDEX**

<b>N° Table</b>	<b>Description</b>	<b>Page</b>
TAV.010	FRAME AND 3rd POINT HITCH .....	5
TAV.020	SIDE TRANSMISSION AND EC PROTECTIONS .....	9
TAV.040	ROTOR .....	13
TAV.050	OVERDRIVE UNIT .....	15
TAV.060	HYDRAULIC PLANT .....	17
TAV.070	ROAD KIT SUPPORTS .....	19
TAV.080	ROAD TRANSPORT KIT G99600020 .....	21
TAV.090	ROAD TRANSPORT KIT G99600021 .....	23
TAV.100	F08012317 CARDAN SHAFT .....	25
TAV.110	F08011608 CARDAN SHAFT .....	27
TAV.120	WALTERSCHEID CONSTANT VELOCITY PTO SHAFT .....	29

**TAV.010**

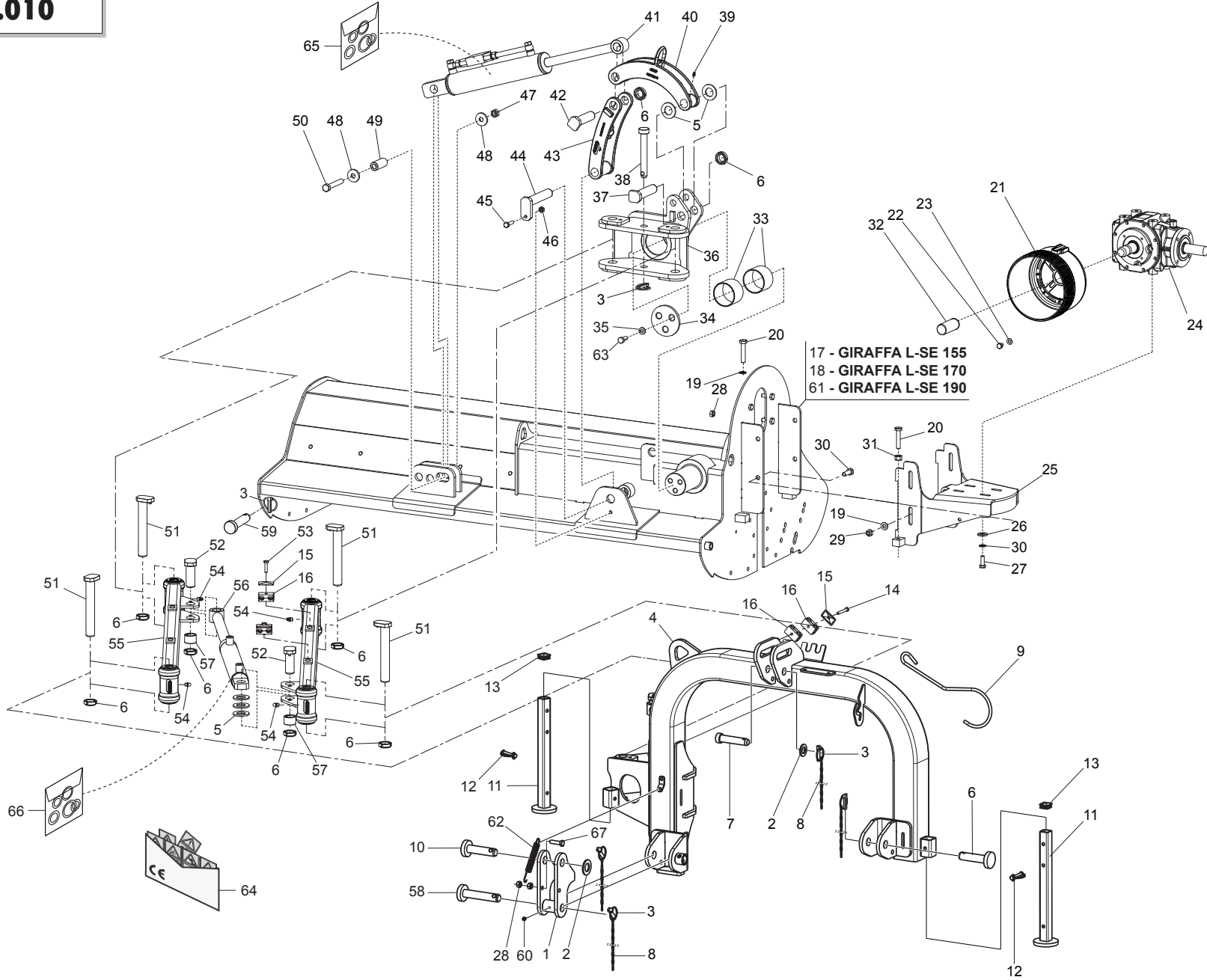

**TELAIO E TERZO PUNTO  
FRAME AND 3rd POINT HITCH**

**TAV.010**

Pos.	Cod.	Descrizione	Description	Description	Benennung	Descripcion
1	M55700712R	BIELLA ATTACCO BARRE	BAR CONNECTION ROD			
2	F01410147R	ROS.M24 25X 44X 4 U6592 ZN	WASHER M24 25X44X 4 U6592 ZN	RONDELLA M24 25X44X4 U6592 ZN	SCHEIBE M24 25X44X4 U6592 ZN	ARANDELLA M24 25X44X4 U6592 ZN
3	F02200529R	SPINA SCATTO D.11 H58 ZN	SNAP PIN D.11 H58 ZN	FICHE A DETENTE D.11 H58 ZN	EINRASTSTIFT D.11 H58 ZN	CLAVIJA DE MUELLE D.11 H58 ZN
4	M55700701R	CASTELLO 3 PUNTO	CASTLE 3 POINT			
5	F01410168R	ROS.M30 31X 56X 4 U6592 ZN	WASHER M30 31X56X4 U6592 ZN	RONDELLA M30 31X56X4 U6592 ZN	SCHRAUBE M30 31X56X4 U6592 ZN	ARANDELLA M30 31X56X4 U6592 ZN
6	F02010111R	GHIERA AU.GUP M30X1,5 T.4H ZN	SELF LOCKING NUT M30X1,5	COLLIER AUTOBL. M30X1,5	SELBSTSP. NUTMUTTER M30X1,5	VIROLA AUTOBL. M30X1,5
7	F20100063R	PERNO D25 L91 C43 TEST.D35 ZN	PIN D25 L91 C43 ZN	BOULON D25 L91 C43 ZN	BOLZEN D25 L91 C43 ZN	PERNO D25 L91 C43 ZN
8	M58100930R	CATENELLA L=476	ASSEMBLY CHAIN DMP L=476	CHAINE L=476	KETTE L=476	CADENA L=476
9	F20120400R	GANCIO SOSTEGNO CARDANO	SHAFT HOOK SUPPORT	SUPPORT CARDAN	GELENKWELLE - HACKEN	SOPORTE CARDAN
10	F20100135R	PERNO D28 L 93 C43 TEST.D60 ZN	PIN D28 L93 C43 GALV.ED			
11	M56400922R	COMP. PIEDINO L=424,3	SUPPORT ASSEMBLY L=424,3	SUPPORT L=424,3	STANDER L=424,3	SOPORTE L=424,3
12	F02200562R	SPINA SICUR.D. 8X70 ZN	SNAP PIN D.8X 70 ZN	FICHE EL. D.8X70 ZN	SCHERSTIFT D.8X 70 ZN	CLAVIJA D.8X 70 ZN
13	F05100025R	TAPPO AD ALETTE 35X35 PLT NERO	PLUG	BOUCHON FERMETURE	VERSCHLUSSPFROPFEN	TAPONCLAUSURA
14	F01020082R	VITE M8X1,25X65 U5737 8.8ZN	SCR. M8X1,25X65 U5737 8.8ZN	VIS M8X1,25X65 U5737 8.8 ZN	SCHRA. M8X1,25X65 U5737 8.8 ZN	TORN. M8X1,25X65 U5737 8.8 ZN
15	M58100628R	PIATTO SUPERIORE ZPG	UPPER PLATE	PLAT SUPERIEUR	OBENE PLATTE	PLATO SUPERIOR
16	F03151019R	COPPIA COLL.2T D12 1V I=00 M8	COLLAR PAIR 2T D12 1V I=00 M8			
17	M55715526R	GIRAFFA L SE TELAI0 SALDATO	GIRAFFA L SI WELDED FRAME			
18	M55717526R	GIRAFFA L SE TELAI0 SALDATO	GIRAFFA L SE WELDED FRAME			
19	F01410088R	ROS.M14 15X 28X2,5 U6592 ZN	WAS.M14 15X 28X2,5 U6592 ZB	RON.M14 15X 28X2,5 U6592 ZB	SCH.M14 15X 28X2,5 U6592 ZB	ARA.M14 15X 28X2,5 U6592 ZB
20	F01010323R	VITE M14X1,5X70 U5740 8.8ZN	SCR. M14X1,5X70 U5740 8.8ZN	VIS M 14X1,5X70	SCHRAUBE M 14X1,5X70	TORNILLO M 14X1,5X70
21	F08011962R	PROTEZIONE CE SMONTABILE	REMOVABLE COUNTER CAP			
22	F01020432R	VITE M8X1,25X16 U5739 8.8ZN	SCR. M8X1,25X16 U5739 8.8ZN	VIS M8 X1,25X16 U5739 8.8 ZN	SCHRAUBE M8X1,25X16U5739 8.8ZN	TORNILLO M8X1,25X16 U5739 8.8
23	F01410051R	ROS.M8 8,4X 17X1,6 U6592 ZN	WASHER M8 8,4X17X1,6 U6592 ZN	RONDELLE M8 8,4X17X1,6 ZN	SCHEIBE M8 8,4X17X1,6 U6592 ZN	ARAND.M8 8,4X 17X1,6 U6592 ZN
24	M30400201R	MULTIPLICATORE 540 RPM	MULTIPLIER 540 RPM			
25	M30400528R	COMP. ATTACCO SCATOLA GF	BOX LINKAGE			
26	F01500011R	ROS. 13 X35X5 D6340 C50 ZN	WASHER D. 12	RONDELLE D.12	SCHEIBE D.12	ARANDELA D.12
27	F01010288R	VITE M12X1,25X35 U5740 8.8ZN	SCR. M12X1,25X35 U5740 8.8ZN	VIS M12X1,25X35 U5740 8.8 ZN	SCHR.M12X1,25X35 U5740 8.8 ZN	TORN.M12X1,25X35 U5740 8.8 ZN
28	F01220047R	DADO M12X1,25 D980 8ZN	NUT M12X1,25 D980 8ZN	ECROU M12X1,25 D980 8 ZN	MUTTER M12X1,25 D980 8 ZN	TUERCA M12X1,25 D980 8 ZN
29	F01220059R	DADO M14X1,5 D980 8ZN	NUT M14X1,5 D980 8ZN	ECROU M14X 1,5 D980 8 ZN	MUTTER M14X 1,5 D980 8 ZN	TUERCA M14X 1,5 D980 8 ZN
30	F01010318R	VITE M14X1,5X40 U5740 8.8ZN	SCR. M14X1,5X40 U5740 8.8ZN	VIS M 14X1,5X40	SCHRAUBE M 14X1,5X40	TORNILLO M 14X1,5X40
31	F01200089R	DADO M14X1,5 U5587 CL8 ZNN6SZN	NUT M14X1,5 U5587 6SZN	ECROU M14X 1,5 U5587 6S ZB	MUTTER M14X 1,5 U5587 6S ZB	TUERCA M14X 1,5 U5587 6S ZB
32	M38100146R	MANICOTTO PROTEZIONE PDF 1 3 8	P.T.O. PROTECTION	MANCHON DE PROTECTION P.T.O.	ZAPFWELLENSCHUTZ P.T.O.	MANGUITO PROTECCION P.T.O.
33	F04100105R	BOCCOLA D=85 D=80 L=60 AUTOLUB	BUSHING D=85 D=80 L=60	BOUCLE D=85 D=80 L=60	BUECHSE D=85 D=80 L=60	ARANDELA D=85 D=80 L=60
34	M07400748R	ROSETTA DI BLOCCAGGIO	WASHER CLAMPING			
35	F01480145R	ROS.G 17X29 X 5 FLZNNC-240H	GROWER WASHER 17X29	RONDELLE GROWER 17X29	SCHEIBE GROWER 17X29	ARANDELA GROWER 17X29
36	M07400709R	GIUNTO MOVIMENTAZIONE	JOINT	JOINT	VERBINDUNG	JUNTA
37	M07400592R	COMP.PERNO D=30 L=119	PIN	GOUJON	STIFT	PERNO
38	F20100115R	PERNO D22 L144 C40 TEST.D35 ZN	GASPARDO PIN 22X144 ZN	GOUPILLE GASPARDO 22X144 ZN	GASPARDO-STIFT 22X144 ZN	PASADOR GASPARDO 22X144 ZN
39	F01100011R	ING.M 6X1 7663-A 9SMNPB28 ZN	GREASE NIPPLE M6X1 7663-A ZN	GRAISS. A BILLE M6X1 7663A ZN	SCHMIERBUECHE M6X1 7663-A ZN	ENG.M 6X1 7663-A 9SMNPB28 ZN
40	M30400546R	BIELLA	UPPER CONNECTION ROD	BIELLE ATTELAGE	PLEUELSTANGE	BIELA ATAQUE
41	F03100116R	SERIE GUARNIZ.CILID.M07400989	GASKET SET M07400989*			
42	M07400598R	COMP.PERNO D=30 L=109	PIN D=30 L=109	GOUJON D=30 L=109	STIFT D=30 L=109	PERNO D=30 L=109
43	M06700515R	BIELLA INFERIORE SENZA FERMO	LOWER ROD WITHOUT BLOCK			
44	M07400596R	COMP.PERNO D=30 L=150	PIN	GOUJON	STIFT	PERNO
45	F01010026R	VITE M10X1,25X40 U5738 8.8ZN	SCR. M10X1,25X40 U5738 8.8ZN	VIS M 10X1,25X40	SCHRAUBE M 10X1,25X40	TORNILLO M 10X1,25X40
46	F01220034R	DADO M10X1,25 D980 8ZN	NUT M10X1,25 D980 8ZN	ECRO.M10X1,25 D980 8 ZB	MUTT.M10X1,25 D980 8 ZB	TUER.M10X1,25 D980 8 ZB
47	F01220070R	DADO M16X1,5 D980 10ZN	NUT M16X 1,5 D980 10 ZN 8ZN	ECRO.M16X1,5 D980 8ZN	MUTTER M16X1,5 D980 8ZN	TUER.M16X1,5 D980 8ZN
48	F01500023R	ROS. 17 X45X6 D6340 C50 ZD	ELASTIC DISK	DISQUE ELASTIQUE	ELASTISCHE SCHEIBE	DISCO ELASTICO
49	M50400556R	DISTANZIALE D=30 D=20 L=65	SPACER D=30 D=20 L=65	ENTRETOISE D=30 D=30 L=65	DISTANZST.D=30 D=20 L=65	DISTANCIAD.D=30 D=20 L=65
50	F01010124R	VITE M16X1,5X100 U5738 8.8ZN	SCR. M16X1,5X100 U5738 8.8ZN	VIS M16X1,5X100	SCHRAUBE M16X1,5X100	TORNILLO M16X1,5X100
51	M07400726R	PERNO D=30 L= 199	PIN D=30 L= 199	GOUJON D=30 L= 199	BOLZEN D=30 L= 199	PERNO D=30 L= 199
52	M07700539R	PERNO D=30 L=109	PIN D=30 L=109			
53	F01020449R	VITE M8X1,25X35 U5739 8.8ZN	SCR. M8X1,25X35 U5739 8.8ZN	VIS M8X1,25X35 U5739 8.8ZN	SCHRA. M8X1,25X35 U5739 8.8ZN	TORN. M8X1,25X35 U5739 8.8ZN
54	F01100063R	ING.M10X1 7663-C 9SMNPB28 ZN	INGREASE NIPPLE M10X1 7663	ING.M10X1 7663-C 9SMNPB28 ZN	ING.M10X1 7663-C 9SMNPB28 ZN	ING.M10X1 7663-C 9SMNPB28 ZN
55	M30400918R	PARALLELOGRAMMA	PARALLELOGRAM			
56	M07400588R	COMP. MART.IDR.A=50 C=314 L616	CYLINDER A=50 C=314 L=616	VERIN	SPINDELVERSTELLUNGSTEIL	MARTINETE

# TAV.010

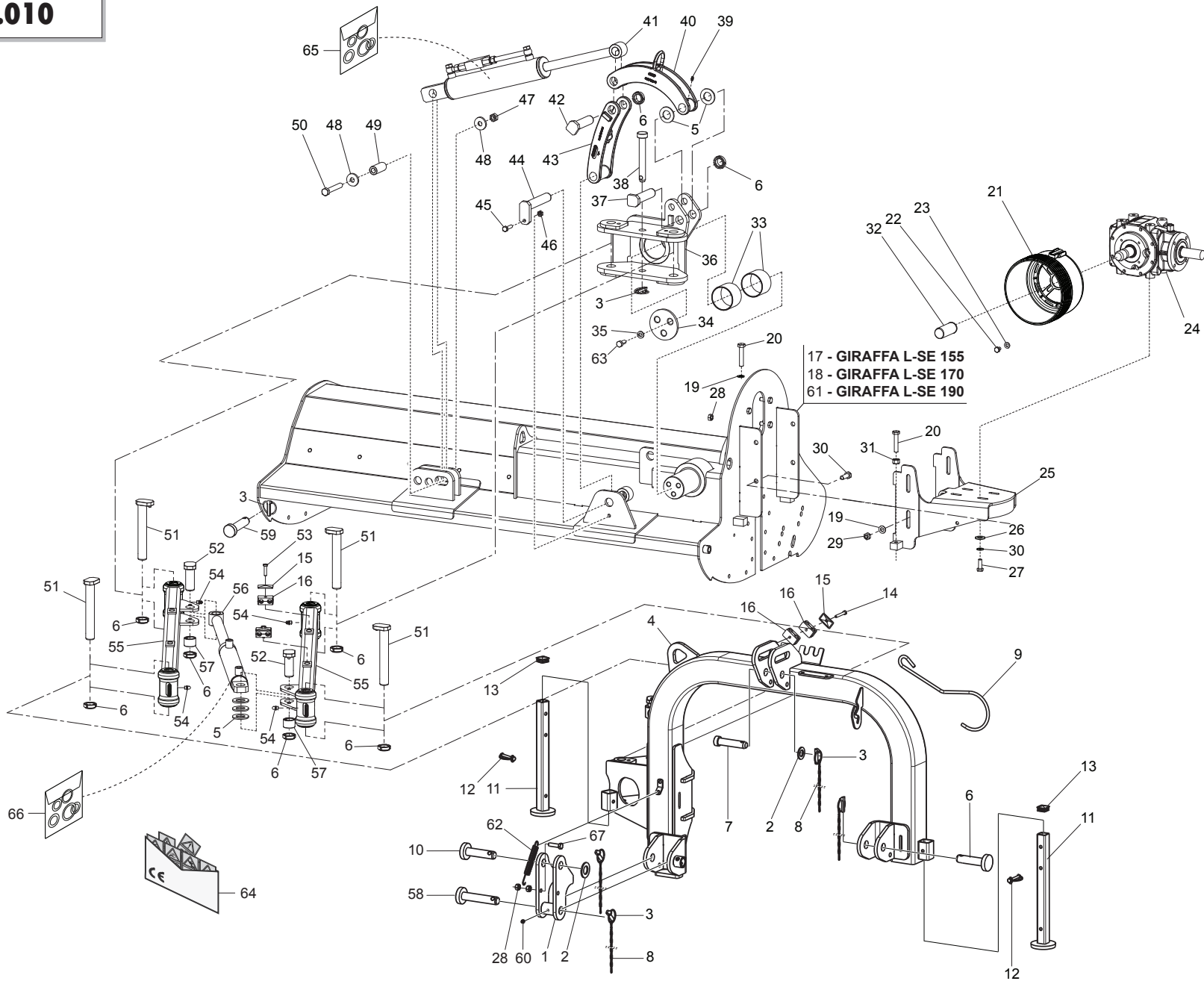

**TELAIO E TERZO PUNTO  
FRAME AND 3rd POINT HITCH**

**TAV.010**

Pos.	Cod.	Descrizione	Description	Description	Benennung	Descripcion
57	M23400529R	ROSETTA D=48,3 D=32,5 L=22	WASHER D=48,3 D=32,5 L=22	ROSETTE D=48,3 D=32,5 L=22	SCHEIBE D=48,3 D=32,5 L=22	ARANDELLA D=48,3 D=32,5 L=22
58	F20100137R	PERNO D28 L124 C43 TEST.D60 Z	PIN D28 L124 C43 ZN	BOULON D28 L124 C43 ZN	BOLZEN D28 L124 C43 ZN	PERNO D28 L124 C43 ZN
59	F20100074R	PERNO D28 L109 C43 SPINA 3 P.	PIN FOR BAR LINKAGE	GOUJON ATTELAGE BARRE	VERB.BOLZEN SCHUTZHOLM	PERNO ATAQUE BARRA
60	F01100048R	ING.M 8X1,25 7663A 9SMNPB28 Z	GREASE NIPPLE M8X1,25 U7663A	GRAISSEUR A BILLES M8X1,25	SCHMIERBUECHSE M8X1,25 7663A	ENG.M 8X1,25 7663A 9SMNPB28 Z
61	M55719526R	GIRAFFA L SE TELAIO SALDATO	GIRAFFE L SE WELDED FRAME			
62	M34100530R	MOLLE X PROLUNGA L.LIV.	LEVELL.BONNET SPRING EXTENSION	EXTENSION RESSORT LAME NIVELL.	FEDER	RESORTE PROLONGA CHAPA NIVELL.
63	F01010341R	VITE M16X1,5X45 U5740 8.8ZN	SCR. M16X1,5X45 U5740 8.8ZN	VIS M16X1,5 X45 U5740 8.8 ZN	SCHR.M16X1,5 X45 U5740 8.8 ZN	TORN.M16X1,5 X45 U5740 8.8 ZN
64	F20030241R	KIT.ET.CE TRINCIA	KIT CE LABELS MULCHERS			
65	F03100116R	SERIE GUARNIZ.CILID.M07400989	GASKET SET M07400989*			
66	F03100068R	SERIE GUAR.M07400588-M26400416	GASKET SET M07400588	SERIE JOINTS M07400588	DICHTUNGSSATZ M07400588	SERIE JUNTAS M07400588
67	F01010292R	VITE M12X1,25X45 U5740 8.8ZN	BOLT M12X1,25X45 U5740 8.8ZN	VIS M12X1,25X45 U5740 8.8ZN	SCHRA.M12X1,25X45 U5740 8.8ZN	TORN. M12X1,25X45 U5740 8.8ZN

# TAV.020

33 - GIRAFFA L-SE 155  
 17 - GIRAFFA L-SE 170  
 18 - GIRAFFA L-SE 190

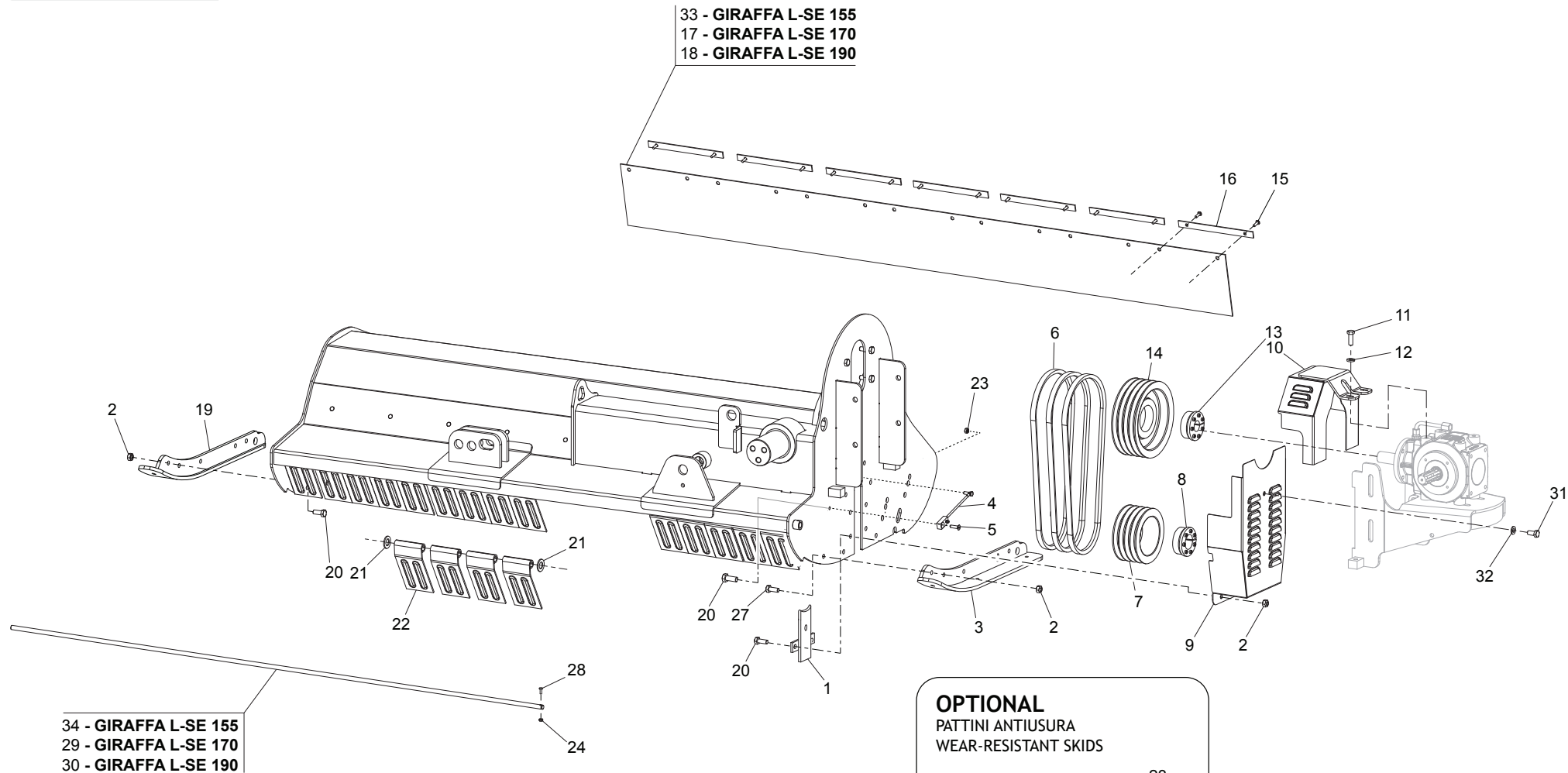

**OPTIONAL**  
 PATTINI ANTIUSURA  
 WEAR-RESISTANT SKIDS



**TRASMISSIONE LATERALE E PROTEZIONI  
SIDE TRANSMISSION AND EC PROTECTIONS**

**TAV.020**

Pos.	Cod.	Descrizione	Description	Description	Benennung	Description
1	M55700515R	PIATTO DI CHIUSURA	CLOSING PLATE			PLACA DE CIERRE
2	F01220047R	DADO M12X1,25 D980 8ZN	NUT M12X1,25 D980 8ZN	ECROU M12X1,25 D980 8 ZN	MUTTER M12X1,25 D980 8 ZN	TUERCA M12X1,25 D980 8 ZN
3	M55700103R	SLITTA GIRAFFA L SX	GIRAFFA L SLEIGH SX			PATIN GIRAFFA L SX
4	T24004000R	ASSIEME INGRASSATORE	GREASE NIPPLE	GRAISSEUR	SCHMIERNIPPEL	ENGRASADOR
5	F01030058R	VITE M8X1,25X30 U5933 10.9ZD	SCR. M8X1,25X30 U5933 10.9ZD	VIS M8 X1,25 X30 U5933 10,9 ZD	SCHRAUBE M8X1,25X30 U5933 10,9	TORNILLO M8X1,25X30 U5933 10,9
6	F06010114R	CINGHIA SPB L.= 1320	BELT SPB 1320	COURROIE SPB 1320	SCHAUBE SPB 1320	CORREA SPB 1320
7	T22003001R	PULEGGIA ROTORE DP=160	DRIVING PULLEY	POULIE TIRANTE	ZIEHEN RIEMEN	ROLDANA DE TIRAR
8	F06060037R	CALETTATORE AUTOCENTR.35X80	SELF CENTR.CLAMP.EL.35X80	EMBOITAGE AUOBL. 35X80	SELBSTPERR.VERKEILEN 35X80	ENSAMBLADURA AUTOBL. 35X80
9	M07400934R	CARTER BASSO	CARTER	CARTER	GEHAEUSE	CARTER
10	M07400932R	CARTER ALTO	CARTER	CARTER	GEHAEUSE	CARTER
11	F01020512R	VITE M12X1,75X35 U5739 8.8ZN	SCR. M12X1,75X35 U5739 8.8ZN	VIS M12X1,75X35 5739 8.8 ZN	SCHR. M12X1,75X35 5739 8.8 ZN	TORNILLO M12X1,75X35 U5739 8
12	F01480123R	ROS.G 12,5X22,9X 4 FLZNNC-240H	WASHER M12 ZGP EXTRA P.	UNTERLEGSCHEIBE M12 ZGP EXTRA P.		TORNILLO M12 ZGP EXTRA P.
13	F06060036R	CALETTATORE AUTOC. 33X80	SELF CENTR.CLAMP.EL.33X80	EMBOITAGE AUOBL. 33X80	SELBSTPERR.VERKEILEN 33X80	ENSAMBLADURA AUTOBL. 33X80
14	T16003002R	PULEGGIA SPB MOTRICE D=225 3V	DRIVING PULLEY	POULIE TIRANTE	ZIEHEN RIEMEN	ROLDANA DE TIRAR
15	F02250160R	RIVETTO STR. 6,4X22 ACCIAIO	RIVET	RIVET	KUPFERNIET	REMACHE
16	M07400953R	PIATTO PER ATTACCO GOMMA	PLATE	PLAT	PLATTE	PLATO
17	T24175681R	PROTEZ. POSTERIORE PVC L=1680	REAR GUARD PVC L=1681			
18	T24195681R	PROTEZ. POSTERIORE PVC L=1880	REAR GUARD PVC L=1880			
19	M55700104R	SLITTA GIRAFFA L DX	GIRAFFA L SLEIGH DX			PATIN GIRAFFA L DX
20	F01010283R	VITE M12X1,25X30 U5740 8.8ZN	SCR. M12X1,25X30 U5740 8.8ZN	VIS M 12X1,25X30	SCHRAUBE M 12X1,25X30	TORNILLO M 12X1,25X30
21	F01410100R	ROS.M16 17X 30X 3 U6592 ZN	WASHER M16 17X30X3 U6592 ZN	RONDELLE M16 17X30X3 ZN	SCHRAUBE M16 17X 30X3 U6592 ZN	ARANDELA M16 17X 30X 3 U6592 ZN
22	M24400518R	BANDELLA PROTEZ. 93X170 ZG	PROTECTION BAR	BANDE PROTECTION	SCHUTZWORNE	ALETA PROTECCION
23	F01220022R	DADO M8X1,25 D980 8ZN	NUT M8X1,25 D980 8ZN	ECROU M8X 1,25 D980 8 ZN	MUTTER M8X 1,25 D980 8 ZN	TUERCA M8X 1,25 D980 8 ZN
24	F01220011R	DADO M6X1 D980 8ZN	NUT M6X1 D980 8ZN	ECROU M6X1 D980 8 ZN	MUTTER M6X1 D980 8 ZN	TUERCA M6X1 D980 8 ZN
25	F01410051R	ROS.M8 8,4X 17X1,6 U6592 ZN	WASHER M8 8,4X17X1,6 U6592 ZN	RONDELLE M8 8,4X17X1,6 ZN	SCHRAUBE M8 8,4X17X1,6 U6592 ZN	ARANDELA M8 8,4X 17X1,6 U6592 ZN
26	M50400778R	SLITTA ANTIUSURA OPTIONAL	NO WEAR SKID OPTIONAL			
27	F01010288R	VITE M12X1,25X35 U5740 8.8ZN	SCR. M12X1,25X35 U5740 8.8ZN	VIS M12X1,25X35 U5740 8.8 ZN	SCHR.M12X1,25X35 U5740 8.8 ZN	TORN.M12X1,25X35 U5740 8.8 ZN
28	F01040066R	VITE M6X1X35 U5931 8.8ZN	SCREW M6X1X35 U5931 8.8ZN	VIS M6X1X35 U5931 8.8ZN	SCHRAUBE M6X1X35 U5931 8.8ZN	TORNILLO M6X1X35 U5931 8.8ZN
29	T24175085R	ASTA BANDELLE CR 170	PROTECTION FLAP BAR CR170	TIGE PALETTE PROTECTION CR170	DAS TURBAND STANGE CR170	VARILLA BANDA CR170
30	T24195085R	ASTA BANDELLE CR 190	PROTECTION FLAP BAR CR190	TIGE PALETTE PROTECTION CR190	DAS TURBAND STANGE CR190	VARILLA BANDA CR190
31	M71100532R	VITE M12X1,25X 25 SPEC.8.8 ZN	BOLT M12X1,25X25	VIS M12X1,25X25	SCHRAUBE M12X1,25X25	TORNILLO M12X1,25X25
32	F01410076R	ROS.M12 13X 24X2,5 U6592 ZN	WASHER 12 13X 24X2,5 U6592 ZN	RONDEL. M12 13X24X2,5 U6592 ZN	SCHRAUBE M12 13X24X2,5 U6592 ZN	ARANDELA M12 13X 24X2,5 U6592 ZN
33	T24155681R	PROTEZ. POSTERIORE PVC L=1530	REAR GUARD PVC L=1530			
34	T24155085R	ASTA BANDELLE CR 155	PROTECTION FLAP BAR CR155	TIGE PALETTE PROTECTION CR155	DAS TURBAND STANGE CR155	VARILLA BANDA CR155

**TAV.030**

- 23 - GIRAFFA L-SE 155
- 2 - GIRAFFA L-SE 170
- 3 - GIRAFFA L-SE 190

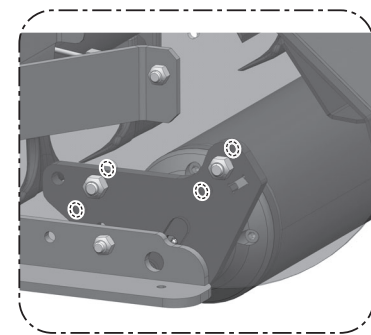
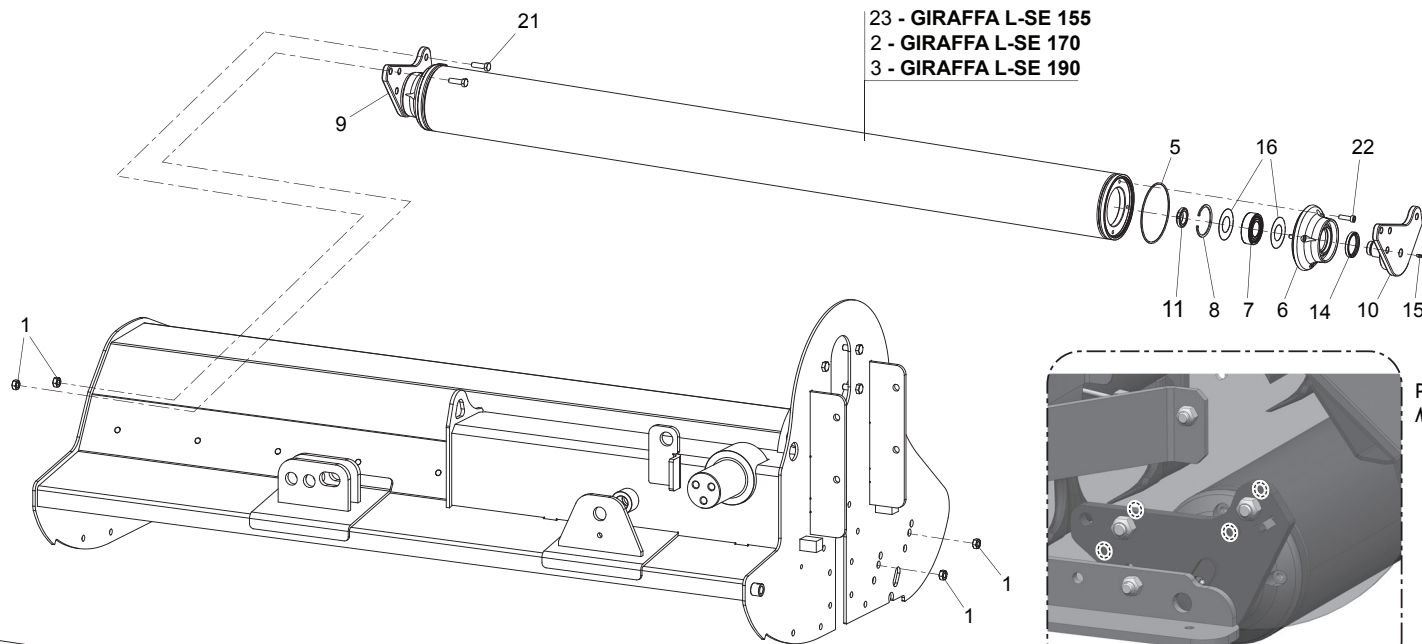

POSIZIONE INTERMEDIA  
MEDIUM POSITION

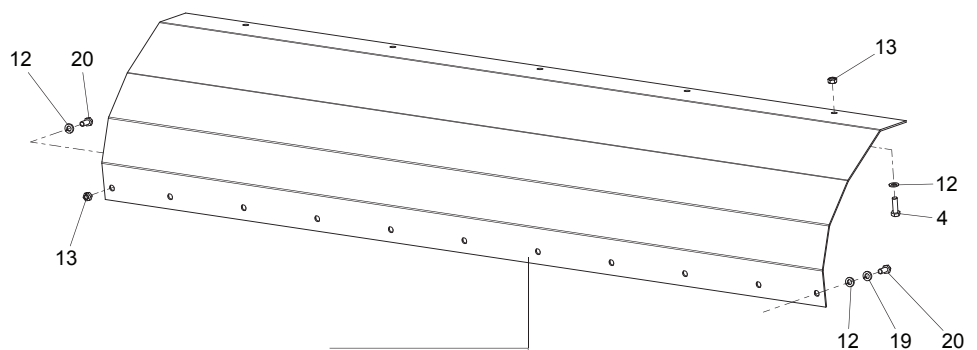

- 24 - GIRAFFA L 155
- 17 - GIRAFFA L 170
- 18 - GIRAFFA L 190

**OPTIONAL**  
LAMIERA ANTIUSURA  
DOUBLE SKIN

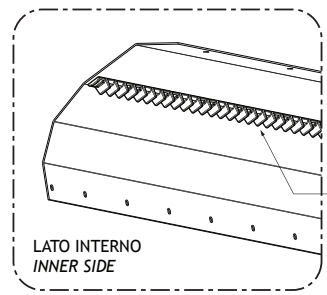

CONTROCOLTELLO SALDATO  
WELDED COUNTER-BLADE

LATO INTERNO  
INNER SIDE

**RULLO E LAMIERA ANTIUSURA  
REAR ROLLER AND DOUBLE SKIN FRAME**

**TAV.030**

Pos.	Cod.	Descrizione	Description	Description	Benennung	Description
1	F01220059R	DADO M14X1,5 D980 8ZN	NUT M14X1,5 D980 8ZN	ECROU M14X 1,5 D980 8 ZN	MUTTER M14X 1,5 D980 8 ZN	TUERCA M14X 1,5 D980 8 ZN
2	M30417602R	RULLO POST.D=168,3 L=1560	REAR ROLLER D=168,3 L=1560			
3	M30419602R	RULLO POST.D=168,3 L=1760 -	REAR ROLLER D=168,3 L=1760			
4	M71100532R	VITE M12X1,25X 25 SPEC.8.8 ZN	BOLT M12X1,25X25	VIS M12X1,25X25	SCHRAUBE M12X1,25X25	TORNILLO M12X1,25X25
5	F03010758R	ANEL. OR 148,82X3,53 NBR 70	GASKET OR 148,82X3,53 NBR 70	BAGUE OR 148,82X3,53 NBR 70	RING OR 148,82X3,53 NBR 70	ANILLO OR 148,82X3,53 NBR 70
6	M30400607R	SUPPORTO CUSCINETTO RULLO	ROLLER BEARING SUPPORT			
7	F04010327R	CUSC.D40 D80 B23 62208 2RS1	BEARING D40 D80 B23 62208 2RS1		BEARING D40 D80 B23 62208 2RS2	
8	F02050425R	ANELLO E. DI 80X 2,5 U7437 C70	SEEGER RING D.80	BAGUE SEEGER D.80	SEEGERRING D.80	ANILLO E. DI 80X 2,5 U7437 C70
9	M30400630R	STAFFA RULLO DX	RIGHT STIRRUP			
10	M30400631R	STAFFA RULLO SX	LEFT STIRRUP			
11	F02010022R	GHIERA AU.GUK M35X1,5 T.4H ZN	SELF LOCKING NUT M35X1,5	COLLIER AUTOBL. M35X1,5	SELBSTSP. NUTMUTTER M35X1,5	VIROLA AUTOBL. M35X1,5
12	F01410076R	ROS.M12 13X 24X2,5 U6592 ZN	WASHER 12 13X 24X2,5 U6592 ZN	RONDEL. M12 13X24X2,5 U6592 ZN	SCHEIBE M12 13X24X2,5 U6592 ZN	ARAND.M12 13X 24X2,5 U6592 ZN
13	F01220047R	DADO M12X1,25 D980 8ZN	NUT M12X1,25 D980 8ZN	ECROU M12X1,25 D980 8 ZN	MUTTER M12X1,25 D980 8 ZN	TUERCA M12X1,25 D980 8 ZN
14	F03010160R	ANELLO T.A. 50X 65X 8 D3760NBR	OIL SEAL 50X65X8	PARE-HUILE 50X65X8	OELABDICHTUNG 50X65X8	PARA-ACEITE 50X65X8
15	F01100011R	ING.M 6X1 7663-A 9SMNPB28 ZN	GREASE NIPPLE M6X1 7663-A ZN	GRAISS. A BILLE M6X1 7663A ZN	SCHMIERBUECHE M6X1 7663-A ZN	ENG.M 6X1 7663-A 9SMNPB28 ZN
16	M30400617R	ROSETTA SPESS. D=80 D=42 0,5	WASHER SPACER D=80 D=42 0,5			
17	M55717101R	LAMIERA ANTIUSURA	ANTI-WEAR SHEET			PLANCHA
18	M55719101R	LAMIERA ANTIUSURA	ANTI-WEAR SHEET			PLANCHA
19	F01480123R	ROS.G 12,5X22,9X 4 FLZNNC-240H	WASHER M12 ZGP EXTRA P.	RONDELLE M12 ZGP EXTRA P.	UNTERLEGSCHIEBE M12 ZGP EXTRA	ARANDELA M12 ZGP EXTRA P.
20	F01010283R	VITE M12X1,25X30 U5740 8.8ZN	SCR. M12X1,25X30 U5740 8.8ZN	VIS M 12X1,25X30	SCHRAUBE M 12X1,25X30	TORNILLO M 12X1,25X30
21	F01010318R	VITE M14X1,5X40 U5740 8.8ZN	SCR. M14X1,5X40 U5740 8.8ZN	VIS M 14X1,5X40	SCHRAUBE M 14X1,5X40	TORNILLO M 14X1,5X40
22	F01030285R	VITE M10X1,25X35 U5931 8.8DLS	SCREW M10X1,25X35 DLS			
23	M30415602R	RULLO POST.D=168,3 L=1410	REAR ROLLER D=168,3 L=1410			
24	M55715101R	LAMIERA ANTIUSURA	ANTI-WEAR SHEET			

**TAV.040**

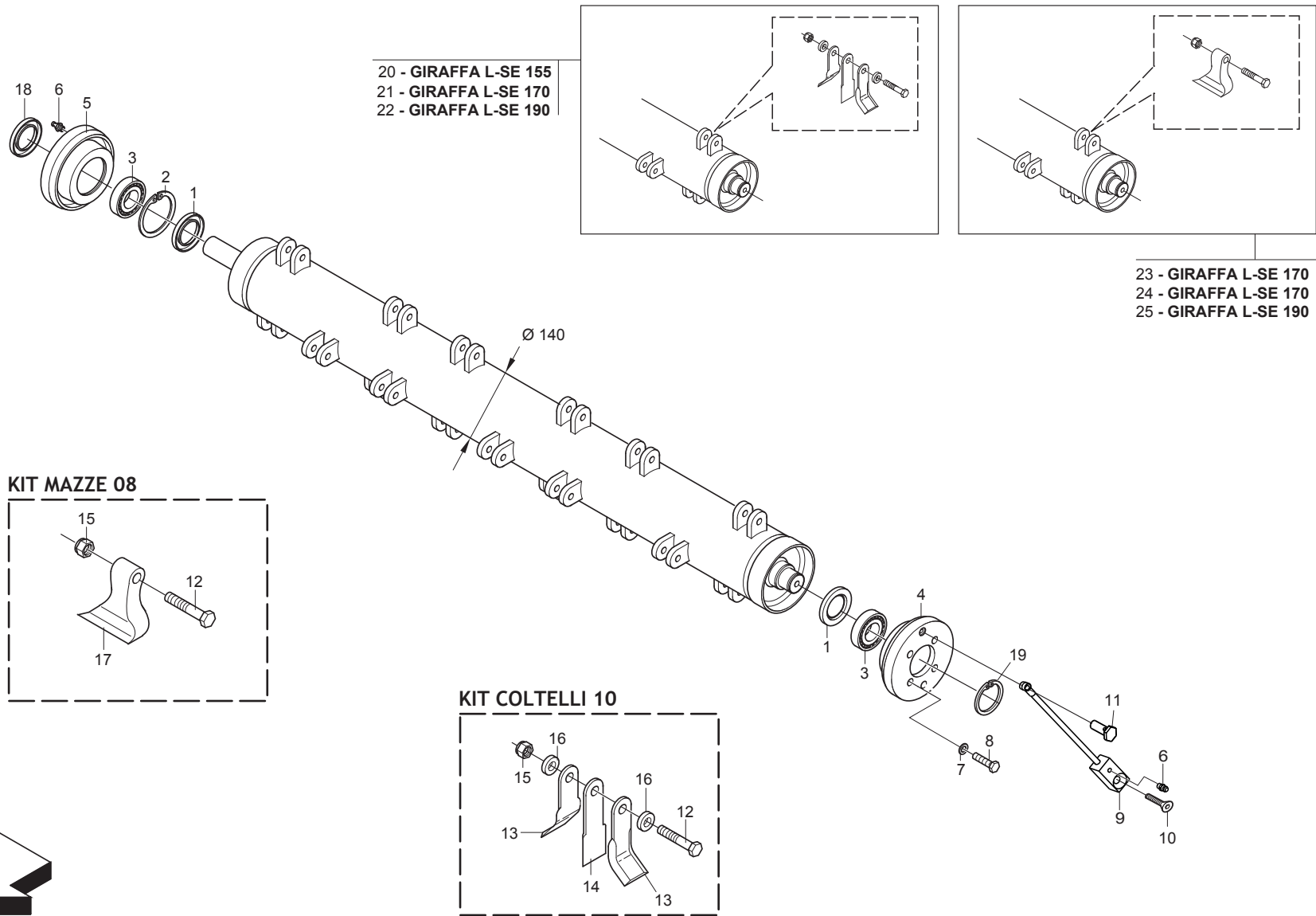

**ROTORE  
ROTOR**

**TAV.040**

Pos.	Cod.	Descrizione	Description	Description	Benennung	Description
1	F03010218R	ANELLO T.A. 65X100X10 D3760NBR	OIL SEAL 65X100X10	PARE-HUILE 65X100X10 D3760NBR	OELABDICHTUNG 65X100X10 D3760	ANILLO 65X100X10
2	F02050471R	ANELLO E. DI100X 3 U7437 C70	SEEGER RING D.100	BAGUE SEEGER D.100	SEEGERRING D.100	ANILLO SEEGER D.100
3	F04010031R	CUSC.D45 D100 B25 21309	BEARING D45 D100 B25 21309	ROULEMENT D45 D100 B25	LAGER D45 D100 B25	COJINETE D45 D100 B25
4	M25400410R	SUPPORTO ROTORE LATO TRASMISS.	ROTOR SUPPORT TRANSM. SIDE	SUPPORT ROTOR COTE TRANSM.	ROTORHALTER TRANSMISSIONSEITE	SOPORTE ROTOR LADO TRASMISSION
5	M25400409R	SUPPORTO ROTORE LATO ESTERNO	ROTOR SUPPORT SIDE PANEL	SUPPORT ROTOR PARTIE LATERALE	ROTORHALTER SEITENWAND	SOPORTE ROTOR FLANCO
6	F01100011R	ING.M 6X1 7663-A 9SMNPB28 ZN	GREASE NIPPLE M6X1 7663-A ZN	GRAISS. A BILLE M6X1 7663A ZN	SCHMIERBUECHE M6X1 7663-A ZN	ENG.M 6X1 7663-A 9SMNPB28 ZN
7	F01480123R	ROS.G 12,5X22,9X 4 FLZNNC-240H	WASHER M12 ZGP EXTRA P.	RONDELLE M12 ZGP EXTRA P.	UNTERLEGSCHIEBE M12 ZGP EXTRA	ARANDELA M12 ZGP EXTRA P.
8	F01010283R	VITE M12X1,25X30 U5740 8.8ZN	SCR. M12X1,25X30 U5740 8.8ZN	VIS M 12X1,25X30	SCHRAUBE M 12X1,25X30	TORNILLO M 12X1,25X30
9	T24004000R	ASSIEME INGRASSATORE	GREASE NIPPLE	GRAISSEUR	SCHMIERNIPPEL	ENGRASADOR
10	F01030058R	VITE M8X1,25X30 U5933 10.9ZD	SCR. M8X1,25X30 U5933 10.9ZD	VIS M8 X1,25 X30 U5933 10,9 ZD	SCHRAUBE M8X1,25X30 U5933 10,9	TORNILLO M8X1,25X30 U5933 10,9
11	T24004003R	VITE FORATA PER INGRASSAGGIO	BOLT	VIS	SCHRAUBE	TORNILLO
12	F20110093R	VIT. M16X1.5X95 SPEC. BR.10.9	BOLT M16X1.5X95 SPEC. BR.10.9	VIS M16X1.5X95 BR	SCHRAUBE M16X1.5X95 SPEC.	TORNILLO M16X1.5X95 SPEC.
13	T21004040R	COLTELLO A Y L=130	BLADE Y L=130	COUPEAU Y L=130	MESSER Y L=130	CUCHILLO A Y L=130
14	T21004050R	COLTELLO DIRITTO INT.L=130	STRAIGHT BLADE L=130	COUPEAU INT. L=130	INNEN MESSER L=130	CUCHILLO INT. L=130
15	F01230084R	DADO M16X1,5 D982 6ZN	NUT M16X1,5 D982 6ZN	ECROU AUTOBL.M16X1,5 ZN	SELBSTSPERR.MUTTER M16X1,5	DADO AUTOBL. M16X1,5
16	T21004045R	DISTANZIALE COLTELLI ZPG	BLADE SPACER	ENTRTOISE COTEAU	MESSER DISTANZSTUECK	DISTANCIADOR CUCHILLO
17	T24004025R	MAZZA 08	HAMMER 08	MARTEAUX 08 IMPR. 130	SCHLEGEL 08	MARTILLO 08
18	F03010139R	ANELLO T.A. 45X 80X10 D3760NBR	OIL SEAL 45X 80X10 D3760NBR	BOURRAGE 45X 80X10 D3760NBR	OELABDICHTUNG 45X 80X10 D3760	JUNTA DE ACEITE 45X 80X10
19	F02050191R	ANELLO E. DE 45X1,75 U7435 C70	RING 45X1,75 U7435 C70	BAGUE ELASTIQUE UNI 7435	EXT.RING DE 45X1,75 U7435 C70	ANILLO DE 45X1,75 U7435 C70
20	M25415412R	ROTORE COLT. 10	ROTOR WITH BLADES 10	ROTOR COUPEAUX 10	LAEUFER MESSER 10	ROTOR CUCHILLOS 10
21	M25417412R	ROTORE COLT. 10	ROTOR WITH BLADES 10	ROTOR COUPEAUX 10	LAEUFER MESSER 10	ROTOR CUCHILLOS 10
22	M25419412R	ROTORE COLT. 10	ROTOR WITH BLADES 10	ROTOR COUPEAUX 10	LAEUFER MESSER 10	ROTOR CUCHILLOS 10
23	M25415411R	ROTORE MAZZE 08	ROTOR HAMMER 08	ROTOR MARTEAUX 08	LAEUFER SCHLEGEL 08	ROTOR MARTILLOS 08
24	M25417411R	ROTORE MAZZE 08	ROTOR HAMMER 08	ROTOR MARTEAUX 08	LAEUFER SCHLEGEL 08	ROTOR MARTILLOS 08
25	M25419411R	ROTORE MAZZE 08	ROTOR HAMMER 08	ROTOR MARTEAUX 08	LAEUFER SCHLEGEL 08	ROTOR MARTILLOS 08

# TAV.050

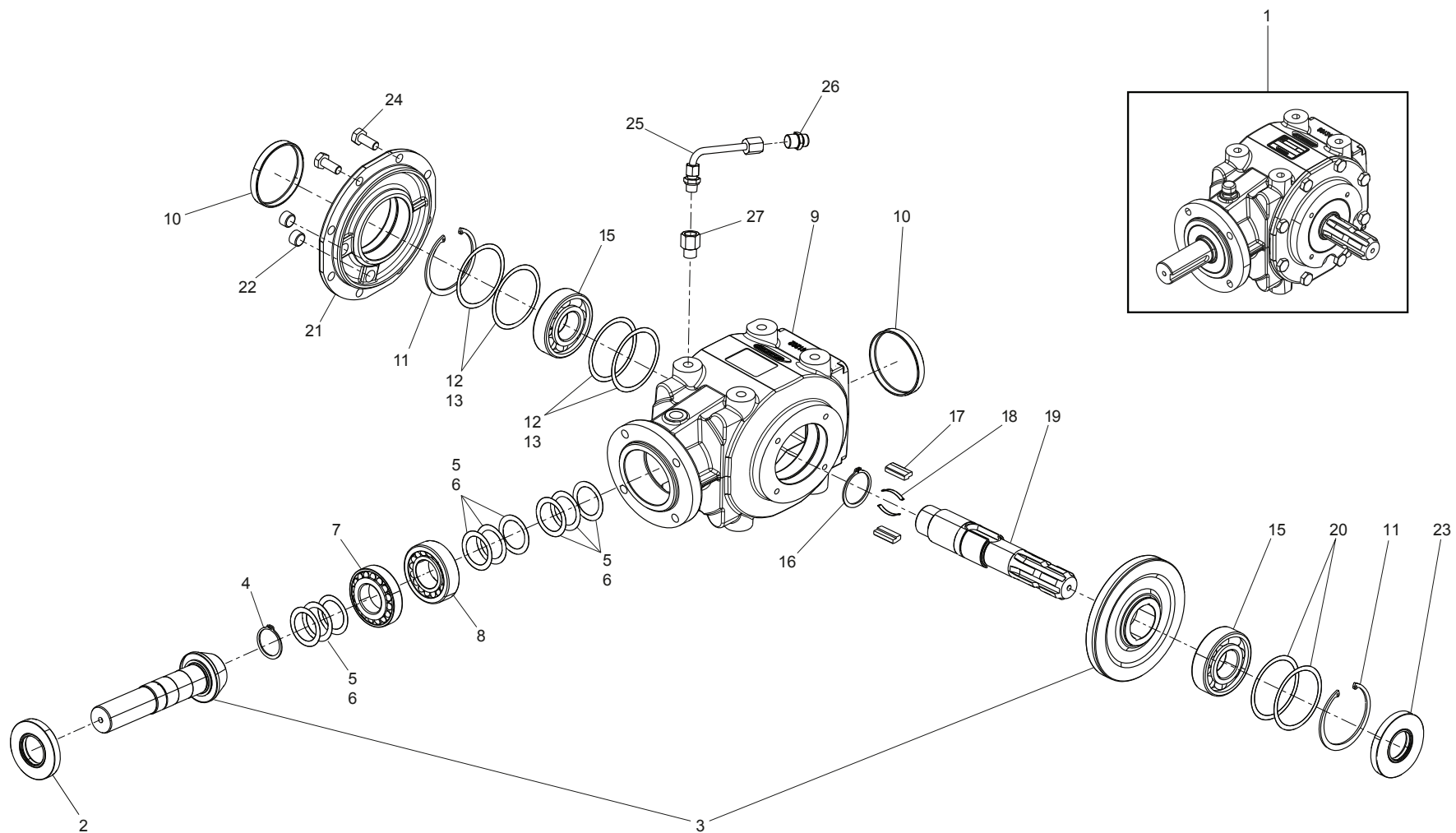

**MOLTIPLICATORE  
OVERDRIVE UNIT**

**TAV.050**

Pos.	Cod.	Descrizione	Description	Description	Benennung	Description
1	M30400201R	MOLTIPLICATORE 540 RPM	MULTIPLIER 540 RPM			
2	F03010088R	ANELLO T.AS.35X 72X10 D3760NB	OIL SEAL 35X72X10	PARA-HUILLE 35X72X10	OELABDICHTUNG 35X72X10	PARA-ACEITE 35X72X10
3	M30400203R	COPPIA CONICA 12 36 SCATOLA E.	BEVEL GEAR PAIR 12 36 S.E.			
4	F02050146R	ANELLO E. DE 35X 1,5 U7435 C70	ELASTIC RING DE 35X 1,5 U7435	BAGUE ELASTIQUE DE 35X 1,5	RING DE 35X 1,5 U7435 C70	ANILLO DE 35X 1,5 U7435 C70
5	T24001216R	ROSETTA D=48 D=35,5 L=0,5	WASHER D=48 D=35,5 L=0,5	ROSETTE D=48 D=35,5 L=0,5	SCHEIBE D=48 D=35,5 L=0,5	ARANDELLA D=48 D=35,5 L=0,5
6	T24001215R	ROSETTA D=48 D=35,5 L=0,25	WASHER D=48 D=35,5 L=0,25	ROSETTE D=48 D=35,5 L=0,25	SCHEIBE D=48 D=35,5 L=0,25	ARANDELLA D=48 D=35,5 L=0,25
7	F04050014R	CUSC.D35 D72 T18,25 30207	BEARING D35 D72 T18,25 30207	ROULEMENT 30207	LAGER 30207	COJINETE 30207
8	F04050070R	CUSC.D35 D72 T24,25 32207	BEARING D35 D72 T24,25 32207	ROULEMENT 32207	LAGER 32207	COJINETE 32207
9	T24001202R	CORPO RIDUTTORE	GEARBOX	BOITE DE VITESSE	WECHSELGETRIEBEGEHAUSE	CAJA CAMBIO
10	F03011026R	TAPPO CHIUSURA D=80 X 10 GA	COVER D. 80X10	BOUCHON 80X10	DECKEL 80X10	CORCHO 80X10
11	F02050425R	ANELLO E. DI 80X 2,5 U7437 C70	SEEGER RING D.80	BAGUE SEEGER D.80	SEEGERRING D.80	ANILLO E. DI 80X 2,5 U7437 C70
12	T24001214R	ROSETTA D=79,6 D=69,4 L=0,25	WASHER D=79,6 D=69,4 L=0,25	ROSETTE D=79,6 D=69,4 L=0,25	SCHEIBE D=79,6 D=69,4 L=0,25	ARANDELLA D=79,6 D=69,4 L=0,25
13	T24001213R	ROSETTA D=79,6 D=69,4 L=0,15	WASHER D=79,6 D=69,4 L=0,15	ROSETTE D=79,6 D=69,4 L=0,15	SCHEIBE D=79,6 D=69,4 L=0,15	ARANDELLA D=79,6 D=69,4 L=0,15
15	F04010216R	CUSC.D35 D80 B21 6307	BEARING D35 D80 B21 6307	ROULEMENT 6307	LAGER 6307	COJINETE 6207
16	F02050179R	ANELLO E. DE 42X1,75 U7435	COMPRESSION RING D.42	ANNEAU RESSORT D.42	RING D.42	ANILLO D.42
17	T24001204R	LINGUETTA DI INNESTO	KEY	CLAVETTE	KEIL	LLAVE
18	T24001203R	MOLLA	SPRING	RESSORT	FEDER	MUELLE
19	M30400202R	ALBERO X COR.D=42 L=232,5 SC.E	SHAFT D=42 L=232,5			
20	M07400223R	ROSETTA D=52 D=35,4 S=2,5	WASHER D=52 D=35,4 S=2,5	ROSETTE D=52 D=35,4 S=2,5	SCHEIBE D=52 D=35,4 S=2,5	ARANDELLA D=52 D=35,4 S=2,5
21	T24001208R	FLANGIA CORPO TRASMISSIONE	GEARBOX COVER	COUVERCLE BOITE A VITESSES	GETRIEBEDECKEL	TAPA CAJA CAMBIO
22	F03150719R	TAPPO 3 8 GAS	GAS CAP 3 8	BOUCHON	DECKEL	CORCHO
23	F03010265R	ANELLO T.AS 35X 80X10 D3760NBR	RING T.AS 35X80X10 D3760 NBR	BAGUE T.AS 35X 80X10 D3760 NBR	SCHUTZRING 35X80X10 D3760 NBR	INEL T.AS 35X80X10 D3760 NBR
24	F01010244R	VITE M10X1,25X25 U5740 8.8ZN	SCR. M10X1,25X25 U5740 8.8ZN	VIS M 10X1,25X25	SCHRAUBE M 10X1,25X25	TORNILLO M 10X1,25X25
25	M07400216R	PROLUNGA SFIATO 90	BREATHER PLUG 90	BOUCHON DE SOUPIRAIL 90	ENTLUEFTERSTOPFEN 90	TAPON RESPIRADERO 90
26	F03150718R	TAPPO 3 8 GAS CON SFIATO	GAS BREATHEN PLUG 3 8	BOUCHON D HUILE SOUPIRAIL	OELENTLUEFTERSTOPFEN	TAPON ACEITE
27	F03020113R	PROLUNGA M F 3 8 L22 L.TOT=33	EXTENSION M F 3 8 L22 L.TOT=33			

**TAV.060**

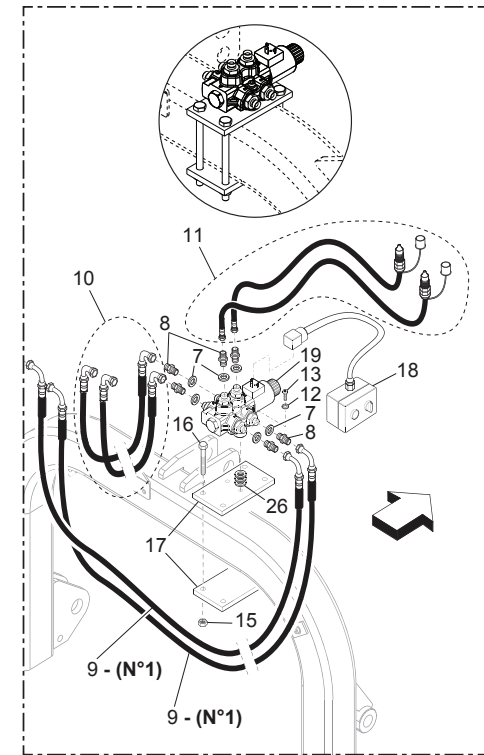
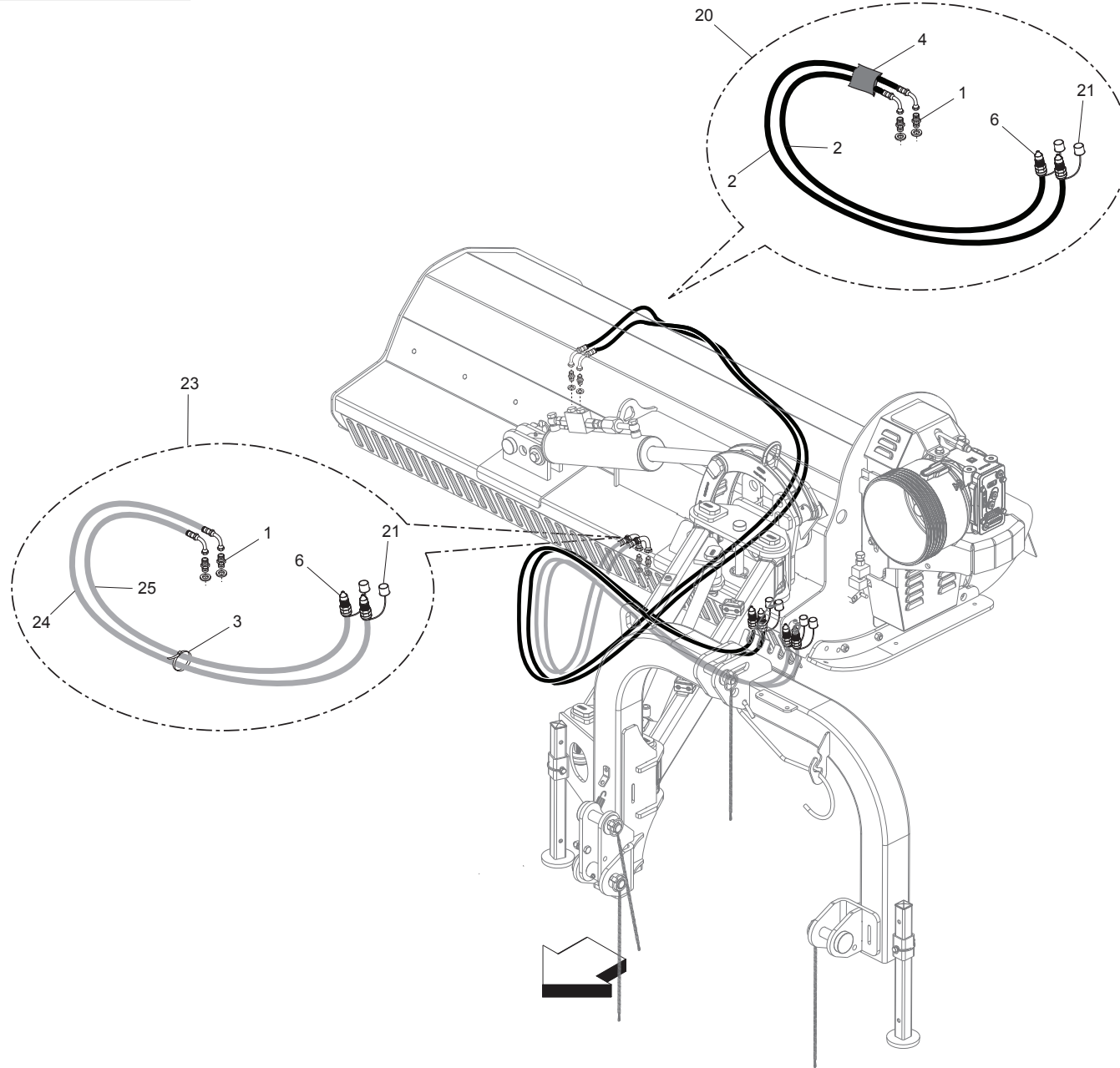

**OPTIONAL**  
 KIT RIDUZIONE TUBI IDRAULICI  
 HYDRAULIC TUBE REDUCTION KIT



**IMPIANTO IDRAULICO  
HYDRAULIC PLANT**

**TAV.060**

Pos.	Cod.	Descrizione	Description	Description	Benennung	Description
1	F03080081R	NIPPLO M3 8 SEAL ML10 ZN	NIPPLE M3 8 SEAL ML10 ZN			
2	F03070313R	TG 1 4 R17 FL10 CFL10 4300	RUB.TUBE R17 FL10 CFL10 4300			
3	F05150067R	FASCETTA NERA 9X350	BLACK BAND	BANDE NOIR 9X350	SCHWARZE BAND 9X350	CINTA
4	F03100365R	GUAINA TELATA D=65 L=4000	SHEATH D=65 L=4000	GAINÉ D=65 L=4000	MANTEL D=65 L=4000	VAINA D=65 L=4000
6	F03080090R	INNESTO RAP.MASCH.DL M16X1,5	QUICK CONNECT MALE CONE DL M16			
7	F03020070R	RONDELLA BONDED AUTOCENT 3 8	AUTOCENT BONDED WASHER 3 8	RONDELLE BONDED AUTOCENT 3 8	SCHEIBE BONDED AUTOCENT 3 8	ARANDELA BONDED AUTOCENT 3 8
8	F03150310R	NIPPLO MM CIL-CIL 3 8-1 4 ZN	NIPPLE CYL.MALE3 8-1 4 ZN	NIPPLE MALE CYL.3 8-1 4 ZN	NIPPELZYL.3 8-1 4 ZN	NIPLE MACHO CIL.3 8-1 4 ZN
9	F03050235R	TUBO 2SN 1 4 FD1 4 F901 4 3500	HYDRAULIC TUBE R2AT 1 4	TUBE HYDRAUL. R2AT 1 4 L 3400	HYDRAUL. ROHR R2AT 1 4 L 3400	TUBO HYDRAULICO R2AT 1 4
10	F03060013R	KIT TUBAZ.IDR.X KIT GF	HYDRAULIC PIPE KIT GF			
11	M58100890R	PREMONT.TUB.IDR.MART.LAT. GUA	HYDRAULIC TUBE	TUBE HYDRAUL.	HYDRAUL. ROHR	TUBO HYDRAULICO
12	F01480088R	ROS.G 6,4X12,4X2 FLZNNC-240H	GROWER WASHER D.6	RONDELLE GROWER D.6	SCHEIBE GROWER D.6	ARANDELA GROWER D.6
13	F01040068R	VITE M6X1X50 U5931 8.8ZN	SCR. M6X1X50 U5931 8.8ZN	VIS M 6X1X50	SCHRAUBE M 6X1X50	TORNILLO M 6X1X50
15	F01220034R	DADO M10X1,25 D980 8ZN	NUT M10X1,25 D980 8ZN	ECRO.M10X1,25 D980 8 ZB	MUTT.M10X1,25 D980 8 ZB	TUER.M10X1,25 D980 8 ZB
16	F01010038R	VITE M10X1,25X140 U5738 8.8ZN	SCR. M10X1,25X140 U5738 8.8ZN	VIS M10X1,25X140 5738 8.8 ZN	SCHAR.M10X1,25X140 5738 8.8 ZN	TORN. M10X1,25X140 5738 8.8 ZN
17	M07400805R	STAFFA PORTA DEVIATORE	SUPPORT SHUNTER STIRRUP			
18	M58100872R	COMANDO ELETTRICO 12V DC	ELECTRIC CONTROL	COMMANDE ELECTRIQUE	ELEKTRISCHER ANTRIEB	ACCIONAMENTO ELECTRICO
19	F03151042R	DEVIATORE A 6 VIE 2 POSIZIONI	DISTRIBUTOR	DISTRIBUTEUR	VERTEILER	DISTRIBUIDOR
20	F03060228R	KIT TUBAZ.IDR.GF L=4300 DIN24	KIT PIPES HYDR L=4300 DIN24			
21	F05150325R	CAPPUC.F X INN.M RAP.1 2 ROSS	COVER CONNECT F 1 2 RED	COUVERCLE CONNEXION F 1 2 ROSE	DECKEL W 1 2 SCHNELLKUPP. ROT	PAC PROTECCION F 1 2 ROJO
23	F03060226R	KIT TUBAZ.IDR.GF L=2500 DIN24	KIT PIPES HYDR L=2500 DIN24			
24	F03070231R	TG 1 4 R17 FL10 CFL10 2500	TG 1 4 R17 FL10 CFL10.2500			
25	F03070090R	TUBO 1 4 R17 FL10 CFL10 L2200	PIPE 1 4 R17 FL10 CFL10 L2200			
26	F01420036R	ROS.M6 6,4X 18X1,5 U6593 ZN	WASHER M6 6,4X 18X1,5 U6593 ZN	RONDELLE M6 6,4X18X1,5 U6593ZN	SCHEIBEN M6 6,4X18X1,5U6593 ZN	ARANDELA M6 6,4X18X1,5U6593ZN

**TAV.070**

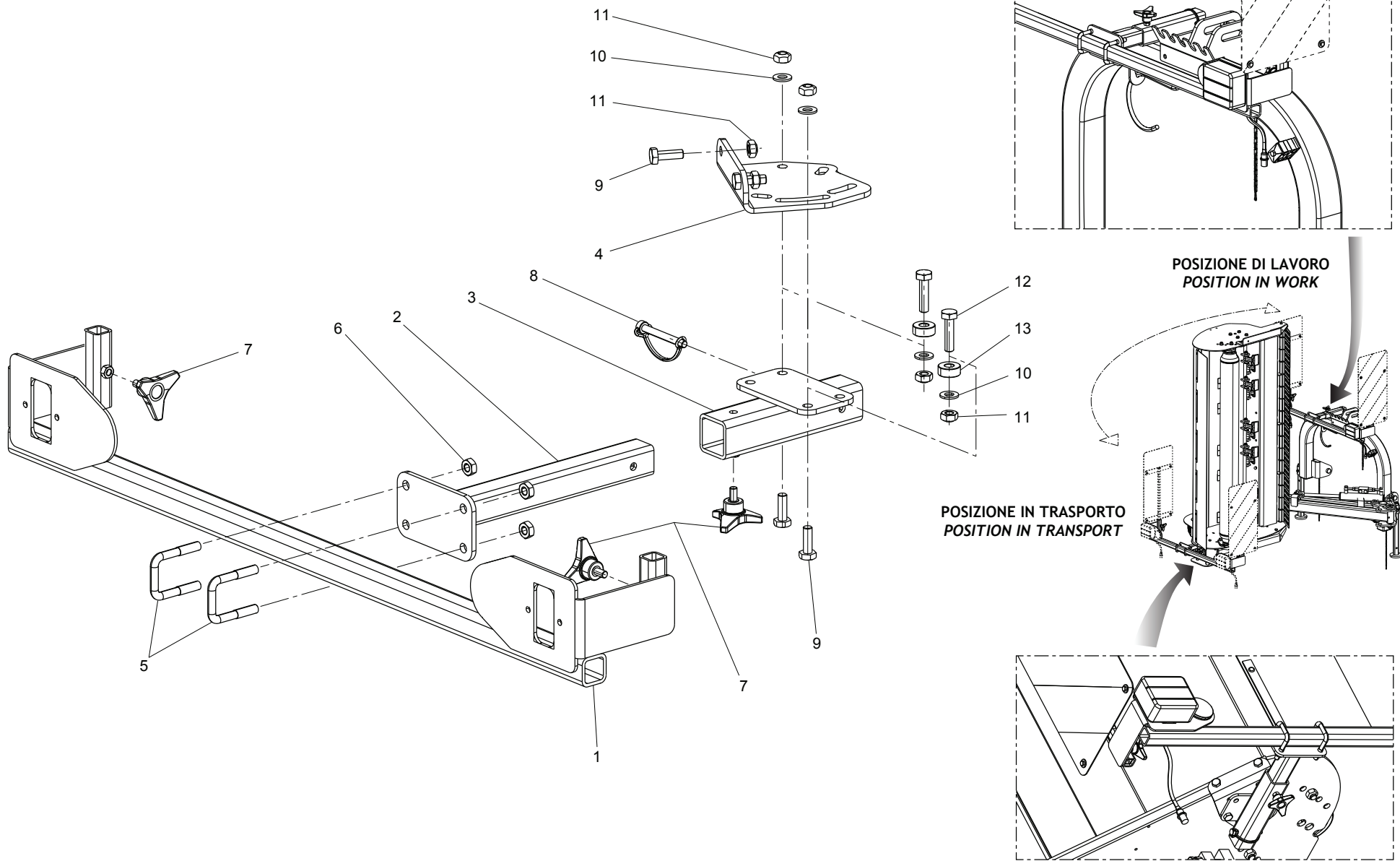

**SUPPORTI TABELLE STRADALI  
ROAD KIT SUPPORTS**

**TAV.070**

Pos.	Cod.	Descrizione	Description	Description	Benennung	Description
1	M50400758R	SUPPORTO SEGN.STRAD.BARRA LUCI	ROAD SIGN.SUPPORT			
2	M50400761R	STAFFAGGIO	BRACKET			
3	M50400764R	STAFFAGGIO	BRACKET			
4	M50400767R	STAFFA	CLAMP			
5	F20110706R	CAV.Q.B=35 M=10X1,5 L=60	U BOLT Q.B=35 M=10X1,5 L=60	CAVALIER SUPPORT DISQUE SV	VERBINDUNG SCHEIBENHALTERUNG S	PERNO EN U SOP. DISCO SV
6	F01220033R	DADO M10X1,5 D980 8ZN	NUT M10X1,5 D980 8ZN	ECROU M10X1,5 D980 8ZN	MUTTER M10X1,5 D980 8ZN	TUERCA M10X1,5 D980 8
7	F06220018R	VOLANTINO 3LOBI D.65-M8X15	3-LOBE HANDWHEEL D.65-M8X15			
8	F02200562R	SPINA SICUR.D. 8X70 ZN	SNAP PIN D.8X 70 ZN	FICHE EL. D.8X70 ZN	SCHERSTIFT D.8X 70 ZN	CLAVIJA D.8X 70 ZN
9	F01010250R	VITE M10X1,25X30 U5740 8.8ZN	SCR. M10X1,25X30 U5740 8.8ZN	VIS M10X1,25X30 U5740 8.8 ZB	SCHR.M10X1,25X30 U5740 8.8 ZB	TORN.M10X1,25X30 U5740 8.8 ZB
10	F01410064R	ROS.M10 10,5X 20X 2 U6592 ZN	WASHER M10 10,5X20X2 U6592 ZN	RONDEL. M10 10,5X20X2 U6592 ZN	SCHEIBE M10 10,5X20X2 U6592 ZN	ARAND.M10 10,5X 20X 2 U6592 ZN
11	F01220034R	DADO M10X1,25 D980 8ZN	NUT M10X1,25 D980 8ZN	ECRO.M10X1,25 D980 8 ZB	MUTT.M10X1,25 D980 8 ZB	TUER.M10X1,25 D980 8 ZB
12	F01010039R	VITE M10X1,25X40 U5740 10.9ZD	SCR. M10X1,25X40 U5740 10.9ZD	VIS M 10X1,25X40 U5740 10.9ZD	SCHRA.M10X1,25X40 U5740 10.9ZD	TORN. M10X1,25X40 U5740 10.9ZD
13	M33100599R	DISTANZIALE PROTEZIONE ERP.ZPG	SPACER	ENTRETOISE	DISTANZSTUECK	DISTANCIADOR

# TAV.080

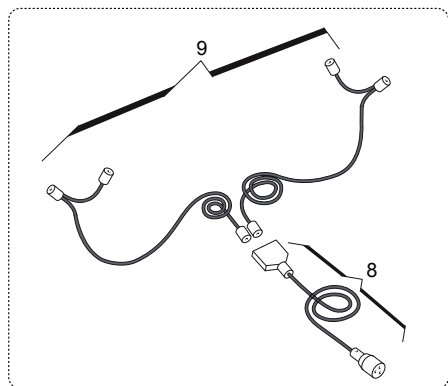
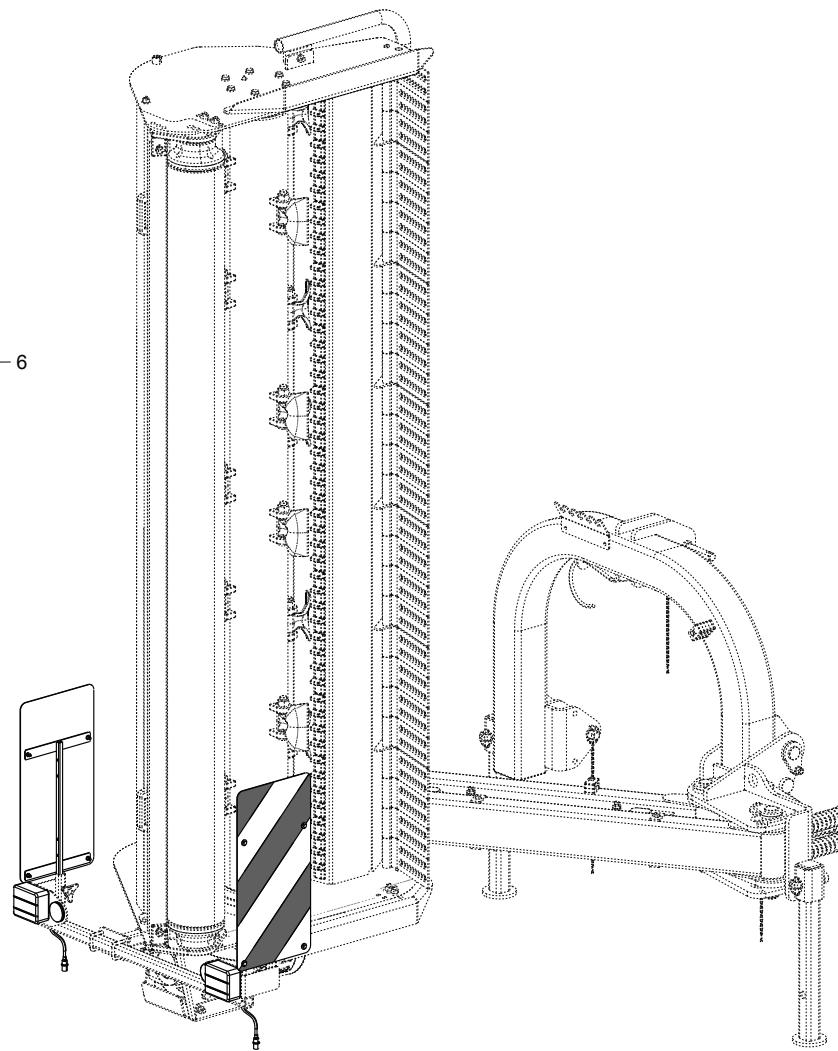
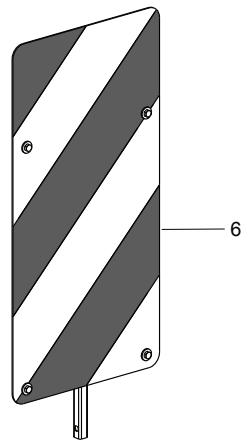
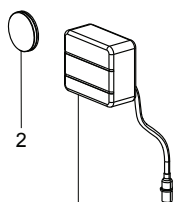
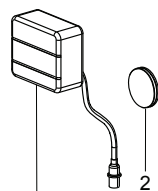
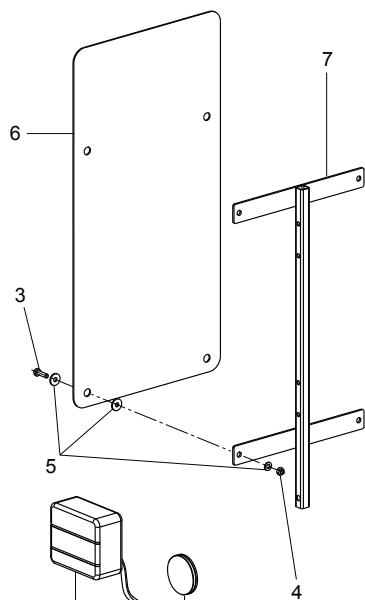

**KIT TABELLE STRADALI G99600020  
ROAD TRANSPORT KIT G99600020**

**TAV.080**

Pos.	Cod.	Descrizione	Description	Description	Benennung	Descripcion
1	F05010822R	KIT FANALI DX-SX CON CAVO	KIT REAR ROAD LIGHTS MOUNTED			
2	F05010820R	CATARIFR.TONDO D60 ROSSO	ROUND REFLECTOR D.60 RED			
3	F01020404R	VITE M6X1X20 U5739 8.8ZN	SCREW M6X1X20 U5739 8.8ZN	VIS M6X1X20 U5739 8.8ZN	SCHRAUBE M6X1X20 U5739 8.8ZN	TORNILLO M6X1X20 U5739 8.8ZN
4	F01220011R	DADO M6X1 D980 8ZN	NUT M6X1 D980 8ZN	ECROU M6X1 D980 8 ZN	MUTTER M6X1 D980 8 ZN	TUERCA M6X1 D980 8 ZN
5	F01420036R	ROS.M6 6,4X 18X1,5 U6593 ZN	WASHER M6 6,4X 18X1,5 U6593 ZN	RONDELLE M6 6,4X18X1,5 U6593ZN	SCHEIBEN M6 6,4X18X1,5U6593 ZN	ARANDELA M6 6,4X18X1,5U6593ZN
6	F05010816R	TABELLE 2 CAR.SPORGENTI IT	WARNING BOARDS 2 IT			
7	G16612071R	TELAIO SUPP.TABELLE STRAD.	FRAME SUPPORT TABLE			
8	F05200026R	CABLAGGIO PRINCIPALE	MAIN CABLE			
9	F05010822R	KIT FANALI DX-SX CON CAVO	KIT REAR ROAD LIGHTS MOUNTED			

**TAV.090**

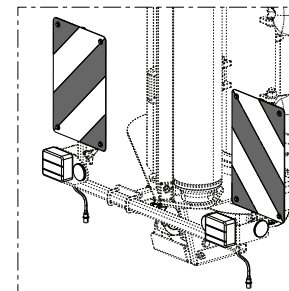
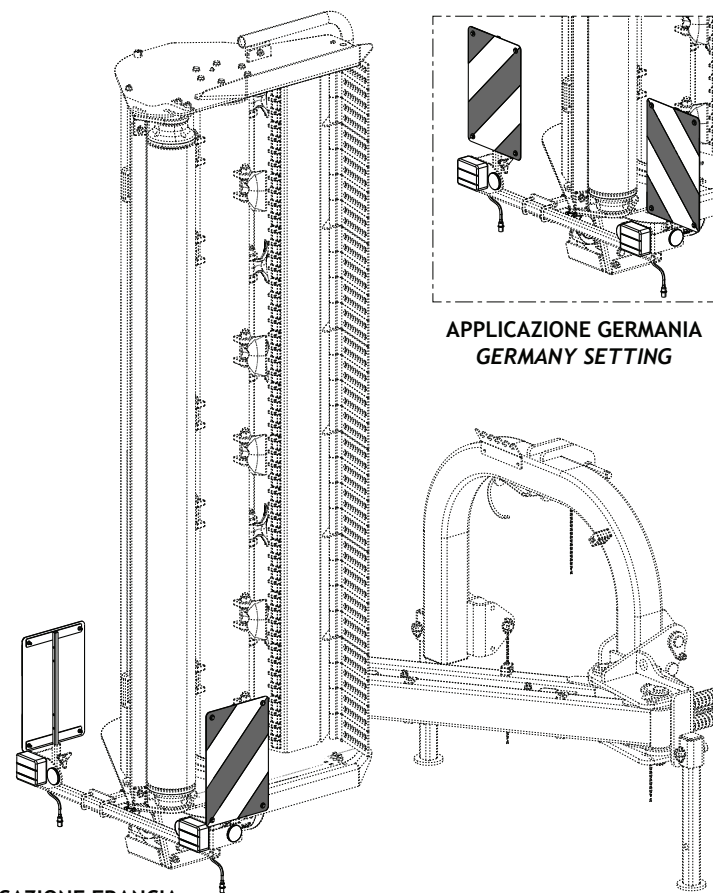
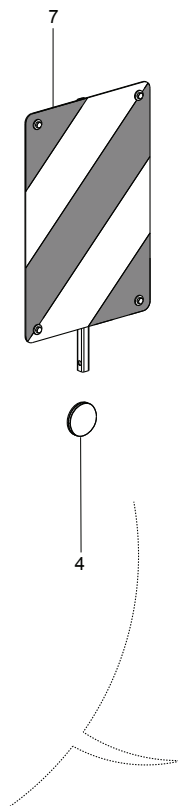
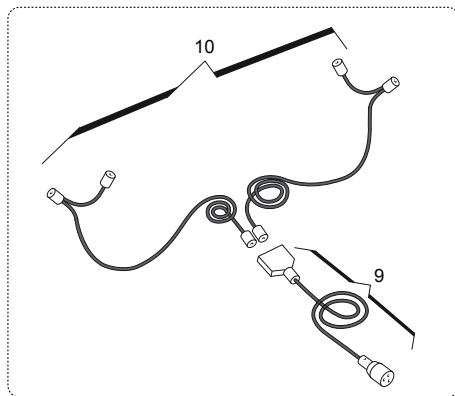
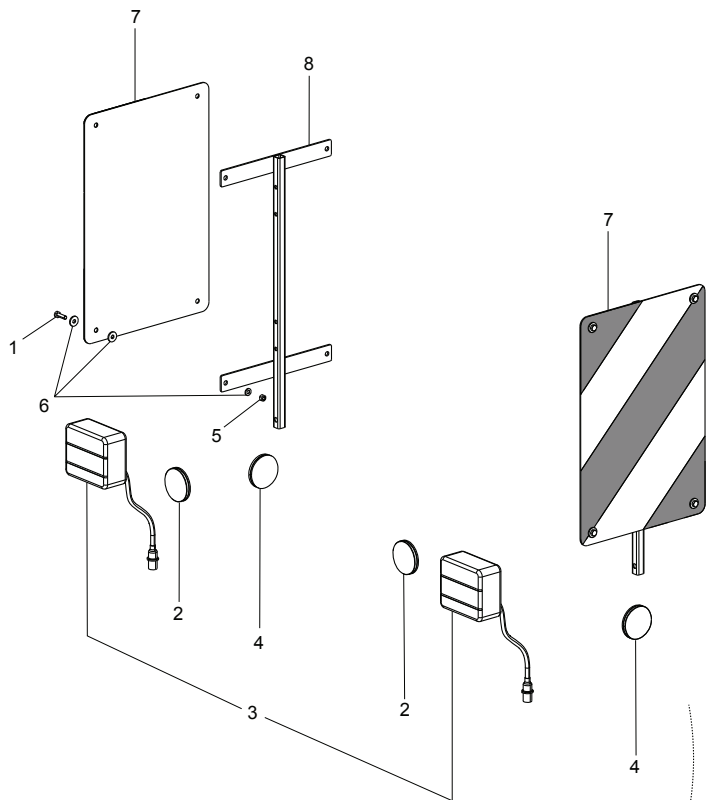

**APPLICAZIONE GERMANIA  
GERMANY SETTING**





**APPLICAZIONE FRANCIA  
FRANCE SETTING**

**KIT TABELLE STRADALI G99600021  
ROAD TRANSPORT KIT G99600021**

**TAV.090**

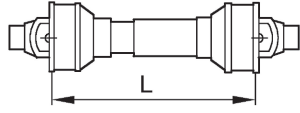
Pos.	Cod.	Descrizione	Description	Description	Benennung	Descripcion
1	F01020404R	VITE M6X1X20 U5739 8.8ZN	SCREW M6X1X20 U5739 8.8ZN	VIS M6X1X20 U5739 8.8ZN	SCHRAUBE M6X1X20 U5739 8.8ZN	TORNILLO M6X1X20 U5739 8.8ZN
2	F05010820R	CATARIFR.TONDO D60 ROSSO	ROUND REFLECTOR D.60 RED			
3	F05010822R	KIT FANALI DX-SX CON CAVO	KIT REAR ROAD LIGHTS MOUNTED			
4	F05010819R	CATARIFR.TONDO D60 GIALLO	ROUND REFLECTOR D.60 YELLOW	JAUNE R FLECTEUR ROUND	RUNDREFLEKTOR GELB D60	REFLECTOR REDONDO AMARILLO
5	F01220011R	DADO M6X1 D980 8ZN	NUT M6X1 D980 8ZN	ECROU M6X1 D980 8 ZN	MUTTER M6X1 D980 8 ZN	TUERCA M6X1 D980 8 ZN
6	F01420036R	ROS.M6 6,4X 18X1,5 U6593 ZN	WASHER M6 6,4X 18X1,5 U6593 ZN	RONDELLE M6 6,4X18X1,5 U6593ZN	SCHEIBEN M6 6,4X18X1,5U6593 ZN	ARANDELA M6 6,4X18X1,5U6593ZN
7	F05010817R	TABELLE 2 CAR.SPORGENTI FR-D	WARNING BOARDS 2 FR-DE	TABLEAUX 2 AVERTISSEM. FR-DE	BRETT 2 WARNUNG FR-DE	TABLAS 2 CAR.ADVERT. FR-DE
8	G16612071R	TELAIO SUPP.TABELLE STRAD.	FRAME SUPPORT TABLE			
9	F05200026R	CABLAGGIO PRINCIPALE	MAIN CABLE			
10	F05010822R	KIT FANALI DX-SX CON CAVO	KIT REAR ROAD LIGHTS MOUNTED			

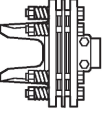
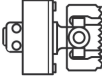
**COMER**

				
7 - F08012317 L=1810 1 3/8" Z6	--	--	--	--

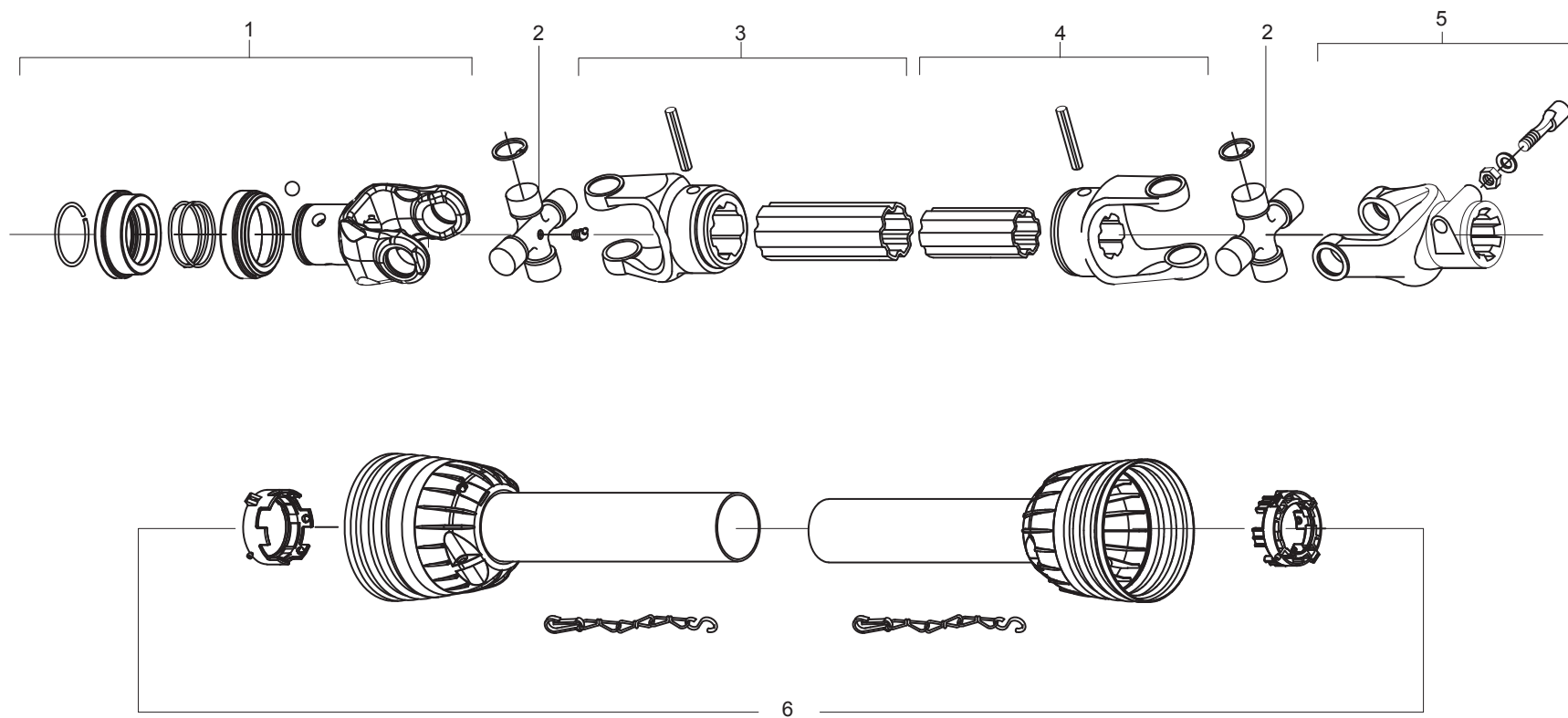



**CARDANO F08012317**  
**F08012317 CARDAN SHAFT**





**TAV.100**

Pos.	Cod.	Descrizione	Description	Description	Benennung	Descripcion
1	F08013108R	FORCELLA 13 8 Z6	COMPLETE COLLAR YOKE C12 13 8			
2	F08013112R	CROCIERA COMPLETA	SPIDER ASSY			
3	F08013110R	FORCELLA SPINA TUB ESTERN	FORK SPUR EXTERNAL TUBE			
4	F08013111R	FORCELLA SPINA TUB INTERN	151.016.389.1 FORK. SP T.INT			
5	F08013109R	FORCELLA 152 1 3 8 Z6	COMPLETE TAPERED PIN YOKE			
6	F08013113R	PROTEZIONE COMPLETA	COMPLETE PROTECTION			
7	F08012317R	CAR 40 CO 38Z6 DIR L2049	CAR 40 CO 38Z6 DIR L2049			

**TAV.110**

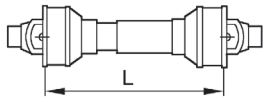
**OPTIONAL**

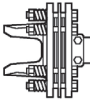
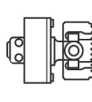
**WALTERSCHEID**

				
6 - F08011608 L=1934 1 3/8" Z6	--	--	--	--

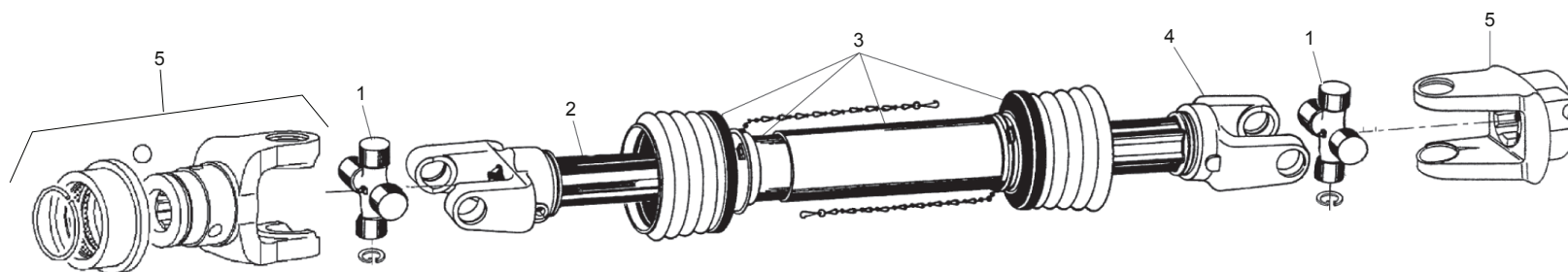





**CARDANO F08011608**  
**F08011608 CARDAN SHAFT**

**TAV.110**

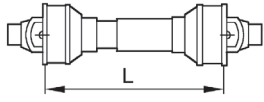
Pos.	Cod.	Descrizione	Description	Description	Benennung	Description
1	F08010683R	CROCIERA COMPLETA W2300	SPIDER ASSY	CROISIERE COMPL.	GELENKKREUZ KOMPL.	CRUCETA COMPL.
2	F08010720R	FORC.COMP.TUBO INT.W2400 L1380	FORK WITH INTERNAL PIPE	FOURCHE AVEC TUBE INT.	GABELST. AUSSENROHR	HORQUILLA TUBO INT.
3	F08010896R	PROTEZIONE COMPL.WS GIRAFFA	PROTECTION ASSY	PROTECTION COMPL.	KOMPL. SCHUTZ	PROTECCION COMPL.
4	F08010729R	FORC.COMP.TUBO EST.W2400 L1565	FORK WITH EXTERNAL PIPE	FOURCHE AVEC TUBE EXTERIEUR	GABELST. AUSSENROHR	HORQUILLA TUBO EXTERNO
5	F08010457R	FORCELLA COMPLETA DI PULSANTE	LINKAGE FORK	FOURCHE ATTELAGE	GABELSTUECK	HORQUILLA ATAQUE
6	F08011608R	CARD.GKN	UNIVERSAL P T O SHAFT	ARBRE A CARDAN	GELENKWELLE	ARBOL CARDANICO

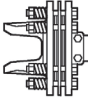
**WALTERSCHEID**

				
7 - F08011565 L=1934	--	--	--	--

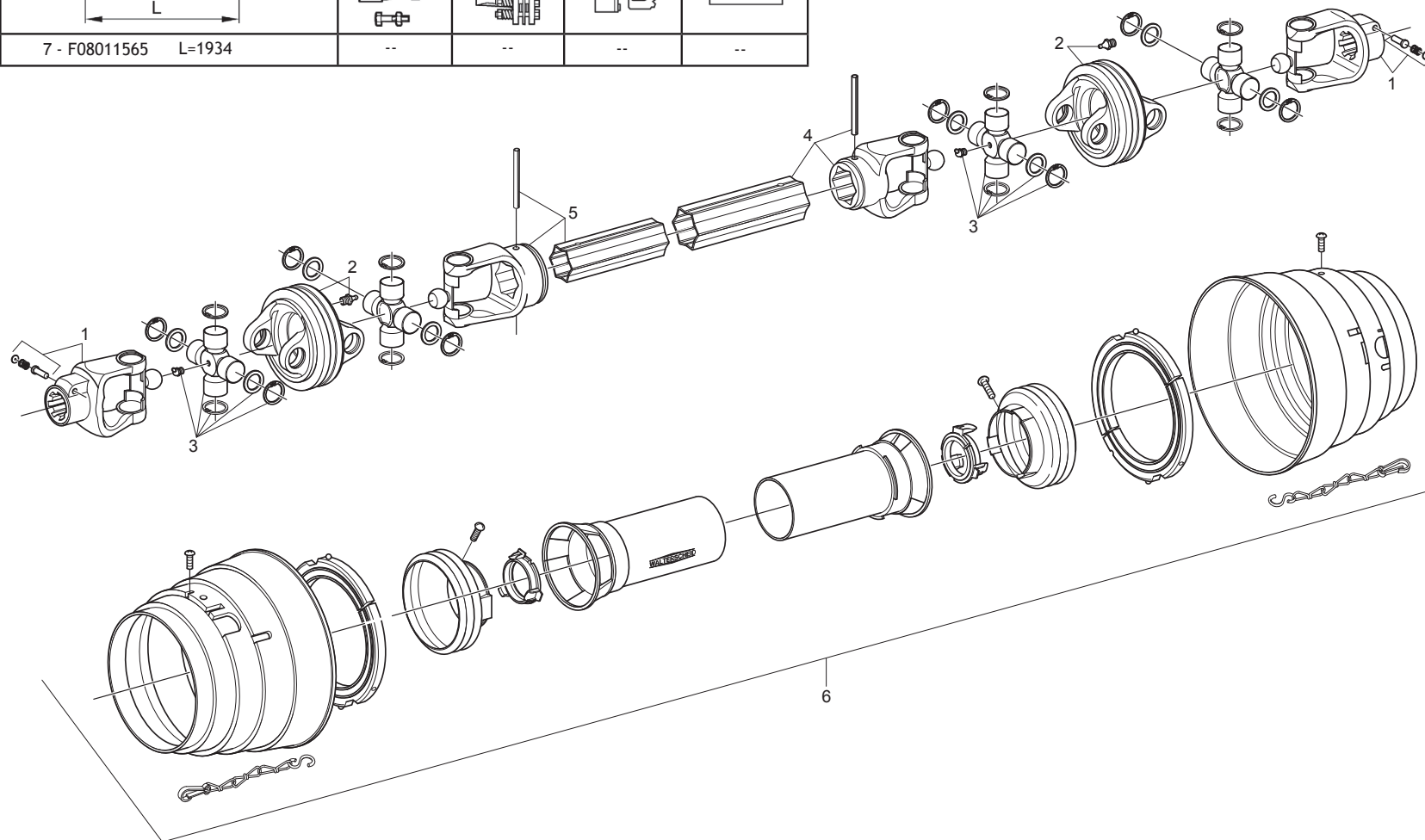

**CARDANO OMOCINETICO WALTERSCHEID  
WALTERSCHEID CONSTANT VELOCITY PTO SHAFT**

**TAV.120**

Pos.	Cod.	Descrizione	Description	Description	Benennung	Description
1	F08010463R	FORCELLA COMPLETA DI PULSANTE	LINKAGE FORK PUSHBUTTON	FOURCHE ATTELAGE POUSSOIR	GABELSTUECK DRUCKKNOPF	HORQUILLA ATAQUE PULSADOR
2	F08010223R	FORCELLA DOPPIA INGRASSATORE	DOUBLEYOKE GREASENIPPLE	MACHOIRE DOUBLE GRAISSEUR	DOPPELGABEL SCHMIERNIPPEL	HORQUILLA DOBLA ENGRASADOR
3	F08010687R	CROCIERA COMPLETA	SPIDER ASSY	CROISIERE COMPL.	GELENKKREUZ KOMPL.	CRUCETA COMPLETA
4	F08010662R	FORCELLA TUBO ESTERNO SPINA	FORK WITH EXTERNAL PIPE	FOURCHE AVEC TUBE EXTERIEUR	GABELST. AUSSENROHR	HORQUILLA TUBO EXTERNO
5	F08010661R	FORCELLA TUBO INTERNO SPINA	FORK WITH INTERNAL PIPE	FOURCHE AVEC TUBE INT.	GABELST. INNENROHR	HORQUILLA TUBO INT.
6	F08010897R	PROTEZIONE COMPLETA CARDANO	PROTECTION ASSY	PROTECTION COMPL.	KOMPL. SCHUTZ	PROTECCION COMPL.
7	F08011565R	CARD.GKN 2480-1710-SD25-S4LH S	SHAFT GKN*2480-1710-SD25-S4LH			

**USATE SEMPRE RICAMBI ORIGINALI  
ALWAYS USE ORIGINAL SPARE PARTS  
IMMER DIE ORIGINAL-ERSATZTEILE VERWENDEN  
EMPLOYEZ TOUJOURS LES PIECES DE RECHANGE ORIGINALES  
UTILIZAR SIEMPRE REPUESTOS ORIGINALES**



**Servizio Assistenza Tecnica - After Sales Service  
Servizio Ricambi - Spare Parts Service**



**maschio.com**

DEALER:



**MASCHIO GASPARDO SpA**

**Registered Office and Production Plant**

Via Marcello, 73 - 35011 Campodarsego (Padova) - Italy

Tel. +39 049 9289810

Fax +39 049 9289900

info@maschio.com

www.maschionet.com

**MASCHIO DEUTSCHLAND GMBH**

Äußere Nürnberger Straße 5

D - 91177 Thalmässing - Deutschland

Tel. +49 (0) 9173 79000

Fax +49 (0) 9173 790079

dialog@maschio.de

www.maschionet.de

**MASCHIO FRANCE Sarl**

1 rue Denis Papin ZA

F - 45240 La Ferte St. Aubin

France

Tel. +33 (0) 2.38.64.12.12

Fax +33 (0) 2.38.64.66.79

info@maschio.fr

**000 МАСКИО-ГАСПАРДО РУССИЯ**

04130, Россия,

Волгоградская область,

г. Волжский, ул. Пушкина, 117 «б».

Тел.: +7 8443 203100

факс: +7 8443 203101

e-mail: info@maschio.ru

**MASCHIO GASPARDO SpA**

**Production Plant**

Via Mussons, 7 - 33075 Morsano al Tagliamento (PN) - Italy

Tel. +39 0434 695410

Fax +39 0434 695425

info@gaspardo.it

**MASCHIO GASPARDO NORTH AMERICA Inc.**

112 3rd Avenue East

DeWitt - IA 52742

Ph. +1 563 6596400

Fax +1 563 6596404

info@maschio.us

**MASCHIO-GASPARDO ROMANIA S.R.L.**

Strada Înfrăţirii, F.N.

315100 Chisineu-Cris (Arad) -România

Tel. +40 257 307030

Fax +40 257 307040

info@maschio.ro

**MASCHIO IBERICA S.L.**

**MASCHIO-GASPARDO POLAND**

**MASCHIO-GASPARDO UCRAINA**

**GASPARDO-MASCHIO TURCHIA**

**MASCHIO-GASPARDO CINA**

**MASCHIO-GASPARDO INDIA**