

**MASCHIO GASPARDO S.p.A.**

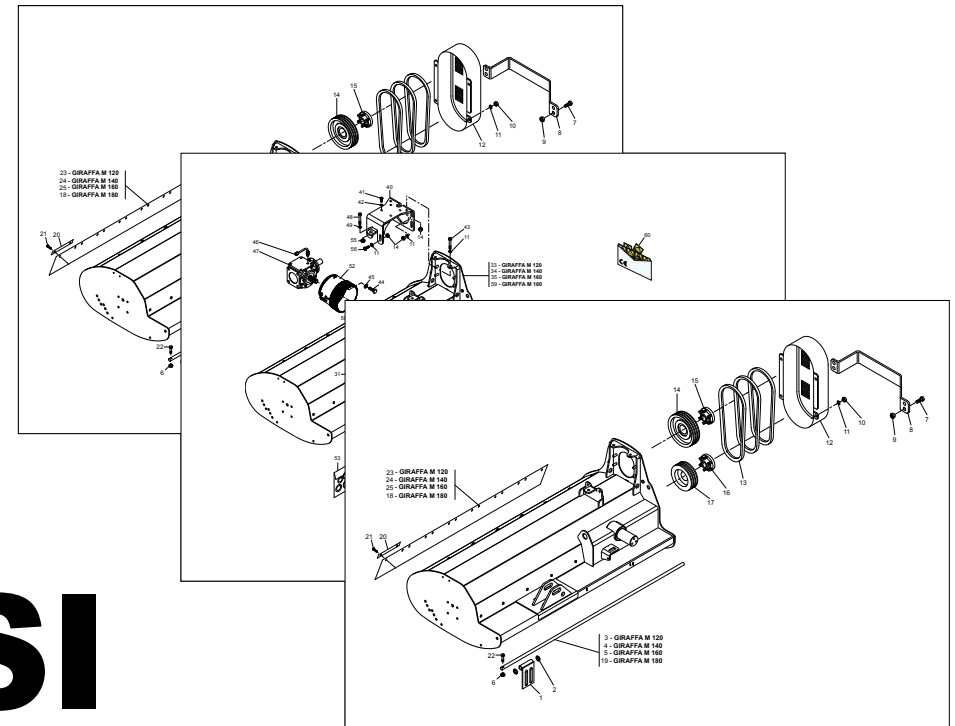

# GIRAFFA M - SI

**Cod: F07011713 2020-10**

- \*) Valido per Paesi UE
- \*) Valid for EU member countries
- \*) Valable dans les Pays UE
- \*) Gilt für EU-Mitgliedsländer
- \*) Válido para Países UE

- IT** PARTI DI RICAMBIO
- EN** SPARE PARTS
- DE** ERSATZTEILE
- FR** PIÈCES DÉTACHÉES
- ES** PIEZAS DE REPUESTO

**PARTI DI RICAMBIO****SPARE PARTS****ERSATZTEILE****PIECES DÉTACHÉES****RESPUESTOS**

Le ordinazioni delle parti di ricambio vanno fatte presso i nostri concessionari di zona e devono essere sempre corredate dalle seguenti indicazioni:

- **Tipo, modello e numero di matricola dell'attrezzatura.** Tali dati sono stampigliati nell'apposita targhetta di cui è dotata ogni attrezzatura.

- **Numero di codice della parte richiesta** rilevabile dal catalogo ricambi.

- **Descrizione del particolare e quantità richiesta.**

- **Numero della tavola.**

- **Mezzo di trasporto.** Nel caso questa voce non sia specificata, la Ditta Costruttrice, pur dedicando a questo servizio una particolare cura, non risponde di eventuali ritardi di spedizione dovuti a cause di forza maggiore.

Le spese di trasporto si intendono sempre a carico del destinatario. La merce viaggia a rischio e pericolo del committente anche se venduta franco destino.

**NOTA:** Il termine **(Dx) Destro** o **(Sx) Sinistro** della macchina o di parti di essa, è inteso guardando la macchina dalla parte posteriore. Le eccezioni saranno indicate.

*Orders must be transmitted through our area dealers and should always include the following indications:*

- **Type, model and serial number of the machine.** *These data are punched on the data plate with which every implement is equipped.*

- **Code number of the required spare part.** *This will be found in the spare parts catalogue.*

- **Description of the part and required quantity.**

- **Table number.**

- **Means of dispatch.** *If this item is not indicated, the Manufacturer, while dedicating particular care to this service, shall not be held responsible for delays in delivery caused by cases of force majeure.*

*Transport expenses shall always be at the consignee's charge. The goods travel at the purchaser's risk and peril even when sold ex destination.*

**NOTE:** *The symbols (Dx) right and (Sx) left, concerning the machine or single parts of it, are referred, as in the figure, to a rear view of them. Exceptions will be indicated.*

Die Bestellungen müssen bei unseren Gebietshändlern aufgegeben werden. Bei der Bestellung sind stets die folgenden Angaben zu machen:

- **Typ, Modell und Serien-Nummer des Geräts.** Diese Daten stehen auf dem Typenschild, mit dem jedes Gerät versehen ist.

- **Artikel Nr. der erforderlichen Ersatzteile.** Diese stehen im Ersatzteil-Katalog.

- **Beschreibung des Ersatzteils und die erforderliche Stückzahl.**

- **Tafelnummer.**

- **Versandmittel.** Wenn dieser Punkt nicht spezifiziert wird, haftet die Herstellerfirma nicht für etwaigen Lieferverzug aufgrund höherer Gewalt, auch wenn er diesen Service besonders aufmerksam abwickelt.

Die Frachtkosten gehen dagegen immer zu Lasten des Empfängers. Die Ware reist auf Gefahr und Risiko des Auftraggebers, auch wenn frei Haus Verkauft vereinbart worden ist.

**N.B.:** Die Merkzeichen **(Dx) rechts** und **(Sx) links** betreffen eine rückwärtige Aussicht der Maschine oder Teile von ihr (siehe Bild). Ausnahmen werden gezeigt.

*Les ordres doivent être effectués auprès de nos concessionnaires de zone en précisant les indications suivantes:*

- **Type, modèle et numéro de série de la machine.** *Ces données sont gravées sur la plaque d'identification de chaque outil.*

- **Numéro de code de la pièce détachée** *indiqué sur le catalogue des pièces détachées.*

- **Description de la pièce et quantité requise.**

- **Numéro de plan.**

- **Moyen d'expédition.** *Si cette rubrique n'est pas indiquée, le Constructeur, bien que soucieux de ce service, ne répond pas des retards d'expédition pour des causes de force majeure.*

*Les frais de transport sont toujours à la charge du destinataire. La marchandise voyage aux risques et périls de l'acheteur même si vendue franco de port.*

**N.B.:** *Les références (Dx) droit et (Sx) gauche de la machine ou des parties de la même, est entendue, comme de la figure, en regardant la machine de derriere dans le sens de marche.*

Los pedidos han de efectuarse en nuestros concesionarios de zona y deben incluir siempre las siguientes indicaciones:

- **Tipo, modelo y número de matrícula del equipo.** Dichos datos están impresos en la relativa placa presente en el equipo.

- **Número de código de la parte requerida** presente en el catálogo respuestas.

- **Descripción de la pieza y cantidad requerida.**

- **Numero de ilustración.**

- **Medio de transporte.** En caso que este ítem no esté especificado, el Fabricante, aún prestando la debidas consideraciones para este aspecto, no responde por eventuales retardos de env'o debidos a causas de fuerza mayor.

Los gastos de transporte se consideran siempre a cargo del destinatario. La mercadería viaja bajo riesgo y peligro del comprador, incluso cuando se vende franco destino.

**N.B.:** La referencia **(Dx) derecha** o **(Sx) izquierda** de la máquina o de sus componentes, se entiende, como en la figura, mirando la máquina por la parte trasera. Se indicarán las excepciones.

## INDICE

<i>N° Tavola</i>	<i>Descrizione</i>	<i>Pagina</i>
TAV. 010	Telaio e terzo punto.....	4
TAV. 020	Moltiplicatore 540 rpm .....	6
TAV. 030	Trasmissione.....	8
TAV. 040	Rotore .....	10
TAV. 050	Rullo e slitte .....	12
TAV. 060	Lamiera antiusura .....	14
TAV. 070	Impianto idraulico.....	16
TAV. 080	Supporti tabelle stradali .....	18
TAV. 090	Kit tabelle stradali G99600020.....	20
TAV. 100	Kit tabelle stradali G99600021 .....	22
TAV. 110	Cardano Bondioli .....	24

## INDEX

<i>N° Table</i>	<i>Description</i>	<i>Page</i>
TAV. 010	Frame and 3rd point hitch .....	4
TAV. 020	Gearbox 540 rpm .....	6
TAV. 030	Transmission .....	8
TAV. 040	Rotor .....	10
TAV. 050	Roller and skids .....	12
TAV. 060	Double skin frame .....	14
TAV. 070	Hydraulic plant .....	16
TAV. 080	Road kit supports .....	18
TAV. 090	Road transport kit G99600020.....	20
TAV. 100	Road transport kit G99600021 .....	22
TAV. 110	Bondioli cardan shaft .....	24

TAV. 010

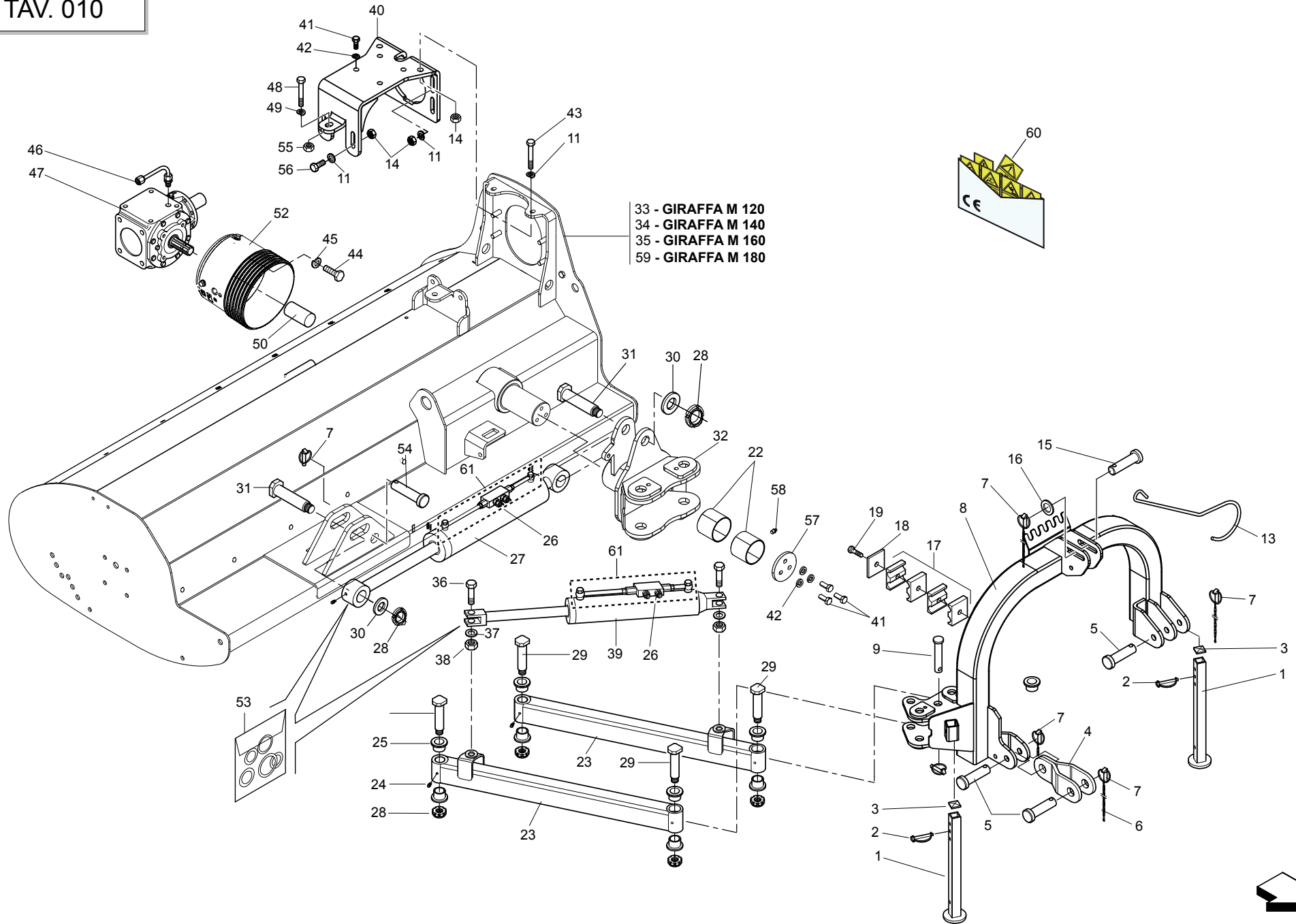

TELAIO E TERZO PUNTO / FRAME AND 3rd POINT HITCH

TAV. 010

Pos.	Cod.	Descrizione	Description	Description	Benennung	Descripcion
1	M56400922R	PIEDINO L=424,3	SUPPORT ASSEMBLY L=424,3	SUPPORT L=424,3	STANDER L=424,3	SOPORTE L=424,3
2	F02200562R	SPINA SICUR.D. 8X70 ZN	SNAP PIN D.8X 70 ZN	FICHE EL. D.8X70 ZN	SCHERSTIFT D.8X 70 ZN	CLAVIJA D.8X 70 ZN
3	F05100025R	TAPPO AD ALETTE 35X35 PLT NERO	PLUG	BOUCHON FERMETURE	VERSCHLUSSPFROPFEN	TAPONCLAUSURA
4	M41400546R	BIELLA	COMPL.PARALLEL LINK PISTONROD	BIELLE ATTELAGE	SCHUTZHOLM	BIELA ATAQUE
5	F20100049R	PERNO D22 L86 C43 TEST.D35 ZN	PIN D22 L86 C43 TEST.D35 ZN	GOUJON D22 L86 C43 TEST.D35 ZN	BOLZEN D.22	PERNO D22 L86 C43 TEST.D35 ZN
6	M58100930R	CATENELLA L=476	ASSEMBLY CHAIN DMP L=476	CHAINE L=476	KETTE L=476	CADENA L=476
7	F02200529R	SPINA SCATTO D.11 H58 ZN	SNAP PIN D.11 H58 ZN	FICHE A DETENTE D.11 H58 ZN	EINRASTSTIFT D.11 H58 ZN	CLAVIJA DE MUELLE D.11 H58 ZN
8	M41400401R	3 PUNTO ATTACCO GIRAFFA M	GIRAFFA M 3 POINT HITCH			
9	F20100138R	PERNO D28 L154 C43 TEST.D60 ZN	PIN D28 L154 C43 TEST.D60 ZN	GOUJON D28 L154 C43 TEST.D60ZN	BOLTZEN D28 L154 C43 ZN	PERNO D28 L154 C43 TEST.D60 ZN
11	F01410076R	ROS.M1213X24X2,5	WASHER 12 13X 24X2,5	RONDELLE 12 13X 24X2,5	SCHLEIBE M12 13X24X2,5 U6592 ZN	ARAND.M12 13X 24X2,5 U6592 ZN
13	F20120400R	GANCIO SOSTEGNO CARDANO	SHAFT HOOK SUPPORT	SUPPORT CARDAN	GELENKWELLE - HACKEN	SOPORTE CARDAN
14	F01220047R	DADO M12X1,25	NUT M12X1,25	ECROU M12X1,25 D980 8ZN	MUTTER M12X1,25	TUERCA M12X1,25 D980 8 ZN
15	F20100035R	PERNO D19 L90 C43 TEST.D35 ZN	PIN D19 L90 C43 TEST.D35 ZN	GOUJON D19 L90 C43 TEST.D35 ZN	BOLZEN D19 L86 C43	PERNO D19 L90 C43 TEST.D35 ZN
16	F01410112R	ROS.M18 19X 34X 3	WASHER M18 19X 34X 3	RONDELLE M18 19X 34X 3	SCHLEIBE M18 19X 34X 3 U6592 ZN	ARANDELA M18 19X 34X3 U6592 ZN
17	F03151019R	COPIA COLL.2T D12 1V I=00 M8	COLLAR PAIR 2T D12 1V I=00 M8		BAND PAAR 2T D12 1V I=00 M8	
18	M58100628R	PIATTO SUPERIORE ZPG	UPPER PLATE	PLAT SUPERIEUR	OBENE PLATTE	PLATO SUPERIOR
19	F01020077R	VITE M8X1,25X60	SCREW M8X1,25X60 U5737 8.8ZN	VIS M8X1,25X60 U5737 8.8ZN	SCHRAUBE M8X1,25X60	TORN. M8X1,25X60 U5737 8.8ZN
22	F04100109R	BOCCOLA D=75 D=70 L=60 AUTOLUB	BUSHING D=75 D=70 L=60	DOUILLE D=75 D=70 L=60	BUECHSE D=75 D=70 L=60	CASQUILLO D=75 D=70 L=60
23	M41400582R	COMP. PARALLELOGRAMMA SMALL GF	COMPLETE PARALLELOGRAM SMALLGF			
24	F01100011R	ING.M 6X1 7663A 9SMNPB28 Z	GREASE NIPPLE M6X1 7663-A ZN	GRAISS. A BILLE M6X1 7663A ZN	SCHMIERBUECHE M6X1 7663-A ZN	ENG.M 6X1 7663-A 9SMNPB28 ZN
25	M07400929R	BOCCOLA D=30 D=40 L=30	BUSHING D=30 D=40 L=30	BOUCLE D=30 D=40 L=30	BUECHSE D=30 D=40 L=30	ARANDELA D=30 D=40 L=30
26	F03080081R	NIPPLO M3 8 SEAL ML10 ZN	NIPPLE M3 8 SEAL ML10 ZN		NIPPEL M3 8 DICHTUNG ML10 ZN	
27	M41400580R	MARTINETTO I.A=100 C=361 L=744	HYDR.ADJ. ID.A=100 C=361 L=744	HYDR.ADJ. ID.A=100 C=297 L=820	HYDRAUL.SPINDELVERSTELLUNG	GATO HYDRAULICO
28	F02010111R	GHIERA AU.GUP M30X1,5 T.4H ZN	SELF LOCKING NUT M30X1,5	COLLIER AUTOBL. M30X1,5	SELBSTSP. NUTMUTTER M30X1,5	VIROLA AUTOBL. M30X1,5
29	M20700531R	PERNO D30 L168	PIN D30 L.168	GOUJON D30 L.168	BOLZEN D30 L.168	PERNO D30 L168
30	F01410168R	ROS.M30 31X 56X 4	WASHER M30 31X56X4	RONDELLE M30 31X56X4	UNTERLEGSCHEIBE M30 31X56X4 ZN	ARANDELLA M30 31X56X4 ZN
31	M07400598R	COMP.PERNO D=30 L=109	PIN D=30 L=109	GOUJON D=30 L=109	STIFT D=30 L=109	PERNO D=30 L=109
32	M41400568R	GIUNTO MOVIMENTAZIONE	JOINT		GELENK	
33	M41412012R	TELAIO GIRAFFETTA M H SI 12	GIRAFFETTA FRAME M H SI 12			
34	M41414012R	TELAIO GIRAFFETTA M H SI 14	GIRAFFETTA FRAME M H SI 14			
35	M41416012R	TELAIO GIRAFFETTA M H SI 16	GIRAFFETTA FRAME M H SI 16			
36	F01010169R	VITE M20X1,5X65	SCREW M20X1,5X65 U5738 8.8ZN	VIS M20X1,5X65 U5738 8.8ZN	SCHRAUBE M20X1,5X65	TORNIL. M20X1,5X65 U5738 8.8ZN
37	F01410124R	ROS.M20 21X 37X 3	WASHER M20 21X 37X 3	RONDELLE M20 21X 37X 3	MUTTER M20 21X 37X 3 U6592 ZN	ARAND.M20 21X 37X 3 U6592 ZN
38	F01220093R	DADO M20X1,5	NUT M20X1,5	ECROU M20X1,5 D980 8ZN	MUTTER M20X1,5	TUERCA M20X1,5 D980 8ZN
39	M41400581R	MARTINETTO I.A=50 C=225 L=695	HYDR.ADJUSTER A=50 C=225 L=695	MANIVELLE HYDRAULIQUE	HYDRAUL.SPINDELVERSTELLUNG	GATO HYDRAULICO
40	M41400414R	PIASTRA SUPP.CAMBIO GIRAFFA M	GIRAFFA M GEARBOX SUPP.PLATE			
41	F01010283R	VITE M12X1,25X30	SCREW M12X1,25X30 U5740 8.8ZN	VIS M12X1,25X30 U5740 8.8ZN	SCHRAUBE M12X1,25X30	TORNIL.M12X1,25X30 U5740 8.8ZN
42	F01480123R	ROS.G 12,5X22,9X 4	GROVER WASHER M12 ZGP EXTRA P.	GROVER RONDELLE M12 ZGP EXTRA	UNTERLEGSCHEIBE M12 ZGP EXTRA	ARANDELA M12 ZGP EXTRA P.
43	F01010298R	VITE M12X1,25X80	SCREW M12X1,25X80 U5740 8.8ZN	VIS M12X1,25X80 U5740 8.8ZN	SCHRAUBE M12X1,25X80	TORNIL.M12X1,25X80 U5740 8.8ZN
44	F01020436R	VITE M8X1,25X20	SCREW M8X1,25X20 U5739 8.8ZN	VIS M8X1,25X20 U5739 8.8ZN	SCHRAUBE M8X1,25X20	TORN. M8X1,25X20 U5739 8.8ZN
45	F01410051R	ROS.M8 8,4X 17X1,6	WASHER M8 8,4X17X1,6	RONDELLE M8 8,4X17X1,6	SCHLEIBE M8 8,4X17X1,6 U6592 ZN	ARAND.M8 8,4X 17X1,6 U6592 ZN
46	M07400216R	PROLUNGA SFIATO 90	BREATHER PLUG 90	BOUCHON DE SOUPIRAIL 90	ENTLUEFTERSTOPFEN 90	TAPON RESPIRADERO 90
47	M07400220R	MULTIPLICATORE GIRAFFA 540 RP	MULTIPLI.GEARB.MASCHIO 540 RPM			
48	F01010323R	VITE M14X1,5X70	SCREW M14X1,5X70 U5740 8.8ZN	VIS M14X1,5X70 U5740 8.8ZN	SCHRAUBE M14X1,5X70	TORNIL. M14X1,5X70 U5740 8.8ZN
49	F01410088R	ROS.M14 15X 28X2,5	WASHER M14 15X 28X2,5	RONDELLE M14 15X 28X2,5	SCH.M14 15X 28X2,5 U6592 ZB	ARA.M14 15X 28X2,5 U6592 ZB
50	G19002131R	PROTEZIONE P.D.P.	PDP GUARD		SCHUTZ P.D.P.	PROTECCI N T.D.F.
52	F08013132R	KIT COPERCHIO CUFFIA CIRC.	COVER KIT CIRCULAR HEADSET			
53	F03100327R	KIT.GUARNIZIONI M41400580-581	KIT.GU.M41400580-582			
54	F20100078R	PERNO D28 L93 C43 TEST.D45 ZN	PIN D.28	GOUJON D.28	BOLZEN D.28	PERNO D.28
55	F01220059R	DADO M14X1,5	NUT M14X1,5 D980 8ZN	ECROU M14X1,5 D980 8ZN	MUTTER M14X1,5	TUERCA M14X 1,5 D980 8 ZN
56	F01010291R	VITE M12X1,25X40	SCREW M12X1,25X40 U5740 8.8ZN	VIS M12X1,25X40 U5740 8.8ZN	SCHRAUBE M12X1,25X40	TORNIL.M12X1,25X40 U5740 8.8ZN
57	M41400590R	ROSETTA DI BLOCCAGGIO	PLANE WASHER		PLANE SCHEIBE	
58	F01100061R	ING.M10X1 7663A 9SMNPB28 Z	GREASE NIPPLE M10X1 7663-A ZN	GRAISSEUR M10X1 7663-A ZN	SCHMIERBUECHSE M10X1 7663-A ZN	ENGRASADOR M10X1 7663-A ZN
59	M41418012R	TELAIO GIRAFFETTA M H SI 18	GIRAFFETTA FRAME M H SI 18			
60	F20030241R	KIT.ET.CE TRINCIA	KIT CE LABELS MULCHERS		KIT AUFKLEBER F R MULCHGER TE	
61	F03151158R	KIT VALVOLA BLOCCO 3 8 7014200	KIT VALVE BLOCK.3 8 7014200	SOUPAPE D ARRET AUTOMATIQUE	AUTOM. VENTIL 3 8	VALVULA DE CRIERRE 3 8 7014200

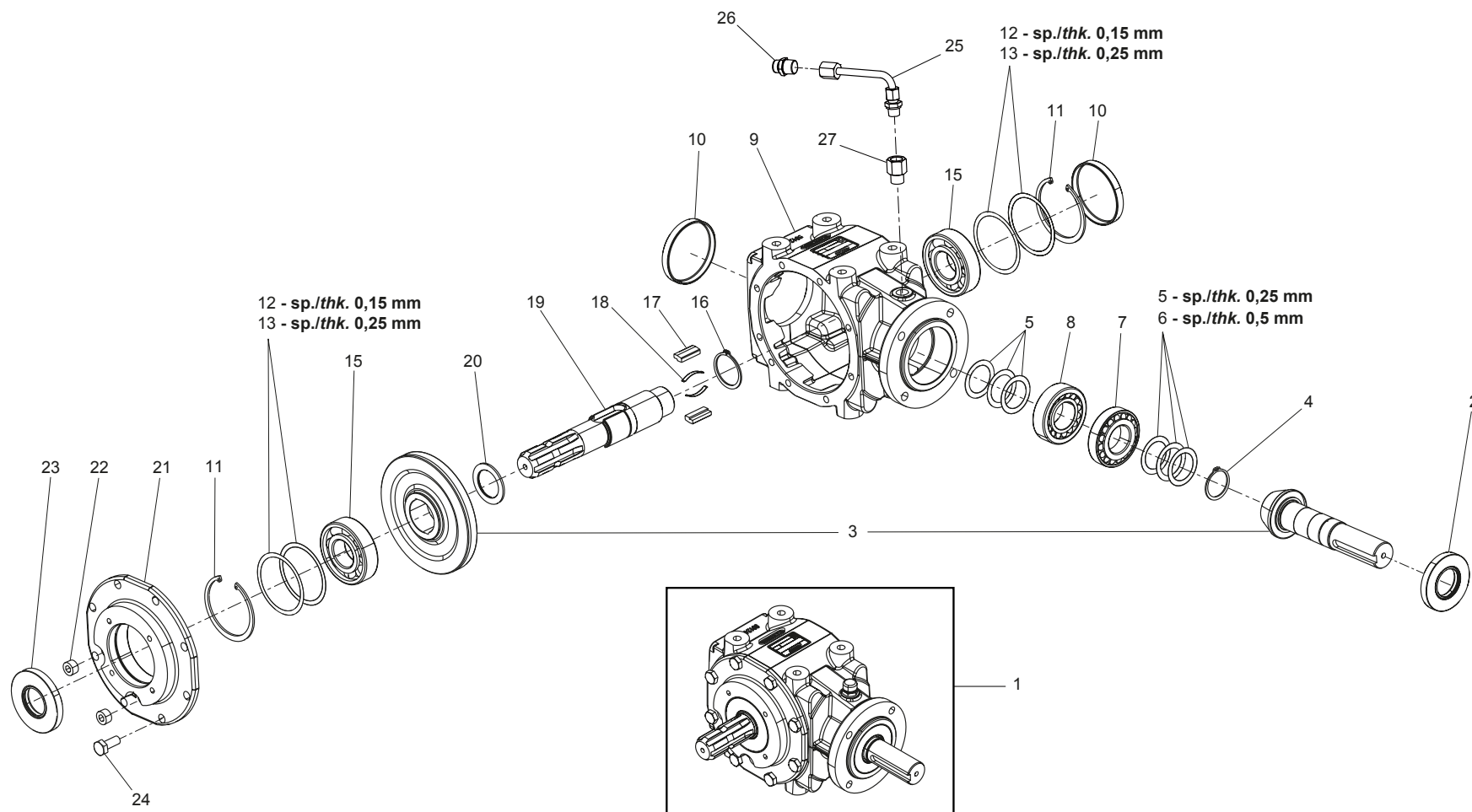

MOLTIPLICATORE 540 rpm / GEARBOX 540 rpm

TAV. 020

Pos.	Cod.	Descrizione	Description	Description	Benennung	Description
1	M07400220R	MOLTIPLICATORE GIRAFFA 540 RP	MULTIPLI.GEARB.MASCHIO 540 RPM			
2	F03010088R	ANELLO T.AS.35X 72X10 D3760NB	OIL SEAL 35X72X10	PARA-HUILLE 35X72X10	OELABDICHTUNG 35X72X10	PARA-ACEITE 35X72X10
3	M07400224R	COPPIA CONICA 12 36	BEVEL GEAR PAIR 12 36	COUPLE CONIQUE 12 36	KEGELRITZELSATZ 12 36	PAR CONICO 12 36
4	F02050146R	ANELLO E. DE 35X 1,5 U7435 C70	ELASTIC RING DE 35X 1,5 U7435	BAGUE ELASTIQUE DE 35X 1,5	RING DE 35X 1,5 U7435 C70	ANILLO DE 35X 1,5 U7435 C70
5	T24001215R	ROSETTA D=48 D=35,5 L=0,25	WASHER D=48 D=35,5 L=0,25	ROSETTE D=48 D=35,5 L=0,25	SCHEIBE D=48 D=35,5 L=0,25	ARANDELLA D=48 D=35,5 L=0,25
6	T24001216R	ROSETTA D=48 D=35,5 L=0,5	WASHER D=48 D=35,5 L=0,5	ROSETTE D=48 D=35,5 L=0,5	SCHEIBE D=48 D=35,5 L=0,5	ARANDELLA D=48 D=35,5 L=0,5
7	F04050014R	CUSC.D35 D72 T18,25 30207	BEARING D35 D72 T18,25 30207	ROUL. D35 D72 T18,25 30207	LAGER 30207	COJINETE D35 D72 T18,25 30207
8	F04050070R	CUSC.D35 D72 T24,25 32207	BEARING D35 D72 T24,25 32207	ROUL. D35 D72 T24,25 32207	LAGER 32207	COJINETE D35 D72 T24,25 32207
9	M03400020R	CORPO RIDUTTORE INT.	GEARBOX			
10	F03011026R	TAPPO CHIUSURA D=80 X 10 GA	COVER D. 80X10	BOUCHON 80X10	DECKEL 80X10	CORCHO 80X10
11	F02050425R	ANELLO E. DI 80X 2,5 U7437 C70	SEEGER RING D.80	BAGUE SEEGER D.80	SEEGERRING D.80	ANILLO E. DI 80X 2,5 U7437 C70
12	T24001213R	ROSETTA D=79,6 D=69,4 L=0,15	WASHER D=79,6 D=69,4 L=0,15	ROSETTE D=79,6 D=69,4 L=0,15	SCHEIBE D=79,6 D=69,4 L=0,15	RANDELLA D=79,6 D=69,4 L=0,15
13	T24001214R	ROSETTA D=79,6 D=69,4 L=0,25	WASHER D=79,6 D=69,4 L=0,25	ROSETTE D=79,6 D=69,4 L=0,25	SCHEIBE D=79,6 D=69,4 L=0,25	RANDELLA D=79,6 D=69,4 L=0,25
15	F04010216R	CUSC.D35 D80 B21 6307	BEARING D35 D80 B21 6307	ROUL. D35 D80 B21 6307	LAGER 6307	COJINETE D35 D80 B21 6307
16	F02050179R	ANELLO E. DE 42X1,75 U7435	COMPRESSION RING D.42	ANNEAU RESSORT D.42	RING D.42	ANILLO D.42
17	T24001204R	LINGUETTA DI INNESTO	KEY	CLAVETTE	KEIL	LLAVE
18	T24001203R	MOLLA	SPRING	RESSORT	FEDER	MUELLE
19	M07400221R	ALBERO PER CORONA CONICA	HALF-SHAFT	ARBRE COURONNE	HALBWELLE	MEDIO ARBOL
20	M07400223R	ROSETTA D=52 D=35,4 S=2,5	WASHER D=52 D=35,4 S=2,5	ROSETTE D=52 D=35,4 S=2,5	SCHEIBE D=52 D=35,4 S=2,5	ARANDELLA D=52 D=35,4 S=2,5
21	T24001208R	FLANGIA CORPO TRASMISSIONE	GEARBOX COVER	COUVERCLE BOITE A VITESSES	GETRIEBEDECKEL	TAPA CAJA CAMBIO
22	F03011026R	TAPPO CHIUSURA D=80 X 10 GA	COVER D. 80X10	BOUCHON 80X10	DECKEL 80X10	CORCHO 80X10
23	F03010265R	ANELLO T.AS 35X 80X10 D3760NBR	RING T.AS 35X80X10 D3760 NBR	BAGUE T.AS 35X 80X10 D3760 NBR	SCHUTZRING 35X80X10 D3760 NBR	INEL T.AS 35X80X10 D3760 NBR
24	F01010244R	VITE M10X1,25X25	SCREW M10X1,25X25 U5738 8.8ZN	VIS M10X1,25X25 U5738 8.8ZN	SCHRAUBE M10X1,25X25	TORNIL.M10X1,25X25 U5738 8.8ZN
25	M07400216R	PROLUNGA SFIATO 90	BREATHER PLUG 90	BOUCHON DE SOUPIRAIL 90	ENTLUEFTERSTOPFEN 90	TAPON RESPIRADERO 90
26	F03150718R	TAPPO 3 8 GAS CON SFIATO	GAS BREATHER PLUG 3 8	BOUCHON D HUILE SOUPIRAIL	OELENTLUEFTERSTOPFEN	TAPON ACEITE
27	F03020113R	PROLUNGA M F 3 8 L22 L.TOT=33	EXTENSION M F 3 8 L22 L.TOT=33			

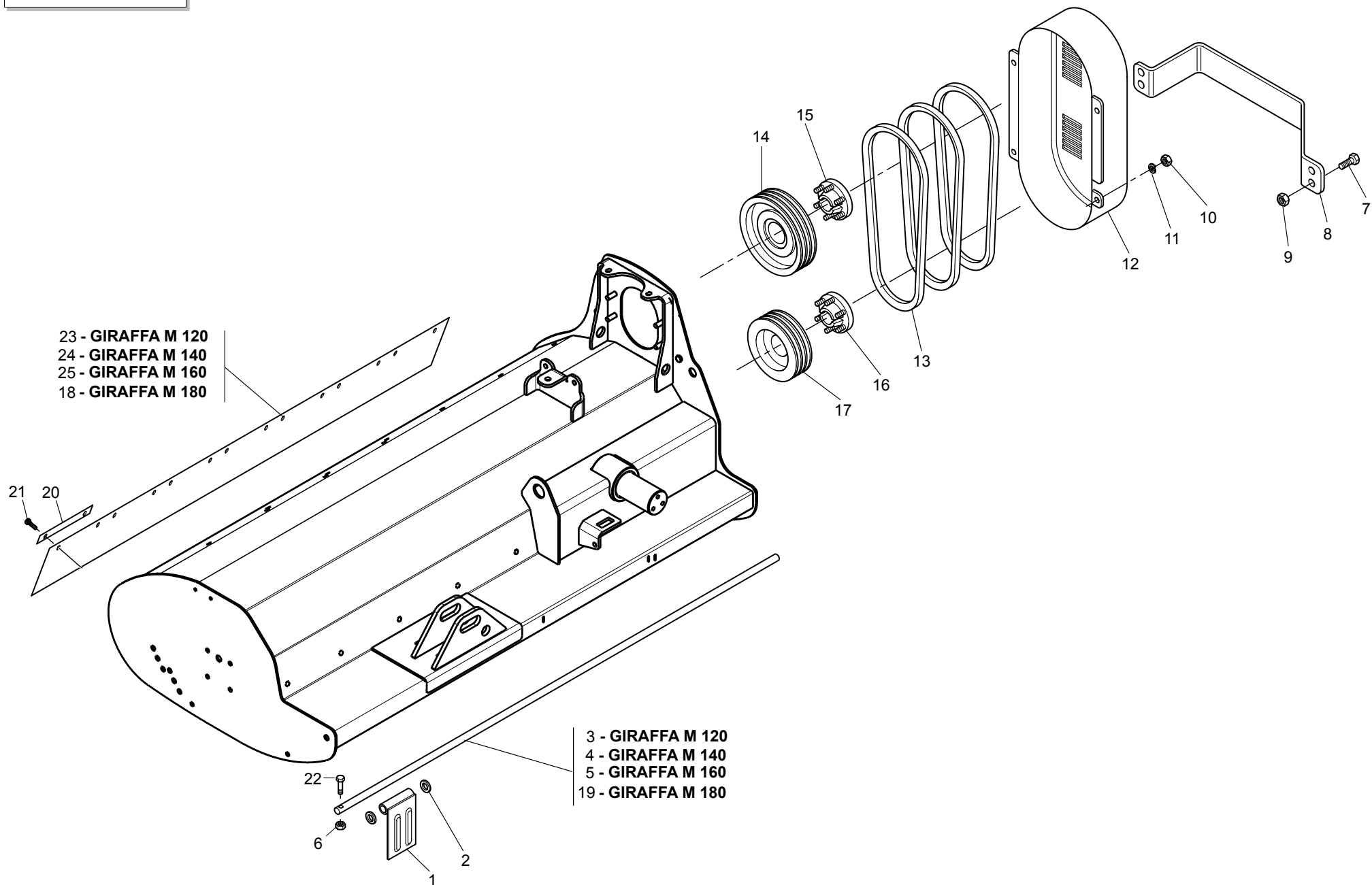



**TRASMISSIONE / TRANSMISSION**

**TAV. 030**

Pos.	Cod.	Descrizione	Description	Description	Benennung	Description
1	M24400518R	BANDELLA PROTEZ. 93X170 ZG	PROTECTION BAR	BANDE PROTECTION	SCHUTZWORNE	ALETA PROTECCION
2	F01410100R	ROS.M16 17X30X 3	WASHER M16 17X30X3	RONDELLE M16 17X30X3	SCHRAUBE M16 17X 30X3 U6592 ZN	ARAND.M16 17X 30X 3 U6592 ZN
3	T21115016R	ASTA PER BANDELLE	PIN	GOUJON	BOLZEN	PERNO
4	T21135016R	ASTA PER BANDELLE	PIN	GOUJON	BOLZEN	PERNO
5	T21155016R	ASTA PER BANDELLE	PIN	GOUJON	BOLZEN	PERNO
6	F01220011R	DADO M6X1	NUT M6X1	CROU M6X1 D980 8ZN	MUTTER M6X1	TUERCA M6X1 D980 8 ZN
7	F01010283R	VITE M12X1,25X30	SCREW M12X1,25X30 U5740 8.8ZN	VIS M12X1,25X30 U5740 8.8ZN	SCHRAUBE M12X1,25X30	TORNIL.M12X1,25X30 U5740 8.8ZN
8	M41400556R	PROTEZIONE CARTER	CARTER PROTECTION	CARTER PROTECTION	GEHAEUSE SCHUTZ	PROTECCION CARTER
9	F01220047R	DADO M12X1,25	NUT M12X1,25	ECROU M12X1,25 D980 8ZN	MUTTER M12X1,25	TUERCA M12X1,25 D980 8 ZN
10	F01220034R	DADO M10X1,25	NUT M10X1,25	ECROU M10X1,25 D980 8GALV.	MUTTER M10X1,25	TUER.M10X1,25 D980 8 ZB
11	F01410064R	ROS.M10 10,5X 20X 2	WASHER M10 10,5X20X2	RONDELLE M10 10,5X20X2	SCHEIBE M10 10,5X20X2 U6592 ZN	ARAND.M10 10,5X 20X 2 U6592 ZN
12	T16003150R	COMP.CARTER	COMPLETE CARTER		GEHAEUSE	
13	F06010039R	CINGHIA SPBX L=1320	BELT SPBX L=1320	COURROIE L=1320	SCHAUBE SPBX L=1320	CORREA SPBX L=1320
14	T16003002R	PULEGGIA SPB MOTRICE D=225 3V	DRIVING PULLEY	POULIE TIRANTE	ZIEHEN RIEMEN	ROLDANA DE TIRAR
15	F06060036R	CALETTATORE AUTOC. 33X80	SELF CENTR.CLAMP.EL.33X80	EMBOITAGE AUOBL. 33X80	SELBSTPERR.VERKEILEN 33X80	ENSAMBLADURA AUTOBL. 33X80
16	F06060037R	CALETTATORE AUTOCENTR.35X80	SELF CENTR.CLAMP.EL.35X80	EMBOITAGE AUOBL. 35X80	SELBSTPERR.VERKEILEN 35X80	ENSAMBLADURA AUTOBL. 35X80
17	T22003001R	PULEGGIA ROTORE DP=160	DRIVING PULLEY	POULIE TIRANTE	ZIEHEN RIEMEN	ROLDANA DE TIRAR
18	M33418544R	PROTEZ.POSTER.180	REAR PROTECTION 180	PROTECTION ARRIERE 180	HINTERER SCHUTZ 180	PROTECCION TRASERA 180
19	T21185016R	ASTA PER BANDELLE BCA180-BL170	PIN	GOUJON	BOLZEN	PERNO
20	M07400953R	PIATTO PER ATTACCO GOMMA	PLATE	PLAT	PLATTE	PLATO
21	F02250160R	RIVETTO STR. 6,4X22 ACCIAIO	RIVET	RIVET	KUPFFERNIET	REMACHE
22	F01040066R	VITE M6X1X35	SCREW M6X1X35	VIS M6X1X35 U5931 8.8ZN	SCHRAUBE M6X1X35	TORNILLO M6X1X35 U5931 8.8ZN
23	M33412544R	PROTEZ.POSTER.120	REAR PROTECTION 120	PROTECTION ARRIERE 120	HINTERER SCHUTZ 120	PROTECCION TRASERA 120
24	M33414544R	PROTEZ.POSTER.140	REAR PROTECTION 140	PROTECTION ARRIERE 140	HINTERER SCHUTZ 140	PROTECCION TRASERA 140
25	M33416544R	PROTEZ.POSTER.160	REAR PROTECTION 160	PROTECTION ARRIERE 160	HINTERER SCHUTZ 160	PROTECCION TRASERA 160

**KIT ROTORE+COLTELLI**

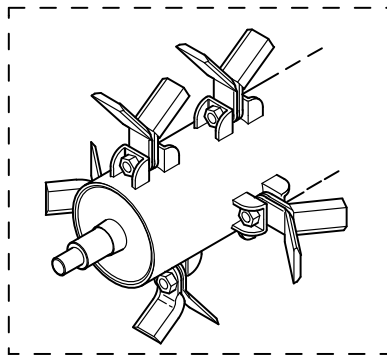

- 20 - GIRAFFA M 120
- 21 - GIRAFFA M 140
- 22 - GIRAFFA M 160
- 6 - GIRAFFA M 180

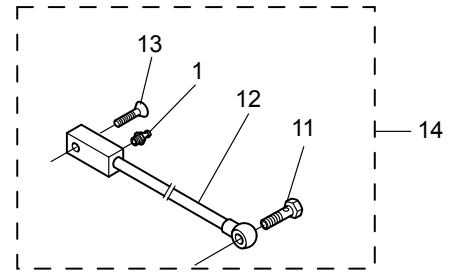

**KIT ROTORE+MAZZE**

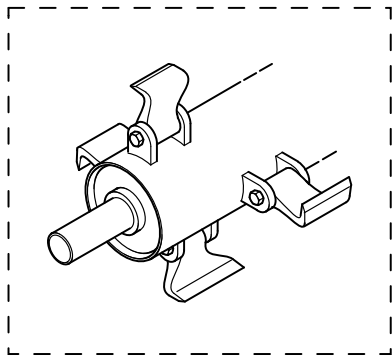

**KIT ROTOR+KNIVES**

- 23 - GIRAFFA M 120
- 24 - GIRAFFA M 140
- 25 - GIRAFFA M 160
- 7 - GIRAFFA M 180

**KIT ROTOR+HAMMER**

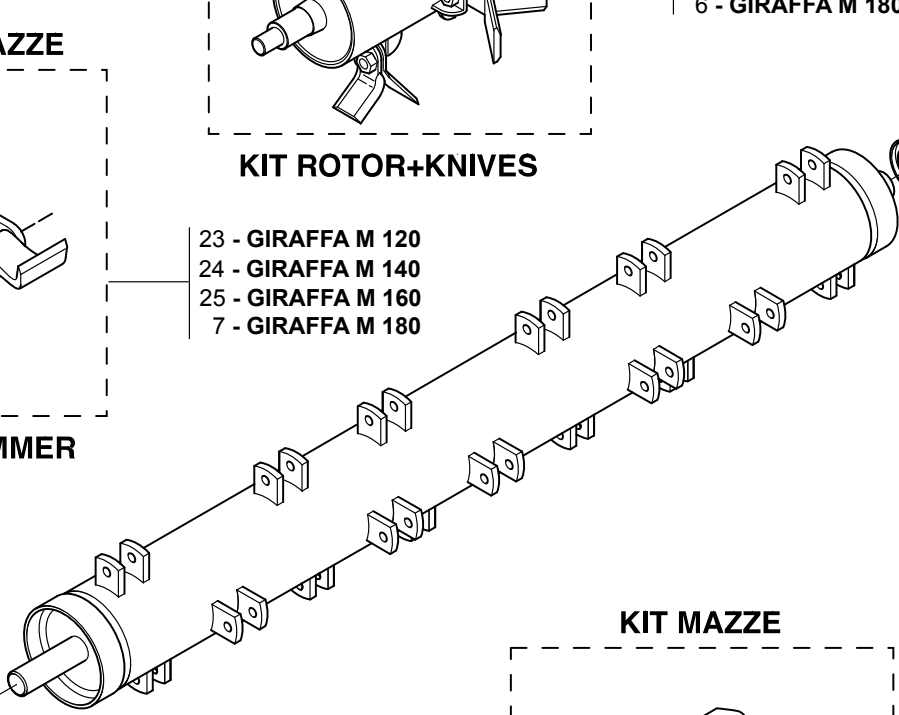

**KIT COLTELLI**

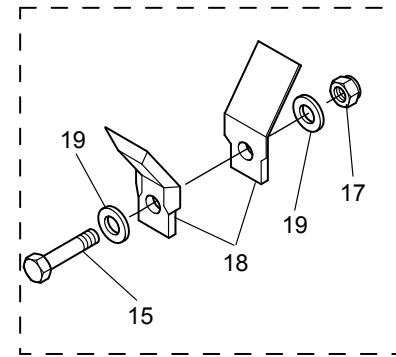

**KIT KNIVES**

**KIT MAZZE**

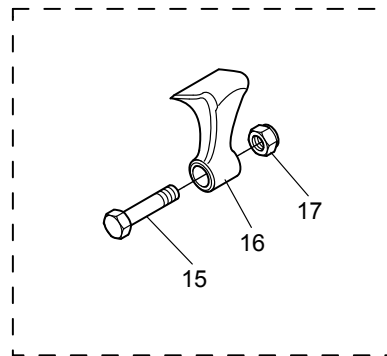

**KIT HAMMER**

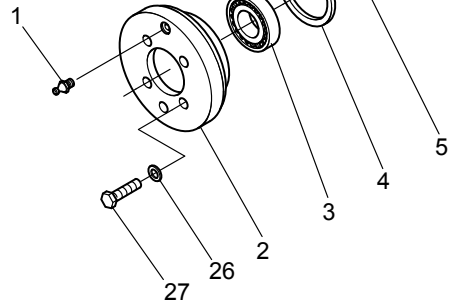

**ROTORE / ROTOR**

**TAV. 040**

Pos.	Cod.	Descrizione	Description	Description	Benennung	Description
1	F01100011R	ING.M 6X1 7663A 9SMNPB28 Z	GREASE NIPPLE M6X1 7663-A ZN	GRAISS. A BILLE M6X1 7663A ZN	SCHMIERBUECHE M6X1 7663-A ZN	ENG.M 6X1 7663-A 9SMNPB28 ZN
2	M22400406R	SUPPORTO ROTORE DX	RIGHT ROTOR SUPPORT	SUPPORT ROTOR DROITE	ROTORHALTER RECHTE	SOPORTE ROTOR DERECHO
3	F04010032R	CUSC.D35 D72 B23 22207	BEARING D35 D72 B23 22207	ROUL. D35 D72 B23 22207	LAGER D35 D72 B23 22207	COJINETE D35 D72 B23 22207
4	F02050403R	ANELLO E. DI 72X 2,5 U7437 C7	SEEGER RING E.72X2,5 U7437 C70	SEEGER E. 72X 2,5 U7437 C70	SEEGERING E. 72X 2,5 U7437 C70	ANILLO E. DI 72X 2,5 U7437 C7
5	F03010142R	ANEL. T.A 45X 72X 8 D3760NBR	OIL SEAL 45X 72X 8 D3760NBR			
6	M334184021R	ROTORE BARBI 180 C18 NO SUPP.	ROTOR BARBI 180 BLADE 18		ROTOR BARBI 180 C18 NO HALTER	
7	M334184011R	ROTORE BARBI180 M20 NO SUPP.	ROTOR BARBI 180 HAMMER 20		ROTOR BARBI 180 M20 NO HALTER	
9	M22400405R	SUPPORTO ROTORE SX	LEFT ROTOR SUPPORT	SUPPORT ROTOR GAUCHE	ROTORHALTER LINKS	SOPORTE ROTOR IZQUIERDO
10	F03010086R	ANELLO T.A 35X 62X 7 D3760NBR	OIL SEAL 35X62X7	PARE-HUILE 35X62X7	OELABDICHTUNG 35X62X7	PARA-ACEITE 35X62X7
11	T24004003R	VITE FORATA PER INGRASSAGGIO	BOLT	VIS	SCHRAUBE	TORN.PERFORADO PARA ENGRASAR
12	T24004000R	ASSIEME INGRASSATORE	GREASE NIPPLE	GRAISSEUR	SCHMIERNIPPEL	ENGRASADOR
13	F01030058R	VITE M8X1,25X30	SCREW M8X1,25X30	VIS M8X1,25X30 U5933 10.9ZD	SCHRAUBE M8X1,25X30	TORN. M8X1,25X30 U5933 10.9ZD
14	T24004000R	ASSIEME INGRASSATORE	GREASE NIPPLE	GRAISSEUR	SCHMIERNIPPEL	ENGRASADOR
15	F20110091R	VITE M16X1.5X85	SCREW M16X1.5X85 SPEC.BR.8.8	VIS M16X1.5X85 SPEC. BR.8.8	SCHRAUBE M16X1.5X85	TORNILLO M16X1.5X85 SPEC.BR.8.8
16	M07400950R	MAZZA 20 STAMPATA	HAMMER 20	MARTEAU 20 BARBI-GIRAFETTA	SCHLEGEL	MARTILLO 20
17	F01230084R	DADO M16X1,5	NUT M16X1,5	ECROU M16X1,5 D982 6ZN	MUTTER M16X1,5	TUERCA M16X1,5 D982 6ZN
18	M07400954R	COLTELLO 18	KNIFE*18	COUTEAU 18 GALVANISE P		
19	T21004046R	DISTANZIALE COLTELLO ZPG	SPACER KNIFE	DIUTEAU TIPE ZN	SCHEIBE 04-06	
20	M334124021R	ROTORE 120 COLT. 18	ROTOR 120 BLADE 18	ROTOR 120 COUTEAUX 18	LAEUFER 120 MESSER 18	ROTOR 120 CUCHILLO 18
21	M334144021R	ROTORE 140 COLT. 18	ROTOR 140 BLADE 18	ROTOR 140 COUTEAUX 18	LAEUFER 140 MESSER 18	ROTOR 140 CUCHILLO 18
22	M334164021R	ROTORE 160 COLT. 18	ROTOR 160 BLADE 18	ROTOR 160 COUTEAUX 18	LAEUFER 160 MESSER 18	ROTOR 160 CUCHILLO 18
23	M334124011R	ROTORE 120 M20 NO SUPP.	ROTOR 120 HAMMER 20	ROTOR 120 MARTEAUX 20	LAEUFER 120 SCHLEGEL 20	ROTOR 120 MARTILLO 20
24	M334144011R	ROTORE BARBI 140 M20 NO SUPP.	ROTOR 140 HAMMER 20	ROTOR 140 MARTEAUX 20	LAEUFER 140 SCHLEGEL 20	ROTOR 140 MARTILLO 20
25	M334164011R	ROTORE BARBI 160 M20 NO SUPP.	ROTOR 160 HAMMER 20	ROTOR 160 MARTEAUX 20	LAEUFER 160 SCHLEGEL 20	ROTOR 160 MARTILLO 20
26	F01480123R	ROS.G 12,5X22,9X 4	GROVER WASHER M12 ZGP EXTRA P.	GROVER RONDELLE M12 ZGP EXTRA	UNTERLEGSCHIEBE M12 ZGP EXTRA	ARANDELA M12 ZGP EXTRA P.
27	F01010283R	VITE M12X1,25X30	SCREW M12X1,25X30 U5740 8.8ZN	VIS M12X1,25X30 U5740 8.8ZN	SCHRAUBE M12X1,25X30	TORNIL.M12X1,25X30 U5740 8.8ZN

- 12 - GIRAFFA M 120
- 13 - GIRAFFA M 140
- 14 - GIRAFFA M 160
- 15 - GIRAFFA M 180

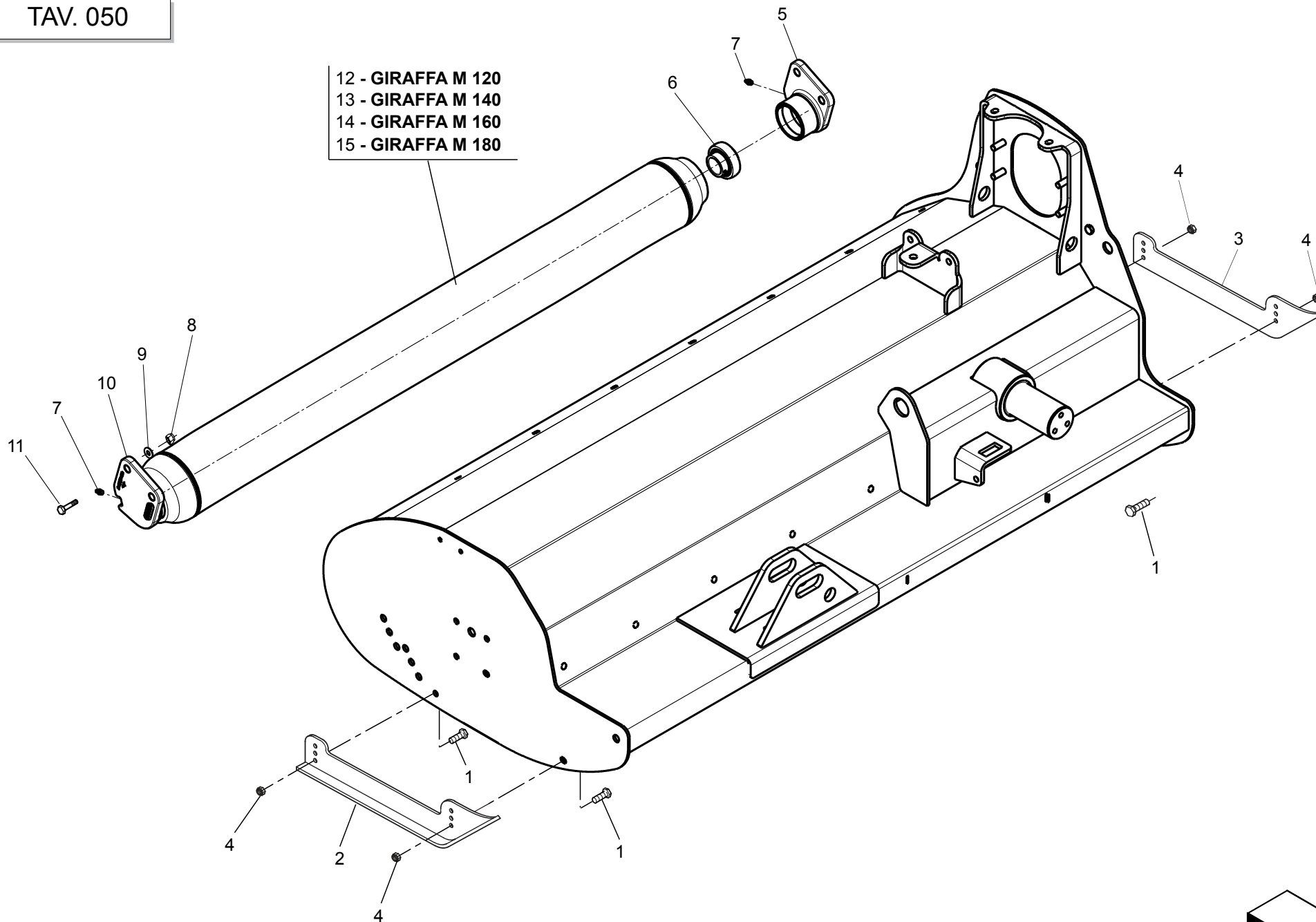

**RULLO E SLITTE / ROLLER AND SKIDS**

**TAV. 050**

Pos.	Cod.	Descrizione	Description	Description	Benennung	Description
1	F01010283R	VITE M12X1,25X30	SCREW M12X1,25X30 U5740 8.8ZN	VIS M12X1,25X30 U5740 8.8ZN	SCHRAUBE M12X1,25X30	TORNIL.M12X1,25X30 U5740 8.8ZN
2	M30400536R	SLITTA LATO ESTERNO GF	SIDE PANEL SKID		GLEITKUFE RECHTS	
3	M30400535R	SLITTA LATO TRASMISSIONE	TRANSMISSION SIDE SKID		GLEITKUFE LINKS	
4	F01220047R	DADO M12X1,25	NUT M12X1,25	ECROU M12X1,25 D980 8ZN	MUTTER M12X1,25	TUERCA M12X1,25 D980 8 ZN
5	M21700615R	SUPPORTO SX RULLO	SUPPORT ROLLER LF		HALTER WALZE LF	
6	F04010361R	CUSC. YAR 207-2FW VA201	BEARING YAR 207-2FW VA201	ROUL. YAR 207-2FW VA201	LAGER YAR 207	COJIN.YAR 207-2FW VA201
7	F01100048R	ING.M 8X1,25 7663A 9SMNPB28 Z	GREASE NIPPLE M8X1,25 U7663A	GRAISSEUR A BILLES M8X1,25	SCHMIERBUECHSE M8X1,25 7663A	ENG.M 8X1,25 7663A 9SMNPB28 Z
8	F01220059R	DADO M14X1,5	NUT M14X1,5 D980 8ZN	ECROU M14X1,5 D980 8ZN	MUTTER M14X1,5	TUERCA M14X 1,5 D980 8 ZN
9	F01410088R	ROS.M14 15X 28X2,5	WASHER M14 15X 28X2,5	RONDELLE M14 15X 28X2,5	SCH.M14 15X 28X2,5 U6592 ZB	ARA.M14 15X 28X2,5 U6592 ZB
10	M21700613R	SUPPORTO DX RULLO	SUPPORT ROLLER RH		HALTER WALZE RECHTS	
11	F01010318R	VITE M14X1,5X40	SCREW M14X1,5X40 U5740 8.8ZN	VIS M14X1,5X40 U5740 8.8ZN	SCHRAUBE M14X1,5X40	TORNIL. M14X1,5X40 U5740 8.8ZN
12	M33412611R	RULLO POSTERIORE D=139,7	REAR ROLLER D=139,7	ROULEAU ARR. D=139,7	HECK WALZE D=139,7	RODILLO TRASERO D=139,7
13	M33414611R	RULLO POSTERIORE D=139,7	REAR ROLLER D=139,7	ROULEAU ARR. D=139,7	HINT. WALZE D=139,7	RODILLO TRASERO D=139,7
14	M33416611R	RULLO POSTERIORE D=139,7	REAR ROLLER D=139,7	ROULEAU ARR. D=139,7	HECK WALZE D=139,7	RODILLO TRASERO D=139,7
15	M33418611R	RULLO POSTERIORE D=139,7	REAR ROLLER D=139,7	ROULEAU ARR. D=139,7	HECK WALZE D=139,7	RODILLO TRASERO D=139,7

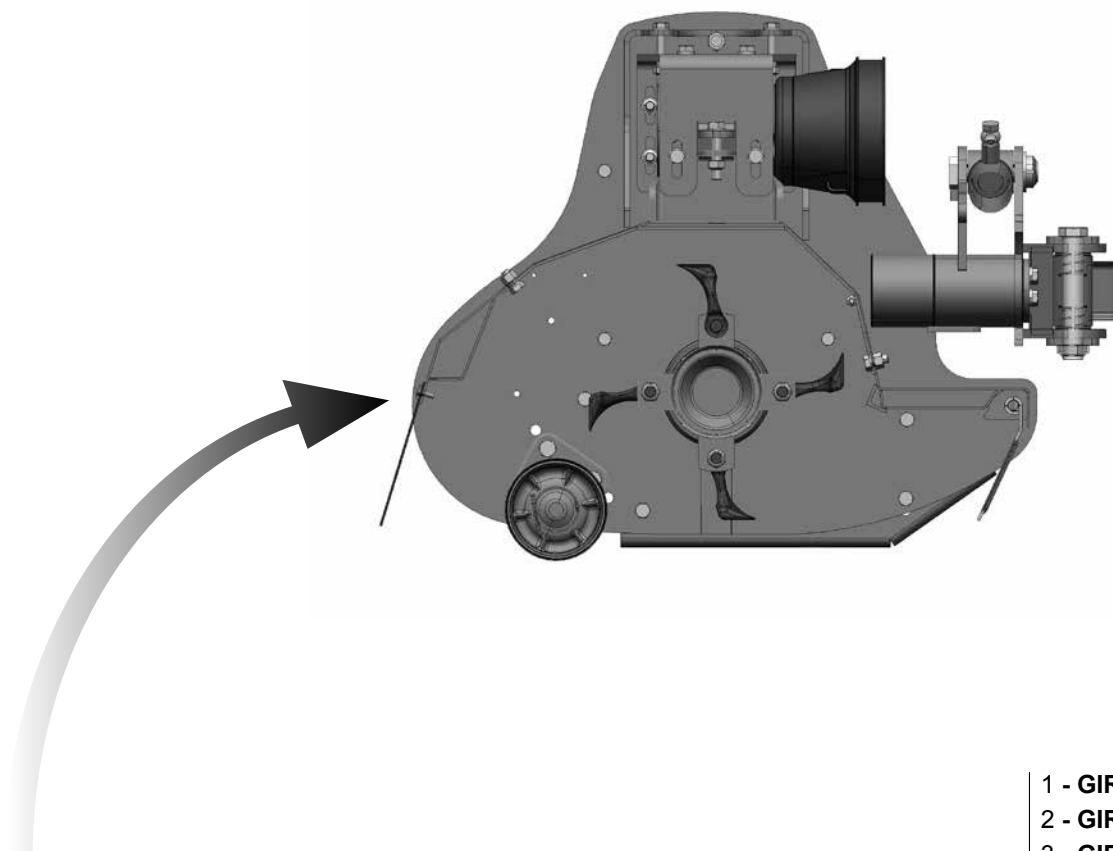

- 1 - GIRAFFA M 120
- 2 - GIRAFFA M 140
- 3 - GIRAFFA M 160
- 4 - GIRAFFA M 180

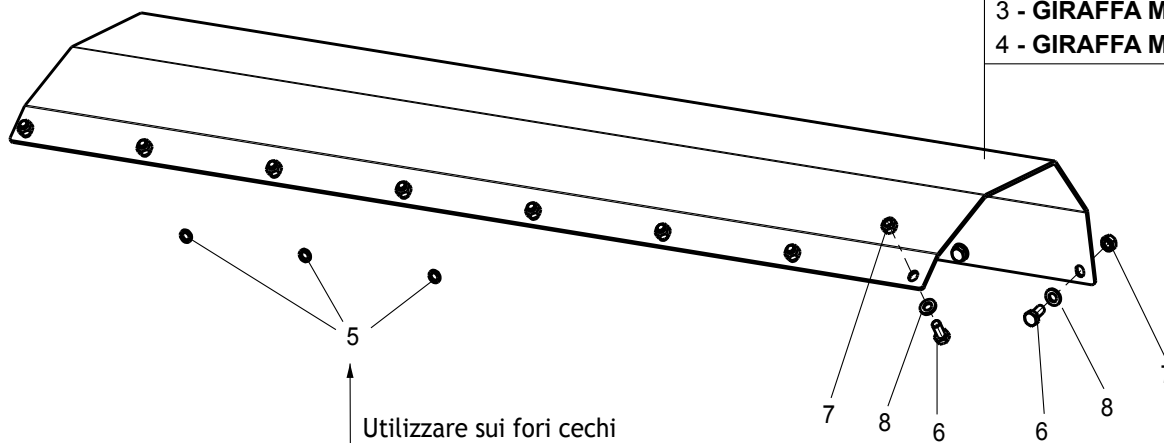

Utilizzare sui fori ciechi  
To be used on blind holes

**LAMIERA ANTIUSURA / DOUBLE SKIN FRAME**

**TAV. 060**

Pos.	Cod.	Descrizione	Description	Description	Benennung	Descripcion
1	M33412598R	LAMIERA ANTIUSURA	DOUBLE SKIN FRAME		DOUBLE SKIN RAHMEN	
2	M33414598R	LAMIERA ANTIUSURA	DOUBLE SKIN FRAME		DOPPEL SKIN RAHMEN	
3	M33416598R	LAMIERA ANTIUSURA	DOUBLE SKIN FRAME		DOUBLE SKIN RAHMEN	
4	M33418598R	LAMIERA ANTIUSURA	DOUBLE SKIN FRAME		FEDERRINGE 12,2X18 2,5 D7980ZN	ARAND. EL. 12,2X18X2,5 D7980ZN
5	F01480055R	ROS.G 12,2X 18X2,5	GROVER WASHER 12.2X18X2,5	GROVER RONDELLE 12.2X18X2,5	SCHRAUBE M12X1,25X25	TORNIL.M12X1,25X25 U5740 8.8ZN
6	F01010281R	VITE M12X1,25X25	SCREW M12X1,25X25 U5740 8.8ZN	VIS M12X1,25X25 U5740 8.8ZN	SCHEIBE BONDED AUTOCENT 3 8	ARANDELA BONDED AUTOCENT 3 8
7	F03020070R	RONDELLA AUTO. 3 8	AUTOCENT WASHER 3 8	AUTOCENT RONDELLE 3 8	SCHEIBE M12 13X24X2,5 U6592 ZN	ARAND.M12 13X 24X2,5 U6592 ZN
8	F01410076R	ROS.M1213X24X2,5	WASHER 12 13X 24X2,5	RONDELLE 12 13X 24X2,5		

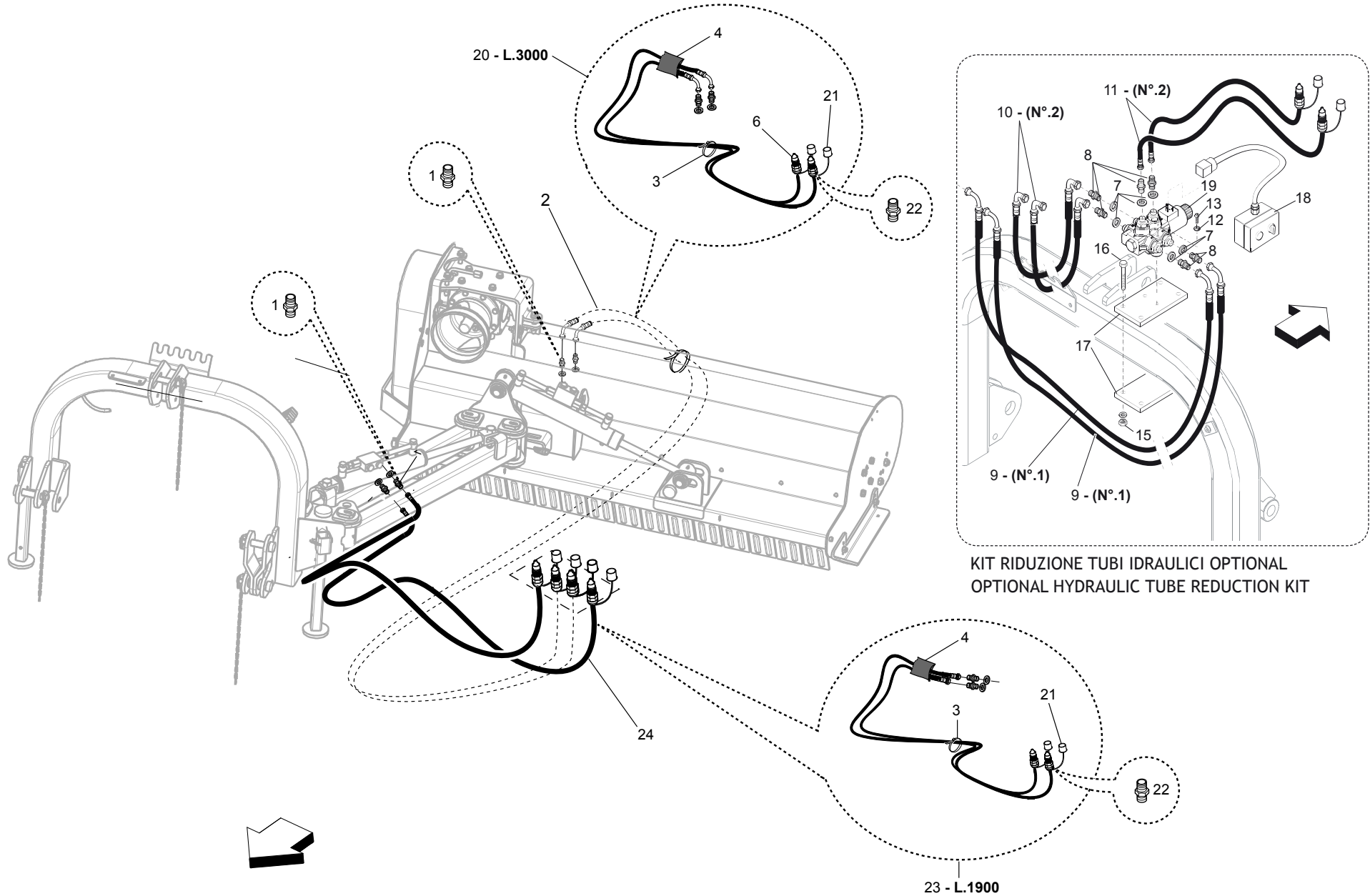



**IMPIANTO IDRAULICO - HYDRAULIC PLANT**

**TAV. 070**

Pos.	Cod.	Descrizione	Description	Description	Benennung	Description
1	F03080081R	NIPLO M3 8 SEAL ML10 ZN	NIPPLE M3 8 SEAL ML10 ZN		NIPPEL M3 8 DICHTUNG ML10 ZN	
2	F03060190R	COMP.TUBAZ.IDR.L3000 DIN24	HYDRAULIC PIPES L3000 DIN24			
3	F05150055R	FASCETTA POLYA. 3,6X200 NERA	WHITE BAND	BANDE BIANCHE	WEIBE BAND	BANDA POLYA. 3,6X200 NEGRA
4	F03100362R	GUAINA TELATA D=65 L=2350	SHEATH D=65 L=2350	GAINES D=65 L=2350	KABEL D=65 L=2350	VAINA D=65 L=2350
6	F03080090R	INNESTO RAP.MASCH.DL M16X1,5	QUICK CONNECT MALE CONE DL M16			
7	F03020070R	RONDELLA AUTO. 3 8	AUTOCENT WASHER 3 8	AUTOCENT RONDELLE 3 8	SCHEIBE BONDED AUTOCENT 3 8	ARANDELA BONDED AUTOCENT 3 8
8	F03150310R	NIPLO MM CIL-CIL 3 8-1 4 ZN	NIPPLE CYL.MALE3 8-1 4 ZN	NIPPLE MALE CYL.3 8-1 4 ZN	NIPPELZYL.3 8-1 4 ZN	NIPLE MACHO CIL.3 8-1 4 ZN
9	F03050235R	TUBO 2SN 1 4 FD1 4 F901 4 3500	HYDRAULIC TUBE R2AT 1 4	TUBE HYDRAUL. R2AT 1 4 L 3400	HYDRAUL. ROHR R2AT 1 4 L 3400	TUBO HYDRAULICO R2AT 1 4
10	F03060013R	KIT TUBAZ.IDR.X KIT GF	HYDRAULIC PIPE KIT GF		KIT TUBAZ.IDR.X KIT GF	
11	M58100890R	PREMONT.TUB.IDR.MART.LAT. GUA	HYDRAULIC TUBE	TUBE HYDRAUL.	HYDRAUL. ROHR	TUBO HYDRAULICO
12	F01480088R	ROS.G 6,4X12,4X2	GROWER WASHER D.6	GROWER RONDELLE D.6	SCHEIBE GROWER D.6	ARANDELA GROWER D.6
13	F01040068R	VITE M6X1X50	SCREW M6X1X50	VIS M6X1X50 U5931 8.8ZN	SCHRAUBE M6X1X50	TORN. M6X1X50 U5931 8.8ZN
15	F01220034R	DADO M10X1,25	NUT M10X1,25	ECROU M10X1,25 D980 8GALV.	MUTTER M10X1,25	TUER.M10X1,25 D980 8 ZB
16	F01010038R	VITE M10X1,25X140	SCREW M10X1,25X140 U5738 8.8ZN	VIS M10X1,25X140 U5738 8.8ZN	SCHRAUBE M10X1,25X140	TORN.M10X1,25X140 U5738 8.8ZN
17	M07400805R	STAFFA PORTA DEVIATORE	SUPPORT SHUNTER STIRRUP		HALTER SHUNTER STEIGBUEGEL	
18	M58100872R	COMANDO ELETTRICO 12V DC	ELECTRIC CONTROL	COMMANDE ELECTRIQUE	ELEKTRISCHER ANTRIEB	ACCIONAMIENTO ELECTRICO
19	F03151042R	DEVIATORE A 6 VIE 2 POSIZIONI	DISTRIBUTOR	DISTRIBUTEUR	VERTEILER	DISTRIBUIDOR
20	F03060186R	KIT TUB.IDR.GUAINA L3000 DIN24	KIT TUB.IDR. STE. L3000 DIN24		KIT TUB.IDR. STE. L3000 DIN24	
21	F05150325R	CAPPUC.F X INN.M RAP.1 2 ROSS	COVER CONNECT F 1 2 RED	COUVERCLE CONNEXION F 1 2 ROSE	DECKEL W 1 2 SCHNELLKUPP. ROT	PAC PROTECCION F 1 2 ROJO
22	F03080088R	NIPLO M1 2 SEAL ML10 ZN	NIPPLE M1 2 SEAL ML10 ZN		NIPPEL M1 2 DICHTUNG ML10 ZN	
23	F03060187R	KIT TUB.IDR.GUAINA L1900 DIN24	KIT TUB.IDR. STE. L1900 DIN24		KIT TUB.IDR. STE. L1900 DIN24	
24	F03060189R	COMP.TUBAZ.IDR.L1900 DIN24	HYDRAULIC PIPES L1900 DIN24			

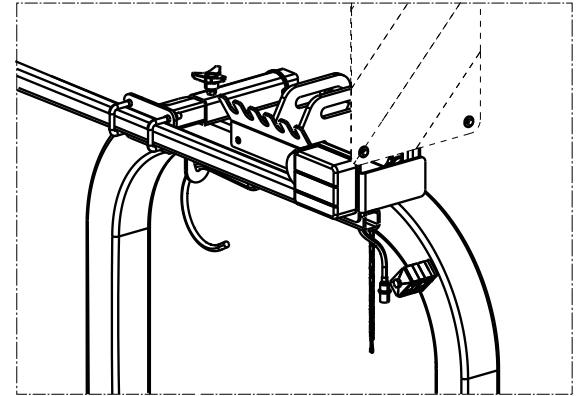
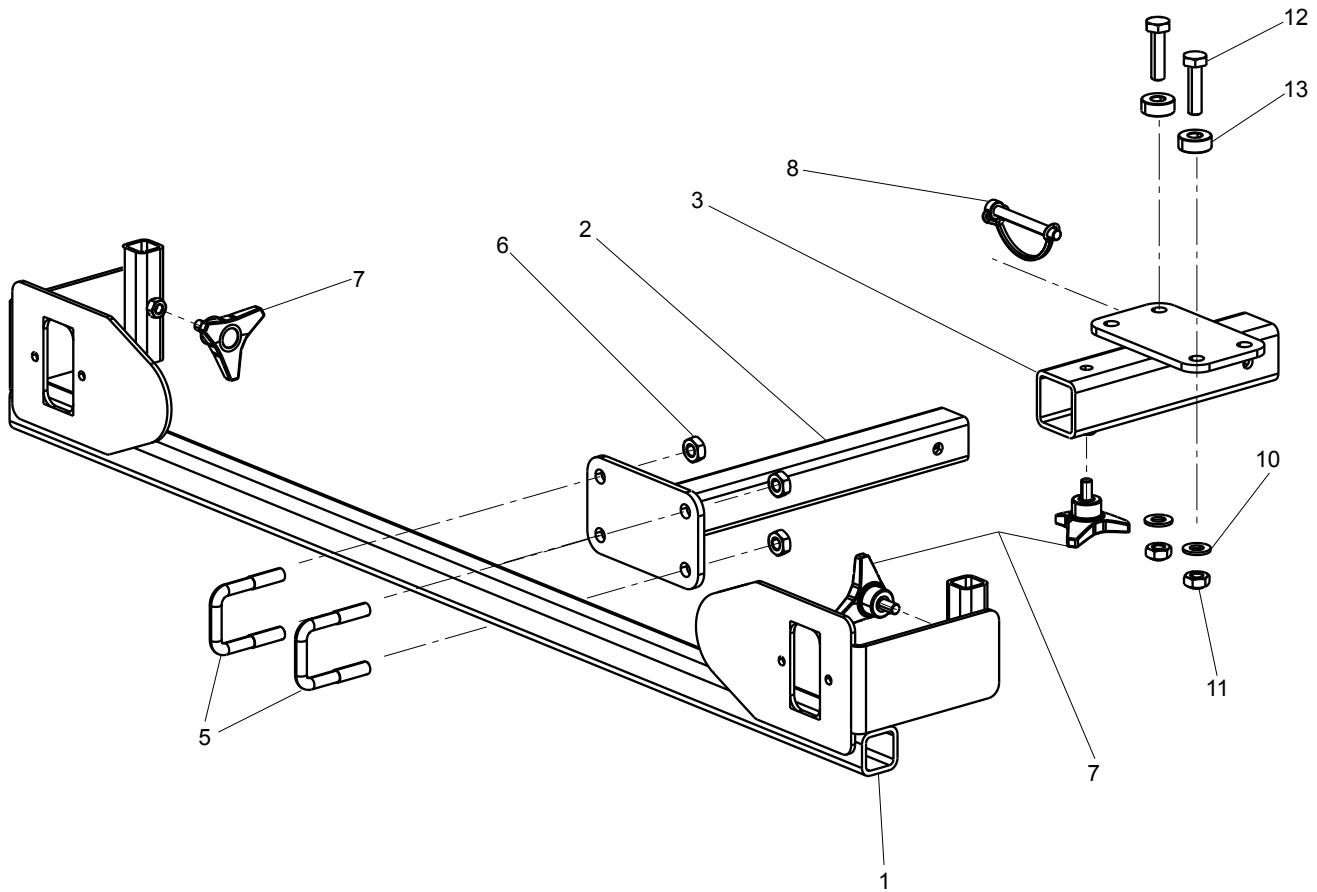

-Posizione in lavoro  
-Position in work

-Posizione in trasporto  
-Position in transport

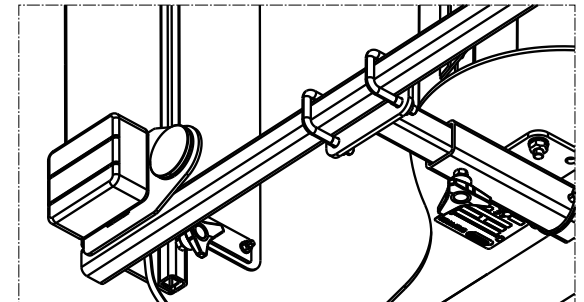
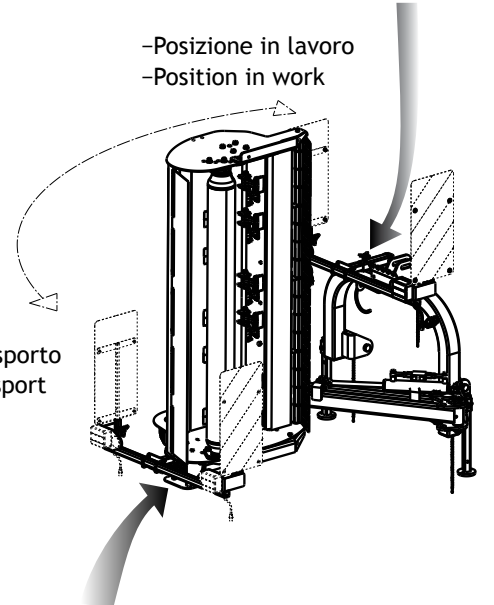

**SUPPORTI TABELLE STRADALI / ROAD KIT SUPPORTS**

**TAV. 080**

Pos.	Cod.	Descrizione	Description	Description	Benennung	Description
1	M50400758R	SUPPORTO SEGN.STRAD.BARRA LUCI	ROAD SIGN.SUPPORT			
2	M50400761R	STAFFAGGIO	BRACKET			
3	M50400764R	STAFFAGGIO	BRACKET			
5	F20110706R	CAV.Q.B=35 M=10X1,5 L=60	U BOLT Q.B=35 M=10X1,5 L=60	CAVALIER SUPPORT DISQUE SV	VERBINDUNG SCHEIBENHALTERUNG S	PERNO EN U SOP. DISCO SV
6	F01220033R	DADO M10X1,5	NUT M10X1,5	ECROU M10X1,5 D980 8GALV.	MUTTER M10X1,5	TUERCA M10X1,5 D980 8
7	F06220018R	VOLANTINO 3LOBI D.65-M8X15	3-LOBE HANDWHEEL D.65-M8X15		HANDRAD 3 BUCKEL D.65-M8X15	
8	F02200562R	SPINA SICUR.D. 8X70 ZN	SNAP PIN D.8X 70 ZN	FICHE EL. D.8X70 ZN	SCHERSTIFT D.8X 70 ZN	CLAVIJA D.8X 70 ZN
10	F01410064R	ROS.M10 10,5X 20X 2	WASHER M10 10,5X20X2	RONDELLE M10 10,5X20X2	SCHEIBE M10 10,5X20X2 U6592 ZN	ARAND.M10 10,5X 20X 2 U6592 ZN
11	F01220034R	DADO M10X1,25	NUT M10X1,25	ECROU M10X1,25 D980 8GALV.	MUTTER M10X1,25	TUER.M10X1,25 D980 8 ZB
12	F01010039R	VITE M10X1,25X40	SCREW M10X1,25X40 U5740 10.9ZD	VIS M10X1,25X40 U5740 10.9ZD	SCHRAUBE M10X1,25X40	TORN. M10X1,25X40 U5740 10.9ZD
13	M33100599R	DISTANZIALE PROTEZIONE ERP.ZPG	SPACER	ENTRETOISE	DISTANZSTUECK	DISTANCIADOR

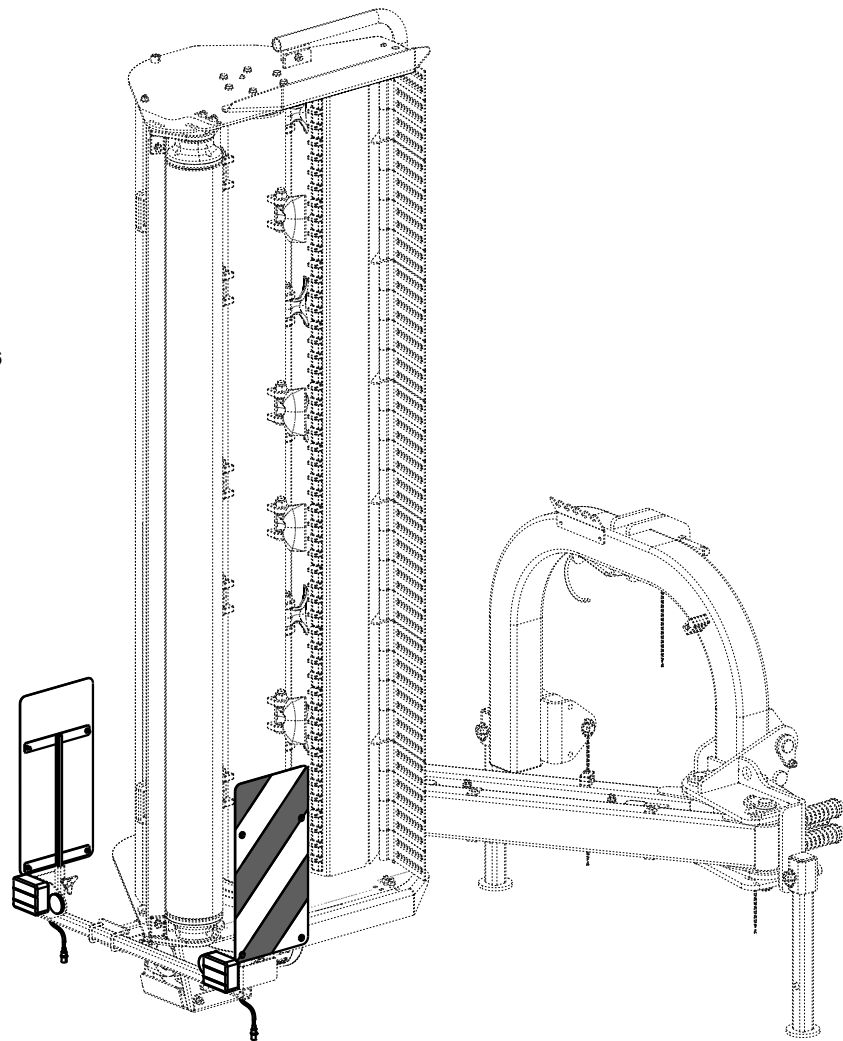
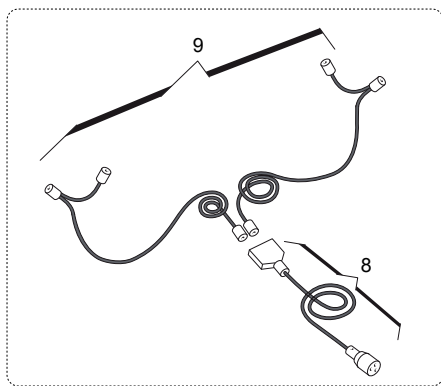
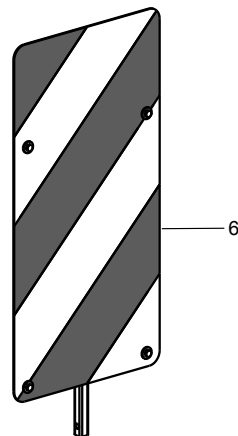
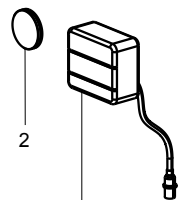
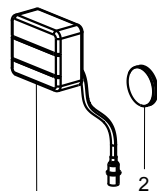
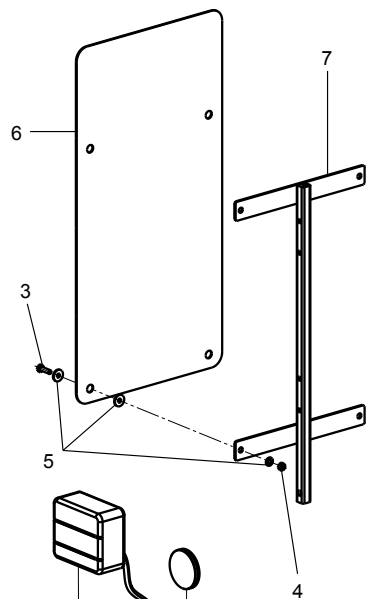

**KIT TABELLE STRADALI G99600020 - ROAD TRANSPORT KIT G99600020**

**TAV. 090**

Pos.	Cod.	Descrizione	Description	Description	Benennung	Description
1	F05010822R	KIT FANALI DX-SX CON CAVO	KIT REAR ROAD LIGHTS MOUNTED		BELEUCHTUNG INKL. KABELBAUM	
2	F05010820R	CATARIFR.TONDO D60 ROSSO	ROUND REFLECTOR D.60 RED		REFLEKTOR RUND ROT D.60MM	
3	F01020404R	VITE M6X1X20	SCREW M6X1X20 U5739 8.8ZN	VIS M6X1X20 U5739 8.8ZN	SCHRAUBE M6X1X20	TORNILLO M6X1X20 U5739 8.8ZN
4	F01220011R	DADO M6X1	NUT M6X1	CROU M6X1 D980 8ZN	MUTTER M6X1	TUERCA M6X1 D980 8 ZN
5	F01420036R	ROS.M6 6,4X 18X1,5	WASHER M6 6,4X 18X1,5	RONDELLE M6 6,4X 18X1,5	SCHEIBEN M6 6,4X18X1,5U6593 ZN	ARANDELA M6 6,4X18X1,5U6593ZN
6	F05010816R	TABELLE 2 CAR.SPORGENTI IT	WARNING BOARDS 2 IT	PANNEAU 2 SIGNALISATION IT	BRETT 2 WARNUNG IT	TABLAS 2 CAR.ADVERT. IT
7	G16612070R	TELAIO SUPP.TABELLE STRAD.	FRAME SUPPORT TABLE			
8	F05200026R	CABLAGGIO PRINCIPALE	MAIN CABLE			
9	F05200027R	CABLAGGIO ALI LUCI STRADALI	LATERAL STREET LIGHTS CABLE			

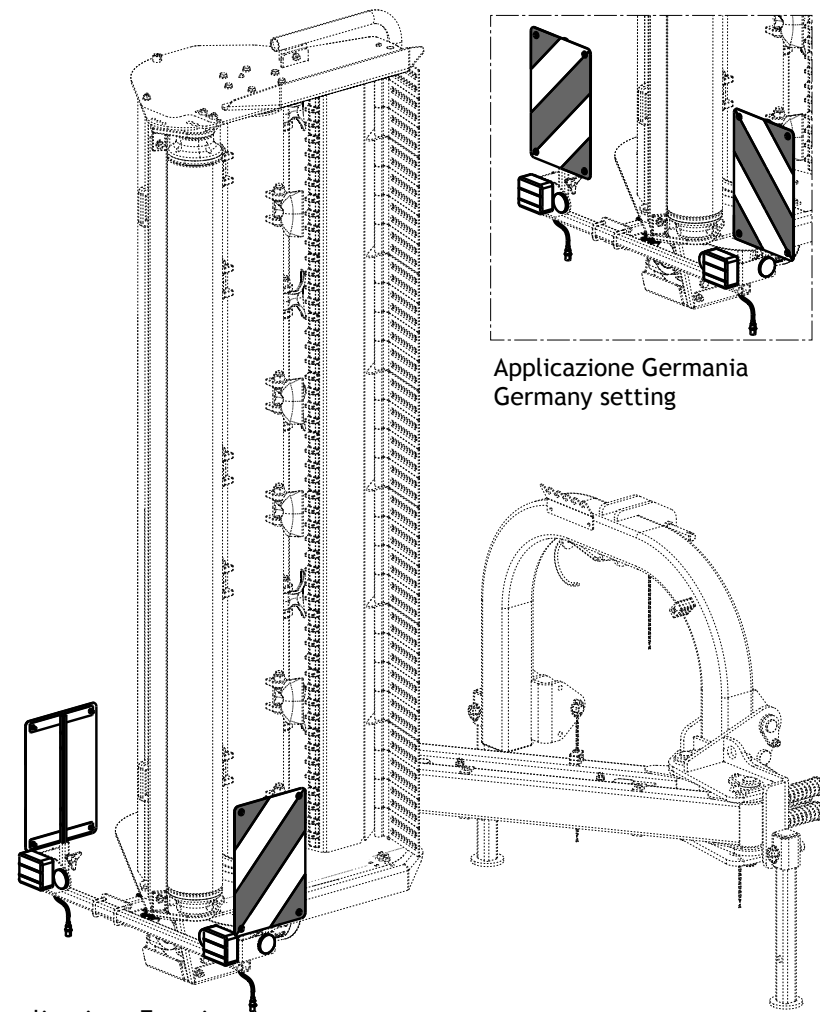
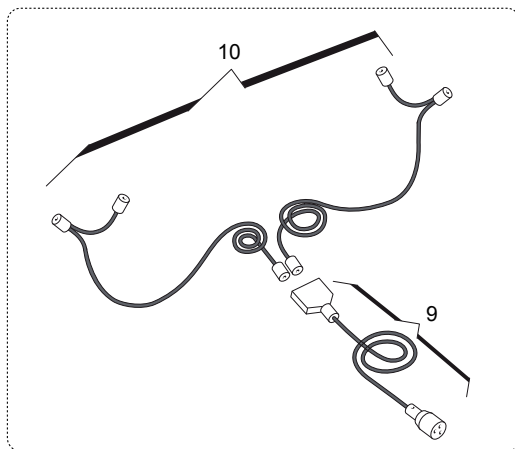
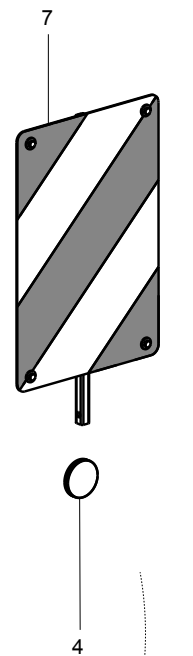
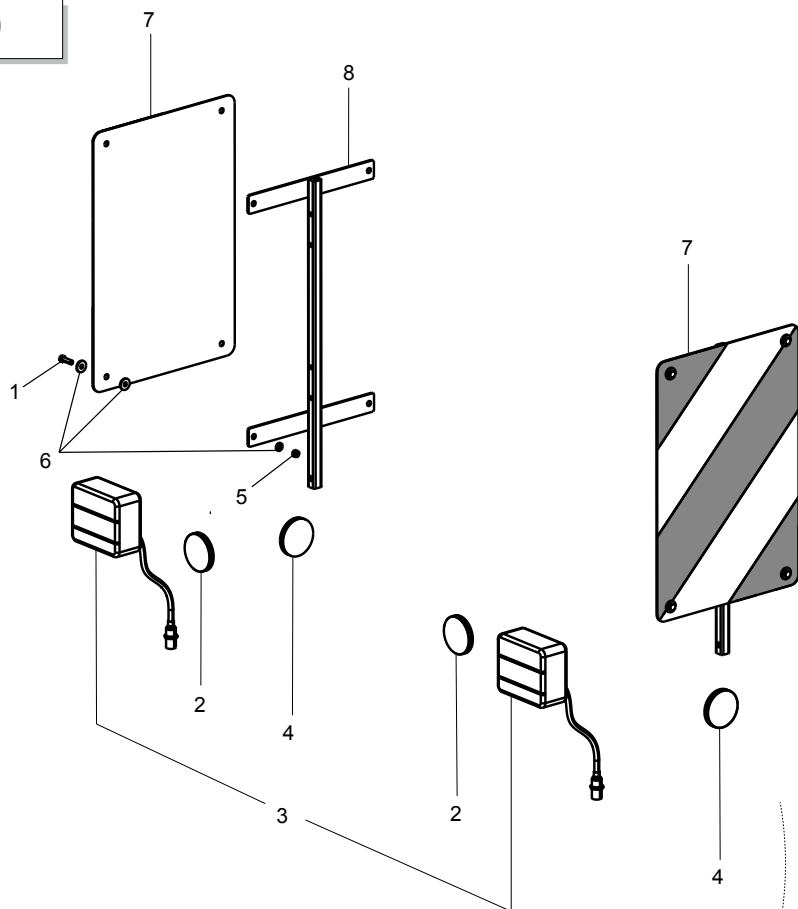

Applicazione Germania  
Germany setting

Applicazione Francia  
France setting



**KIT TABELLE STRADALI G99600021 - ROAD TRANSPORT KIT G99600021**

**TAV. 100**

Pos.	Cod.	Descrizione	Description	Description	Benennung	Descripcion
1	F01020404R	VITE M6X1X20	SCREW M6X1X20 U5739 8.8ZN	VIS M6X1X20 U5739 8.8ZN	SCHRAUBE M6X1X20	TORNILLO M6X1X20 U5739 8.8ZN
2	F05010822R	KIT FANALI DX-SX CON CAVO	KIT REAR ROAD LIGHTS MOUNTED		BELEUCHTUNG INKL. KABELBAUM	
3	F05010820R	CATARIFR.TONDO D60 ROSSO	ROUND REFLECTOR D.60 RED		REFLEKTOR RUND ROT D.60MM	
4	F05010819R	CATARIFR.TONDO D60 GIALLO	ROUND REFLECTOR D.60 YELLOW	JAUNE R FLECTEUR ROUND	RUNDREFLEKTOR GELB D60	REFLECTOR REDONDO AMARILLO
5	F01220011R	DADO M6X1	NUT M6X1	CROU M6X1 D980 8ZN	MUTTER M6X1	TUERCA M6X1 D980 8 ZN
6	F01420036R	ROS.M6 6,4X 18X1,5	WASHER M6 6,4X 18X1,5	RONDELLE M6 6,4X 18X1,5	SCHEIBEN M6 6,4X18X1,5U6593 ZN	ARANDELA M6 6,4X18X1,5U6593ZN
7	F05010817R	TABELLE 2 CAR.SPORGENTI FR-D	WARNING BOARDS 2 FR-DE	TABLEAUX 2 AVERTISSEM. FR-DE	BRETT 2 WARNUNG FR-DE	TABLAS 2 CAR.ADVERT. FR-DE
8	G16612070R	TELAIO SUPP.TABELLE STRAD.	FRAME SUPPORT TABLE			
9	F05200026R	CABLAGGIO PRINCIPALE	MAIN CABLE			
10	F05200027R	CABLAGGIO ALI LUCI STRADALI	LATERAL STREET LIGHTS CABLE			

TAV. 110

## BONDIOLI

	
7 F08011800 L=1435	GIRAFFA M

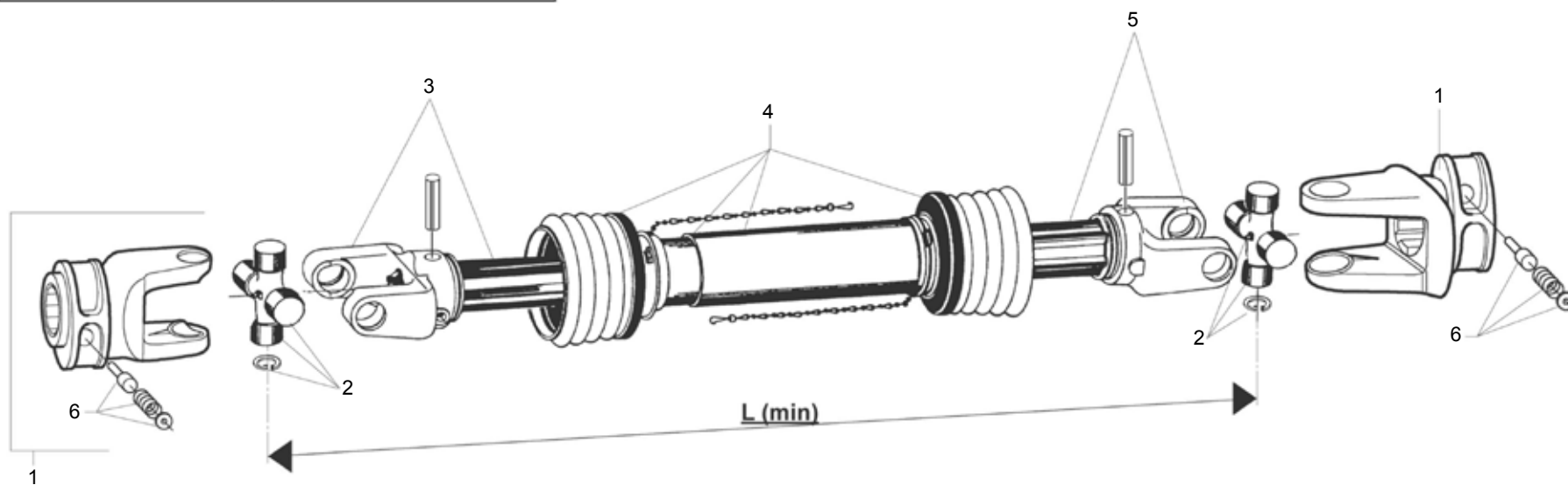



**CARDANO BONDIOLI - BONDIOLI CARDAN SHAFT**

**TAV. 110**

Pos.	Cod.	Descrizione	Description	Description	Benennung	Description
1	F08011924R	5720G0381A FORC.S6 1 3 8Z6 BO	5720G0381A BON.FORK S6 1 3 8Z6			
2	F08011925R	41205A001AR40 CROC. COMP. B5	41205A001AR40 SPIDER ASSY B5			
3	F08012155R	FORC.T.INT TUBO SPIN L. 1300	FORC.T.INT PIPE SPIN L. 1300			
4	F08012156R	PROTEZ. COMPLET. L. 1450	PROTECTION		GELENKWELLENSCHUTZ L.1450	
5	F08012154R	FORC.T.EST TUBO SPIN L. 1300	FORC.T.EST PIPE SPIN L. 1300			
6	F08011910R	403000002R10 PULS.238000061 C.	403000002R10 BUTTON 238000061	POUSSOIR COMPL.	DRUCKKNOPF KOMPL.	PULSADOR COMPL.
7	F08011800R	CAR 35 BO 38Z6 DIR L1659	PTO SHAFT 35 BO 38Z6 DIR L1660			

**USATE SEMPRE RICAMBI ORIGINALI  
ALWAYS USE ORIGINAL SPARE PARTS  
IMMER DIE ORIGINAL-ERSATZTEILE VERWENDEN  
EMPLOYEZ TOUJOURS LES PIECES DE RECHANGE ORIGINALES  
UTILIZAR SIEMPRE REPUESTOS ORIGINALES**



**Servizio Assistenza Tecnica - After Sales Service  
Servizio Ricambi - Spare Parts Service**



**maschio.com**

DEALER:



**MASCHIO GASPARDO SpA**  
**Registered Office and Production Plant**  
Via Marcello, 73 - 35011 Campodarsego (Padova) - Italy  
Tel. +39 049 9289810  
Fax +39 049 9289900  
info@maschio.com  
www.maschionet.com

**MASCHIO DEUTSCHLAND GMBH**  
Äußere Nürnberger Straße 5  
D - 91177 Thalmässing - Deutschland  
Tel. +49 (0) 9173 79000  
Fax +49 (0) 9173 790079  
dialog@maschio.de  
www.maschionet.de

**MASCHIO FRANCE Sarl**  
1 rue Denis Papin ZA  
F - 45240 La Ferte St. Aubin  
France  
Tel. +33 (0) 2.38.64.12.12  
Fax +33 (0) 2.38.64.66.79  
info@maschio.fr

**ООО МАСКИО-ГАСПАРДО РУССИЯ**  
04130, Россия,  
Волгоградская область,  
г. Волжский, ул. Пушкина, 117 «б».  
Тел.: +7 8443 203100  
факс: +7 8443 203101  
e-mail: info@maschio.ru

**MASCHIO GASPARDO SpA**  
**Production Plant**  
Via Mussons, 7 - 33075 Morsano al Tagliamento (PN) - Italy  
Tel. +39 0434 695410  
Fax +39 0434 695425  
info@gaspardo.it

**MASCHIO-GASPARDO USA Inc**  
120 North Scott Park Road  
Eldridge, IA 52748 - USA  
Ph. +1 563 2859937  
Fax +1 563 2859938  
info@maschio.us

**MASCHIO-GASPARDO ROMANIA S.R.L.**  
Strada Înfrăţirii, F.N.  
315100 Chisineu-Cris (Arad) -România  
Tel. +40 257 307030  
Fax +40 257 307040  
info@maschio.ro

**MASCHIO IBERICA S.L.**  
**MASCHIO-GASPARDO POLAND**  
**MASCHIO-GASPARDO UCRAINA**  
**GASPARDO-MASCHIO TURCHIA**  
**MASCHIO-GASPARDO CINA**  
**MASCHIO-GASPARDO INDIA**