

MASCHIO GASPARDO S.p.A.

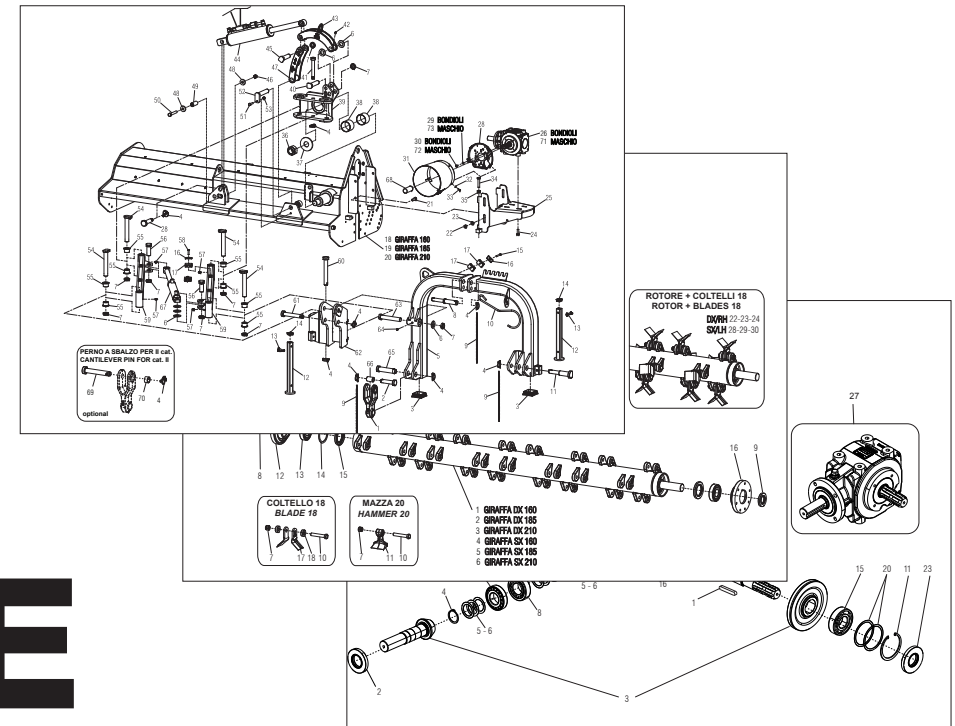

GIRAFFA-SE

Cod: F07010998 2014-02

- *) Valido per Paesi UE
- *) Valid for EU member countries
- *) Valable dans les Pays UE
- *) Gilt für EU-Mitgliedsländer
- *) Válido para Países UE

- IT** PARTI DI RICAMBIO
- EN** SPARE PARTS
- DE** ERSATZTEILE
- FR** PIÈCES DÉTACHÉES
- ES** PIEZAS DE REPUESTO

ITALIANO	ENGLISH	DEUTSCH	FRANÇAIS	ESPAÑOL
PARTI DI RICAMBIO	SPARE PARTS	ERSATZTEILE	PIECES DÉTACHÉES	RESPUESTOS
<p>Le ordinazioni delle parti di ricambio vanno fatte presso i nostri concessionari di zona e devono essere sempre corredate dalle seguenti indicazioni:</p> <ul style="list-style-type: none"> - Tipo, modello e numero di matricola dell'attrezzatura. Tali dati sono stampigliati nell'apposita targhetta di cui è dotata ogni attrezzatura. - Numero di codice della parte richiesta rilevabile dal catalogo ricambi. - Descrizione del particolare e quantità richiesta. - Numero della tavola. - Mezzo di trasporto. Nel caso questa voce non sia specificata, la Ditta Costruttrice, pur dedicando a questo servizio una particolare cura, non risponde di eventuali ritardi di spedizione dovuti a cause di forza maggiore. Le spese di trasporto si intendono sempre a carico del destinatario. La merce viaggia a rischio e pericolo del committente anche se venduta franco destino. <p>NOTA: Il termine (Dx) Destro o (Sx) Sinistro della macchina o di parti di essa, è inteso guardando la macchina dalla parte posteriore. Le eccezioni saranno indicate.</p>	<p><i>Orders must be transmitted through our area dealers and should always include the following indications:</i></p> <ul style="list-style-type: none"> - Type, model and serial number of the machine. <i>These data are punched on the data plate with which every implement is equipped.</i> - Code number of the required spare part. <i>This will be found in the spare parts catalogue.</i> - Description of the part and required quantity. - Table number. - Means of dispatch. <i>If this item is not indicated, the Manufacturer, while dedicating particular care to this service, shall not be held responsible for delays in delivery caused by cases of force majeure. Transport expenses shall always be at the consignee's charge. The goods travel at the purchaser's risk and peril even when sold ex destination.</i> <p>NOTE: <i>The symbols (Dx) right and (Sx) left, concerning the machine or single parts of it, are referred, as in the figure, to a rear view of them. Exceptions will be indicated.</i></p>	<p>Die Bestellungen müssen bei unseren Gebietshändlern aufgegeben werden. Bei der Bestellung sind stets die folgenden Angaben zu machen:</p> <ul style="list-style-type: none"> - Typ, Modell und Serien-Nummer des Geräts. Diese Daten stehen auf dem Typenschild, mit dem jedes Gerät versehen ist. - Artikel Nr. der erforderlichen Ersatzteile. Diese stehen im Ersatzteil-Katalog. - Beschreibung des Ersatzteils und die erforderliche Stückzahl. - Tafelnummer. - Versandmittel. Wenn dieser Punkt nicht spezifiziert wird, haftet die Herstellerfirma nicht für etwaigen Lieferverzug aufgrund höherer Gewalt, auch wenn er diesen Service besonders aufmerksam abwickelt. Die Frachtkosten gehen dagegen immer zu Lasten des Empfängers. Die Ware reist auf Gefahr und Risiko des Auftraggebers, auch wenn frei Haus Verkauft vereinbart worden ist. <p>N.B.: Die Merkzeichen (Dx) rechts und (Sx) links betreffen eine rückwärtige Aussicht der Maschine oder Teile von ihr (siehe Bild). Ausnahmen werden gezeigt.</p>	<p><i>Les ordres doivent être effectués auprès de nos concessionaires de zone en précisant les indications suivantes:</i></p> <ul style="list-style-type: none"> - Type, modèle et numéro de série de la machine. <i>Ces données sont gravées sur la plaque d'identification de chaque outil.</i> - Numéro de code de la pièce détachée indiqué sur le catalogue des pièces détachées. - Description de la pièce et quantité requise. - Numéro de plan. - Moyen d'expédition. <i>Si cette rubrique n'est pas indiquée, le Constructeur, bien que soucieux de ce service, ne répond pas des retards d'expédition pour des causes de force majeure. Les frais de transport sont toujours à la charge du destinataire. La marchandise voyage aux risques et périls de l'acheteur même si vendue franco de port.</i> <p>N.B.: <i>Les références (Dx) droit et (Sx) gauche de la machine ou des parties de la même, est entendue, comme de la figure, en regardant la machine de derriere dans le sens de marche.</i></p>	<p>Los pedidos han de efectuarse en nuestros concesionarios de zona y deben incluir siempre las siguientes indicaciones:</p> <ul style="list-style-type: none"> - Tipo, modelo y número de matrícula del equipo. Dichos datos están impresos en la relativa placa presente en el equipo. - Número de código de la parte requerida presente en el catálogo respuestas. - Descripción de la pieza y cantidad requerida. - Numero de ilustración. - Medio de transporte. En caso que este ítem no esté especificado, el Fabricante, aún prestando la debidas consideraciones para este aspecto, no responde por eventuales retardos de env'o debidos a causas de fuerza mayor. Los gastos de transporte se consideraran siempre a cargo del destinatario. La mercadería viaja bajo riesgo y peligro del comprador, incluso cuando se vende franco destino. <p>N.B.: La referencia (Dx) derecha o (Sx) izquierda de la máquina o de sus componentes, se entiende, como en la figura, mirando la máquina por la parte trasera. Se indicarán las excepciones.</p>

INDICE

<i>N° Tavola</i>	<i>Descrizione</i>	<i>Pagina</i>
TAV. 010	Telaio destro e terzo punto.....	4
TAV. 020	Telaio sinistro e terzo punto	8
TAV. 030	Trasmissione.....	12
TAV. 040	Rullo ed optionals	14
TAV. 050	Rotore	16
TAV. 060	Rotore multiaggressivo	18
TAV. 070	Moltiplicatore 540 rpm - Maschio per versione destra	20
TAV. 080	Moltiplicatore 540 rpm - Bondioli per versione destra	22
TAV. 090	Moltiplicatore 540 rpm - Maschio per versione sinistra	24
TAV. 100	Moltiplicatore 540 rpm - Bondioli per versione sinistra	26
TAV. 110	Impianto idraulico.....	28
TAV. 120	Cardano Walterscheid.....	30
TAV. 130	Cardano Bondioli	32
TAV. 140	Cardano omocinetico Walterscheid	34

INDEX

<i>N° Table</i>	<i>Description</i>	<i>Page</i>
TAV. 010	Right frame and 3rd point hitch.....	4
TAV. 020	Left frame and 3rd point hitch	8
TAV. 030	Transmission	12
TAV. 040	Roller and optionals	14
TAV. 050	Rotor	16
TAV. 060	Multiaggressiv rotor.....	18
TAV. 070	Gearbox 540 rpm - Maschio for right version.....	20
TAV. 080	Gearbox 540 rpm - Bondioli for right version	22
TAV. 090	Gearbox 540 rpm - Maschio for left version.....	24
TAV. 100	Gearbox 540 rpm - Bondioli for left version	26
TAV. 110	Hydraulic plant	28
TAV. 120	Walterscheid cardan shaft.....	30
TAV. 130	Bondioli cardan shaft	32
TAV. 140	Walterscheid constant velocity PTO shaft.....	34

**TELAIO DESTRO
RIGHT HAND FRAME**

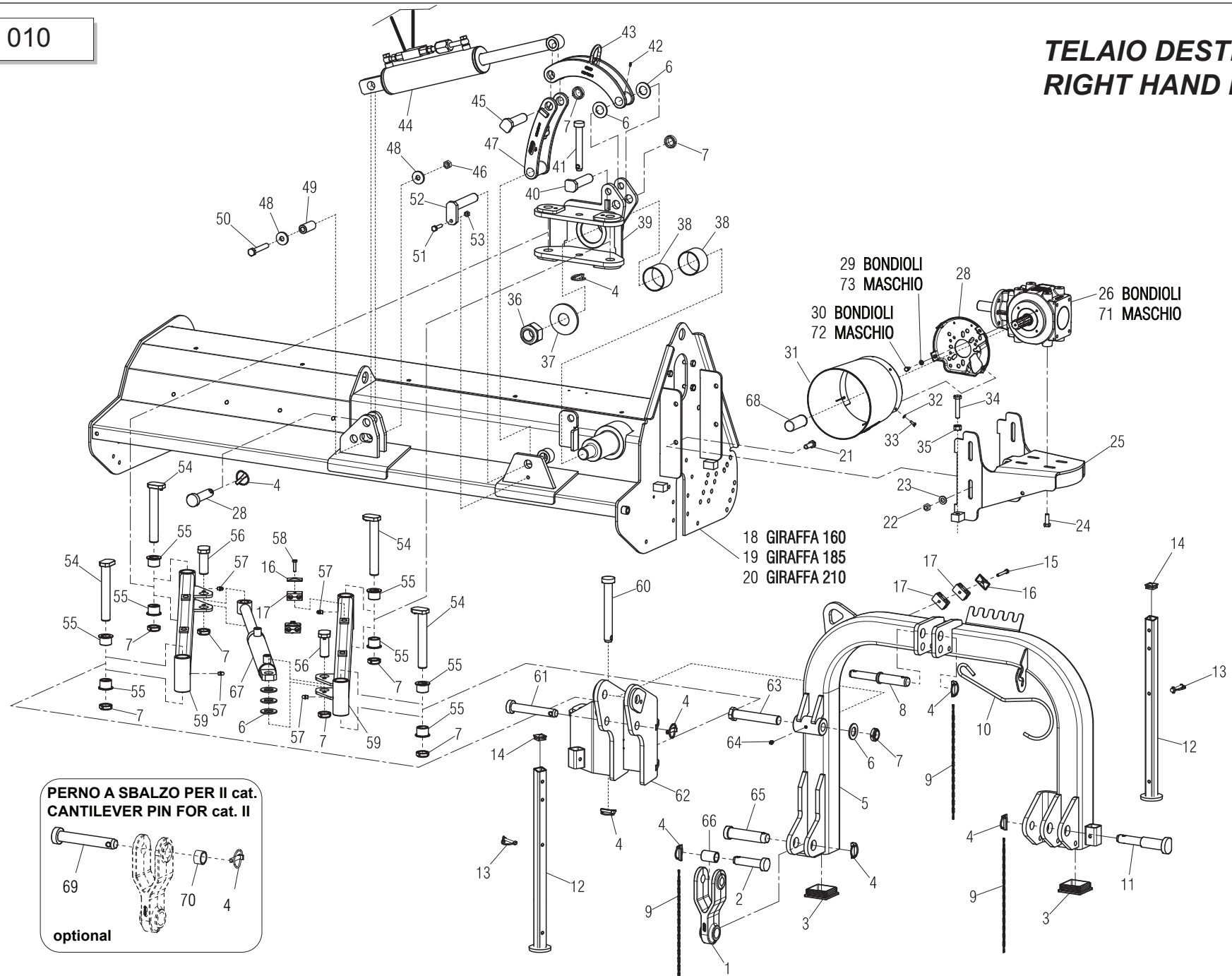

TELAIO DESTRO E TERZO PUNTO / RIGHT FRAME AND 3rd POINT HITCH

TAV. 010

Pos.	Cod.	Descrizione	Description	Benennung	Description	Description
1	M30400902	BIELLA ATT.BARRE IN CERA PERSA	BAR LINKAGE CONNECTION ROD	BIELLE ATTELAGE BARRE	PLEUELSTANGE VERB. SCHUTZ HOLM	BIELA ATAQUE BARRA
2	F20100074	PERNO D28 L109 C43 SPINA 3°P.	PIN FOR BAR LINKAGE	GOUJON ATTELAGE BARRE	VERB.BOLZEN SCHUTZ HOLM	PERNO ATAQUE BARRA
3	F03150773	TAPPO*X TUBO 90X 90 SP.2-5	TUBE CAP 90X 90 SP.2-5	BOUCHON 90X 90 SP.2-5	ROHRKOPFSTOPFEN 90X 90 SP.2-5	TAPON 90X 90 SP.2-5
4	F02200529	SPINA SCATTO D.11 ZN	SNAP PIN D.11	FICHE A DETENTE D.11	EINRASTSTIFT D.11	CLAVIJA DE MUELLE D.11
5	M30400900	COMP.TERZO PUNTO GIRAFFA	COMPL. 3RD POINT GIRAFFA	3EME POINT	3. PUNKT	TERCER PUNTO
6	F01410168	ROS.M30 31X 56X 4 U6592 ZN	WASHER M30 31X56X4 U6592 ZN	RONDELLA M30 31X56X4 U6592 ZN	SCHRAUBE M30 31X56X4 U6592 ZN	ARANDELLA M30 31X56X4 U6592 ZN
7	F02010111	GHIERA AU.GUP M30X1,5 T.4H ZN	SELF LOCKING NUT M30X1,5	COLLIER AUTOBL. M30X1,5	SELBSTSP. NUTMUTTER M30X1,5	VIROLA AUTOBL. M30X1,5
8	F20100130	PERNO ATTACCO TIRANTE 2°C+3°ZN	STAY ROD LINKAGE PIN	ROHRKOPFSTOPFEN	BOUCHON	TAPON
9	M58100930	CATENELLA L=476	ASSEMBLY CHAIN DMP L=476	CHAINE L=476	KETTE L=476	CADENA L=476
10	F20120400	GANCIO SOSTEGNO CARDANO	SHAFT HOOK SUPPORT	SUPPORT CARDAN	GELENKWELLE - HACKEN	SOPORTE CARDAN
11	M21400563	PERNO ATTACCO BARRA.2°-3° C.	PIN FOR BAR LINKAGE	GOUJON ATTELAGE BARRE	VERB.BOLZEN SCHUTZ HOLM	PERNO ATAQUE BARRA
12	M06700513	COMPOSTO PIEDINO L=670	SUPPORT FEET	STANDER	SUPPORT	SOPORTE
13	F02200562	SPINA SICUR. D. 8X70 ZN	SNAP PIN D.8X 70 ZN	FICHE EL. D.8X70 ZN	SCHERSTIFT D.8X 70 ZN	CLAVIJA D.8X 70 ZN
14	F05100025	TAPPO AD ALETTE 35X35 PLT NERO	PLUG	BOUCHON FERMETURE	VERSCHLUSSPFROPFEN	TAPONCLAUSURA
15	F01020077	VITE M 8X1,25X60 U5737 8.8 ZN	BOLT M8X1,25X60 U5737 8.8 ZN	VIS M8X1,25X60 U5737 8.8 ZN	SCHRA. M8X1,25X60 U5737 8.8 ZN	TORN. M8X1,25X60 U5737 8.8 ZN
16	F03150993	PIATTO X COLLARE SUPERIORE ZN	PLATE	PLAT	PLATTE	PLATO
17	F03150992	COPPIA COLLARI X TUBO D.16	DOUBLE SUPPORT	SUPPORT DOUBLE	DOPPELHALTER	SOPORTE DOBLE
18	M30416564	COMP.TELAIO SCAT.EST.GF 160	FRAME GF 160SE	CHASSIS GF 160SE	RAHMEN GF 160SE	TELAR GF 160SE
19	M30419564	COMP.TELAIO SCAT.EST.GF 190	FRAME GF 190SE	CHASSIS GF 190SE	RAHMEN GF 190SE	TELAR GF 190SE
20	M30421564	COMP.TELAIO SCAT.EST.GF 210	FRAME GF 210SE	CHASSIS GF 210SE	RAHMEN GF 210SE	TELAR GF 210SE
21	F01010318	VITE M14X 1,5X40 U5740 8.8 ZN	BOLT M 14X1,5X40	VIS M 14X1,5X40	SCHRAUBE M 14X1,5X40	TORNILLO M 14X1,5X40
22	F01220059	DADO M14X 1,5 D980 8 ZN	NUT M14X 1,5 D980 8 ZB	ECROU M14X 1,5 D980 8 ZB	MUTTER M14X 1,5 D980 8 ZB	TUERCA M14X 1,5 D980 8 ZB
23	F01410088	ROS.M14 15X 28X2,5 U6592 ZN	WAS.M14 15X 28X2,5 U6592 ZB	RON.M14 15X 28X2,5 U6592 ZB	SCH.M14 15X 28X2,5 U6592 ZB	ARA.M14 15X 28X2,5 U6592 ZB
24	F01010288	VITE M12X1,25X35 U5740 8.8 ZN	BOLT M12X1,25X35 U5740 8.8 ZN	VIS M12X1,25X35 U5740 8.8 ZN	SCHR.M12X1,25X35 U5740 8.8 ZN	TORN.M12X1,25X35 U5740 8.8 ZN
25	M30400528	COMP. ATTACCO SCATOLA GF	BRACKET	PLATTE	PLAQUETTE	PLAQUITA
26	M30400205	SCATOLA MULTIPL.540 BONDIOLI	COMPLETE GEARBOX	BOITE DE VITESSE	WECHSELGETRIEBE	CAJA CAMBIO COMPLETA
28	M37100106	ATTACCO PROTEZIONE	PROTECTION SUPPORT	SUPPORT PROTECTION CARDAN	GELENKWELLENSCHUTZ HALTER	SOPORTE PROTECCION CARDANICO
29	F01410051	ROS.M8 8,4X 17X1,6 U6592 ZN	WASHER M8 8,4X17X1,6 U6592 ZN	RONDEL. M8 8,4X17X1,6 U6592 ZN	SCHIEBE M8 8,4X17X1,6 U6592 ZN	ARANDELA M8 8,4X17X1,6 U6592 ZN
30	F01020432	VITE M 8X1,25X16 U5739 8.8 ZN	BOLT M8X 1.25X16 U5739 8.8 ZN	VIS M 8X16	SCHRAUBE M 8X16	TORNILLO M 8X16
31	M68100106	PROTEZIONE CARDANO	CARDAN PROTECTION	PROTECTION CARDAN	GELENKWELLENSCHUTZ	PROTECCION CARDANICO
32	F01410037	ROS.M6 6,4X12,5X1,6 U6592 ZN	PLANE WASHER D.6	RONDELLE D.6	SCHIEBE D.6	ARANDELA D.6
33	F01020403	VITE M6X1X16 U5739 8.8 ZN	BOLT M6X1X16 U5739 8.8 ZN	VIS M6X1X16 U5739 8.8 ZN	SCHRAUBE M6X1X16 U5739 8.8 ZN	TORNILLO M6X1X16 U5739 8.8 ZN
34	F01010323	VITE M14X1,5 X70 U5740 8.8 ZN	BOLT M14X1,5X70 U5740 8.8 ZN	VIS M 14X1,5X70	SCHRAUBE M 14X1,5X70	TORNILLO M 14X1,5X70
35	F01200089	DADO M14X 1,5 U5587 6S ZN	NUT M14X 1,5 U5581 6S ZB	ECROU M14X 1,5 U5587 6S ZB	MUTTER M14X 1,5 U5587 6S ZB	TUERCA M14X 1,5 U5587 6S ZB
36	F01230179	DADO M42X 3 D982 8 ZN	SELF LOCKING NUT M42X3	ECROU AUTOBL. M42X3	SELBSTSPERR.MUTTER M42X3	DADO AUTOBL. M42X3
37	M07400525	ROSETTA DI BLOCCAGGIO	PLANE WASHER	RONDELLE	SCHIEBE	ARANDELA
38	F04100105	BOCCOLA D=85 D=80 L=60 AUTOLUB	BUSHING D=85 D=80 L=60	BOUCLE D=85 D=80 L=60	BUECHSE D=85 D=80 L=60	ARANDELA D=85 D=80 L=60
39	M07400709	GIUNTO MOVIMENTAZIONE	JOINT	JOINT	VERBINDUNG	JUNTA
40	M07400592	COMP.PERNO D=30 L=119	PIN	GOUJON	STIFT	PERNO

----- CONTINUA A PAGINA SEGUENTE -----

----- CONTINUED ON NEXT PAGE -----

**TELAIO DESTRO
RIGHT HAND FRAME**

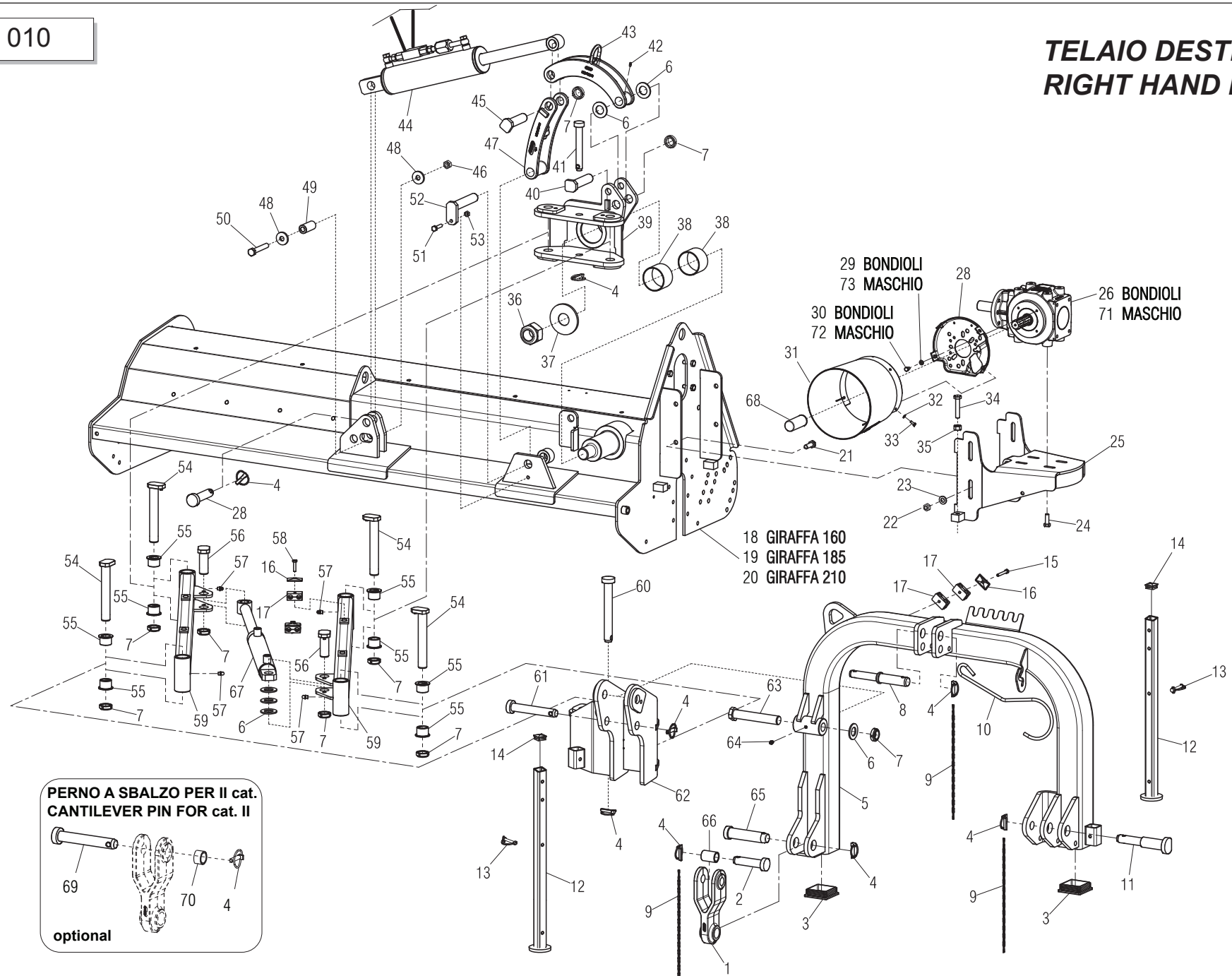

TELAIO DESTRO E TERZO PUNTO / RIGHT FRAME AND 3rd POINT HITCH

TAV. 010

Pos.	Cod.	Descrizione	Description	Benennung	Description	Description
<p>----- CONTINUA DA PAGINA PRECEDENTE ----- ----- CONTINUED FROM PRECEDING PAGE -----</p>						
41	F20100115	PERNO D22 L144 ZN	GASPARDO PIN 22X144 ZN	GOUPILLE GASPARDO 22X144 ZN	GASPARDO-STIFT 22X144 ZN	PASADOR GASPARDO 22X144 ZN
42	F01100011	ING.M 6X1 7663-A 9SMNPB28 ZN	GREASE NIPPLE M6X1 7663-A ZN	GRAISS. A BILLE M6X1 7663A ZN	SCHMIERBUECHE M6X1 7663-A ZN	ENGRAS. DE ESFERAS M6X1 7663-A
43	M30400546	BIELLA SUPERIORE IN CERA PERSA	UPPER CONNECTION ROD	BIELLE ATTELAGE	PLEUELSTANGE	BIELA ATAQUE
44	M30400530	MARTINETTO ID.A=80 C=273 L=566	CYLINDER A=80 C=273 L=566	MANIVELLE HYDRAULIQUE	HYDRAUL.SPINDELVERSTELLUNG	GATO HYDRAULICO
45	M07400598	COMP.PERNO D=30 L=109	PIN D=30 L=109	GOUJON D=30 L=109	STIFT D=30 L=109	PERNO D=30 L=109
46	F01220070	DADO M16X 1,5 D980 8 ZN	NUT M16X 1,5 D980 8 ZB	ECRO.M16X 1,5 D980 8 ZB	MUTT.M16X 1,5 D980 8 ZB	TUER.M16X 1,5 D980 8 ZB
47	M06700515	BIELLA INFERIORE SENZA FERMO	CONNECTION ROD	PLEUEL	BIELLE	VARILLA
48	F01500023	ROS. 17 X45X6 D6340 C50 ZD	ELASTIC DISK	DISQUE ELASTIQUE	ELASTISCHE SCHEIBE	DISCO ELASTICO
49	M50400556	DISTANZIALE D=30 D=20 L=65	SPACER D=30 D=20 L=65	ENTRETOISE D=30 D=30 L=65	DISTANZST.D=30 D=20 L=65	DISTANCIAD.D=30 D=20 L=65
50	F01010124	VIT.M16X 1,5X100 U5738 8.8 ZN	BOLT M16X1,5X100	VIS M16X1,5X100	SCHRAUBE M16X1,5X100	TORNILLO M16X1,5X100
51	F01010026	VITE M10X1,25X40 U5738 8.8 ZN	BOLT M 10X1,25X40	VIS M 10X1,25X40	SCHRAUBE M 10X1,25X40	TORNILLO M 10X1,25X40
52	M07400596	COMP.PERNO D=30 L=150	PIN	GOUJON	STIFT	PERNO
53	F01220034	DADO M10X1,25 D980 8 ZN	NUT M10X1,25 D980 8 ZB	ECRO.M10X1,25 D980 8 ZB	MUTT.M10X1,25 D980 8 ZB	TUER.M10X1,25 D980 8 ZB
54	M07400726	PERNO D=30 L= 199	PIN D=30 L= 199	GOUJON D=30 L= 199	BOLZEN D=30 L= 199	PERNO D=30 L= 199
55	M07400929	BOCCOLA D=30 D=40 L=30	BUSHING D=30 D=40 L=30	BOUCLE D=30 D=40 L=30	BUECHSE D=30 D=40 L=30	ARANDELA D=30 D=40 L=30
56	M06700512	PERNO D=30 L= 78	PIN D=30 L= 78	GOUJON D=30 L= 78	BOLZEN D=30 L= 78	PERNO D=30 L= 78
57	F01100063	ING.M10X1 7663-C 9SMNPB28 ZN	GREASE NIPPLE	SCHMIERBUECHSE	GRAISSEUR	ENGRASADOR
58	F01020449	VITE M 8X1,25X35 U5739 8.8 ZN	BOLT M8X 1.25X35 U5739 8.8 ZN	VIS M 8X35	SCHRAUBE M 8X35	TORNILLO M 8X35
59	M30400555	COMP. PARALLELOGRAMMA UNIFICAT	ARM	ARM	BRAS	BRAZO
60	F20100077	PERNO D=28 L=194 ZN	PIN D=28 L=200	GOUJON D=28 L=200	STIFT D=28 L=200	PERNO D=28 L=200
61	F20100076	PERNO D28 L154 C40 ZN	BOLT D28 L154 C40 ZN	BOULON D28 L154 C40 ZN	BOLZEN D28 L154 C40 ZN	PERNO D28 L154 C40 ZN
62	M30400542	COMPOSTO ATTACCO 3°PUNTO DX	COUPLING	KUPPLUNG	FIXATION	CONEXIN
63	M07400589	COMP.PERNO D=30 L=179	PIN	GOUJON	STIFT	PERNO
64	F01100061	ING.M10X1 7663-A 9SMNPB28 ZN	GREASE NIPPLE M10X1 7663-A ZN	GRAISSEUR M10X1 7663-A ZN	SCHMIERBUECHSE M10X1 7663-A ZN	ENGRASADOR M10X1 7663-A ZN
65	F20100141	PERNO D36 L128 C43 ZN	PIN D36 L128 C43 ZN	BOULON D36 L128 C43 ZN	BOLTZEN D36 L128 C43 ZN	PERNO D36 L128 C43 ZN
66	M68100932	BUSSOLA	BUSHING	BOUSSOLE	BUECHSE	BRUJULA
67	M07400588	COMP. MART.IDR.A=50 C=314 L616	CYLINDER A=50 C=314 L=616	VERIN	SPINDELVERSTELLUNGSTEIL	MARTINETE
68	M38100146	MANICOTTO PROTEZIONE PDF 1"3/8	P.T.O. PROTECTION	MANCHON DE PROTECTION P.T.O.	ZAPFWELLENSCHUTZ P.T.O.	MANGUITO PROTECCION P.T.O.
69	F20100138	PERNO D28 L154 C43 ZN	PIN D28 L154 C43 ZN	BOLTZEN D25 L154 C43 ZN	BOULON D28 L154 C43 ZN	PERNO D28 L154 C43 ZN
70	M36200944	DISTANZIALE MARTINETTO	SPACER	DISTANZSTUECK	ENTRETOISE	DISTANCIADOR
71	M30400201	MOLTIPLIC. GF.SI.SX-SE.DX MASCHIO	GEARBOX	WECHSELGETRIEBEGEHAUSE	BOITE DE VITESSE	CAJA CAMBIO
72	F01020468	VITE M10X1,5 X16 U5739 8.8 ZN	BOLT M10X1,5 X 16	DUEBEL M10X1,5 X 16	RONDELLE M10X1,5 X 16	TORNILLO M10X1,5 X 16
73	F01410064	ROS.M10 10,5X 20X 2 U6592 ZN	WASHER M10 10,5X20X2 U6592 ZN	SCHEIBE M10 10,5X20X2 U6592 ZN	RONDELL.M10 10,5X20X2 U6592 ZN	ARAND. M10 10,5X20X2 U6592 ZN

**TELAIO SINISTRO
LEFT HAND FRAME**

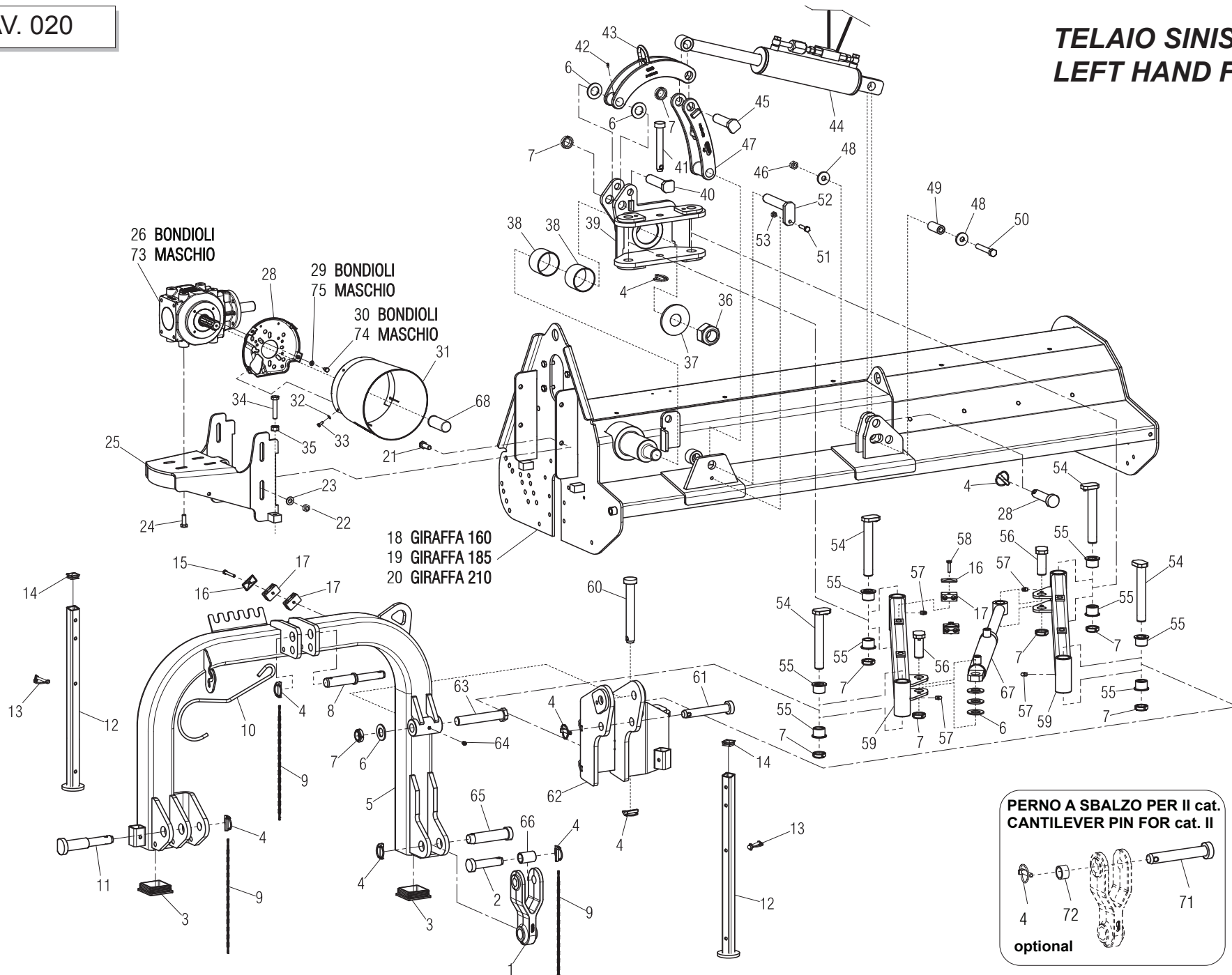

TELAIO SINISTRO E TERZO PUNTO / LEFT FRAME AND 3rd POINT HITCH

TAV. 020

Pos.	Cod.	Descrizione	Description	Benennung	Description	Description
1	M30400902	BIELLA ATT.BARRE IN CERA PERSA	BAR LINKAGE CONNECTION ROD	BIELLE ATTELAGE BARRE	PLEUELSTANGE VERB. SCHUTZ HOLM	BIELA ATAQUE BARRA
2	F20100074	PERNO D28 L109 C43 SPINA 3°P.	PIN FOR BAR LINKAGE	GOUJON ATTELAGE BARRE	VERB.BOLZEN SCHUTZ HOLM	PERNO ATAQUE BARRA
3	F03150773	TAPPO*X TUBO 90X 90 SP.2-5	TUBE CAP 90X 90 SP.2-5	BOUCHON 90X 90 SP.2-5	ROHRKOPFSTOPFEN 90X 90 SP.2-5	TAPON 90X 90 SP.2-5
4	F02200529	SPINA SCATTO D.11 ZN	SNAP PIN D.11	FICHE A DETENTE D.11	EINRASTSTIFT D.11	CLAVIJA DE MUELLE D.11
5	M06700517	COMP.TERZO PUNTO GIRAFFA SX	COMPL. 3RD POINT GIRAFFA 07	3. PUNKT	3EME POINT	TERCER PUNTO
6	F01410168	ROS.M30 31X 56X 4 U6592 ZN	WASHER M30 31X56X4 U6592 ZN	RONDELLA M30 31X56X4 U6592 ZN	SCHRAUBE M30 31X56X4 U6592 ZN	ARANDELLA M30 31X56X4 U6592 ZN
7	F02010111	GHIERA AU.GUP M30X1,5 T.4H ZN	SELF LOCKING NUT M30X1,5	COLLIER AUTOBL. M30X1,5	SELBSTSP. NUTMUTTER M30X1,5	VIROLA AUTOBL. M30X1,5
8	F20100130	PERNO ATTACCO TIRANTE 2°C+3°ZN	STAY ROD LINKAGE PIN	ROHRKOPFSTOPFEN	BOUCHON	TAPON
9	M58100930	CATENELLA L=476	ASSEMBLY CHAIN DMP L=476	CHAINE L=476	KETTE L=476	CADENA L=476
10	F20120400	GANCIO SOSTEGNO CARDANO	SHAFT HOOK SUPPORT	SUPPORT CARDAN	GELENKWELLE - HACKEN	SOPORTE CARDAN
11	M21400563	PERNO ATTACCO BARRA.2°-3° C.	PIN FOR BAR LINKAGE	GOUJON ATTELAGE BARRE	VERB.BOLZEN SCHUTZ HOLM	PERNO ATAQUE BARRA
12	M06700513	COMPOSTO PIEDINO L=670	SUPPORT FEET	STANDER	SUPPORT	SOPORTE
13	F02200562	SPINA SICUR. D. 8X70 ZN	SNAP PIN D.8X 70 ZN	FICHE EL. D.8X70 ZN	SCHERSTIFT D.8X 70 ZN	CLAVIJA D.8X 70 ZN
14	F05100025	TAPPO AD ALETTE 35X35 PLT NERO	PLUG	BOUCHON FERMETURE	VERSCHLUSSPFROPFEN	TAPONCLAUSURA
15	F01020077	VITE M 8X1,25X60 U5737 8.8 ZN	BOLT M8X1,25X60 U5737 8.8 ZN	VIS M8X1,25X60 U5737 8.8 ZN	SCHRA. M8X1,25X60 U5737 8.8 ZN	TORN. M8X1,25X60 U5737 8.8 ZN
16	F03150993	PIATTO X COLLARE SUPERIORE ZN	PLATE	PLAT	PLATTE	PLATO
17	F03150992	COPPIA COLLARI X TUBO D.16	DOUBLE SUPPORT	SUPPORT DOUBLE	DOPPELHALTER	SOPORTE DOBLE
18	M06716518	TELAIO GF.160 SX	FRAME GF.160	RAHMEN GF.160	CHASSIS GF.160	BASTIDOR GF.160
19	M06719518	TELAIO GF.185 SX	FRAME GF.185	RAHMEN GF.185	CHASSIS GF.185	BASTIDOR GF.185
20	M06721518	TELAIO GF.210 SX	FRAME GF.210	RAHMEN GF.210	CHASSIS GF.210	BASTIDOR GF.210
21	F01010318	VITE M14X 1,5X40 U5740 8.8 ZN	BOLT M 14X1,5X40	VIS M 14X1,5X40	SCHRAUBE M 14X1,5X40	TORNILLO M 14X1,5X40
22	F01220059	DADO M14X 1,5 D980 8 ZN	NUT M14X 1,5 D980 8 ZB	ECROU M14X 1,5 D980 8 ZB	MUTTER M14X 1,5 D980 8 ZB	TUERCA M14X 1,5 D980 8 ZB
23	F01410088	ROS.M14 15X 28X2,5 U6592 ZN	WAS.M14 15X 28X2,5 U6592 ZB	RON.M14 15X 28X2,5 U6592 ZB	SCH.M14 15X 28X2,5 U6592 ZB	ARA.M14 15X 28X2,5 U6592 ZB
24	F01010288	VITE M12X1,25X35 U5740 8.8 ZN	BOLT M12X1,25X35 U5740 8.8 ZN	VIS M12X1,25X35 U5740 8.8 ZN	SCHR.M12X1,25X35 U5740 8.8 ZN	TORN.M12X1,25X35 U5740 8.8 ZN
25	M30400528	COMP. ATTACCO SCATOLA GF	BRACKET	PLATTE	PLAQUETTE	PLAQUITA
26	M07400203	MOLTIPLIC. GIRAFFA S.I. BO*540	GEARBOX	WECHSELGETRIEBEGEHAUSE	BOITE DE VITESSE	CAJA CAMBIO
28	M37100106	ATTACCO PROTEZIONE	PROTECTION SUPPORT	SUPPORT PROTECTION CARDAN	GELENKWELLENSCHUTZ HALTER	SOPORTE PROTECCION CARDANICO
29	F01410051	ROS.M8 8,4X 17X1,6 U6592 ZN	WASHER M8 8,4X17X1,6 U6592 ZN	RONDEL. M8 8,4X17X1,6 U6592 ZN	SCHIEBE M8 8,4X17X1,6 U6592 ZN	ARANDELA M8 8,4X17X1,6 U6592 ZN
30	F01020432	VITE M 8X1,25X16 U5739 8.8 ZN	BOLT M8X 1.25X16 U5739 8.8 ZN	VIS M 8X16	SCHRAUBE M 8X16	TORNILLO M 8X16
31	M68100106	PROTEZIONE CARDANO	CARDAN PROTECTION	PROTECTION CARDAN	GELENKWELLENSCHUTZ	PROTECCION CARDANICO
32	F01410037	ROS.M6 6,4X12,5X1,6 U6592 ZN	PLANE WASHER D.6	RONDELLE D.6	SCHIEBE D.6	ARANDELA D.6
33	F01020403	VITE M6X1X16 U5739 8.8 ZN	BOLT M6X1X16 U5739 8.8 ZN	VIS M6X1X16 U5739 8.8 ZN	SCHRAUBE M6X1X16 U5739 8.8 ZN	TORNILLO M6X1X16 U5739 8.8 ZN
34	F01010323	VITE M14X1,5 X70 U5740 8.8 ZN	BOLT M14X1,5X70 U5740 8.8 ZN	VIS M 14X1,5X70	SCHRAUBE M 14X1,5X70	TORNILLO M 14X1,5X70
35	F01200089	DADO M14X 1,5 U5587 6S ZN	NUT M14X 1,5 U5581 6S ZB	ECROU M14X 1,5 U5587 6S ZB	MUTTER M14X 1,5 U5587 6S ZB	TUERCA M14X 1,5 U5587 6S ZB
36	F01230179	DADO M42X 3 D982 8 ZN	SELF LOCKING NUT M42X3	ECROU AUTOBL. M42X3	SELBSTSPERR.MUTTER M42X3	DADO AUTOBL. M42X3
37	M07400525	ROSETTA DI BLOCCAGGIO	PLANE WASHER	RONDELLE	SCHIEBE	ARANDELA
38	F04100105	BOCCOLA D=85 D=80 L=60 AUTOLUB	BUSHING D=85 D=80 L=60	BOUCLE D=85 D=80 L=60	BUECHSE D=85 D=80 L=60	ARANDELA D=85 D=80 L=60
39	M06792505	GIUNTO MOVIMENTAZIONE SX	JOINT	VERBINDUNG	JOINT	JUNTA
40	M07400592	COMP.PERNO D=30 L=119	PIN	GOUJON	STIFT	PERNO

----- CONTINUA A PAGINA SEGUENTE -----

----- CONTINUED ON NEXT PAGE -----

**TELAIO SINISTRO
LEFT HAND FRAME**

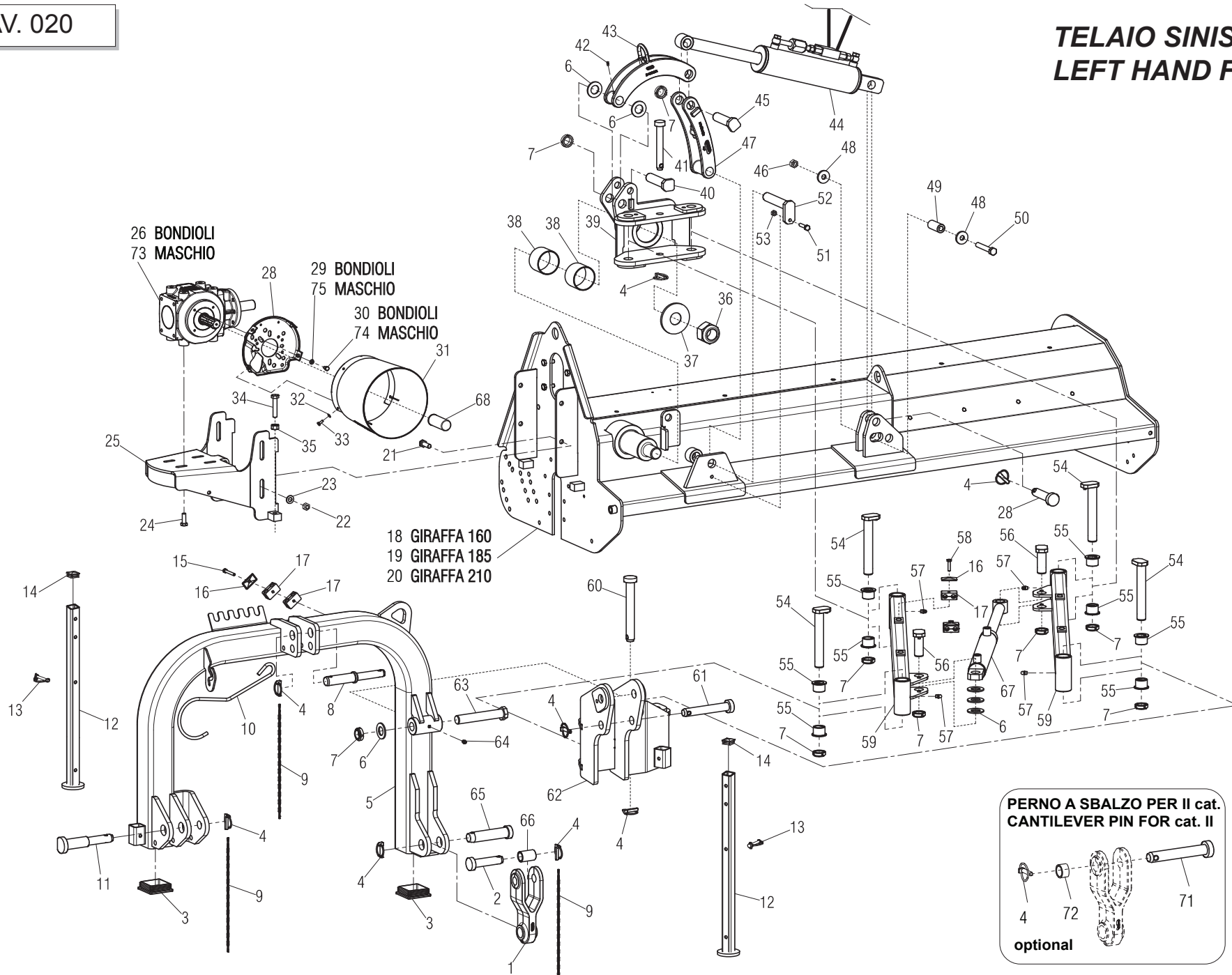

TELAIO SINISTRO E TERZO PUNTO / LEFT FRAME AND 3rd POINT HITCH

TAV. 020

Pos.	Cod.	Descrizione	Description	Benennung	Description	Description
----- CONTINUA DA PAGINA PRECEDENTE ----- ----- CONTINUED FROM PRECEDING PAGE -----						
41	F20100115	PERNO D22 L144 ZN	GASPARDO PIN 22X144 ZN	GOUPILLE GASPARDO 22X144 ZN	GASPARDO-STIFT 22X144 ZN	PASADOR GASPARDO 22X144 ZN
42	F01100011	ING.M 6X1 7663-A 9SMNPB28 ZN	GREASE NIPPLE M6X1 7663-A ZN	GRAISS. A BILLE M6X1 7663A ZN	SCHMIERBUECHE M6X1 7663-A ZN	ENGRAS. DE ESFERAS M6X1 7663-A
43	M30400546	BIELLA SUPERIORE IN CERA PERSA	UPPER CONNECTION ROD	BIELLE ATTELAGE	PLEUELSTANGE	BIELA ATAQUE
44	M30400530	MARTINETTO ID.A=80 C=273 L=566	CYLINDER A=80 C=273 L=566	MANIVELLE HYDRAULIQUE	HYDRAUL.SPINDELVERSTELLUNG	GATO HIDRAULICO
45	M07400598	COMP.PERNO D=30 L=109	PIN D=30 L=109	GOUJON D=30 L=109	STIFT D=30 L=109	PERNO D=30 L=109
46	F01220070	DADO M16X 1,5 D980 8 ZN	NUT M16X 1,5 D980 8 ZB	ECRO.M16X 1,5 D980 8 ZB	MUTT.M16X 1,5 D980 8 ZB	TUER.M16X 1,5 D980 8 ZB
47	M06700515	BIELLA INFERIORE SENZA FERMO	CONNECTION ROD	PLEUEL	BIELLE	VARILLA
48	F01500023	ROS. 17 X45X6 D6340 C50 ZD	ELASTIC DISK	DISQUE ELASTIQUE	ELASTISCHE SCHEIBE	DISCO ELASTICO
49	M50400556	DISTANZIALE D=30 D=20 L=65	SPACER D=30 D=20 L=65	ENTRETOISE D=30 D=30 L=65	DISTANZST.D=30 D=20 L=65	DISTANCIAD.D=30 D=20 L=65
50	F01010124	VIT.M16X 1,5X100 U5738 8.8 ZN	BOLT M16X1,5X100	VIS M16X1,5X100	SCHRAUBE M16X1,5X100	TORNILLO M16X1,5X100
51	F01010026	VITE M10X1,25X40 U5738 8.8 ZN	BOLT M 10X1,25X40	VIS M 10X1,25X40	SCHRAUBE M 10X1,25X40	TORNILLO M 10X1,25X40
52	M07400596	COMP.PERNO D=30 L=150	PIN	GOUJON	STIFT	PERNO
53	F01220034	DADO M10X1,25 D980 8 ZN	NUT M10X1,25 D980 8 ZB	ECRO.M10X1,25 D980 8 ZB	MUTT.M10X1,25 D980 8 ZB	TUER.M10X1,25 D980 8 ZB
54	M07400726	PERNO D=30 L= 199	PIN D=30 L= 199	GOUJON D=30 L= 199	BOLZEN D=30 L= 199	PERNO D=30 L= 199
55	M07400929	BOCCOLA D=30 D=40 L=30	BUSHING D=30 D=40 L=30	BOUCLE D=30 D=40 L=30	BUECHSE D=30 D=40 L=30	ARANDELA D=30 D=40 L=30
56	M06700512	PERNO D=30 L= 78	PIN D=30 L= 78	GOUJON D=30 L= 78	BOLZEN D=30 L= 78	PERNO D=30 L= 78
57	F01100063	ING.M10X1 7663-C 9SMNPB28 ZN	GREASE NIPPLE	SCHMIERBUECHSE	GRAISSEUR	ENGRASADOR
58	F01020449	VITE M 8X1,25X35 U5739 8.8 ZN	BOLT M8X 1.25X35 U5739 8.8 ZN	VIS M 8X35	SCHRAUBE M 8X35	TORNILLO M 8X35
59	M30400555	COMP. PARALLELOGRAMMA UNIFICAT	ARM	ARM	BRAS	BRAZO
60	F20100077	PERNO D=28 L=194 ZN	PIN D=28 L=200	GOUJON D=28 L=200	STIFT D=28 L=200	PERNO D=28 L=200
61	F20100076	PERNO D28 L154 C40 ZN	BOLT D28 L154 C40 ZN	BOULON D28 L154 C40 ZN	BOLZEN D28 L154 C40 ZN	PERNO D28 L154 C40 ZN
62	M06700510	COMPOSTO ATTACCO 3° PUNTO SX	COUPLING	KUPPLUNG	FIXATION	CONEXIN
63	M07400589	COMP.PERNO D=30 L=179	PIN	GOUJON	STIFT	PERNO
64	F01100061	ING.M10X1 7663-A 9SMNPB28 ZN	GREASE NIPPLE M10X1 7663-A ZN	GRAISSEUR M10X1 7663-A ZN	SCHMIERBUECHSE M10X1 7663-A ZN	ENGRASADOR M10X1 7663-A ZN
65	F20100141	PERNO D36 L128 C43 ZN	PIN D36 L128 C43 ZN	BOULON D36 L128 C43 ZN	BOLTZEN D36 L128 C43 ZN	PERNO D36 L128 C43 ZN
66	M68100932	BUSSOLA	BUSHING	BOUSSOLE	BUECHSE	BRUJULA
67	M07400588	COMP. MART.IDR.A=50 C=314 L616	CYLINDER A=50 C=314 L=616	VERIN	SPINDELVERSTELLUNGSTEIL	MARTINETE
68	M38100146	MANICOTTO PROTEZIONE PDF 1"3/8	P.T.O. PROTECTION	MANCHON DE PROTECTION P.T.O.	ZAPFWELLENSCHUTZ P.T.O.	MANGUITO PROTECCION P.T.O.
69	F20100138	PERNO D28 L154 C43 ZN	PIN D28 L154 C43 ZN	BOLTZEN D25 L154 C43 ZN	BOULON D28 L154 C43 ZN	PERNO D28 L154 C43 ZN
70	M36200944	DISTANZIALE MARTINETTO	SPACER	DISTANZSTUECK	ENTRETOISE	DISTANCIADOR
71	F20100138	PERNO D28 L154 C43 ZN	PIN D28 L154 C43 ZN	BOLTZEN D25 L154 C43 ZN	BOULON D28 L154 C43 ZN	PERNO D28 L154 C43 ZN
72	M36200944	DISTANZIALE MARTINETTO	SPACER	DISTANZSTUECK	ENTRETOISE	DISTANCIADOR
73	M07400201	MOLTIPLIC. GF.SI.DX-SE.SX MASCHIO	GEARBOX	WECHSELGETRIEBEGEHAUESE	BOITE DE VITESSE	CAJA CAMBIO
74	F01020468	VITE M10X1,5 X16 U5739 8.8 ZN	BOLT M10X1,5 X 16	DUEBEL M10X1,5 X 16	RONDELLE M10X1,5 X 16	TORNILLO M10X1,5 X 16
75	F01410064	ROS.M10 10,5X 20X 2 U6592 ZN	WASHER M10 10,5X20X2 U6592 ZN	SCHEIBE M10 10,5X20X2 U6592 ZN	RONDELL.M10 10,5X20X2 U6592 ZN	ARAND. M10 10,5X20X2 U6592 ZN

**PATTINI ANTIUSURA
WEAR-RESISTANT SKIDS**

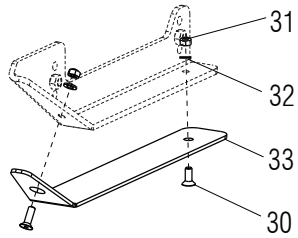

optional

- 20 GIRAFFA 160
- 21 GIRAFFA 185
- 22 GIRAFFA 210

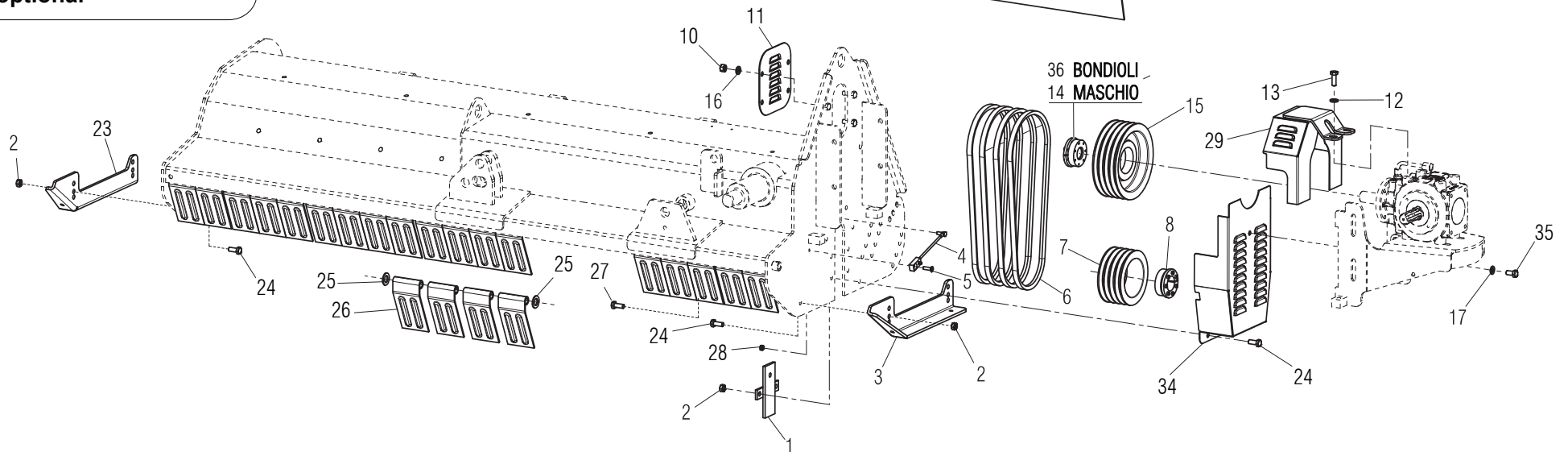
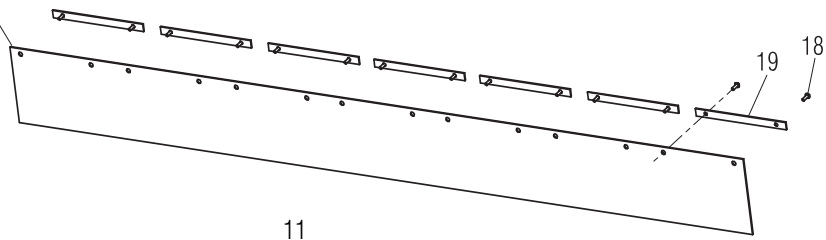

TRASMISSIONE / TRANSMISSION

TAV. 030

Pos.	Cod.	Descrizione	Description	Benennung	Description	Description
1	M07400531	COPRI ASOLA	REAR LATERAL PANEL	HINTERE BLECH	CAPOT ARRIERE LATERAL	PLANCHA LATERALE
2	F01220047	DADO M12X1,25 D980 8 ZN	NUT M12X1,25 D980 8 ZN	MUTTER M12X1,25 D980 8 ZN	ECROU M12X1,25 D980 8 ZN	TUERCA M12X1,25 D980 8 ZN
3	M30400535	SLITTA LATO TRASMISSIONE	TRANSMISSION SIDE SKID	0	0	0
4	T24004000	ASSIEME INGRASSATORE	GREASE NIPPLE	SCHMIERNIPPEL	GRAISSEUR	ENGRASADOR
5	F01030058	VITE M 8X1,25X 30 U5933 10.9ZD	BOLT M8X1,25X30 U5933 10,9 ZD	SCHRAUBE M8X1,25X30 U5933 10,9	VIS M8 X1,25 X30 U5933 10,9 ZD	TORNILLO M8X1,25X30 U5933 10,9
6	F06010039	CINGHIA SPBX L=1320	BELT SPBX L=1320	SCHAUBE SPBX L=1320	COURROIE SPBX L=1320	CORREA SPBX L=1320
7	T16003005	PULEGGIA DP=160 A 4 GOLE	PULLEY	SCHEIBE	POULIE	ROLDANA
8	F06060039	CALETTATORE AUTOCENTR.45X80	SELF LOCKING KEYNG 45X80	0	0	0
9	T16003150	COMP.CARTER	COMPLETE CARTER	0	0	0
10	F01200073	DADO M12X1,25 U5587 6S ZN	NUT M12X1,25 U5587 6S ZN	MUTTER M12X1,25 U5587 6S ZN	ECROU M12X1,25 U5587 6S ZN	TUERCA M12X1,25 U5587 6S ZN
11	M07400939	CARTER FIANCATA	CARTER	GEHAEUSE	CARTER	CARTER
12	F01480123	ROS.G 12,5X22,9X 4 FLZNNC-240H	WASHER M12 ZGP EXTRA P.	UNTERLEGSCHEIBE M12 ZGP EXTRA	RONDELLE M12 ZGP EXTRA P.	ARANDELA M12 ZGP EXTRA P.
13	F01020512	VITE M12X1,75X 35 U5739 8.8ZN	BOLT M12X1,75X35 5739 8.8 ZN	SCHR. M12X1,75X35 5739 8.8 ZN	VIS M12X1,75X35 5739 8.8 ZN	TORN. M12X1,75X35 5739 8.8 ZN
14	F06060036	CALETTATORE AUTOC. 33X80	SELF LOCKING KEYNG 33X80	SELBSTPERR.VERKEILEN 33X80	EMBOITAGE AUOBL. 33X80	ENSAMBLADURA AUTOBL. 33X80
15	T30003002	PULEGGIA ROTORE D=224 4V	DRIVING PULLEY	ZIEHEN RIEMEN	POULIE TIRANTE	ROLDANA DE TIRAR
18	F02250160	RIVETTO STR. 6,4X22 ACCIAIO	RIVET	KUPFERNIET	RIVET	REMACHE
19	M07400953	PIATTO PER ATTACCO GOMMA	PLATE	PLATTE	PLAT	PLATO
20	T24155681	PROTEZ. POSTERIORE PVC L=1530	REAR GUARD PVC L=1530	0	0	0
21	T24195681	PROTEZ. POSTERIORE PVC L=1880	REAR GUARD PVC L=1880	0	0	0
22	T24215681	PROTEZ. POSTERIORE PVC L=2080	REAR GUARD PVC L=2080	0	0	0
23	M30400536	SLITTA LATO ESTERNO GF	SIDE PANEL SKID	0	0	0
24	F01010283	VITE M12X1,25X 30 U5740 8.8ZN	BOLT M 12X1,25X30	SCHRAUBE M 12X1,25X30	VIS M 12X1,25X30	TORNILLO M 12X1,25X30
25	F01410124	ROS.M20 21X 37X 3 U6592 ZN	WASHER M20 21X 37X 3 U6592 ZN	0	0	0
26	M24400518	BANDELLA PROTEZ. 93X170 ZN	PROTECTION BAR	SCHUTZWORNE	BANDE PROTECTION	ALETA PROTECCION
27	F01010317	VITE M14X1,5 X 35 U5740 8.8ZN	BOLT M14X1,5X35 U5740 8.8 ZN	SCHRAUBE M 14X1,5X35	VIS M 14X1,5X35	TORNILLO M 14X1,5X35
28	F01220022	DADO M 8X1,25 D980 8 ZN	NUT M8X 1,25 D980 8 ZN	MUTTER M8X 1,25 D980 8 ZN	ECROU M8X 1,25 D980 8 ZN	TUERCA M8X 1,25 D980 8 ZN
29	M07400932	CARTER ALTO	CARTER	GEHAEUSE	CARTER	CARTER
30	F01030058	VITE M 8X1,25X 30 U5933 10.9ZD	BOLT M8X1,25X30 U5933 10,9 ZD	SCHRAUBE M8X1,25X30 U5933 10,9	VIS M8 X1,25 X30 U5933 10,9 ZD	TORNILLO M8X1,25X30 U5933 10,9
31	F01220022	DADO M 8X1,25 D980 8 ZN	NUT M8X 1,25 D980 8 ZN	MUTTER M8X 1,25 D980 8 ZN	ECROU M8X 1,25 D980 8 ZN	TUERCA M8X 1,25 D980 8 ZN
32	F01410051	ROS.M8 8,4X 17X1,6 U6592 ZN	WASHER M8 8,4X17X1,6 U6592 ZN	SCHEIBE M8 8,4X17X1,6 U6592 ZN	RONDELLE M8 8,4X17X1,6 U6592ZN	ARANDELA M8 8,4X17X1,6 U6592ZN
33	M30400537	SLITTA ANTIUSURA GF OPTIONAL	ANTIWEAR SKID GF OPTIONAL	0	0	0
34	M07400934	CARTER BASSO	CARTER	GEHAEUSE	CARTER	CARTER
35	F01010281	VITE M12X1,25X 25 U5740 8.8ZN	BOLT M 12X1,25X25	SCHRAUBE M 12X1,25X25	VIS M 12X1,25X25	TORNILLO M 12X1,25X25
36	F06060037	CALETTATORE AUTOCENTR.35X80	SELF LOCKING KEYNG 35X80	SELBSTPERR.VERKEILEN 35X80	EMBOITAGE AUOBL. 35X80	ENSAMBLADURA AUTOBL. 35X80

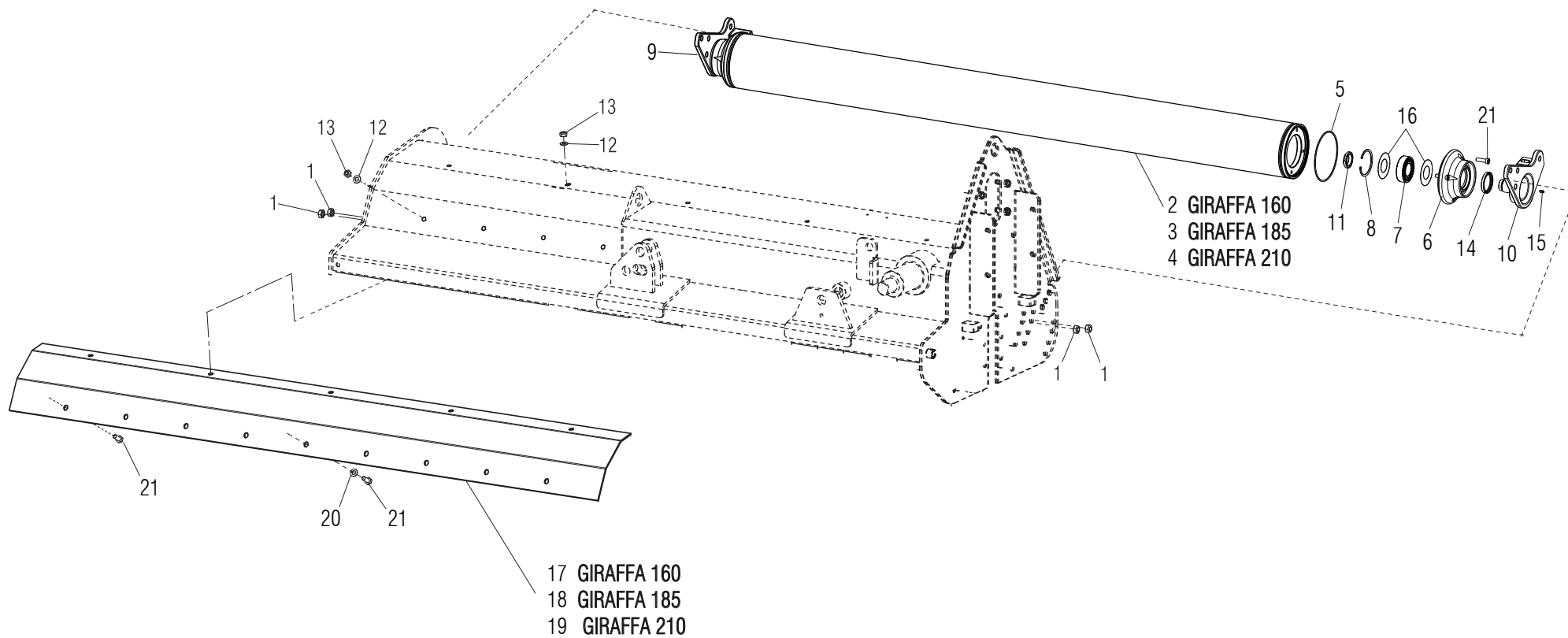

RULLO ED OPTIONALS / ROLLER AND OPTIONALS

TAV. 040

Pos.	Cod.	Descrizione	Description	Benennung	Description	Description
1	F01220059	DADO M14X 1,5 D980 8 ZN	NUT M14X 1,5 D980 8 ZB	MUTTER M14X 1,5 D980 8 ZB	ECROU M14X 1,5 D980 8 ZB	TUERCA M14X 1,5 D980 8 ZB
2	M30415602	ASSIEME RULLO MOD.150	ROLLER ASSEMBLY MOD.150	LAEUFER KOMPL. MOD.150	ROTOR COMPL. MOD.150	ROTOR COMPL. MOD.150
3	M30419602	ASSIEME RULLO MOD.190	ROLLER ASSEMBLY MOD.190	LAEUFER KOMPL. MOD.190	ROTOR COMPL. MOD.190	ROTOR COMPL. MOD.190
4	M30421602	ASSIEME RULLO MOD.210	ROLLER ASSEMBLY MOD.210	LAEUFER KOMPL. MOD.210	ROTOR COMPL. MOD.210	ROTOR COMPL. MOD.210
5	F03010758	ANEL. OR 148,82X3,53 NBR 70	GASKET OR 148,82X3,53 NBR 70	RING OR 148,82X3,53 NBR 70	BAGUE OR 148,82X3,53 NBR 70	ANILLO OR 148,82X3,53 NBR 70
6	M30400607	SUPPORTO CUSCINETTO RULLO	ROLLER SUPPORT	WALZEHALTER	SUPPORT ROULEAU	SOPORTE RODILLO
7	F04010327	CUSC.D40 D80 B23 62208 2RS1	BEARING D40 D80 B23 62208 2RS1	LAGER D40 D80 B23 62208 2RS1	ROULEMENT D40 D80 B23 62208 2RS1	COJINETTE D40 D80 B23 62208 2RS1
8	F02050425	ANELLO E. DI 80X 2,5 U7437 C70	SEEGER RING D.80	SEEGERRING D.80	BAGUE SEEGER D.80	ANILLO SEEGER D.80
9	M30400608	STAFFA RULLO DX	ROLLER SUPPORT	WALZEHALTER	SUPPORT ROULEAU	SOPORTE RODILLO
10	M30400609	STAFFA RULLO SX	ROLLER SUPPORT	WALZEHALTER	SUPPORT ROULEAU	SOPORTE RODILLO
11	F02010022	GHIERA AU.GUK M35X1,5 T.4H ZN	SELF LOCKING NUT M35X1,5	SELBSTSP. NUTMUTTER M35X1,5	COLLIER AUTOBL. M35X1,5	VIROLA AUTOBL. M35X1,5
12	F01410076	ROS.M12 13X 24X2,5 U6592 ZN	WASHER D12 U6592 ZN	SCHEIBE D12 U6592 ZN	RONDELLE D12 U6592 ZN	ARANDELA D12 U6592 ZN
13	F01220047	DADO M12X1,25 D980 8 ZN	NUT M12X1,25 D980 8 ZN	MUTTER M12X1,25 D980 8 ZN	ECROU M12X1,25 D980 8 ZN	TUERCA M12X1,25 D980 8 ZN
14	F03010160	ANELLO T.A. 50X 65X 8 D3760NBR	OIL SEAL 50X65X8	OELABDICHTUNG 50X65X8	PARE-HUILE 50X65X8	PARA-ACEITE 50X65X8
15	F01100011	ING.M 6X1 7663-A 9SMNPB28 ZN	GREASE NIPPLE M6X1 7663-A ZN	SCHMIERBUECHE M6X1 7663-A ZN	GRAISS. A BILLE M6X1 7663A ZN	ENGRAS. DE ESFERAS M6X1 7663-A
16	M30400617	ROSETTA SPESS. D=80 D=42 0,5	WASHER M10 10,5X20X2 U6592 ZN	SCHEIBE M10 10,5X20X2 U6592 ZN	RONDELL.M10 10,5X20X2 U6592 ZN	ARAND. M10 10,5X20X2 U6592 ZN
17	M07416738	LAMIERA ANTIUSURA GF 160	DOUBLE SKIN FRAME GF160	SCHLEISSBLECH GF160	TOLE DE BLINDAGE GF160	CHAPA ANTIDESGASTE GF160
18	M07419738	LAMIERA ANTIUSURA GF 190	DOUBLE SKIN FRAME GF190	SCHLEISSBLECH GF190	TOLE DE BLINDAGE GF190	CHAPA ANTIDESGASTE GF190
19	M07421738	LAMIERA ANTIUSURA GF 210	DOUBLE SKIN FRAME GF210	SCHLEISSBLECH GF210	TOLE DE BLINDAGE GF210	CHAPA ANTIDESGASTE GF210
20	F01480123	ROS.G 12,5X22,9X 4 FLZNNC-240H	WASHER M12 ZGP EXTRA P.	UNTERLEGSCHLEIBE M12 ZGP EXTRA	RONDELLE M12 ZGP EXTRA P.	ARANDELA M12 ZGP EXTRA P.
21	F01040110	VIT.M10X1,25X 35 U5931 8.8 ZN	BOLT M10X1,25X35 U5931 8.8 ZN	SCHRAUBE M10X1,25X35 U5931 8.8	VIS M10X1,25X35 U5931 8.8 ZN	TORNILLO M10X1,25X35 U5931 8.8

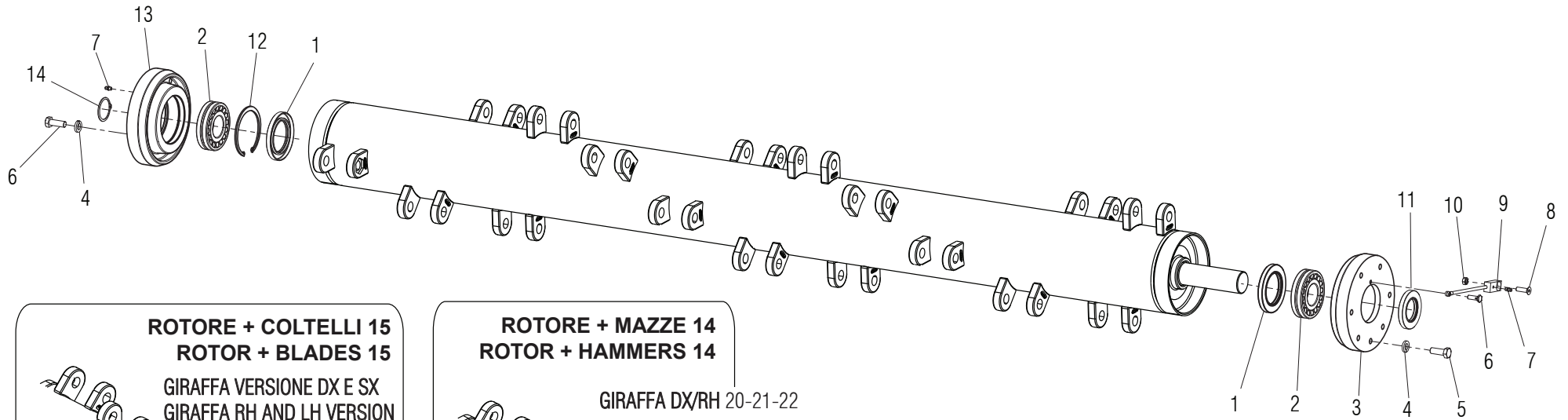

ROTORE + COLTELLI 15
ROTOR + BLADES 15

GIRAFFA VERSIONE DX E SX
GIRAFFA RH AND LH VERSION

23-24-25

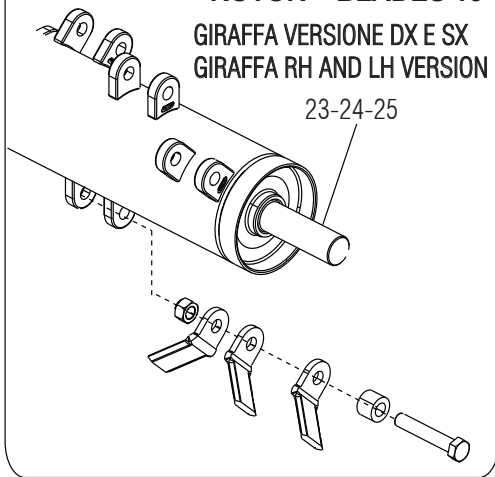

ROTORE + MAZZE 14
ROTOR + HAMMERS 14

GIRAFFA DX/RH 20-21-22
GIRAFFA SX/LH 26-27-28

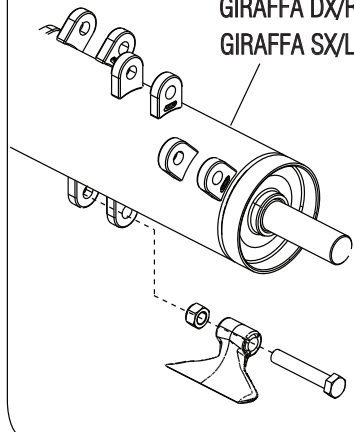

COLTELLO 15
BLADE 15

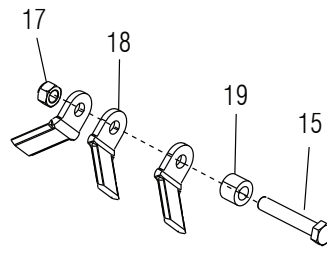

MAZZA 14
HAMMER 14

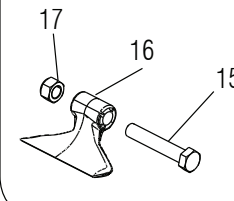

ROTORE / ROTOR

TAV. 050

Pos.	Cod.	Descrizione	Description	Benennung	Description	Description
1	F03010218	ANELLO T.A. 65X100X10 D3760NBR	OIL SEAL 65X100X10	OELABDICHTUNG 65X100X10 D3760	PARE-HUILE 65X100X10 D3760NBR	ANILLO 65X100X10
2	F04010031	CUSC.D45 D100 B25 21309	BEARING D45 D100 B25 6309	LAGER D45 D100 B25	ROULEMENT D45 D100 B25	COJINETE D45 D100 B25
3	T30004008	SUPPORTO ROTORE SX	LEFT ROTOR SUPPORT	ROTORHALTER	SUPPORT ROTOR	SOPORTE ROTOR
4	F01480123	ROS.G 12,5X22,9X 4 FLZNNC-240H	WASHER M12 ZGP EXTRA P.	UNTERLEGSCHLEIBE M12 ZGP EXTRA	RONDELLE M12 ZGP EXTRA P.	ARANDELA M12 ZGP EXTRA P.
5	F01010288	VITE M12X1,25X35 U5740 8.8 ZN	BOLT M12X1,25X35 U5740 8.8 ZN	SCHR.M12X1,25X35 U5740 8.8 ZN	VIS M12X1,25X35 U5740 8.8 ZN	TORN.M12X1,25X35 U5740 8.8 ZN
6	T24004003	VITE FORATA PER INGRASSAGGIO	BOLT	SCHRAUBE	VIS	TORNILLO
7	F01100011	ING.M 6X1 7663-A 9SMNPB28 ZN	GREASE NIPPLE M6X1 7663-A ZN	SCHMIERBUECHE M6X1 7663-A ZN	GRAISS. A BILLE M6X1 7663A ZN	ENGRAS. DE ESFERAS M6X1 7663-A
8	F01030058	VITE M 8X1,25X30 U5933 10,9 ZD	BOLT M8X1,25X30 U5933 10,9 ZD	SCHRAUBE M8X1,25X30 U5933 10,9	VIS M8 X1,25 X30 U5933 10,9 ZD	TORNILLO M8X1,25X30 U5933 10,9
9	T24004000	ASSIEME INGRASSATORE	GREASE NIPPLE	SCHMIERNIPPEL	GRAISSEUR	ENGRASADOR
10	F01220022	DADO M 8X1,25 D980 8 ZN	NUT M8X 1,25 D980 8 ZN	MUTTER M8X 1,25 D980 8 ZN	ECROU M8X 1,25 D980 8 ZN	TUERCA M8X 1,25 D980 8 ZN
11	F03010139	ANELLO T.A. 45X 80X10 D3760NBR	OIL SEAL 45X 80X10 D3760NBR	OELABDICHTUNG 45X 80X10 D3760	BOURRAGE 45X 80X10 D3760NBR	JUNTA DE ACEITE 45X 80X10
12	F02050471	ANELLO E. DI100X 3 U7437 C70	SEEGER RING D.100	SEEGERRING D.100	BAGUE SEEGER D.100	ANILLO SEEGER D.100
13	T30004007	SUPPORTO ROTORE DX	RIGHT ROTOR SUPPORT	HALTERUNG	SUPPORT	SOPORTE
14	F02050191	ANELLO E. DE 45X1,75 U7435 C70	RING 45X1,75 U7435 C70	EXT.RING DE 45X1,75 U7435 C70	BAGUE ELASTIQUE UNI 7435	ANILLO DE 45X1,75 U7435 C70
15	F20110092	VIT. M20X1.5X116 SPEC. BR.8.8	BOLT M20X1.5X116 SPEC. BR.8.8	BOZEN M20X1.5X116 SPEC. BR.8.8	VIS M20X1.5X116 SPEC. BR.8.8	TORNILLO AUTOBL. M20X1
16	M03400410	MAZZA 14	HAMMER 14	SCHLEDEL	MARTEAUX	CUCHILLAS 14
17	F01230258	DADO M20X 1,5 U7474 8S ZN	SELF LOCKING NUT M20X1,5	SELBSTSPERR.MUTTER M20X1,5	ECROU AUTOBL. M20X1,5	DADO AUTOBL. M20X1,5
18	M03400406	COLTELLO 15 A Y	BLADE "Y" 15	MESSER "Y" 15	COUTEAU "Y" 15	CUCHILLO "Y" 15
19	M03400407	DISTANZIALE D=38 D=20 L=29 ZN	BUSHING	BUECHSE	BOUCLE	ARANDELA
20	M097154011	COM.ROT.CR155-GF160 M14 NO SUP	ROTOR + HAMMER 160	MESSERHAL ROTOR+SCHLEDEL 160	ROTOR PORTE COUTEAUX+MART. 160	ROTOR PORTA AZADA+MARTILLO 160
21	M097194011	COM.ROT.CORAZZA190 M14 NO SUP	ROTOR + HAMMER 185	MESSERHAL ROTOR+SCHLEDEL 185	ROTOR PORTE COUTEAUX+MART. 185	ROTOR PORTA AZADA+MARTILLO 185
22	M097214011	COM.ROT.CR210-GF210 M14 NO SUP	ROTOR + HAMMER 210	MESSERHAL ROTOR+SCHLEDEL 210	ROTOR PORTE COUTEAUX+MART. 210	ROTOR PORTA AZADA+MARTILLO 210
23	M097154021	COM.ROT.CR155-GF160 C15 NO SUP	ROTOR + KNIFE 160	MESSERHAL ROTOR+MESSER 160	ROTOR PORTE COUTEAUX+COUT. 160	ROTOR PORTA AZADA+CUCHILLAS 160
24	M097194021	COM.ROT.CORAZZA190 C15 NO SUP	ROTOR + KNIFE 185	MESSERHAL ROTOR+MESSER 185	ROTOR PORTE COUTEAUX+COUT. 185	ROTOR PORTA AZADA+CUCHILLAS 185
25	M097214021	COM.ROT.CR210-GF210 C15 NO SUP	ROTOR + KNIFE 210	MESSERHAL ROTOR+MESSER 210	ROTOR PORTE COUTEAUX+COUT. 210	ROTOR PORTA AZADA+CUCHILLAS 210
26	M067154101	COM.ROT. GF 160 M14 NO SUP SX	ROTOR + HAMMER 160 LH	MESSERHAL ROTOR+SCHLEDEL 160	ROTOR PORTE COUTEAUX+MART. 160	ROTOR PORTA AZADA+MARTILLO 160
27	M067194101	COM.ROT. GF 190 M14 NO SUP SX	ROTOR + HAMMER 185 LH	MESSERHAL ROTOR+SCHLEDEL 185	ROTOR PORTE COUTEAUX+MART. 185	ROTOR PORTA AZADA+MARTILLO 185
28	M067214101	COM.ROT. GF 210 M14 NO SUP SX	ROTOR + HAMMER 210 LH	MESSERHAL ROTOR+SCHLEDEL 210	ROTOR PORTE COUTEAUX+MART. 210	ROTOR PORTA AZADA+MARTILLO 210

ROTORE MULTIAGGRESSIVO
MULTIAGGRESSIV ROTOR

ROTORE + MAZZE 20
ROTOR + HAMMERS 20

GIRAFFA DX/RH 13-14-15
GIRAFFA SX/LH 19-20-21

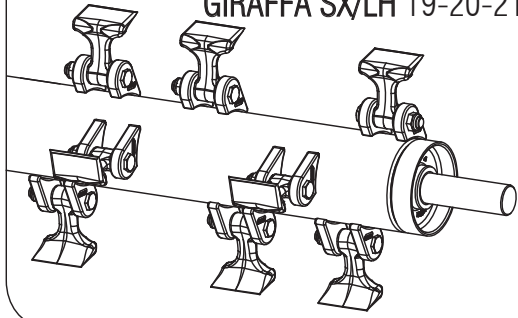

ROTORE + COLTELLI 18
ROTOR + BLADES 18

GIRAFFA DX/RH 16-17-18
GIRAFFA SX/LH 22-23-24

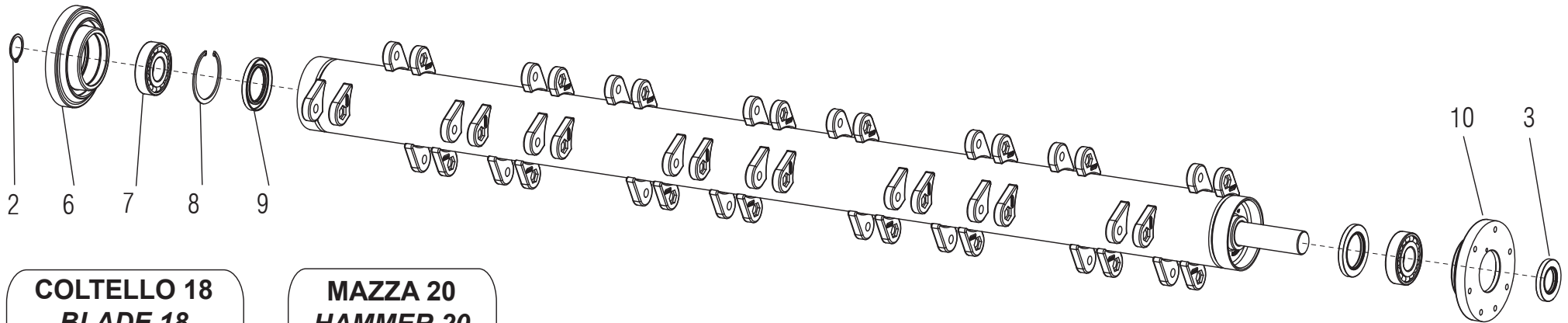
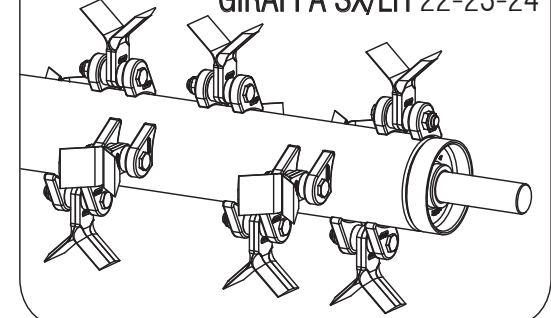

COLTELLO 18
BLADE 18

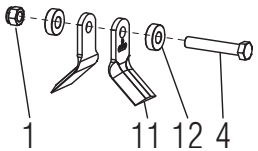

MAZZA 20
HAMMER 20

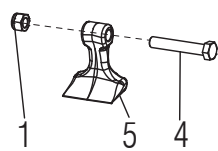

ROTORE MULTIAGGRESSIVO / MULTIAGGRESSIV ROTOR

TAV. 060

Pos.	Cod.	Descrizione	Description	Benennung	Description	Description
1	F01230084	DADO M16X1,5 D982 6 ZN	SELF LOCKING NUT M16X1,5	SELBSTSPERR.MUTTER M16X1,5	ECROU AUTOBL. M16X1,5	DADO AUTOBL. M16X1,5
2	F02050191	ANELLO E. DE 45X1,75 U7435 C70	RING 45X1,75 U7435 C70	EXT.RING DE 45X1,75 U7435 C70	BAGUE ELASTIQUE UNI 7435	ANILLO DE 45X1,75 U7435 C70
3	F03010139	ANELLO T.A. 45X 80X10 D3760NBR	OIL SEAL 45X 80X10 D3760NBR	OELABDICHTUNG 45X 80X10 D3760	BOURRAGE 45X 80X10 D3760NBR	JUNTA DE ACEITE 45X 80X10
4	F20110093	VIT. M16X1.5X95 SPEC. BR.10.9	BOLT M16X1.5X95 SPEC. BR.10.9	SCHRAUBE M16X1.5X95 SPEC.	VIS M16X1.5X95 SPEC. BR.10.9	TORNILLO M16X1.5X95 SPEC.
5	M30400415	MAZZA*20 STAMPATA MAG	HAMMER 20 MAG			
6	M25400409	SUPPORTO ROTORE LATO ESTERNO	ROTOR SUPPORT SIDE PANEL	ROTORHALTER SEITENWAND	SUPPORT ROTOR PARTIE LATERALE	SOPORTE ROTOR FLANCO
7	F04010031	CUSC.D45 D100 B25 21309	BEARING D45 D100 B25 6309	LAGER D45 D100 B25	ROULEMENT D45 D100 B25	COJINETE D45 D100 B25
8	F02050471	ANELLO E. DI100X 3 U7437 C70	SEEGER RING D.100	SEEGERRING D.100	BAGUE SEEGER D.100	ANILLO SEEGER D.100
9	F03010218	ANELLO T.A. 65X100X10 D3760NBR	OIL SEAL 65X100X10	OELABDICHTUNG 65X100X10 D3760	PARE-HUILE 65X100X10 D3760NBR	ANILLO 65X100X10
10	M25400410	SUPPORTO ROTORE LATO TRASMISS.	ROTOR SUPPORT TRANSM. SIDE	ROTORHALTER TRANSMISSIONSEITE	SUPPORT ROTOR COTE TRANSM.	SOPORTE ROTOR LADO TRASMISSION
11	M07400954	COLTELLO*18	KNIFE*18			
12	T21004046	DISTANZIALE COLTELLO ZN	SPACER KNIFE	BUECHSE	BOUCLE	ARANDELA
13	M304154011	ROTORE DX + MAZZA*20 GF160	ROTOR + HAMMER 160	MESSERHAL ROTOR+SCHLEGEL 160	ROTOR PORTE COUTEAUX+MART. 160	ROTOR PORTA AZADA+MARTILLO 160
14	M304194011	ROTORE DX + MAZZA*20 GF185	ROTOR + HAMMER 185	MESSERHAL ROTOR+SCHLEGEL 185	ROTOR PORTE COUTEAUX+MART. 185	ROTOR PORTA AZADA+MARTILLO 185
15	M304214011	ROTORE DX + MAZZA*20 GF210	ROTOR + HAMMER 210	MESSERHAL ROTOR+SCHLEGEL 210	ROTOR PORTE COUTEAUX+MART. 210	ROTOR PORTA AZADA+MARTILLO 210
16	M304154021	ROTORE DX + COLT*18 GF160	ROTOR + KNIFE 160	MESSERHAL ROTOR+MESSER 160	ROTOR PORTE COUTEAUX+COUT. 160	ROTOR PORTA AZADA+CUCHILLAS 160
17	M304194021	ROTORE DX + COLT*18 GF185	ROTOR + KNIFE 185	MESSERHAL ROTOR+MESSER 185	ROTOR PORTE COUTEAUX+COUT. 185	ROTOR PORTA AZADA+CUCHILLAS 185
18	M304214021	ROTORE DX + COLT*18 GF210	ROTOR + KNIFE 210	MESSERHAL ROTOR+MESSER 210	ROTOR PORTE COUTEAUX+COUT. 210	ROTOR PORTA AZADA+CUCHILLAS 210
19	M067154111	ROTORE SX + MAZZA*20 GF160	ROTOR + HAMMER 160	MESSERHAL ROTOR+SCHLEGEL 160	ROTOR PORTE COUTEAUX+MART. 160	ROTOR PORTA AZADA+MARTILLO 160
20	M067194111	ROTORE SX + MAZZA*20 GF185	ROTOR + HAMMER 185	MESSERHAL ROTOR+SCHLEGEL 185	ROTOR PORTE COUTEAUX+MART. 185	ROTOR PORTA AZADA+MARTILLO 185
21	M067214111	ROTORE SX + MAZZA*20 GF210	ROTOR + HAMMER 210	MESSERHAL ROTOR+SCHLEGEL 210	ROTOR PORTE COUTEAUX+MART. 210	ROTOR PORTA AZADA+MARTILLO 210
22	M067154121	ROTORE SX + COLT*18 GF160	ROTOR + KNIFE 160	MESSERHAL ROTOR+MESSER 160	ROTOR PORTE COUTEAUX+COUT. 160	ROTOR PORTA AZADA+CUCHILLAS 160
23	M067194121	ROTORE SX + COLT*18 GF185	ROTOR + KNIFE 185	MESSERHAL ROTOR+MESSER 185	ROTOR PORTE COUTEAUX+COUT. 185	ROTOR PORTA AZADA+CUCHILLAS 185
24	M067214121	ROTORE SX + COLT*18 GF210	ROTOR + KNIFE 210	MESSERHAL ROTOR+MESSER 210	ROTOR PORTE COUTEAUX+COUT. 210	ROTOR PORTA AZADA+CUCHILLAS 210

MASCHIO - per versione destra
for right version

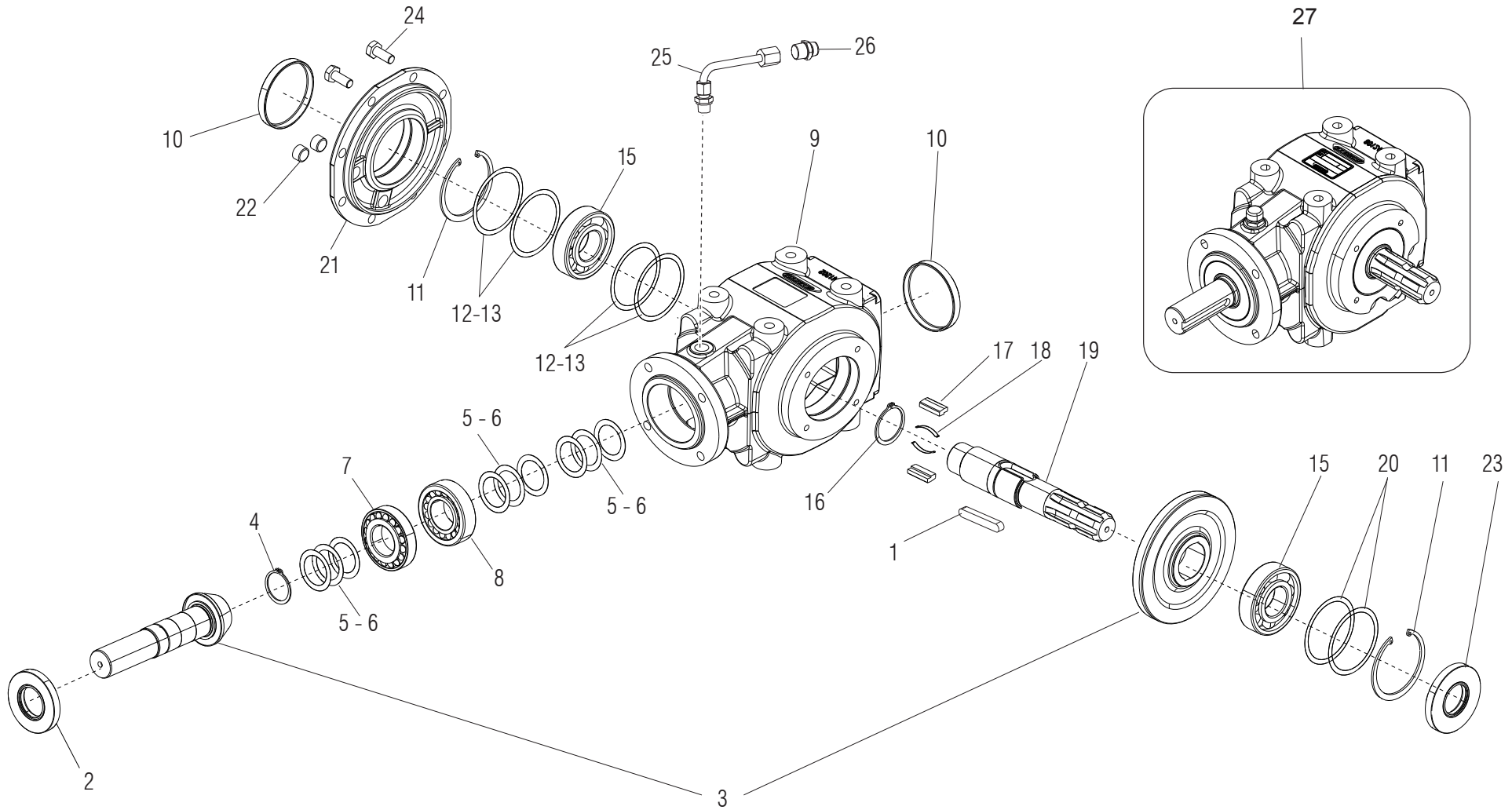

MOLTIPLICATORE 540 rpm - Maschio per versione destra / GEARBOX 540 rpm - Maschio for right version

TAV. 070

Pos.	Cod.	Descrizione	Description	Benennung	Description	Description
1	F02150106	LINGUETTA 10X 8X 65 U6604A	KEY 10X8X65	FEDER 10X8X65	CLAVETTE 10X8X65	LLAVE 10X8X65
2	F03010088	ANELLO T.AS.35X 72X10 D3760NBR	OIL SEAL 35X72X10	OELABDICHTUNG 35X72X10	PARA-HUILLE 35X72X10	PARA-ACEITE 35X72X10
3	M30400203	COPPIA CONICA	BEVEL GEAR PAIR	KEGELRITZELSATZ	COUPLE CONIQUE	PAR CONICO
4	F02050146	SEEGER	SEEGER RING	SEEGERRING	BAGUE SEEGER	ANILLO
5	T24001216	SPESSORE 0,5	THICKNESS	DISTANZSTUECK	EPAISSEUR	RENFUERZOS
6	T24001215	SPESSORE 0,25	THICKNESS	DISTANZSTUECK	EPAISSEUR	RENFUERZOS
7	F04050014	CUSCINETTO 30207	BEARING 30207	LAGER 30207	ROULEMENT 30207	COJINETE 30207
8	F04050070	CUSC.D35 D72 T24,25 32207	BEARING 32207	LAGER 32207	ROULEMENT 32207	COJINETE 32207
9	T24001202	CORPO RIDUTTORE	GEARBOX	WECHSELGETRIEBEGEHAUSE	BOITE DE VITESSE	CAJA CAMBIO
10	F03011026	PARAOLIO TAPPO CIECO 80X10	CAP 80X10	DECKEL 80X10	BOUCHON 80X10	CORCHO 80X10
11	F02050425	ANELLO E. DI 80X 2,5 U7437 C70	SEEGER RING D.80	SEEGERRING D.80	BAGUE SEEGER D.80	ANILLO SEEGER D.80
12	T24001214	SPESSORE 0,15	THICKNESS	DISTANZSTUECK	EPAISSEUR	RENFUERZOS
13	T24001213	SPESSORE 0,25	THICKNESS	DISTANZSTUECK	EPAISSEUR	RENFUERZOS
15	F04010216	CUSC.D35 D80 B21 6307	BEARING 6307	LAGER 6307	ROULEMENT 6307	COJINETE 6207
16	F02050179	SEEGER D.42 UNI7435	ELASTIC RING D.42 UNI7435	RING D.42 UNI7435	BAGUE ELASTIQUE D.42 UNI7435	ANILLO D.42 UNI7435
17	T24001204	LINGUETTA	PARALLEL KEY	FEDER	CLAVETTE	LLAVE
18	T24001203	MOLLA	SPRING	FEDER	RESSORT	MUELLE
19	M30400202	ALBERO	SHAFT	ZENTRALWELLE	ARBRE	ARBOL
20	M07400223	SPESSORE 2,5	THICKNESS	DISTANZSTUECK	EPAISSEUR	RENFUERZOS
21	T24001208	FLANGIA CORPO TRASMISSIONE	GEARBOX COVER	GETRIEBEBEDECKEL	COUVERCLE BOITE A VITESSES	TAPA CAJA CAMBIO
22	F03150719	TAPPO SCARICO OLIO	OIL OUTLET PLUG	OELABLASSPFROPFEN	BOUCHON DE VIDANGE HUILE TAPON	DESCARGADO ACEITE
23	F03010265	ANELLO T.AS 35X 80X10 D3760NBR	RING T.AS 35X80X10 D3760 NBR	SCHUTZRING 35X80X10 D3760 NBR	BAGUE T.AS 35X 80X10 D3760 NBR	INEL T.AS 35X80X10 D3760 NBR
24	F01010244	VITE M10X1,25 X 25 5740 8.8 BG	BOLT M 10X25	SCHRAUBE M 10X25	VIS M 10X25	TORNILLO M 10X25
25	M07400216	PROLUNGA*SFIATO 90°	BREATHER PLUG 90°	ENTLUEFTERSTOPFEN 90°	BOUCHON DE SOUPIRAIL 90°	TAPON RESPIRADERO 90°
26	F03150718	TAPPO 3/8" GAS	OIL BREATHER PLUG	OELENTLUEFTERSTOPFEN	BOUCHON D'HUILE SOUPIRAIL	TAPON ACEITE
27	M30400201	MOLTIPLICATORE	GEARBOX	WECHSELGETRIEBEGEHAUSE	BOITE DE VITESSE	CAJA CAMBIO

**BONDIOLI - per versione destra
for right version**

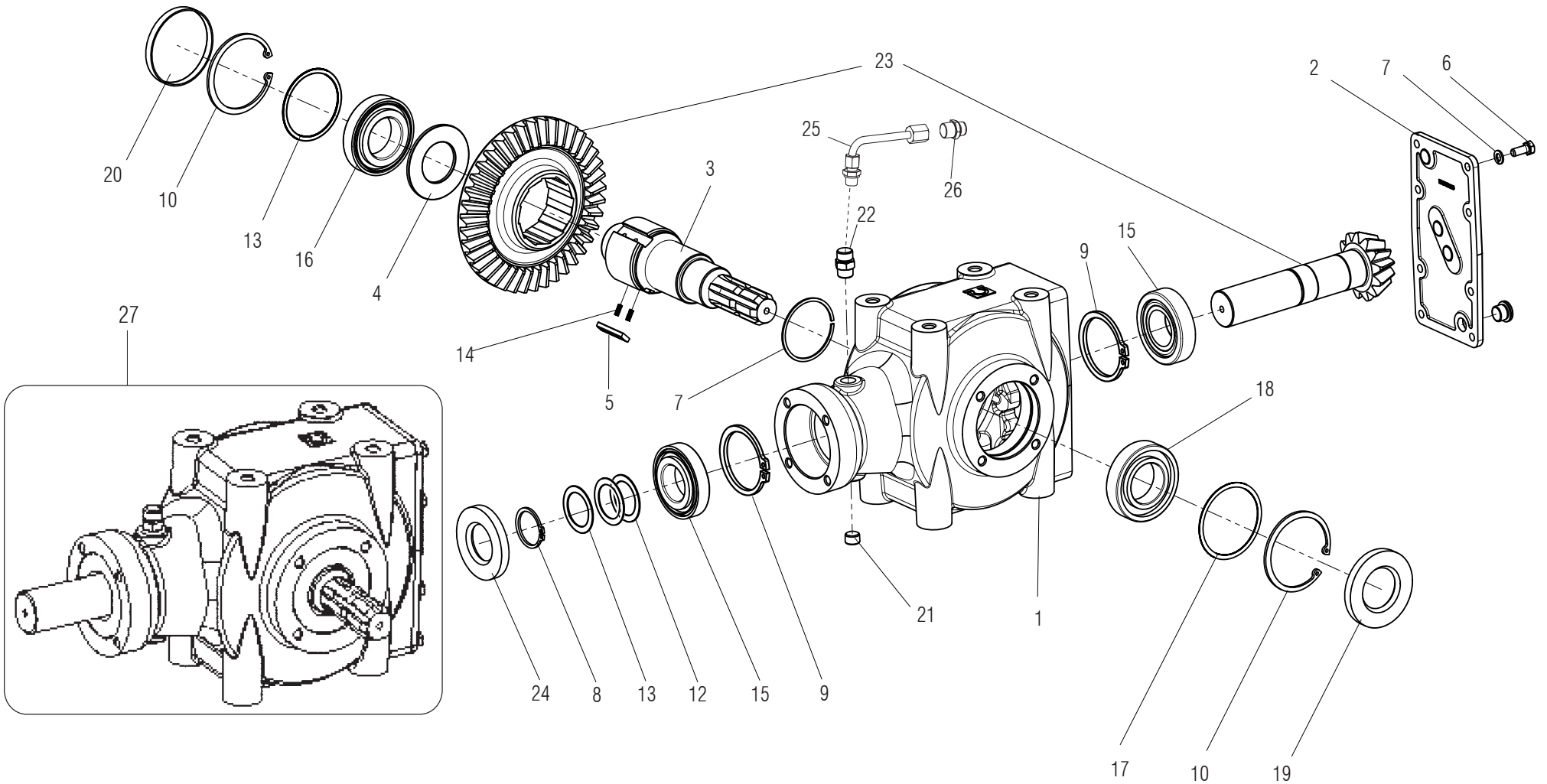

MOLTIPLICATORE 540 rpm - Bondioli per versione destra/ GEARBOX 540 rpm - Bondioli for right version

TAV. 080

Pos.	Cod.	Descrizione	Description	Benennung	Description	Description
1	M30500100	SCATOLA 2061 G25 BP	GEARBOX	WECHSELGETRIEBEGEHAEUSE	BOITE DE VITESSE	CAJA CAMBIO
2	M30500108	KIT COPXSCAT 2061	GEARBOX COVER	GETRIEBEDECKEL	COUVERCLE BOITE A VITESSES	TAPA CAJA CAMBIO
3	M30500101	ALBERO AS.X 2061 BP	SHAFT	ZENTRALWELLE	ARBRE	ARBOL
4	M30500103	DIST.DI SPALLAMENTO	SPACER	DISTANZSTUECK	ENTRETOISE	DISTANCIADOR
5	M30500104	PIASTRI.RL L=40X2061	PLATE	PLATTE	PLAQUETTE	PLAQUITA
6	F01020436	VITE M 8X1,25X20 U5739 8.8 PL	SCREW M8X1,25X20 U5929 8.8 BR	SCHRAUBE M 8X20	VIS M 8X20	TORNILLO M 8X20
7	F01480099	ROS.G 8,4X14,4X2,7 EX.C70 ZN	GROWER WASHER D.8	SCHLEIBE GROWER D.8	RONDELLE GROWER D.8	ARANDELA GROWER D.8
8	F02050147	ANELLO E.ES.35X2,5	ELASTIC RING 35X2,5	ELASTIQUE RING UNI	BAGUE	ANILLO E.ES.35X2,5
9	F02050403	ANELLO E. DI 72X 2,5 U7437 C70	SEEGER RING E.72X2,5 U7437 C70	SEEGERING E. 72X 2,5 U7437 C70	SEEGER E. 72X 2,5 U7437 C70	ANILLO E. 72X 2,5 U7437 C70
10	F02050425	ANELLO E. DI 80X 2,5 U7437 C70	SEEGER RING D.80	SEEGERRING D.80	BAGUE SEEGER D.80	ANILLO SEEGER D.80
12	M30500105	ANELLI SP.35,2	REINFORCEMENTS	VERSTAERKERUNGEN	RENFORTS	RENFUERZOS
13	M30500102	DIST.D.35,2X48,3X4	SPACER D.35,2X48,3X4	DISTANZSTUECK D.35,2X48,3X4	ENTRETOISE D.35,2X48,3X4	DISTANCIADOR D.35,2X48,3X4
14	M50400905	MOLLA PER RUOTA LIBERA	SPRING	FEDER	RESSORT	RESORTE
15	F04050014	CUSC.D35 D72 T18,25 30207	BEARING D35 D72 T18,25 30207	LAGER 30207	ROULEMENT 30207	COJINETE 30207
16	F04050017	CUSC.D40 D80 T19,75 30208	BEARING D40 D80 T19,75 30208	LAGER D40 D80 T19,75	ROULEMENT D40 D80 T19,75 302	COJINETE D40 D80 T19,75 3020
17	M30500106	ANELLI SP. 69,3	REINFORCEMENTS	VERSTAERKERUNGEN	RENFORTS	RENFUERZOS
18	F04010180	CUSC.D40 D80 B18 6208	BEARING D40 D80 B18 6208	LAGER 6208	ROULEMENT 6208	COJINETE 6208
19	F03010277	ANELLO T.AS 40X 80X10 D3760NBR	OIL SEAL 40X80X10	OELABDICHTUNG 40X80X10	BOURAGE 40X80X10	JUNTA DE ACEITE 40X80X10
20	F03011026	TAPPO CHIUSURA D=80 X 10 GA	CAP 80X10	DECKEL 80X10	BOUCHON 80X10	CORCHO 80X10
21	F03150719	TAPPO 3/8 GAS	CAP	DECKEL	BOUCHON	CORCHO
22	F03151040	PROLUNGA 3/8"M-F L=35	NIPPLE EXTENSION	RALLONGE 3/8"	VERLAENGERUNG	PROLONGA RACOR
23	M30500107	COPPIA CON.X2061 RL	BEVEL GEAR PAIR	KEGELRITZELSATZ	COUPLE CONIQUE	PAR CONICO
24	F03010265	ANELLO T.AS 35X 80X10 D3760NBR	RING T.AS 35X80X10 D3760 NBR	SCHUTZRING 35X80X10 D3760 NBR	BAGUE T.AS 35X 80X10 D3760 NBR	INEL T.AS 35X80X10 D3760 NBR
25	M07400216	PROLUNGA*SFIATO 90°	BREATHER PLUG 90°	ENTLUEFTERSTOPFEN 90°	BOUCHON DE SOUPIRAIL 90°	TAPON RESPIRADERO 90°
26	F03150718	TAPPO 3/8" GAS	OIL BREATHER PLUG	OELENTLUEFTERSTOPFEN	BOUCHON D'HUILE SOUPIRAIL	TAPON ACEITE
27	M30400205	SCATOLA MOLTIPL.540 BONDIOLI	COMPLETE GEARBOX	WECHSELGETRIEBE	BOITE DE VITESSE	CAJA CAMBIO COMPLETA

MASCHIO - per versione sinistra
for left version

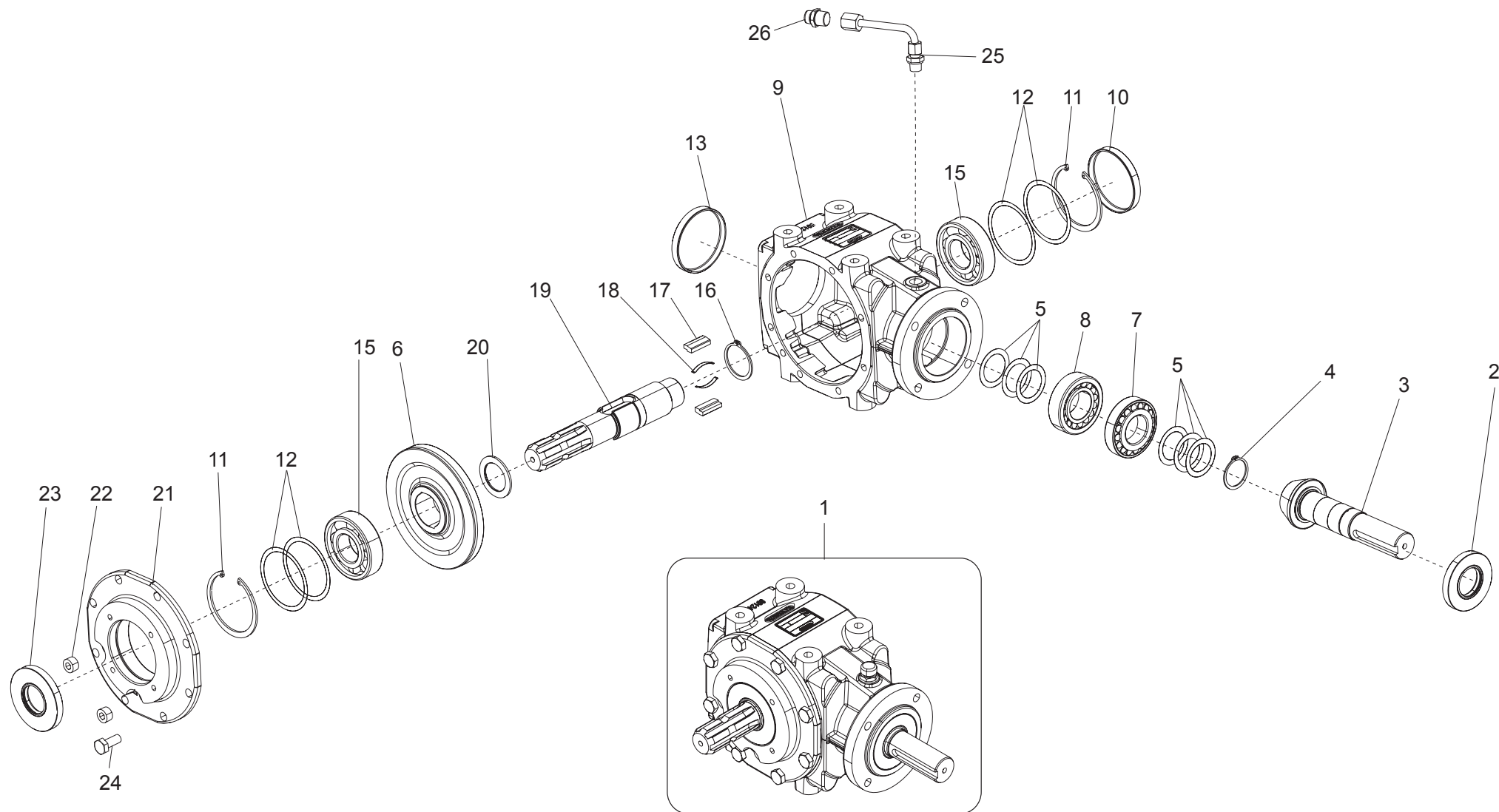

MOLTIPLICATORE 540 rpm - Maschio per versione sinistra / GEARBOX 540 rpm - Maschio for left version

TAV. 090

Pos.	Cod.	Descrizione	Description	Benennung	Description	Description
1	M07400201	MOLTIPLICATORE	GEARBOX	WECHSELGETRIEBEGEHAUSE	BOITE DE VITESSE	CAJA CAMBIO
2	F03010088	ANELLO T.AS.35X 72X10 D3760NBR	OIL SEAL 35X72X10	OELABDICHTUNG 35X72X10	PARA-HUILLE 35X72X10	PARA-ACEITE 35X72X10
3	M07400003	A.PIGN.Z12 M4.35	BEVEL PINION	KEGELRITZEL	PIGNON CONIQUE	PINON CONICO
4	M07400004	SEEGER 35X33X2.5	SEEGER RING 35X33X2.5	SEEGERRING D 35X33X2.5	BAGUE SEEGER D 35X33X2,5	ANILLO D 35X33X2,5
5	M07400002	KIT SPES.0,3/4/5	REINFORCEMENTS	VERSTAERKERUNGEN	RENFORTS	RENFUERZOS
6	M07400007	CORONA*Z36 M4.35	RING BEVEL GEAR	KEGELRADKRANZ	COURONNE CONIQUE	CORONA CONICA
7	F04050014	CUSCINETTO 30207	BEARING 30207	LAGER 30207	ROULEMENT 30207	COJINETE 30207
8	F04050070	CUSC.D35 D72 T24,25 32207	BEARING 32207	LAGER 32207	ROULEMENT 32207	COJINETE 32207
9	M03400020	CORPO RIDUTTORE	GEARBOX	WECHSELGETRIEBEGEHAUSE	BOITE DE VITESSE	CAJA CAMBIO
10	F03011026	PARAOLIO TAPPO CIECO 80X10	CAP 80X10	DECKEL 80X10	BOUCHON 80X10	CORCHO 80X10
11	F02050425	ANELLO E. DI 80X 2,5 U7437 C70	SEEGER RING D.80	SEEGERRING D.80	BAGUE SEEGER D.80	ANILLO SEEGER D.80
12	M07400006	KIT SPESSORI	THICKNESS KIT	DISTANZSTUECK	KIT EPAISSEUR	KIT ESPESORES
13	F03011026	PARAOLIO TAPPO CIECO 80X10	CAP 80X10	DECKEL 80X10	BOUCHON 80X10	CORCHO 80X10
15	F04010216	CUSC.D35 D80 B21 6307	BEARING 6307	LAGER 6307	ROULEMENT 6307	COJINETE 6207
16	M03400007	SEEG.42X39,5X1,75	ELASTIC RING 42X39,5X1,75	RING 42X39,5X1,75	BAGUE ELASTIQUE 42X39,5X1,75	ANILLO UNI 42X39,5X1,75
17	M07400005	LINGUETTA	PARALLEL KEY	FEDER	CLAVETTE	LLAVE
18	M03400009	MOLLA X CHIAVET.	SPRING	FEDER	RESSORT	MUELLE
19	M07400001	1"3/8 Z6 ALBERO*	SHAFT	ZENTRALWELLE	ARBRE	ARBOL
20	M03400008	SPESS. 48X35,3X1	THICKNESS 48X35,3X1	DISTANZSTUECK 48X35,3X1	EPAISSEUR 48X35,3X1	ESPEJOR 48X35,3X1
21	T24001208	FLANGIA CORPO TRASMISSIONE	GEARBOX COVER	GETRIEBEBECKEL	COUVERCLE BOITE A VITESSES	TAPA CAJA CAMBIO
22	M29100112	TAPPO SCARICO OLIO	OIL OUTLET PLUG	OELABLASSPFROPFEN	BOUCHON DE VIDANGE HUILE TAPON	DESCARGADO ACEITE
23	F03010265	ANELLO T.AS 35X 80X10 D3760NBR	RING T.AS 35X80X10 D3760 NBR	SCHUTZRING 35X80X10 D3760 NBR	BAGUE T.AS 35X 80X10 D3760 NBR	INEL T.AS 35X80X10 D3760 NBR
24	F01010244	VITE M10X1,5 X 25 5739 8.8 BR	BOLT M 10X25	SCHRAUBE M 10X25	VIS M 10X25	TORNILLO M 10X25
25	M07400216	PROLUNGA*SFIATO 90°	BREATHER PLUG 90°	ENTLUEFTERSTOPFEN 90°	BOUCHON DE SOUPIRAIL 90°	TAPON RESPIRADERO 90°
26	F03150718	TAPPO 3/8" GAS CON SFIATO	OIL BREATHER PLUG	OELENTLUEFTERSTOPFEN	BOUCHON D'HUILE SOUPIRAIL	TAPON ACEITE

**BONDIOLI - per versione sinistra
for left version**

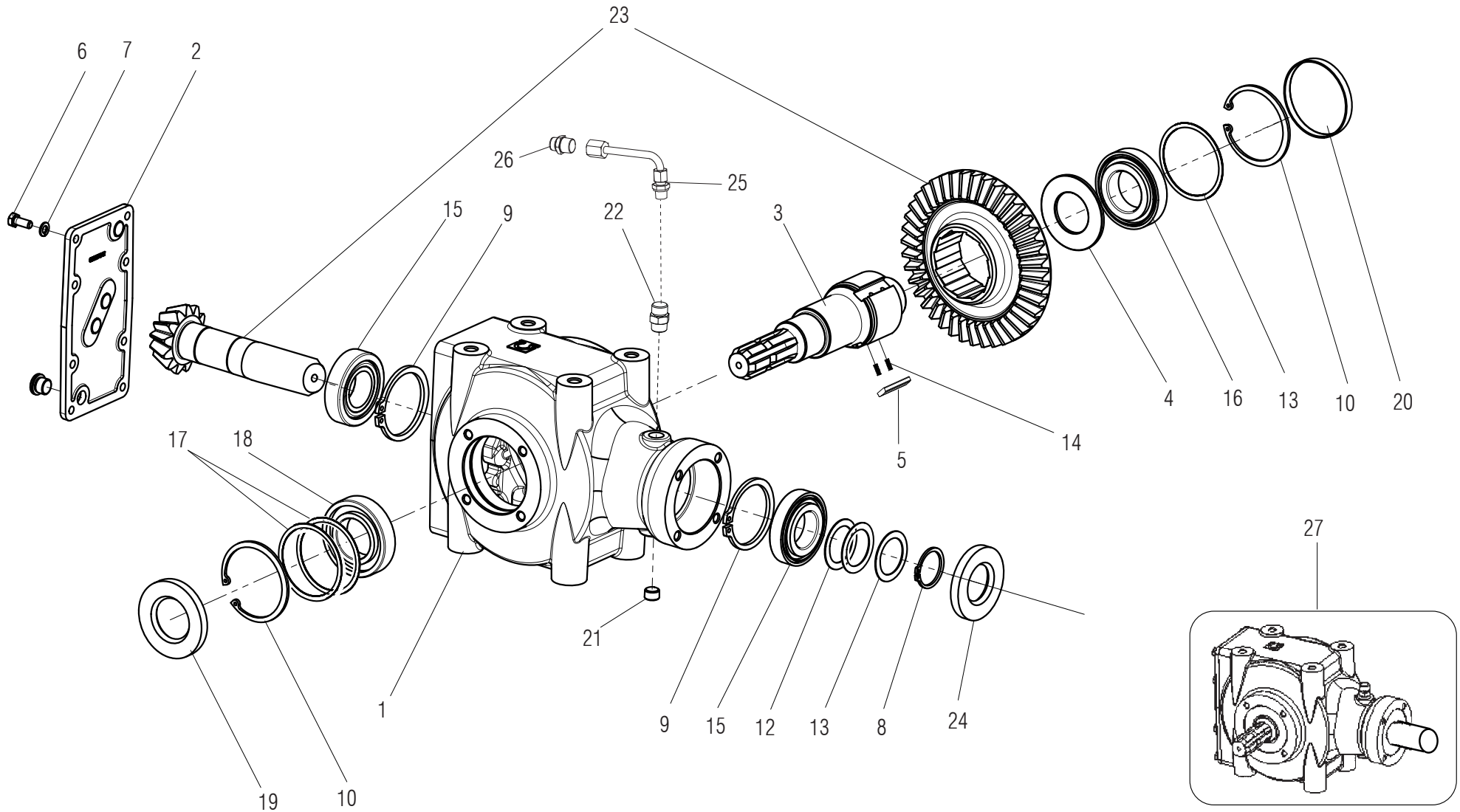

MOLTIPLICATORE 540 rpm - Bondioli per versione sinistra / GEARBOX 540 rpm - Bondioli for left version

TAV. 100

Pos.	Cod.	Descrizione	Description	Benennung	Description	Description
1	M30500158	SCATOLA 2061 G25 BP	GEARBOX	WECHSELGETRIEBEGEHAEUSE	BOITE DE VITESSE	CAJA CAMBIO
2	M30500108	KIT COPXSCAT 2061	GEARBOX COVER	GETRIEBEDECKEL	COUVERCLE BOITE A VITESSES	TAPA CAJA CAMBIO
3	M30500152	ALBERO AS.X 2061 BP	SHAFT	ZENTRALWELLE	ARBRE	ARBOL
4	M30500103	DIST.DI SPALLAMENTO	SPACER	DISTANZSTUECK	ENTRETOISE	DISTANCIADOR
5	M30500104	PIASTRI.RL L=40X2061	PLATE	PLATTE	PLAQUETTE	PLAQUITA
6	F01020436	VITE M 8X1,25X20 U5739 8.8 PL	SCREW M8X1,25X20 U5929 8.8 BR	SCHRAUBE M 8X20	VIS M 8X20	TORNILLO M 8X20
7	F01480099	ROS.G 8,4X14,4X2,7 EX.C70 ZN	GROWER WASHER D.8	SCHLEIBE GROWER D.8	RONDELLE GROWER D.8	ARANDELA GROWER D.8
8	F02050147	ANELLO E. DE 35X2,5	ELASTIC RING 35X2,5	ELASTIQUE RING UNI	BAGUE	ANILLO E.ES.35X2,5
9	F02050403	ANELLO E. DI 72X 2,5 U7437 C70	SEEGER RING E.72X2,5 U7437 C70	SEEGERING E. 72X 2,5 U7437 C70	SEEGER E. 72X 2,5 U7437 C70	ANILLO E. 72X 2,5 U7437 C70
10	F02050425	ANELLO E. DI 80X 2,5 U7437 C70	SEEGER RING D.80	SEEGERRING D.80	BAGUE SEEGER D.80	ANILLO SEEGER D.80
12	M30500105	ANELLI SP.35,2	REINFORCEMENTS	VERSTAERKERUNGEN	RENFORTS	RENFUERZOS
13	M30500102	DIST.D.35,2X48,3X4	SPACER D.35,2X48,3X4	DISTANZSTUECK D.35,2X48,3X4	ENTRETOISE D.35,2X48,3X4	DISTANCIADOR D.35,2X48,3X4
14	M50400905	MOLLA PER RUOTA LIBERA	SPRING	FEDER	RESSORT	RESORTE
15	F04050014	CUSC.D35 D72 T18,25 30207	BEARING D35 D72 T18,25 30207	LAGER 30207	ROULEMENT 30207	COJINETE 30207
16	F04050017	CUSC.D40 D80 T19,75 30208	BEARING D40 D80 T19,75 30208	LAGER D40 D80 T19,75	ROULEMENT D40 D80 T19,75 302	COJINETE D40 D80 T19,75 3020
17	M30500106	ANELLI SP. 69,3	REINFORCEMENTS	VERSTAERKERUNGEN	RENFORTS	RENFUERZOS
18	F04010180	CUSC.D40 D80 B18 6208	BEARING D40 D80 B18 6208	LAGER 6208	ROULEMENT 6208	COJINETE 6208
19	F03010277	ANELLO T.AS 40X 80X10 D3760NBR	OIL SEAL 40X80X10	OELABDICHTUNG 40X80X10	BOURAGE 40X80X10	JUNTA DE ACEITE 40X80X10
20	F03011026	TAPPO CHIUSURA D=80 X 10 GA	CAP 80X10	DECKEL 80X10	BOUCHON 80X10	CORCHO 80X10
21	F03150719	TAPPO 3/8 GAS	CAP	DECKEL	BOUCHON	CORCHO
22	F03151040	PROLUNGA 3/8" M-F L=35	NIPPLE EXTENSION	VERLAENGERUNG	RALLONGE 3/8"	PROLONGA RACOR
23	M30500159	COPPIA CON.X2061 RL	BEVEL GEAR PAIR	KEGELRITZELSATZ	COUPLE CONIQUE	PAR CONICO
24	F03010265	ANELLO T.AS 35X 80X10 D3760NBR	RING T.AS 35X80X10 D3760 NBR	SCHUTZRING 35X80X10 D3760 NBR	BAGUE T.AS 35X 80X10 D3760 NBR	INEL T.AS 35X80X10 D3760 NBR
25	M07400216	PROLUNGA*SFIATO 90°	BREATHER PLUG 90°	ENTLUEFTERSTOPFEN 90°	BOUCHON DE SOUPIRAIL 90°	TAPON RESPIRADERO 90°
26	F03150718	TAPPO 3/8" GAS CON SFIATO	GAS BREATHER PLUG 3/8"	OELENTLUEFTERSTOPFEN	BOUCHON D'HUILE SOUPIRAIL	TAPON ACEITE
27	M07400203	MOLTIPLICATORE BONDIOLI	COMPLETE GEARBOX	WECHSELGETRIEBE	BOITE DE VITESSE	CAJA CAMBIO COMPLETA

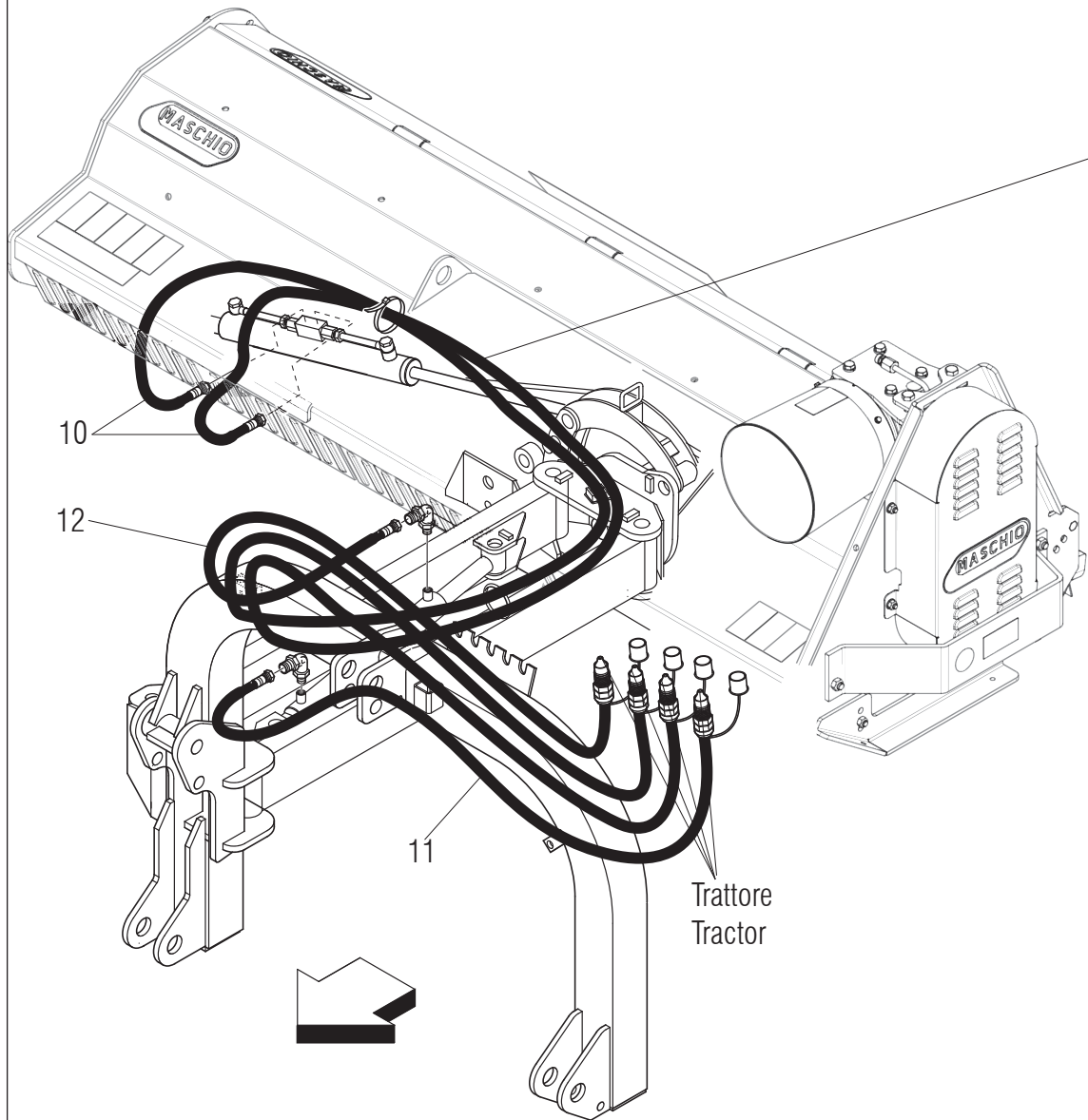

**KIT RIDUZIONE TUBI IDR.
HYDRAULIC TUBE
REDUCTION KIT**

Cilindri
Cylinders

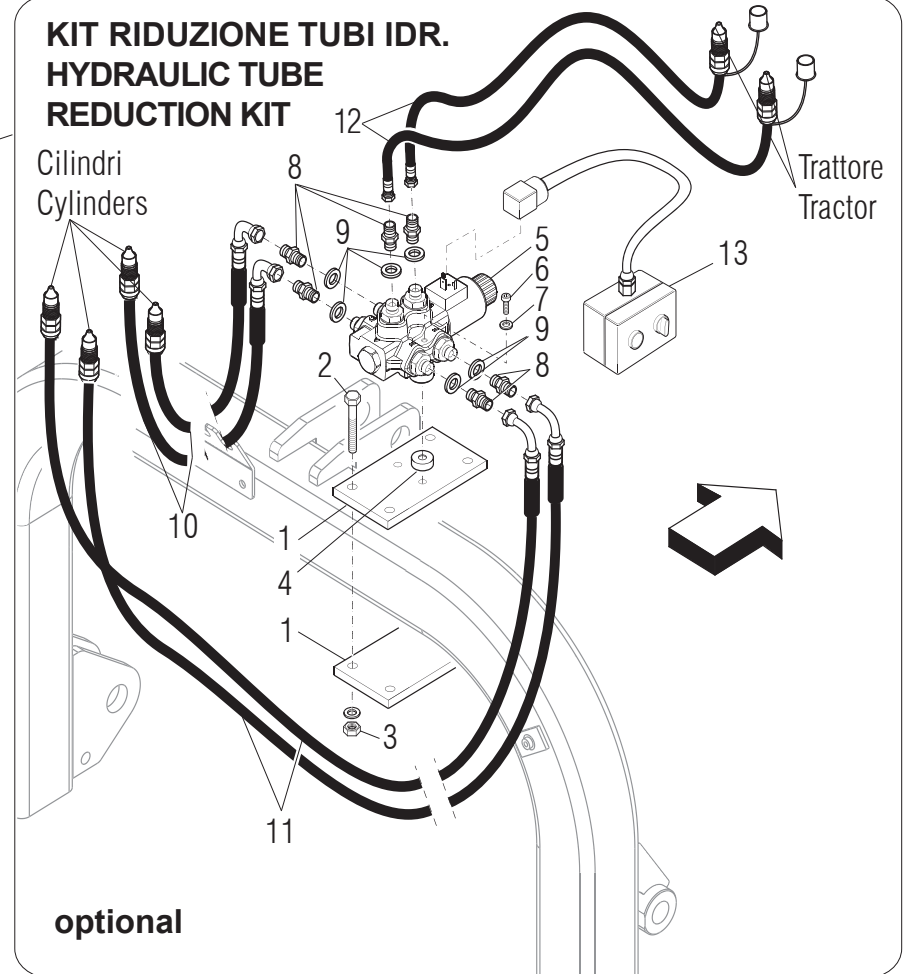

optional

IMPIANTO IDRAULICO - HYDRAULIC PLANT

TAV. 110

Pos.	Cod.	Descrizione	Description	Benennung	Description	Description
1	M07400805	STAFFA PORTA DEVIATORE	BRACKET	PLATTE	PLAQUETTE	PLAQUITA
2	F01010038	VITE M10X1,25X140 5738 8.8 ZN	BOLT M10X1,25X140 5738 8.8 ZN	SCHAR.M10X1,25X140 5738 8.8 ZN	VIS M10X1,25X140 5738 8.8 ZN	TORN. M10X1,25X140 5738 8.8 ZN
3	F01220034	DADO M10X1,25 D980 8 ZN	NUT M10X1,25 D980 8 ZB	MUTT.M10X1,25 D980 8 ZB	ECRO.M10X1,25 D980 8 ZB	TUER.M10X1,25 D980 8 ZB
4	M33100599	DISTANZIALE PROTEZIONE ERP.ZN	SPACER	DISTANZSTUECK	ENTRETOISE	DISTANCIADOR
5	F03151042	DEVIATORE A 6 VIE 2 POSIZIONI	DISTRIBUTOR	VERTEILER	DISTRIBUTEUR	DISTRIBUIDOR
6	F01040069	VITE M6X1X55 U5931 8.8 ZN	BOLT M 6X1X55 U5739 8.8 ZB	SCHRAUBE M 6X1X55	VIS M 6X1X55	TORNILLO M 6X1X55
7	F01480088	ROS.G 6,4X12,4X2 FLZNNC-240H	GROWER WASHER D.6	SCHEIBE GROWER D.6	RONDELLE GROWER D.6	ARANDELA GROWER D.6
8	F03150310	NIPPLO MM CIL-CIL 3/8-1/4 ZN	NIPPLE CYL.MALE3/8-1/4 ZN	NIPPELZYL.3/8-1/4 ZN	NIPPLE MALE CYL.3/8-1/4 ZN	NIPL MACHO CIL.3/8-1/4 ZN
9	F03100023	ROS. 17 X23X1,5 RAME -3/8"	WASHER 17X23X1,5	SCHEIBE 17X23X1,5	RONDELLE 17X23X1,5	ARANDELA 17X23X1,5
10	F03060012	KIT TUBAZ.IDR.X SILVA E KIT GF	HYDR.PIPE KIT SILVA E KIT GF	KIT HYDRAUL. ROHR	KIT TUBE HYDRAUL.	KIT TUBO HYDRAULICO
11	F03060013	KIT TUBAZ.IDR.X KIT GF	HYDRAULIC PIPE KIT GF	KIT HYDRAUL. ROHR	KIT TUBE HYDRAUL.	KIT TUBO HYDRAULICO
12	F03060011	KIT TUBAZ.IDR.X CP	HYDRAULIC PIPE KIT CP	KIT HYDRAUL. ROHR	KIT TUBE HYDRAUL.	KIT TUBO HYDRAULICO
13	M58100872	COMANDO ELETTRICO 12V DC	ELECTRIC CONTROL	ELEKTRISCHER ANTRIEB	COMMANDE ELECTRIQUE	ACCIONAMIENTO ELECTRICO

TAV. 120

WALTERSCHEID

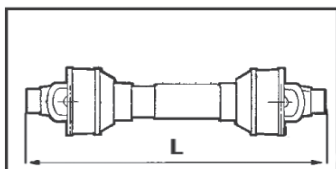

F08011608 L=1934 ; 1 3/8" Z6

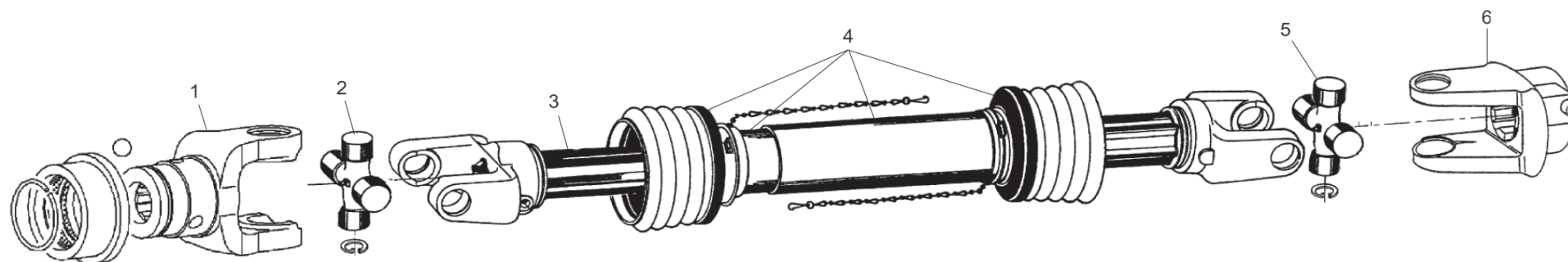

CARDANO WALTERSCHEID / WALTERSCHEID CARDAN SHAFT

TAV. 120

Pos.	Cod.	Descrizione	Description	Benennung	Description	Description
1	F08011608	CARD.GKN	UNIVERSAL P T O SHAFT	GELENKWELLE	ARBRE A CARDAN	ARBOL CARDANICO
	F08000003	FORCEL.13/8 Z6	LINKAGE FORK 1" 3/8 Z6	GABELSTUECK 1" 3/8 Z6	FOURCHE ATTELAGE 1" 3/8 Z6	HORQUILLA ATAQUE 1" 3/8 Z6
2	F08010683	CROCIERA COMPLETA W2300	SPIDER ASSY	GELENKKREUZ KOMPL.	CROISIERE COMPL.	CRUCETA COMPL.
3	F08010814	FORCELLA + TUBO PROFILATO INT.	YOKE WITH EXTERNAL PIPE	GABELSTUECK	FOURCHE ATTELAGE	HORQUILLA ATAQUE
4	F08010851	PROTEZIONE COMPLETA	PROTECTION ASSY	KOMPL. SCHUTZ	PROTECTION COMPL.	PROTECCION COMPL.
5	F08010544	FORCELLA CON TUBO ESTERNO SALD	YOKE WITH EXTER. WELDING PIPE	GABELSTUECK	FOURCHE ATTELAGE	HORQUILLA ATAQUE
6	F08010457	FORCELLA COMPLETA DI PULSANTE	LINKAGE FORK	GABELSTUECK	FOURCHE ATTELAGE	HORQUILLA ATAQUE

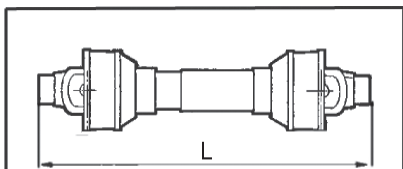

F08011696 L=2047 3/8" Z6

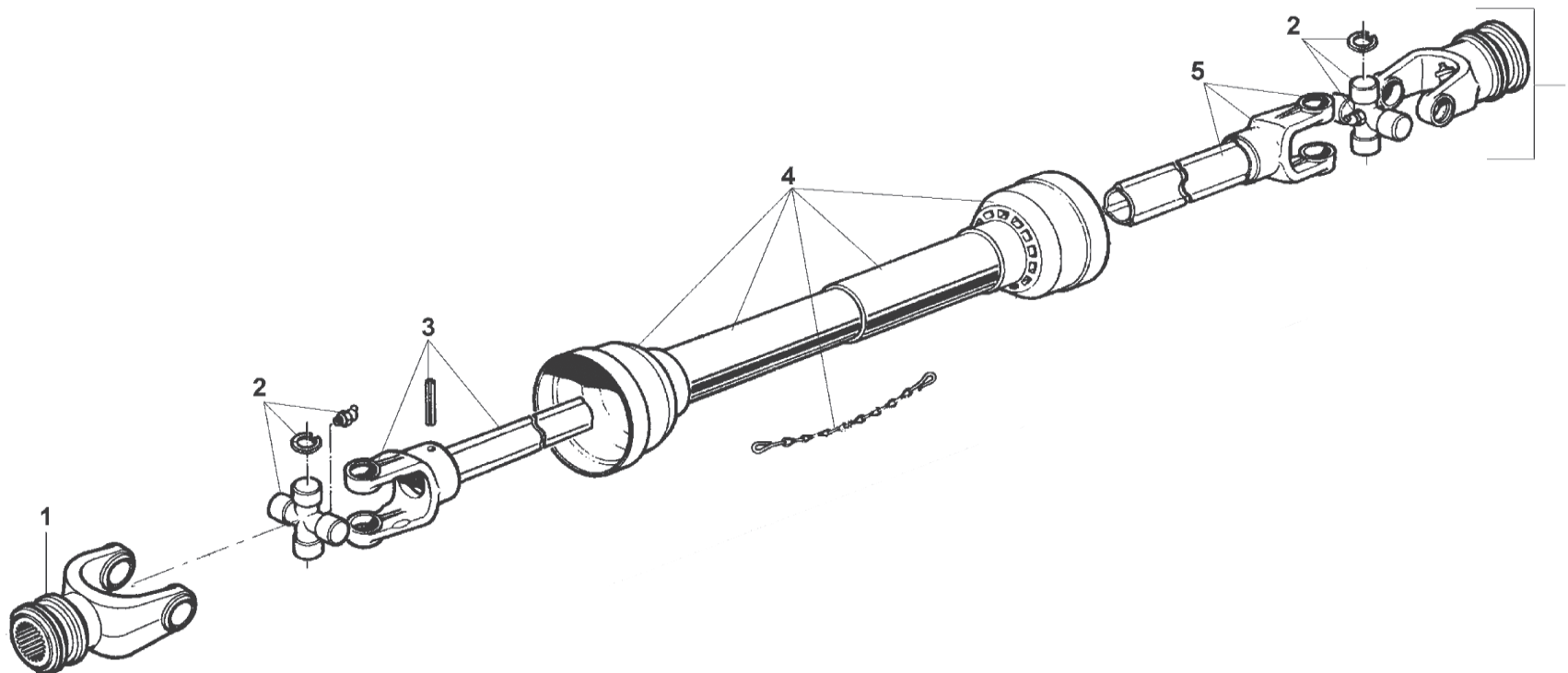

CARDANO BONDIOLI / BONDIOLI CARDAN SHAFT

TAV. 130

Pos.	Cod.	Descrizione	Description	Benennung	Description	Description
1	F08011696	CARD.GKN	UNIVERSAL P T O SHAFT	GELENKWELLE	ARBRE A CARDAN	ARBOL CARDANICO
	F08010167	FORCELLA COMPLETA	LINKAGE FORK	GABELSTUECK	FOURCHE ATTELAGE	HORQUILLA ATAQUE
2	F08010678	CROCIERA COMPLETA	SPIDER ASSY	GELENKKREUZ KOMPL.	CROISIERE COMPL.	CRUCETA COMPLETA
3	F08012159	FORC.106+TUBO INT.1650+SPINA*	FORK WITH INTERNAL PIPE	GABELST. + INNENROHR	FOURCHE AVEC TUBE INTERIEUR	HORQUILLA + TUBO INTERIOR
4	F08012157	PROT. COMPLETA 106 L.1810	PROTECTION ASSY	KOMPL. SCHUTZ	PROTECTION COMPL.	PROTECCION COMPL.
5	F08012158	FORC.106+TUBO EST.1650+SPINA*	FORK WITH EXTERNAL PIPE	GABELST. + AUSSENROHR	FOURCHE AVEC TUBE EXT.	HORQUILLA + TUBO EXT.

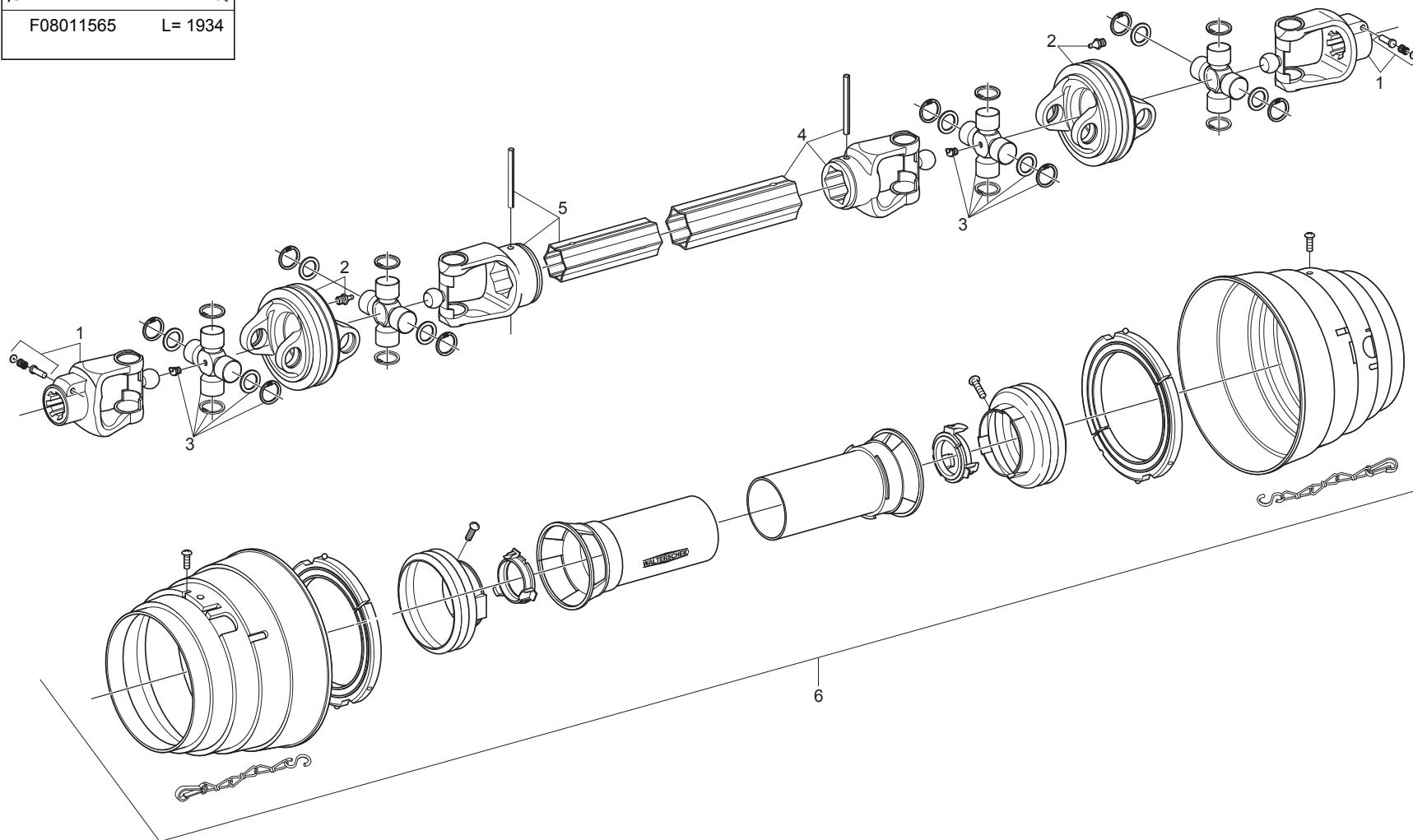
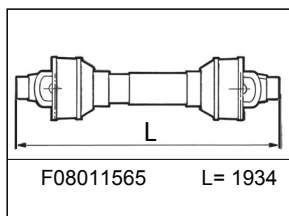

CARDANO OMOCINETICO WALTERSCHEID / WALTERSCHEID CONSTANT VELOCITY PTO SHAFT

TAV. 140

Pos.	Cod.	Descrizione	Description	Benennung	Description	Description
	F08011565	CARD.GKN	UNIVERSAL P T O SHAFT	ARBRE A CARDAN	GELENKWELLE	ARBOL CARDANICO
1	F08010463	FORCELLA COMPLETA DI PULS	LINKAGE FORK+PUSHBUTTON	GABELSTUECK+DRUCKKNOP	FOURCHE ATTELAGE+POUSSOIR	HORQUILLA ATAQUE+PULSADOR
2	F08010223	FORCELLA DOPPIA + INGRASS	DOUBLEYOKE+GREASENIPPLE	DOPPELGABEL+SCHMIERNIPPEL	MACHOIRE DOUBLE+GRAISSEUR	HORQUILLA DOBLA+ENGRASADOR
3	F08010687	CROCERA COMPLETA	SPIDER ASSY	GELENKKREUZ KOMPL.	CROISIERE COMPL.	CRUCETA COMPLETA
4	F08010662	FORCELLA +TUBO EST+SPINA	FORK WITH EXTERNAL PIPE	GABELST. + AUSSENROHR	FOURCHE AVEC TUBE EXTERIEUR	HORQUILLA + TUBO EXTERNO
5	F08010661	FORCELLA +TUBO INT+SPINA	FORK WITH INTERNAL PIPE	GABELST. + AUSSENROHR	FOURCHE AVEC TUBE INT.	HORQUILLA + TUBO INT.
6	F08010897	PROTEZIONE COMPLETA	CARD PROTECTION ASSY	KOMPL. SCHUTZ	PROTECTION COMPL.	PROTECCION COMPL.

**USATE SEMPRE RICAMBI ORIGINALI
ALWAYS USE ORIGINAL SPARE PARTS
IMMER DIE ORIGINAL-ERSATZTEILE VERWENDEN
EMPLOYEZ TOUJOURS LES PIECES DE RECHANGE ORIGINALES
UTILIZAR SIEMPRE REPUESTOS ORIGINALES**



**Servizio Assistenza Tecnica - After Sales Service
Servizio Ricambi - Spare Parts Service
+39 049 9289888**

DEALER:



MASCHIO GASPARDO SpA
Registered Office and Production Plant
Via Marcello, 73 - 35011 Campodarsego (Padova) - Italy
Tel. +39 049 9289810
Fax +39 049 9289900
info@maschio.com
www.maschionet.com

MASCHIO DEUTSCHLAND GMBH
Äußere Nürnberger Straße 5
D - 91177 Thalmässing - Deutschland
Tel. +49 (0) 9173 79000
Fax +49 (0) 9173 790079
dialog@maschio.de
www.maschionet.de

MASCHIO FRANCE Sarl
1 rue Denis Papin ZA
F - 45240 La Ferte St. Aubin
France
Tel. +33 (0) 2.38.64.12.12
Fax +33 (0) 2.38.64.66.79
info@maschio.fr

000 MASCHIO-ГАСПАРДО РУССИЯ
Улица Пушкина, 117 Б
404126 Волжский
Волгоградская область
Тел. +7 8443 515152
факс. +7 8443 515153
info@maschio.ru

MASCHIO GASPARDO SpA
Production Plant
Via Mussons, 7 - 33075 Morsano al Tagliamento (PN) - Italy
Tel. +39 0434 695410
Fax +39 0434 695425
info@gaspardo.it

MASCHIO-GASPARDO USA Inc
120 North Scott Park Road
Eldridge, IA 52748 - USA
Ph. +1 563 2859937
Fax +1 563 2859938
info@maschio.us

MASCHIO-GASPARDO ROMANIA S.R.L.
Strada Înfrăţirii, F.N.
315100 Chisineu-Cris (Arad) -România
Tel. +40 257 307030
Fax +40 257 307040
info@maschio.ro

MASCHIO IBERICA S.L.
MASCHIO-GASPARDO POLAND
MASCHIO-GASPARDO UCRAINA
GASPARDO-MASCHIO TURCHIA
MASCHIO-GASPARDO CINA
MASCHIO-GASPARDO INDIA
MASCHIO-GASPARDO KOREA