

**MASCHIO GASPARDO S.p.A.**

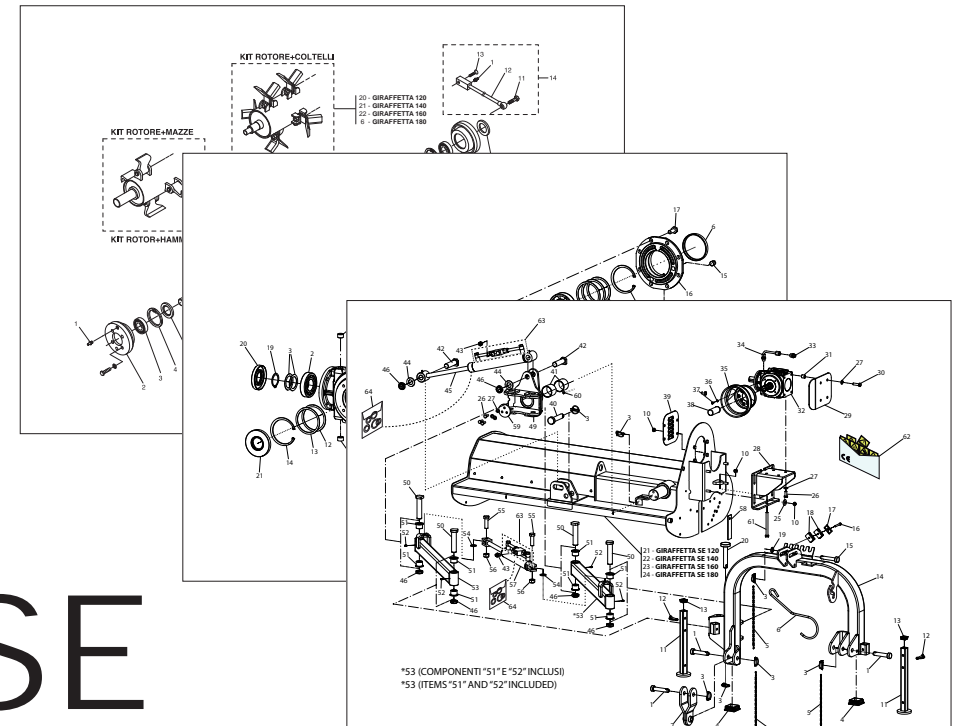

# GIRAFFETTA-SE

**Cod: F07011345 2015-12**

- \*) Valido per Paesi UE
- \*) Valid for EU member countries
- \*) Valable dans les Pays UE
- \*) Gilt für EU-Mitgliedsländer
- \*) Válido para Países UE

- IT** PARTI DI RICAMBIO
- EN** SPARE PARTS
- DE** ERSATZTEILE
- FR** PIÈCES DÉTACHÉES
- ES** PIEZAS DE REPUESTO

## ITALIANO

### PARTI DI RICAMBIO

Le ordinazioni delle parti di ricambio vanno fatte presso i nostri concessionari di zona e devono essere sempre corredate dalle seguenti indicazioni:

- **Tipo, modello e numero di matricola dell'attrezzatura.** Tali dati sono stampigliati nell'apposita targhetta di cui è dotata ogni attrezzatura.

- **Numero di codice della parte richiesta** rilevabile dal catalogo ricambi.

- **Descrizione del particolare e quantità richiesta.**

- **Numero della tavola.**

- **Mezzo di trasporto.** Nel caso questa voce non sia specificata, la Ditta Costruttrice, pur dedicando a questo servizio una particolare cura, non risponde di eventuali ritardi di spedizione dovuti a cause di forza maggiore.

Le spese di trasporto si intendono sempre a carico del destinatario. La merce viaggia a rischio e pericolo del committente anche se venduta franco destino.

**NOTA:** Il termine **(Dx) Destro** o **(Sx) Sinistro** della macchina o di parti di essa, è inteso guardando la macchina dalla parte posteriore. Le eccezioni saranno indicate.

## ENGLISH

### SPARE PARTS

*Orders must be transmitted through our area dealers and should always include the following indications:*

- **Type, model and serial number of the machine.** *These data are punched on the data plate with which every implement is equipped.*

- **Code number of the required spare part.** *This will be found in the spare parts catalogue.*

- **Description of the part and required quantity.**

- **Table number.**

- **Means of dispatch.** *If this item is not indicated, the Manufacturer, while dedicating particular care to this service, shall not be held responsible for delays in delivery caused by cases of force majeure.*

*Transport expenses shall always be at the consignee's charge. The goods travel at the purchaser's risk and peril even when sold ex destination.*

**NOTE:** *The symbols (Dx) right and (Sx) left, concerning the machine or single parts of it, are referred, as in the figure, to a rear view of them. Exceptions will be indicated.*

## DEUTSCH

### ERSATZTEILE

Die Bestellungen müssen bei unseren Gebietshändlern aufgegeben werden. Bei der Bestellung sind stets die folgenden Angaben zu machen:

- **Typ, Modell und Serien-Nummer des Geräts.** Diese Daten stehen auf dem Typenschild, mit dem jedes Gerät versehen ist.

- **Artikel Nr. der erforderlichen Ersatzteile.** Diese stehen im Ersatzteil-Katalog.

- **Beschreibung des Ersatzteils und die erforderliche Stückzahl.**

- **Tafelnummer.**

- **Versandmittel.** Wenn dieser Punkt nicht spezifiziert wird, haftet die Herstellerfirma nicht für etwaigen Lieferverzug aufgrund höherer Gewalt, auch wenn er diesen Service besonders aufmerksam abwickelt.

Die Frachtkosten gehen dagegen immer zu Lasten des Empfängers. Die Ware reist auf Gefahr und Risiko des Auftraggebers, auch wenn frei Haus verkauft vereinbart worden ist.

**N.B.:** Die Merkzeichen **(Dx) rechts** und **(Sx) links** betreffen eine rückwärtige Ansicht der Maschine oder Teile von ihr (siehe Bild). Ausnahmen werden gezeigt.

## FRANÇAIS

### PIECES DÉTACHÉES

*Les ordres doivent être effectués auprès de nos concessionnaires de zone en précisant les indications suivantes:*

- **Type, modèle et numéro de série de la machine.** *Ces données sont gravées sur la plaque d'identification de chaque outil.*

- **Numéro de code de la pièce détachée** *indiqué sur le catalogue des pièces détachées.*

- **Description de la pièce et quantité requise.**

- **Numéro de plan.**

- **Moyen d'expédition.** *Si cette rubrique n'est pas indiquée, le Constructeur, bien que soucieux de ce service, ne répond pas des retards d'expédition pour des causes de force majeure.*

*Les frais de transport sont toujours à la charge du destinataire. La marchandise voyage aux risques et périls de l'acheteur même si vendue franco de port.*

**N.B.:** *Les références (Dx) droit et (Sx) gauche de la machine ou des parties de la même, est entendue, comme de la figure, en regardant la machine de derrière dans le sens de marche.*

## ESPAÑOL

### RESPUESTOS

Los pedidos han de efectuarse en nuestros concesionarios de zona y deben incluir siempre las siguientes indicaciones:

- **Tipo, modelo y número de matrícula del equipo.** Dichos datos están impresos en la relativa placa presente en el equipo.

- **Número de código de la parte requerida** presente en el catálogo respuestas.

- **Descripción de la pieza y cantidad requerida.**

- **Numero de ilustración.**

- **Medio de transporte.** En caso que este ítem no esté especificado, el Fabricante, aún prestando la debidas consideraciones para este aspecto, no responde por eventuales retardos de env'o debidos a causas de fuerza mayor.

Los gastos de transporte se consideran siempre a cargo del destinatario. La mercadería viaja bajo riesgo y peligro del comprador, incluso cuando se vende franco destino.

**N.B.:** La referencia **(Dx) derecha** o **(Sx) izquierda** de la máquina o de sus componentes, se entiende, como en la figura, mirando la máquina por la parte trasera. Se indicarán las excepciones.

## INDICE

<i>N° Tavola</i>	<i>Descrizione</i>	<i>Pagina</i>
TAV. 010	Telaio e terzo punto.....	4
TAV. 020	Trasmissione .....	6
TAV. 030	Moltiplicatore 540 rpm.....	8
TAV. 040	Rotore .....	10
TAV. 050	Rullo e slitte .....	12
TAV. 060	Lamiera antiusura .....	14
TAV. 070	Impianto idraulico.....	16
TAV. 080	Supporti tabelle stradali .....	18
TAV. 090	Kit tabelle stradali G99600020.....	20
TAV. 100	Kit tabelle stradali G99600021 .....	22
TAV. 110	Cardano Bondioli .....	24

## INDEX

<i>N° Table</i>	<i>Description</i>	<i>Page</i>
TAV. 010	Frame and 3rd point hitch .....	4
TAV. 020	Transmission.....	6
TAV. 030	Gearbox 540 rpm .....	8
TAV. 040	Rotor .....	10
TAV. 050	Roller and skids .....	12
TAV. 060	Double skin frame .....	14
TAV. 070	Hydraulic plant .....	16
TAV. 080	Road kit supports .....	18
TAV. 090	Road transport kit G99600020.....	20
TAV. 100	Road transport kit G99600021 .....	22
TAV. 110	Bondioli cardan shaft .....	24

# TAV.010

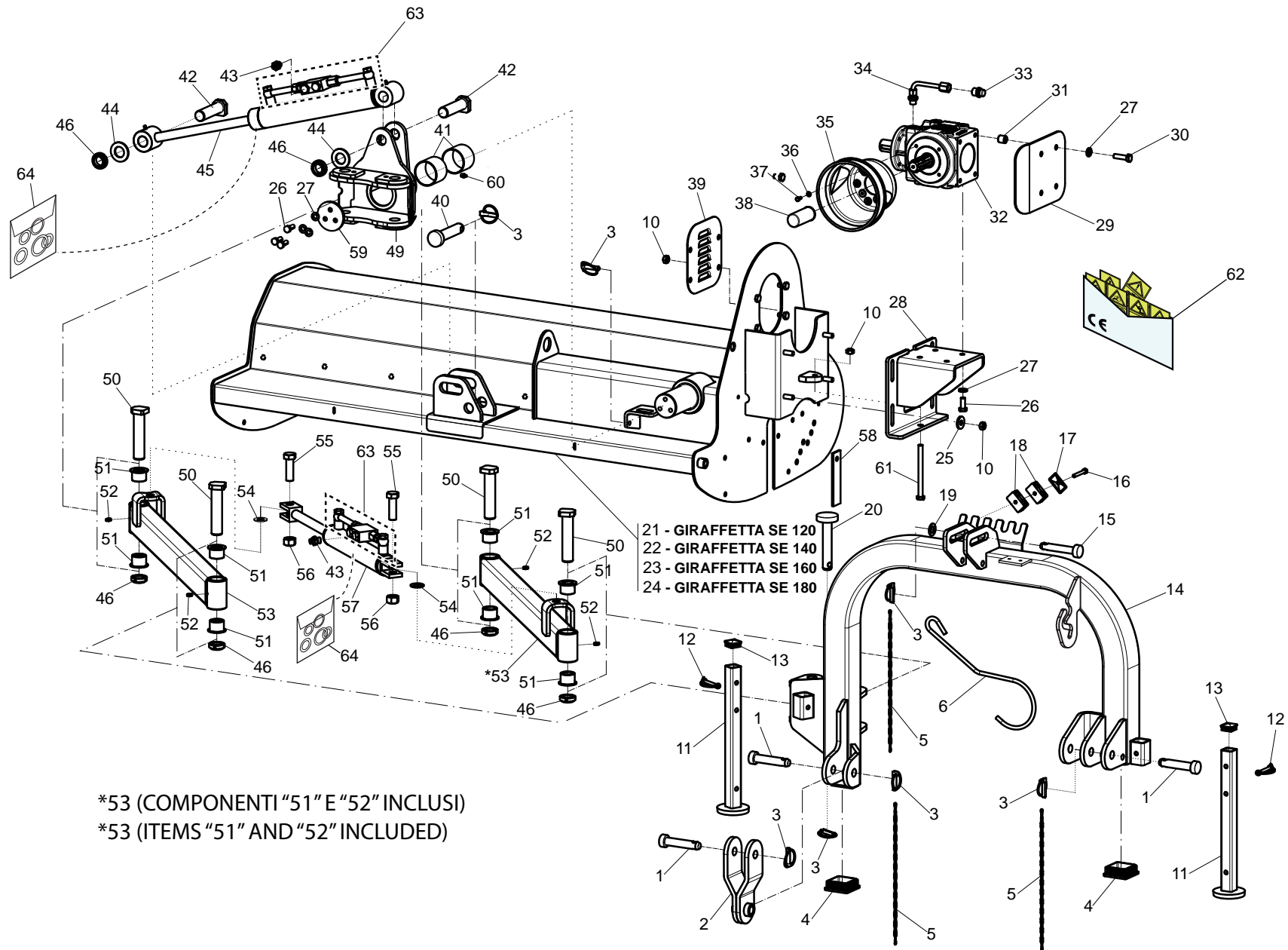

TELAIO E TERZO PUNTO / FRAME AND 3rd POINT HITCH

TAV.010

Pos.	Cod.	Descrizione	Description	Description	Benennung	Descrpcion
1	F20100049R	PERNO D22 L86 C43 TEST.D35 ZN	BOLT D22 L86 C43 ZN	GOUJON D.22	BOLZEN D.22	PERNO D.22
2	M41400546R	BIELLA	COMPL.PARALLEL LINK PISTONROD	BIELLE ATTELAGE	SCHUTZHOLM	BIELA ATAQUE
3	F02200529R	SPINA SCATTO D.11 H58 ZN	SNAP PIN D.11 H58 ZN	FICHE A DETENTE D.11 H58 ZN	EINRASTSTIFT D.11 H58 ZN	CLAVIJA DE MUELLE D.11 H58 ZN
4	F05100156R	TAPPO PER TUBO 70X70	PLASTIC CAP X PIPE 70X70 TK.5	BOUCHON 70X 70	ROHRKOPFSTOPFEN 70X 70	TAPON 70X 70
5	M58100930R	CATENELLA L=476	ASSEMBLY CHAIN DMP L=476	CHAINE L=476	KETTE L=476	CADENA L=476
6	F20120400R	GANCIO SOSTEGNO CARDANO	SHAFT HOOK SUPPORT	SUPPORT CARDAN	GELENKWELLE - HACKEN	SOPORTE CARDAN
10	F01220047R	DADO M12X1,25 D980 8ZN	NUT M12X1,25 D980 8ZN	ECROU M12X1,25 D980 8 ZN	MUTTER M12X1,25 D980 8 ZN	TUERCA M12X1,25 D980 8 ZN
11	M29100731R	COMP. PIEDINO SUPPORTO	SUPPORT	SUPPORT FRAISE	FRASE STANDER	SOPORTE FRESADORA
12	F02200562R	SPINA SICUR. D. 8X70 ZN	SNAP PIN D.8X 70 ZN	FICHE EL. D.8X70 ZN	SCHERSTIFT D.8X 70 ZN	CLAVIJA D.8X 70 ZN
13	F05100025R	TAPPO AD ALETTE 35X35 PLT NERO	PLUG	BOUCHON FERMETURE	VERSCHLUSSPFROPFEN	TAPONCLAUSURA
14	M41400573R	CASTELLO 3 PUNTO	THIRD POINT HITCH			
15	F20100035R	PERNO D19 L90 C43 TEST.D35 ZN	BOLT D19 L86 C43 ZN	BOULON D19 L86 C43	BÖLZEN D19 L86 C43	PERNO D19 L86 C43
16	F01020077R	VITE M8X1,25X60 U5737 8.8ZN	SCR. M8X1,25X60 U5737 8.8ZN	VIS M8X1,25X60 U5737 8.8 ZN	SCHRAU. M8X1,25X60 U5737 8.8ZN	TORN. M8X1,25X60 U5737 8.8 ZN
17	F03150993R	PIATTO X COLLARE SUPERIORE ZG	PLATE	PLAT	PLATTE	PLATO
18	F03151019R	COPPIA COLL.2T D12 1V I=00 M8	COLLAR PAIR 2T D12 1V I=00 M8			
19	F01410112R	ROS.M18 19X 34X 3 U6592 ZN	WASHER M18 19X 34X 3 U6592 ZN	RONDELLE M18 19X34X 3 U6592 ZN	SCHEIBE M18 19X 34X 3 U6592 ZN	ARANDELA M18 19X 34X3 U6592 ZN
20	F20100076R	PERNO D28 L154 C43 TEST.D45 ZN	PIN D28 L154 C40 ZN	BOULON D28 L154 C40 ZN	BOLZEN D28 L154 C40 ZN	PERNO D28 L154 C40 ZN
21	M74412515R	COMP.TELAIO SMALL GF. 120 SE	FRAME SMALL GF 120 EGB			
22	M74414515R	COMP.TELAIO SMALL GF. 140 SE	FRAME SMALL GF 140 EGB			
23	M74416515R	COMP.TELAIO SMALL GF. 160 SE	FRAME SMALL GF 160 EGB			
24	M74418515R	COMP.TELAIO SMALL GF. 180 SE	FRAME SMALL GF 180 EGB			
25	F01500011R	ROS. 13 X35X5 D6340 C50 ZN	WASHER D. 12	RONDELLE D.12	SCHEIBE D.12	ARANDELA D.12
26	F01010283R	VITE M12X1,25X30 U5740 8.8ZN	SCR. M12X1,25X30 U5740 8.8ZN	VIS M 12X1,25X30	SCHRAUBE M 12X1,25X30	TORNILLO M 12X1,25X30
27	F01480123R	ROS.G 12,5X22,9X 4 FLZNNC-240H	WASHER M12 ZGP EXTRA P.	RONDELLE M12 ZGP EXTRA P.	UNTERLEGSCHNEIBE M12 ZGP EXTRA	ARANDELA M12 ZGP EXTRA P.
28	M74400202R	SUPPORTO SCATOLA	BRACKET	SUPPORT	HALTERUNG	SOPORTE
29	M74400211R	PROTEZIONE LATERALE	SIDE PROTECTION	PROTECTION LAT.	SEITENSCHUTZ	PROTECCION LATERAL
30	F01010053R	VITE M12X1,25X45 U5738 8.8ZN	SCR. M12X1,25X45 U5738 8.8ZN	VIS M 12X1,25X45	SCHRAUBE M 12X1,25X45	TORNILLO M 12X1,25X45
31	T14002329R	DISTANZIALE D=20 D=12,5 L=20ZG	SPACER D=20 D=12,5 L=20	ENTRETOISE D=20 D=12,5 L=20	DISTANZSTUECK D=20 D=12,5 L=20	DISTANCIADOR D=20 D=12,5 L=20
32	M74400212R	SCATOLA MOLT. MASCHIO 540 RPM	BOX MULTIPL.MASCHIO 540 RPM			
33	F03150610R	TAPPO SFIATO 1 2 GAS CONICO	OIL BREATHER PLUG	BOUCHON D HUILE SOUPIRAIL	OELENTLUEFTERSTOPFEN	TAPON ACEITE
34	M07400216R	PROLUNGA SFIATO 90	BREATHER PLUG 90	BOUCHON DE SOUPIRAIL 90	ENTLUEFTERSTOPFEN 90	TAPON RESPIRADERO 90
35	F05150403R	CUFFIA PROTEZ.CARDANO X GRUPPO	POWER TAKE-OFF PROTECTION HOUS	PROTECTEUR PRISE DE PUISSANCE	SCHUTZKASTEN KRAFTABTRIEB	ENVOLTURA PROTECCI N T. DE P.
36	F01410037R	ROS.M6 6,4X12,5X1,6 U6592 ZN	WASHER M6 6,4X12,5X1,6 U6592ZN	RONDEL.M6 6,4X12,5X1,6 U6592ZN	SCHNEIB.M6 6,4X12,5X1,6 U6592ZN	ARAND.M6 6,4X12,5X1,6 U6592 ZN
37	F01020403R	VITE M6X1X16 U5739 8.8ZN	SCR. M6X1X16 U5739 8.8ZN	VIS M6X1X16 U5739 8.8 ZN	SCHRAUBE M6X1X16 U5739 8.8 ZN	TORNILLO M6X1X16 U5739 8.8 ZN
38	M38100146R	MANICOTTO PROTEZIONE PDF 1 3 8	P.T.O. PROTECTION	MANCHON DE PROTECTION P.T.O.	ZAPFWELLENSCHUTZ P.T.O.	MANGUITO PROTECCION P.T.O.
39	M07400939R	CARTER FIANCATA	CARTER	CARTER	GEHAEUSE	CARTER
40	F20100074R	PERNO D28 L109 C43 SPINA 3 P.	PIN FOR BAR LINKAGE	GOUJON ATTELAGE BARRE	VERB.BOLZEN SCHUTZHOLM	PERNO ATAQUE BARRA
41	F04100109R	BOCCOLA D=75 D=70 L=60 AUTOLUB	BUSHING D=75 D=70 L=60	BOUCLE D=75 D=70 L=60	BUECHSE D=75 D=70 L=60	ARANDELA D=75 D=70 L=60
42	M07400598R	COMP.PERNO D=30 L=109	PIN D=30 L=109	GOUJON D=30 L=109	STIFT D=30 L=109	PERNO D=30 L=109
43	F03150310R	NIPPLO MM CIL-CIL 3 8-1 4 ZN	NIPPLE CYL.MALE3 8-1 4 ZN	NIPPLE MALE CYL.3 8-1 4 ZN	NIPPELZYL.3 8-1 4 ZN	NIPLE MACHO CIL.3 8-1 4 ZN
44	F01410168R	ROS.M30 31X 56X 4 U6592 ZN	WASHER M30 31X56X4 U6592 ZN	RONDELLA M30 31X56X4 U6592 ZN	SCHRAUBE M30 31X56X4 U6592 ZN	ARANDELLA M30 31X56X4 U6592 ZN
45	M41400580R	MARTINETTO I.A.=100 C=361 L=744	HYDR.ADJ. ID.A=50 C=297 L=820	MANIVELLE HYDRAULIQUE	HYDRAUL.SPINDELVERSTELLUNG	GATO HYDRAULICO
46	F02010111R	GHIERA AU.GUP M30X1,5 T.4H ZN	SELF LOCKING NUT M30X1,5	COLLIER AUTOBL. M30X1,5	SELBSTSP. NUTMUTTER M30X1,5	VIROLA AUTOBL. M30X1,5
49	M41400568R	GIUNTO MOVIMENTAZIONE	JOINT			
50	M20700531R	PERNO D30 L168	PIN D30 L.168			
51	M07400929R	BOCCOLA D=30 D=40 L=30	BUSHING D=30 D=40 L=30	BOUCLE D=30 D=40 L=30	BUECHSE D=30 D=40 L=30	ARANDELA D=30 D=40 L=30
52	F01100011R	ING.M 6X1 7663-A 9SMNPB28 ZN	GREASE NIPPLE M6X1 7663-A ZN	GRAISS. A BILLE M6X1 7663A ZN	SCHMIERBUECHE M6X1 7663-A ZN	ENGRAS. DE ESFE. M6X1 7663-AZN
53	M41400583R	PARALLELOGRAMMA	LINKAGE ARM			
54	F01410124R	ROS.M20 21X 37X 3 U6592 ZN	WASHER M20 21X 37X 3 U6592 ZN	RONDEL.M20 21X37X3 ZN	MUTTER M20 21X 37X 3 U6592 ZN	ARANDELA M20 21X37X3 U6592 ZN
55	F01010169R	VITE M20X1,5X65 U5738 8.8ZN	SCR. M20X1,5X65 U5738 8.8ZN	VIS M 20X1,5X65	SCHRAUBE M 20X1,5X65	TORNILLO M 20X1,5X65
56	F01220093R	DADO M20X1,5 D980 8ZN	NUT M20X1,5 D980 8ZN	ECROU AUTOBL.M20X1,5 ZN	SELB.MUTTER M20X1,5 D980 8ZN	TUERCA AUTOBL.M20X1,5 D980 8ZN
57	M41400581R	MARTINETTO I.A.=50 C=225 L=695	HYDR.ADJUSTER A=50 C=225 L=695	MANIVELLE HYDRAULIQUE	HYDRAUL.SPINDELVERSTELLUNG	GATO HYDRAULICO
58	M33400514R	CHIUSURA LATERALE	REAR LATERAL PANEL	CAPOT ARRIERE LATERAL	HINTERE BLECH	PLANCHA LATERALE
59	M41400590R	ROSETTA DI BLOCCAGGIO	PLANE WASHER			
60	F01100061R	ING.M10X1 7663-A 9SMNPB28 ZN	GREASE NIPPLE M10X1 7663-A ZN	GRAISSEUR M10X1 7663-A ZN	SCHMIERBUECHSE M10X1 7663-A ZN	ENGRASADOR M10X1 7663-A ZN
61	F01010302R	VITE M12X1,25X150 U5740 8.8ZN	SCREW M12X1,25X150 U5740 8.8ZN	VIS M12X1,25X150 U5740 8.8ZN	SCHRAUBE M12X1,25X150 U5740 8.8ZN	TORNILLO M12X1,25X150 U5740 8.8ZN
62	F20030241R	KIT.ET.CE TRINCIA	KIT CE LABELS MULCHERS			
63	F03151158R	KIT VALVOLA BLOCCO 3 8 7014200	KIT VALVE BLOCK.3 8 7014200	SOUPAPE D ARRET AUTOMATIQUE	AUTOM. VENTIL 3 8	VALVULA DE CRIERRE 3 8 7014200
64	F03100327R	KIT.GUARNIZIONI M41400580-581	KIT.GU.M41400580-582			

# TAV.020

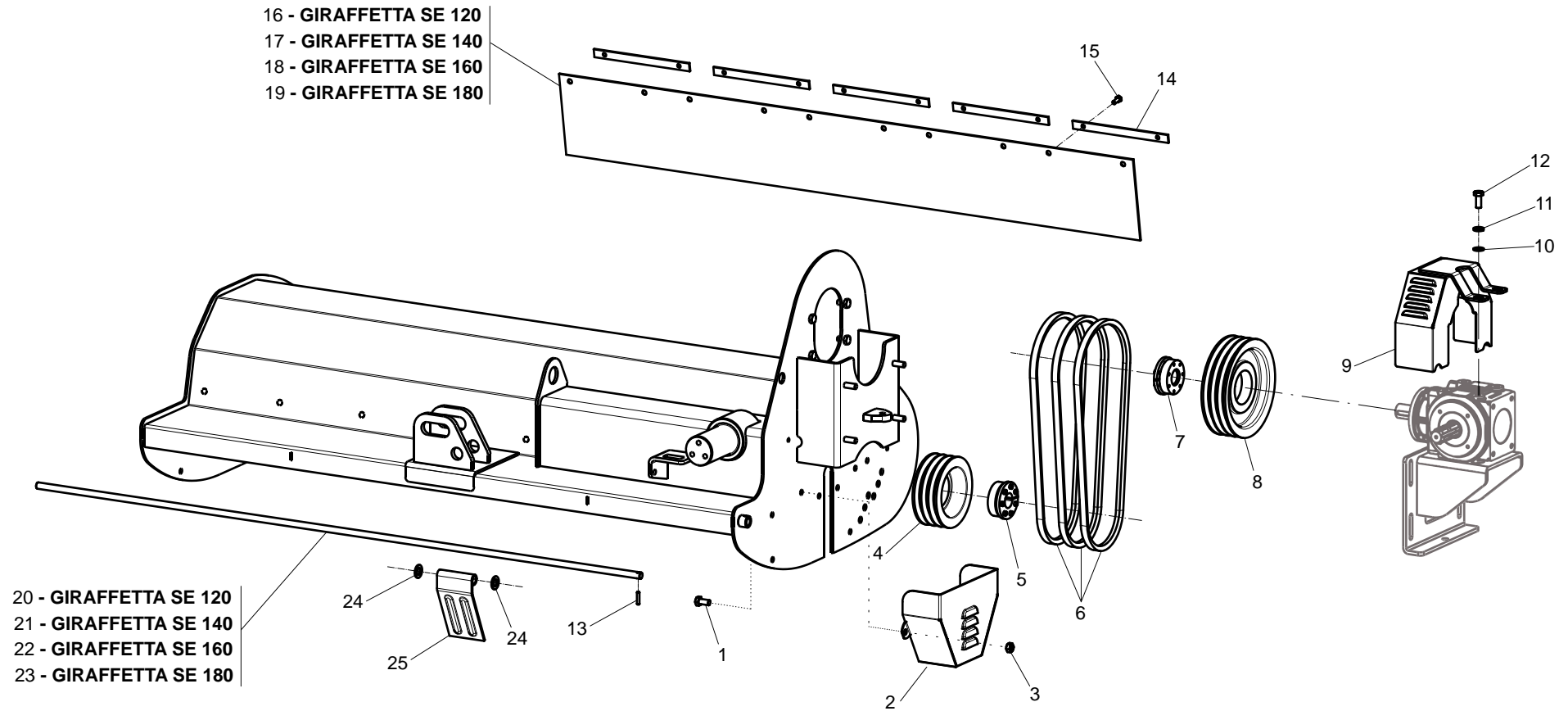

TRASMISSIONE / TRANSMISSION

TAV.020

Pos.	Cod.	Descrizione	Description	Description	Benennung	Description
1	F01010281R	VITE M12X1,25X25 U5740 8.8ZN	SCR. M12X1,25X25 U5740 8.8ZN	VIS M 12X1,25X25	SCHRAUBE M 12X1,25X25	TORNILLO M 12X1,25X25
2	M74400208R	CARTER BASSO	CARTER	CARTER	GEHAEUSE	CARTER
3	F01220047R	DADO M12X1,25 D980 8ZN	NUT M12X1,25 D980 8ZN	ECROU M12X1,25 D980 8 ZN	MUTTER M12X1,25 D980 8 ZN	TUERCA M12X1,25 D980 8 ZN
4	T22003001R	PULEGGIA ROTORE DP=160	DRIVING PULLEY	POULIE TIRANTE	ZIEHEN RIEMEN	ROLDANA DE TIRAR
5	F06060037R	CALETTATORE AUTOCENTR.35X80	SELF CENTR.CLAMPEL.35X80	EMBOITAGE AUOBL. 35X80	SELBSTPERR.VERKEILEN 35X80	ENSAMBLADURA AUTOBL. 35X80
6	F06010039R	CINGHIA SPBX L=1320	BELT SPBX L=1320	COURROIE L=1320	SCHAUBE SPBX L=1320	CORREA SPBX L=1320
7	F06060036R	CALETTATORE AUTOC. 33X80	SELF CENTR.CLAMPEL.33X80	EMBOITAGE AUOBL. 33X80	SELBSTPERR.VERKEILEN 33X80	ENSAMBLADURA AUTOBL. 33X80
8	T16003002R	PULEGGIA SPB MOTRICE D=225 3V	DRIVING PULLEY	POULIE TIRANTE	ZIEHEN RIEMEN	ROLDANA DE TIRAR
9	M74400205R	CARTER ALTO	CARTER	CARTER	GEHAEUSE	CARTER
10	F01410076R	ROS.M12 13X 24X2,5 U6592 ZN	WASHER 12 13X 24X2,5 U6592 ZN	RONDEL. M12 13X24X2,5 U6592 ZN	SCHIEBE M12 13X24X2,5 U6592 ZN	ARANDELA M12 13 X24X2,5 ZN
11	F01480123R	ROS.G 12,5X22,9X 4 FLZNNC-240H	WASHER M12 ZGP EXTRA P.	RONDELLE M12 ZGP EXTRA P.	UNTERLEGSCHIEBE M12 ZGP EXTRA	ARANDELA M12 ZGP EXTRA P.
12	F01010283R	VITE M12X1,25X30 U5740 8.8ZN	SCR. M12X1,25X30 U5740 8.8ZN	VIS M 12X1,25X30	SCHRAUBE M 12X1,25X30	TORNILLO M 12X1,25X30
13	F02100114R	SPINA E.P. 6X 30 U6873 C70 BR	ELASTIC PIN 6X30	GOUJON ELASTIQUE 6X30	SPANNHUELSE 6X30	ESPINA ELASTICA 6X30
14	M07400953R	PIATTO PER ATTACCO GOMMA	PLATE	PLAT	PLATTE	PLATO
15	F02250160R	RIVETTO STR. 6,4X22 ACCIAIO	RIVET	RIVET	KUPFERNIET	REMACHE
16	M33412544R	PROTEZ.POSTER.120	REAR PROTECTION 120	PROTECTION ARRIERE 120	HINTERER SCHUTZ 120	PROTECCION TRASERA 120
17	M33414544R	PROTEZ.POSTER.140	REAR PROTECTION 140	PROTECTION ARRIERE 140	HINTERER SCHUTZ 140	PROTECCION TRASERA 140
18	M33416544R	PROTEZ.POSTER.160	REAR PROTECTION 160	PROTECTION ARRIERE 160	HINTERER SCHUTZ 160	PROTECCION TRASERA 160
19	M33418544R	PROTEZ.POSTER.180	REAR PROTECTION 180	PROTECTION ARRIERE 180	HINTERER SCHUTZ 180	PROTECCION TRASERA 180
20	T21115016R	ASTA PER BANDELLE	PIN	GOUJON	BOLZEN	PERNO
21	T21135016R	ASTA PER BANDELLE	PIN	GOUJON	BOLZEN	PERNO
22	T21155016R	ASTA PER BANDELLE	PIN	GOUJON	BOLZEN	PERNO
23	T21185016R	ASTA PER BANDELLE BCA180-BL170	PIN	GOUJON	BOLZEN	PERNO
24	F01410100R	ROS.M16 17X 30X 3 U6592 ZN	WASHER M16 17X30X3 U6592 ZN	RONDELLE M16 17X30X3 ZN	SCHRAUBE M16 17X 30X3 U6592 ZN	ARANDELA M16 17X30X 3 U6592 ZN
25	M24400518R	BANDELLA PROTEZ. 93X170 ZG	PROTECTION BAR	BANDE PROTECTION	SCHUTZWORNE	ALETA PROTECCION

**TAV.030**

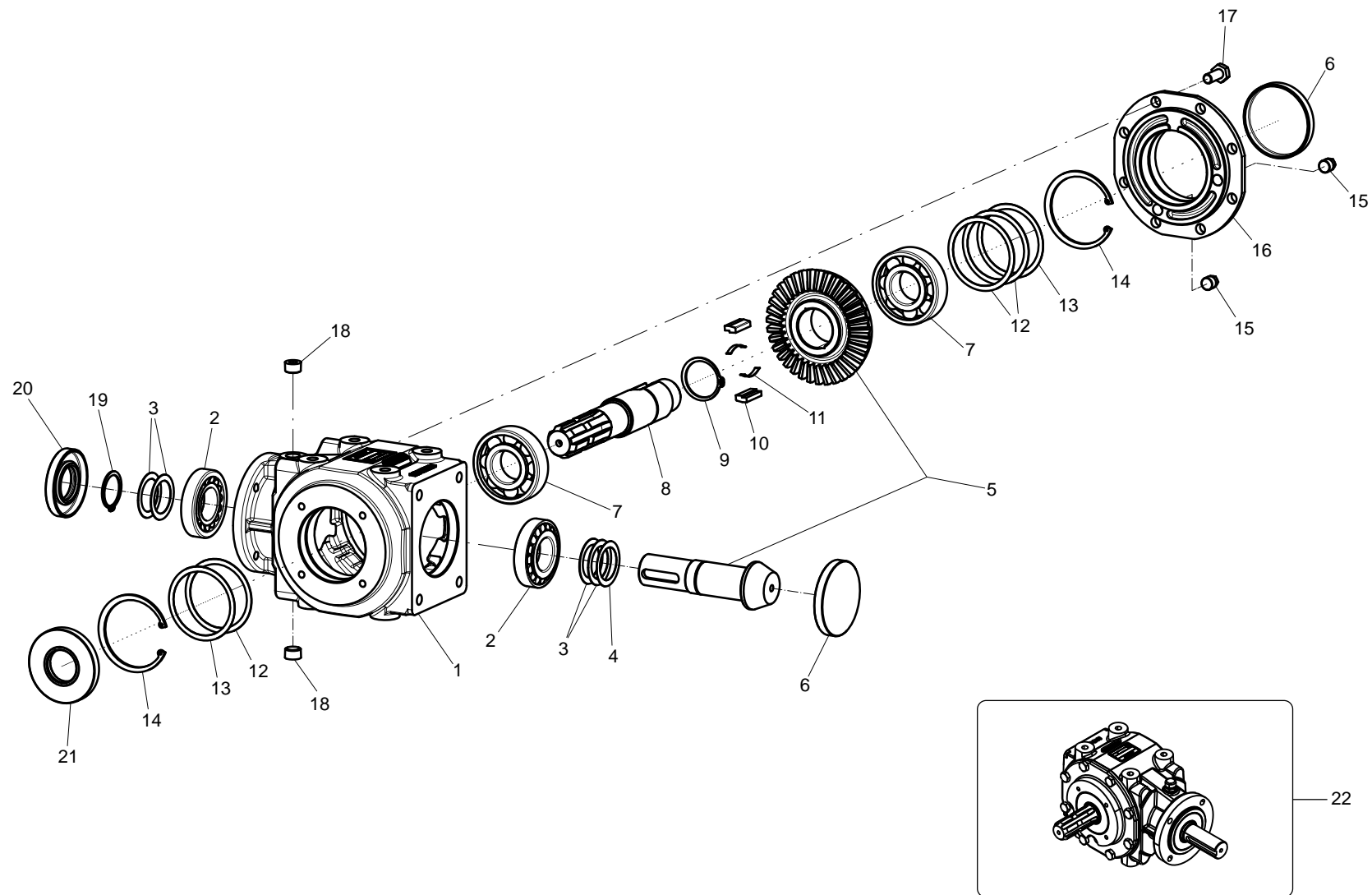



MOLTIPLICATORE 540 rpm / GEARBOX 540 rpm

TAV.030

Pos.	Cod.	Descrizione	Description	Description	Benennung	Description
1	M22400101R	CORPO RIDUTTORE	GEARBOX	BOITE DE VITESSE	WECHSELGETRIEBEGEHAUSE	CAJA CAMBIO
2	F04050014R	CUSC.D35 D72 T18,25 30207	BEARING D35 D72 T18,25 30207	ROULEMENT 30207	LAGER 30207	COJINETE 30207
3	T24001216R	ROSETTA D=48 D=35,5 L=0,5	WASHER D=48 D=35,5 L=0,5	ROSETTE D=48 D=35,5 L=0,5	SCHEIBE D=48 D=35,5 L=0,5	ARANDELLA D=48 D=35,5 L=0,5
4	T24001215R	ROSETTA D=48 D=35,5 L=0,25	WASHER D=48 D=35,5 L=0,25	ROSETTE D=48 D=35,5 L=0,25	SCHEIBE D=48 D=35,5 L=0,25	ARANDELLA D=48 D=35,5 L=0,25
5	M74400107R	COPPIA CONICA 12 36	BEVEL GEAR PAIR 12 36			
6	F03011026R	TAPPO CHIUSURA D=80 X 10 GA	COVER D. 80X10	BOUCHON 80X10	DECKEL 80X10	CORCHO 80X10
7	F04010216R	CUSC.D35 D80 B21 6307	BEARING D35 D80 B21 6307	ROULEMENT 6307	LAGER 6307	COJINETE 6207
8	M74400106R	ALBERO CORONA D=42 L=227	SHAFT D=42 L=227	ARBRE COURONNE D=42 L=227	KEGELRADWELLE D=42 L=227	ARBOL CORONA D=42 L=227
9	F02050179R	ANELLO E. DE 42X1,75 U7435	COMPRESSION RING D.42	ANNEAU RESSORT D.42	RING D.42	ANILLO D.42
10	T24001204R	LINGUETTA DI INNESTO	KEY	CLAVETTE	KEIL	LLAVE
11	T24001203R	MOLLA	SPRING	RESSORT	FEDER	MUELLE
12	T40001003R	SPESSORI REG. D79.5 D67.5 S0.5	THICKNESS D79.5 D67.5 S0.5	EPAISSEUR D79.5 D67.5 S0.5	PLAETTCHEN D79.5 D67.5 S0.5	ESPESOR D79.5 D67.5 S0.5
13	T24001213R	ROSETTA D=79,6 D=69,4 L=0,15	WASHER D=79,6 D=69,4 L=0,15	ROSETTE D=79,6 D=69,4 L=0,15	SCHEIBE D=79,6 D=69,4 L=0,15	RANDELLA D=79,6 D=69,4 L=0,15
14	F02050425R	ANELLO E. DI 80X 2,5 U7437 C70	SEEGER RING D.80	BAGUE SEEGER D.80	SEEGERRING D.80	ANILLO SEEGER D.80
15	F03150652R	TAPPO CONICO CON ES.INC. 1 4	HEXAGONAL PLUG 1 4	BOUCHON CONIQUE 1 4	KONISCHER VERSCHLUSS 1 4	CIERRE CONICO 1 4
16	M22400102R	COPERCHIO	GEARBOX COVER	COUVERCLE BOITE A VITESSES	GETRIEBEDECKEL	TAPA CAJA CAMBIO
17	F01010244R	VITE M10X1,25X25 U5740 8.8ZN	SCR. M10X1,25X25 U5740 8.8ZN	VIS M 10X1,25X25	SCHRAUBE M 10X1,25X25	TORNILLO M 10X1,25X25
18	F03150719R	TAPPO 3 8 GAS	GAS CAP 3 8	BOUCHON	DECKEL	CORCHO
19	F02050146R	ANELLO E. DE 35X 1,5 U7435 C70	ELASTIC RING DE 35X 1,5 U7435	BAGUE ELASTIQUE DE 35X 1,5	RING DE 35X 1,5 U7435 C70	ANILLO DE 35X 1,5 U7435 C70
20	F03010088R	ANELLO T.AS.35X 72X10 D3760NBR	OIL SEAL 35X72X10	PARA-HUILLE 35X72X10	OELABDICHTUNG 35X72X10	PARA-ACEITE 35X72X10
21	F03010265R	ANELLO T.AS 35X 80X10 D3760NBR	RING T.AS 35X80X10 D3760 NBR	BAGUE T.AS 35X 80X10 D3760 NBR	SCHUTZRING 35X80X10 D3760 NBR	INEL T.AS 35X80X10 D3760 NBR
22	M74400212R	SCATOLA MOLT. MASCHIO 540 RPM	BOX MOLTIPL.MASCHIO 540 RPM			

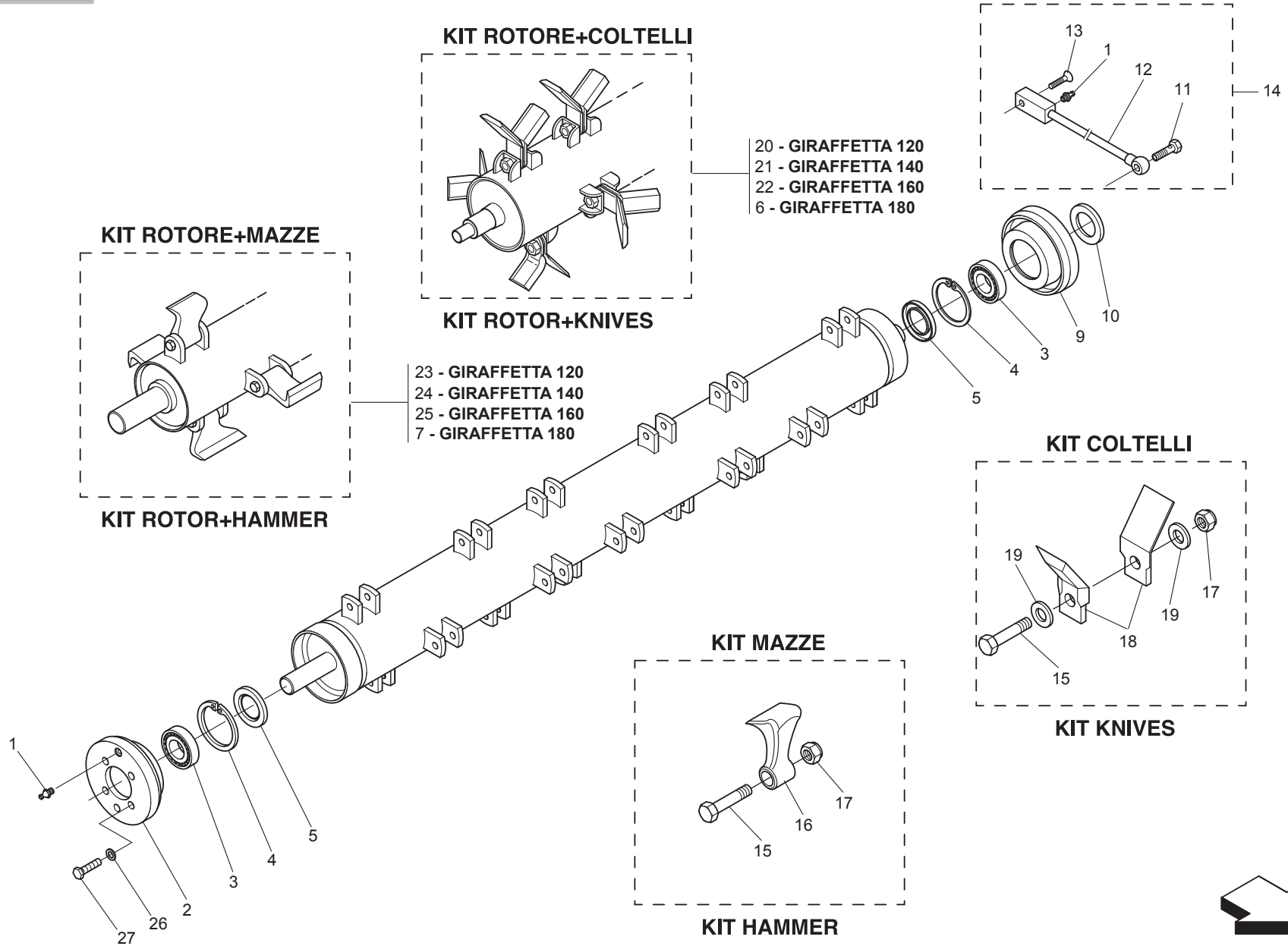

ROTORE / ROTOR

TAV.040

Pos.	Cod.	Descrizione	Description	Description	Benennung	Description
1	F01100011R	ING.M 6X1 7663A 9SMNPB28 Z	GREASE NIPPLE M6X1 7663-A ZN	GRAISS. A BILLE M6X1 7663A ZN	SCHMIERBUECHE M6X1 7663-A ZN	ENG.M 6X1 7663-A 9SMNPB28 ZN
2	M22400406R	SUPPORTO ROTORE DX	RIGHT ROTOR SUPPORT	SUPPORT ROTOR DROITE	ROTORHALTER RECHTE	SOPORTE ROTOR DERECHO
3	F04010277R	CUSC.D35 D72 B23 22207	BEARING D35 D72 B23 22207	ROULEMENT D35 D72 B23	LAGER D35 D72 B23	COJINETE D35 D72 B23
4	F02050403R	ANELLO E. DI 72X 2,5 U7437 C7	SEEGER RING E.72X2,5 U7437 C70	SEEGER E. 72X 2,5 U7437 C70	SEEGERING E. 72X 2,5 U7437 C70	ANILLO E. DI 72X 2,5 U7437 C7
5	F03010136R	ANELLO T.AS.45X 72X 8 D3760NBR	OIL SEAL 45X72X8 D3760NBR	PARE-HUILE 45X72X8	OELABDICHTUNG 45X72X8	JUNTA DE ACEITE 45X72X8
6	M334184021R	ROTORE BARBI 180 C18 NO SUPP.	ROTOR BARBI 180 BLADE 18		ROTOR BARBI 180 C18 NO HALTER	
7	M334184011R	ROTORE BARBI180 M20 NO SUPP.	ROTOR BARBI 180 HAMMER 20		ROTOR BARBI 180 M20 NO HALTER	
9	M22400405R	SUPPORTO ROTORE SX	LEFT ROTOR SUPPORT	SUPPORT ROTOR GAUCHE	ROTORHALTER LINKS	SOPORTE ROTOR IZQUIERDO
10	F03010086R	ANELLO T.A 35X 62X 7 D3760NBR	OIL SEAL 35X62X7	PARE-HUILE 35X62X7	OELABDICHTUNG 35X62X7	PARA-ACEITE 35X62X7
11	T24004003R	VITE FORATA PER INGRASSAGGIO	BOLT	VIS	SCHRAUBE	TORNILLO
12	T24004000R	ASSIEME INGRASSATORE	GREASE NIPPLE	GRAISSEUR	SCHMIERNIPPEL	ENGRASADOR
13	F01030058R	VITE M8X1,25X30	SCREW M8X1,25X30	VIS M8X1,25X30	SCHRAUBE M8X1,25X30	TORNILLO M8X1,25X30
14	T24004000R	ASSIEME INGRASSATORE	GREASE NIPPLE	GRAISSEUR	SCHMIERNIPPEL	ENGRASADOR
15	F20110091R	VITE M16X1,5X85	SCREW M16X1,5X85	VIS M16X1,5X85	SCHRAUBE M16X1,5X85	TORNILLO M16X1,5X85
16	M07400950R	MAZZA 20 STAMPATA	HAMMER 20	MARTEAU 20 BARBI-GIRAFETTA	SCHLEGEL	MARTILLO 20
17	F01230084R	DADO M16X1,5	NUT M16X1,5	ECROU M16X1,5	MUTTER M16X1,5	DADO AUTOBL. M16X1,5
18	M07400954R	COLTELLO 18	KNIFE*18	COUTEAU 18 GALVANISE P		
19	T21004046R	DISTANZIALE COLTELLO ZPG	SPACER KNIFE	DIUTEAU TIPE ZN	SCHEIBE 04-06	
20	M334124021R	ROTORE 120 COLT. 18	ROTOR 120 BLADE 18	ROTOR 120 COUTEAUX 18	LAEUFER 120 MESSER 18	ROTOR 120 CUCHILLO 18
21	M334144021R	ROTORE 140 COLT. 18	ROTOR 140 BLADE 18	ROTOR 140 COUTEAUX 18	LAEUFER 140 MESSER 18	ROTOR 140 CUCHILLO 18
22	M334164021R	ROTORE 160 COLT. 18	ROTOR 160 BLADE 18	ROTOR 160 COUTEAUX 18	LAEUFER 160 MESSER 18	ROTOR 160 CUCHILLO 18
23	M334124011R	ROTORE 120 M20 NO SUPP.	ROTOR 120 HAMMER 20	ROTOR 120 MARTEAUX 20	LAEUFER 120 SCHLEGEL 20	ROTOR 120 MARTILLO 20
24	M334144011R	ROTORE BARBI 140 M20 NO SUPP.	ROTOR 140 HAMMER 20	ROTOR 140 MARTEAUX 20	LAEUFER 140 SCHLEGEL 20	ROTOR 140 MARTILLO 20
25	M334164011R	ROTORE BARBI 160 M20 NO SUPP.	ROTOR 160 HAMMER 20	ROTOR 160 MARTEAUX 20	LAEUFER 160 SCHLEGEL 20	ROTOR 160 MARTILLO 20
26	F01480123R	ROS.G 12,5X22,9X 4	GROVER WASHER M12 ZGP EXTRA P.	GROVER RONDELLE M12 ZGP EXTRA	UNTERLEGSCHLEIBE M12 ZGP EXTRA	ARANDELA M12 ZGP EXTRA P.
27	F01010283R	VITE M12X1,25X30	SCREW M12X1,25X30	VIS M12X1,25X30	SCHRAUBE M12X1,25X30	TORNILLO M12X1,25X30

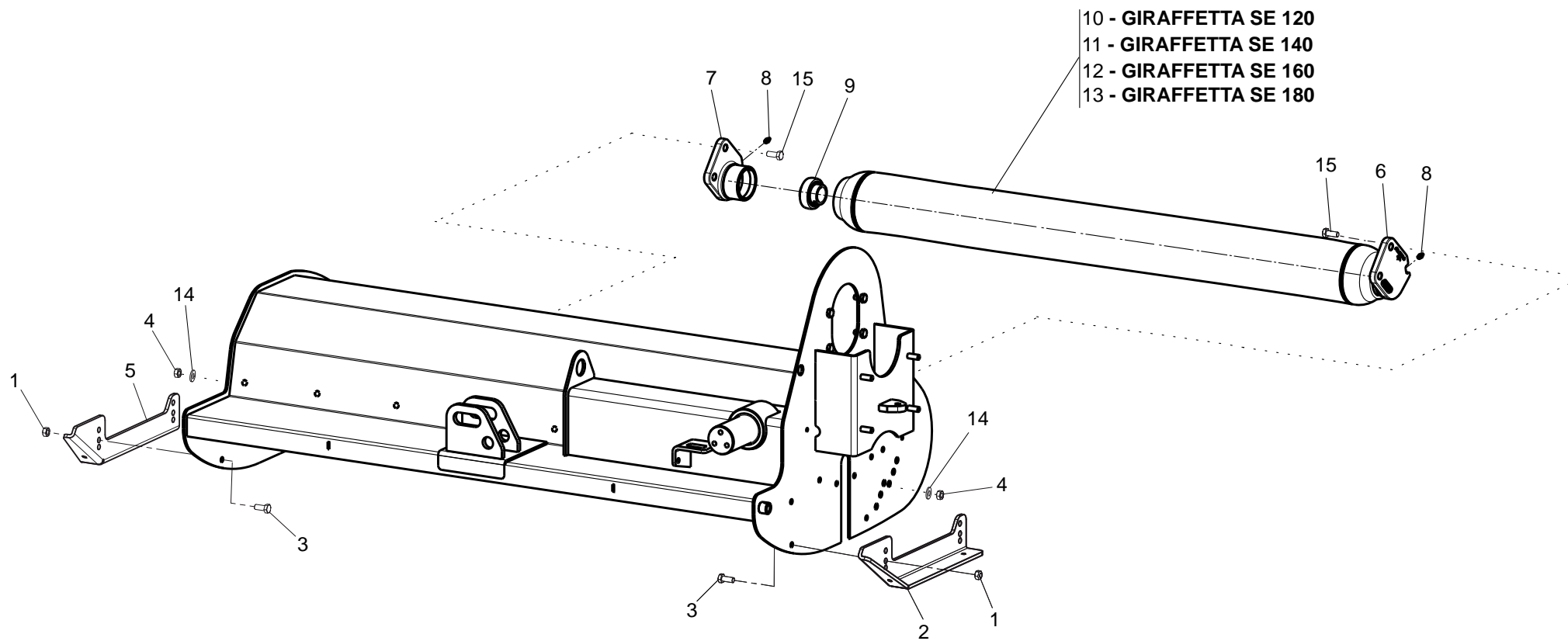

**RULLO E SLITTE / ROLLER AND SKIDS**

**TAV.050**

Pos.	Cod.	Descrizione	Description	Description	Benennung	Description
1	F01220047R	DADO M12X1,25 D980 8ZN	NUT M12X1,25 D980 8ZN	ECROU M12X1,25 D980 8 ZN	MUTTER M12X1,25 D980 8 ZN	TUERCA M12X1,25 D980 8 ZN
2	T23005214R	SLITTA SX BC-BE-CL	LEFT SKID	GLISSIERE COTE GAUCHE	LINKS GLEITKUFE	TRINEO LADO IZQUIERDO
3	F01010283R	VITE M12X1,25X30 U5740 8.8ZN	SCR. M12X1,25X30 U5740 8.8ZN	VIS M 12X1,25X30	SCHRAUBE M 12X1,25X30	TORNILLO M 12X1,25X30
4	F01220059R	DADO M14X1,5 D980 8ZN	NUT M14X1,5 D980 8ZN	ECROU M14X 1,5 D980 8 ZN	MUTTER M14X 1,5 D980 8 ZN	TUERCA M14X 1,5 D980 8 ZN
5	T23005213R	SLITTA DX BC-BE-CL	RIGHT SKID	GLISSIERE COTE DROIT	RECHTS GLEITKUFE	TRINEO LADO DERECHO
6	EGL01234R	KIT SUPPORTO SX CUSCINETTO	KIT SUPPORT LEFT BEARING			
7	EGL01235R	KIT SUPPORTO DX CUSCINETTO	KIT SUPPORT RIGHT BEARING			
8	F01100035R	ING.M 8X1 7663-A 9SMNPB28 ZN	GREASE NIPPLE M8X1	GRAISSEUR M8X1	SCHMIERBUECHSE M8X1	ENGRASADOR M8X1
9	F04010361R	CUSC. YAR 207-2FW VA201	BEARING YAR 207			
10	M33412611R	RULLO POSTERIORE D=139,7	REAR ROLLER D=139,7			
11	M33414611R	RULLO POSTERIORE D=139,7	REAR ROLLER D=139,7			
12	M33416611R	RULLO POSTERIORE D=139,7	REAR ROLLER D=139,7			
13	M33418611R	RULLO POSTERIORE D=139,7	REAR ROLLER D=139,7			
14	F01410088R	ROS.M14 15X 28X2,5 U6592 ZN	WAS.M14 15X 28X2,5 U6592 ZB	RON.M14 15X 28X2,5 U6592 ZB	SCH.M14 15X 28X2,5 U6592 ZB	ARA.M14 15X 28X2,5 U6592 ZB
15	F01010318R	VITE M14X1,5X40 U5740 8.8ZN	SCR. M14X1,5X40 U5740 8.8ZN	VIS M 14X1,5X40	SCHRAUBE M 14X1,5X40	TORNILLO M 14X1,5X40

**TAV.060**

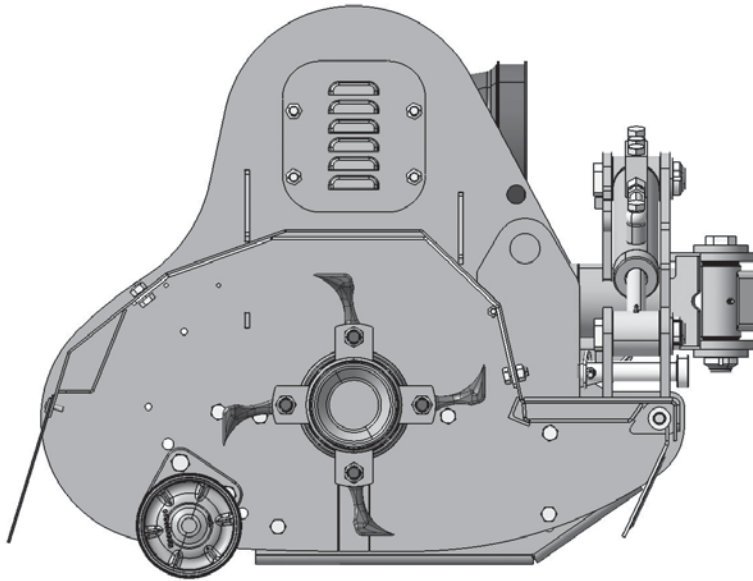

- 1 - GIRAFFETTA 120
- 2 - GIRAFFETTA 140
- 3 - GIRAFFETTA 160
- 4 - GIRAFFETTA 180

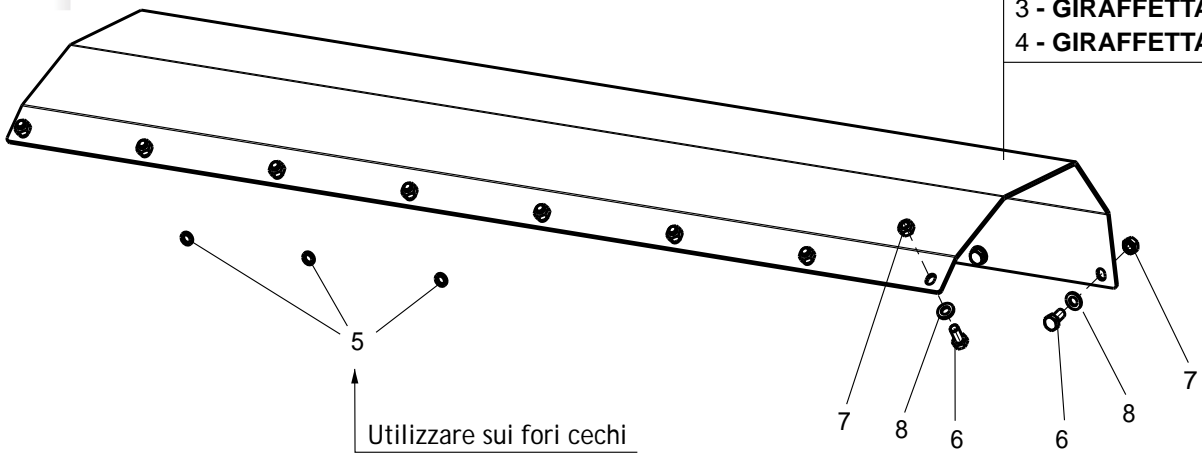

Utilizzare sui fori ciechi  
To be used on blind holes

**LAMIERA ANTIUSURA / DOUBLE SKIN FRAME**

**TAV.060**

Pos.	Cod.	Descrizione	Description	Description	Benennung	Descripcion
1	M33412598R	LAMIERA ANTIUSURA	DOUBLE SKIN FRAME			
2	M33414598R	LAMIERA ANTIUSURA	DOUBLE SKIN FRAME			
3	M33416598R	LAMIERA ANTIUSURA	DOUBLE SKIN FRAME			
4	M33418598R	LAMIERA ANTIUSURA	DOUBLE SKIN FRAME			
5	F01480055R	ROS.G 12,2X 18X2,5 D7980 ZN	WASHER. 12.2X18X2,5 D7980ZN	ROND.ELAST. 12,2X18X2,5D7980ZN	FEDERRINGE 12,2X18 2,5 D7980ZN	ARAND. EL. 12,2X18X2,5 D7980ZN
6	F01010281R	VITE M12X1,25X25 U5740 8.8ZN	SCR. M12X1,25X25 U5740 8.8ZN	VIS M 12X1,25X25	SCHRAUBE M 12X1,25X25	TORNILLO M 12X1,25X25
7	F03020070R	RONDELLA BONDED AUTOCENT 3 8	AUTOCENT BONDED WASHER 3 8	RONDELLE BONDED AUTOCENT 3 8	SCHEIBE BONDED AUTOCENT 3 8	ARANDELA BONDED AUTOCENT 3 8
8	F01410076R	ROS.M12 13X 24X2,5 U6592 ZN	WASHER 12 13X 24X2,5 U6592 ZN	RONDEL. M12 13X24X2,5 U6592 ZN	SCHEIBE M12 13X24X2,5 U6592 ZN	ARANDELA M12 13 X24X2,5 ZN

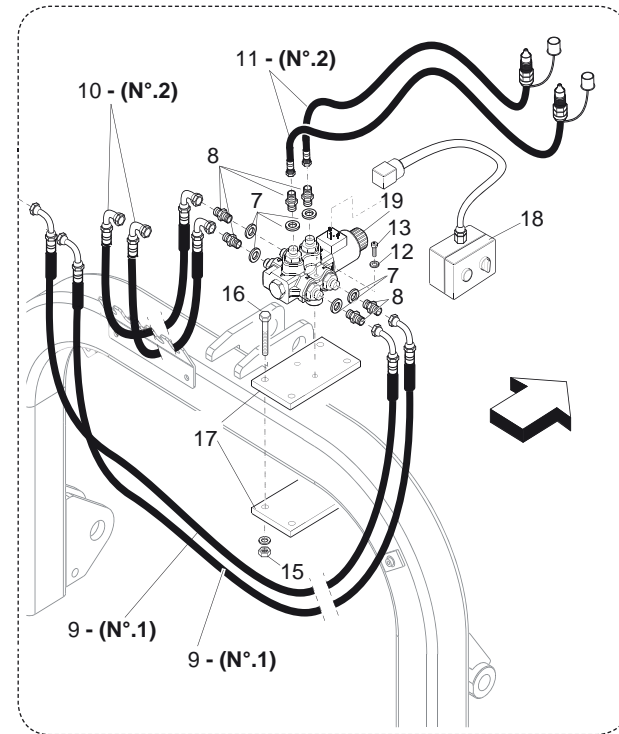
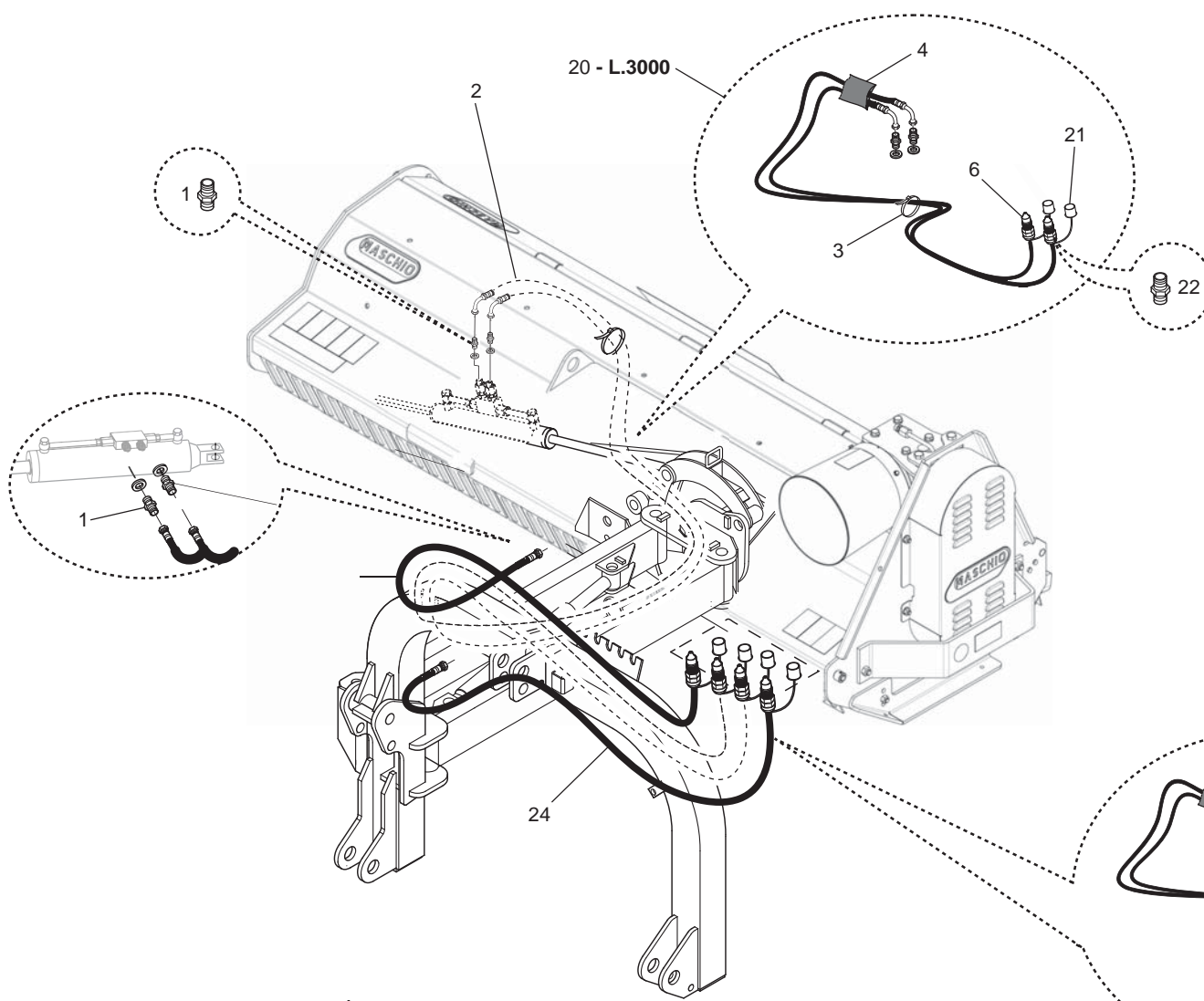

**KIT RIDUZIONE TUBI IDRAULICI OPTIONAL**  
**OPTIONAL HYDRAULIC TUBE REDUCTION KIT**

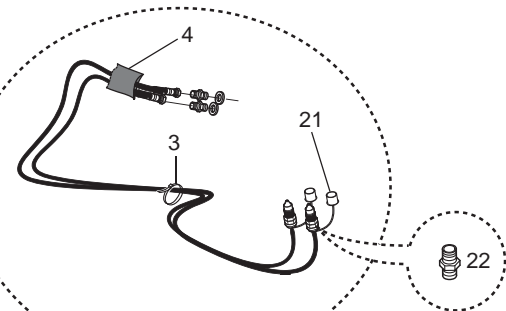

**23 - L.1900**



**IMPIANTO IDRAULICO - HYDRAULIC PLANT**

**TAV.070**

Pos.	Cod.	Descrizione	Description	Description	Benennung	Description
1	F03080081R	NIPPLO M3 8 SEAL ML10 ZN	NIPPLE M3 8 SEAL ML10 ZN			
2	F03060190R	COMP.TUBAZ.IDR. L3000 DIN24	HYDRAULIC PIPE L3000 DIN24			
3	F05150055R	FASCETTA POLYA. 3,6X200 NERA	WHITE BAND	BANDE BIANCHE	WEIBE BAND	CINTA BLANCA
4	F03100362R	GUAINA TELATA D=65 L=2350	SHEATH D=65 L=2350	GAINÉ D=65 L=2350	KABEL D=65 L=2350	VAINA D=65 L=2350
6	F03080090R	INNESTO RAP.MASCH.DL M16X1,5	QUICK CONNECT MALE CONE DL M16			
7	F03100023R	ROS. 17 X23X1,5 RAME -3 8	WASHER 17X23X1,5 RAME -3 8	RONDELLE 17X23X1,5 RAME -3 8	SCHEIBE 17X23X1,5 RAME -3 8	ARAN. 17 X23X1,5 RAME -3 8
8	F03150310R	NIPPLO MM CIL-CIL 3 8-1 4 ZN	NIPPLE CYL.MALE3 8-1 4 ZN	NIPPLE MALE CYL.3 8-1 4 ZN	NIPPELZYL.3 8-1 4 ZN	NIPLE MACHO CIL.3 8-1 4 ZN
9	F03050235R	TUBO 2SN 1 4 FD1 4 F901 4 3500	HYDRAULIC TUBE R2AT 1 4	TUBE HYDRAUL. R2AT 1 4 L 3400	HYDRAUL. ROHR R2AT 1 4 L 3400	TUBO HYDRAULICO R2AT 1 4
10	F03060013R	KIT TUBAZ.IDR.X KIT GF	HYDRAULIC PIPE KIT GF			
11	F03060011R	KIT TUBAZ.IDR.X CP	HYDRAULIC PIPE KIT CP			
12	F01480088R	ROS.G 6,4X12,4X2 FLZNNC-240H	GROWER WASHER D.6	RONDELLE GROWER D.6	SCHEIBE GROWER D.6	ARANDELA GROWER D.6
13	F01020416R	VITE M6X1X55 U5739 8.8ZN	SCR. M6X1X55 U5739 8.8ZN	VIS 6 X55 5739 8.G ZN	SCHRAUBE 6 X55 5739 8.G ZN	TORNILLO 6X55 5739 8.G ZN
15	F01220034R	DADO M10X1,25 D980 8ZN	NUT M10X1,25 D980 8ZN	ECRO.M10X1,25 D980 8 ZB	MUTT.M10X1,25 D980 8 ZB	TUER.M10X1,25 D980 8 ZB
16	F01010038R	VITE M10X1,25X140 U5738 8.8ZN	SCR. M10X1,25X140 U5738 8.8ZN	VIS M10X1,25X140 5738 8.8 ZN	SCHAR.M10X1,25X140 5738 8.8 ZN	TORN. M10X1,25X140 5738 8.8 ZN
17	M07400805R	STAFFA PORTA DEVIATORE	SUPPORT SHUNTER STIRRUP			
18	M58100872R	COMANDO ELETTRICO 12V DC	ELECTRIC CONTROL	COMMANDE ELECTRIQUE	ELEKTRISCHER ANTRIEB	ACCIONAMENTO ELECTRICO
19	F03151042R	DEVIATORE A 6 VIE 2 POSIZIONI	DISTRIBUTOR	DISTRIBUTEUR	VERTEILER	DISTRIBUIDOR
20	F03060186R	KIT TUB.IDR.GUAINA L3000 DIN24	KIT TUB.IDR. STE. L3000 DIN24			
21	F05150325R	CAPPUC.F X INN.M RAP.1 2 ROSS	COVER CONNECT F 1 2 RED	COUVERCLE CONNEXION F 1 2 ROSE	DECKEL W 1 2 SCHNELLKUPP. ROT	PAC PROTECCION F 1 2 ROJO
22	F03080088R	NIPPLO M1 2 SEAL ML10 ZN	NIPPLE M1 2 SEAL ML10 ZN			
23	F03060187R	KIT TUB.IDR.GUAINA L1900 DIN24	KIT TUB.IDR. STE. L1900 DIN24			
24	F03060189R	COMP.TUBAZ.IDR. L1900 DIN24	HYDRAULIC PIPE L1900 DIN24			

**TAV.080**

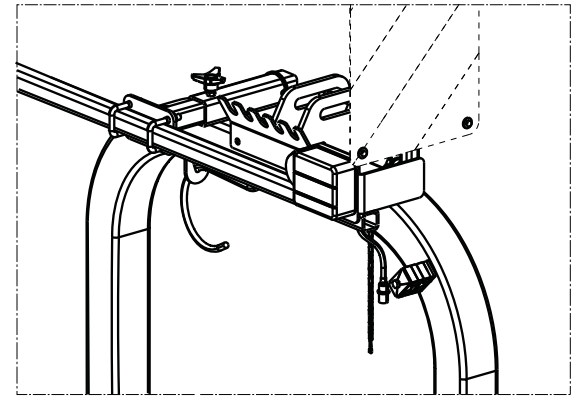
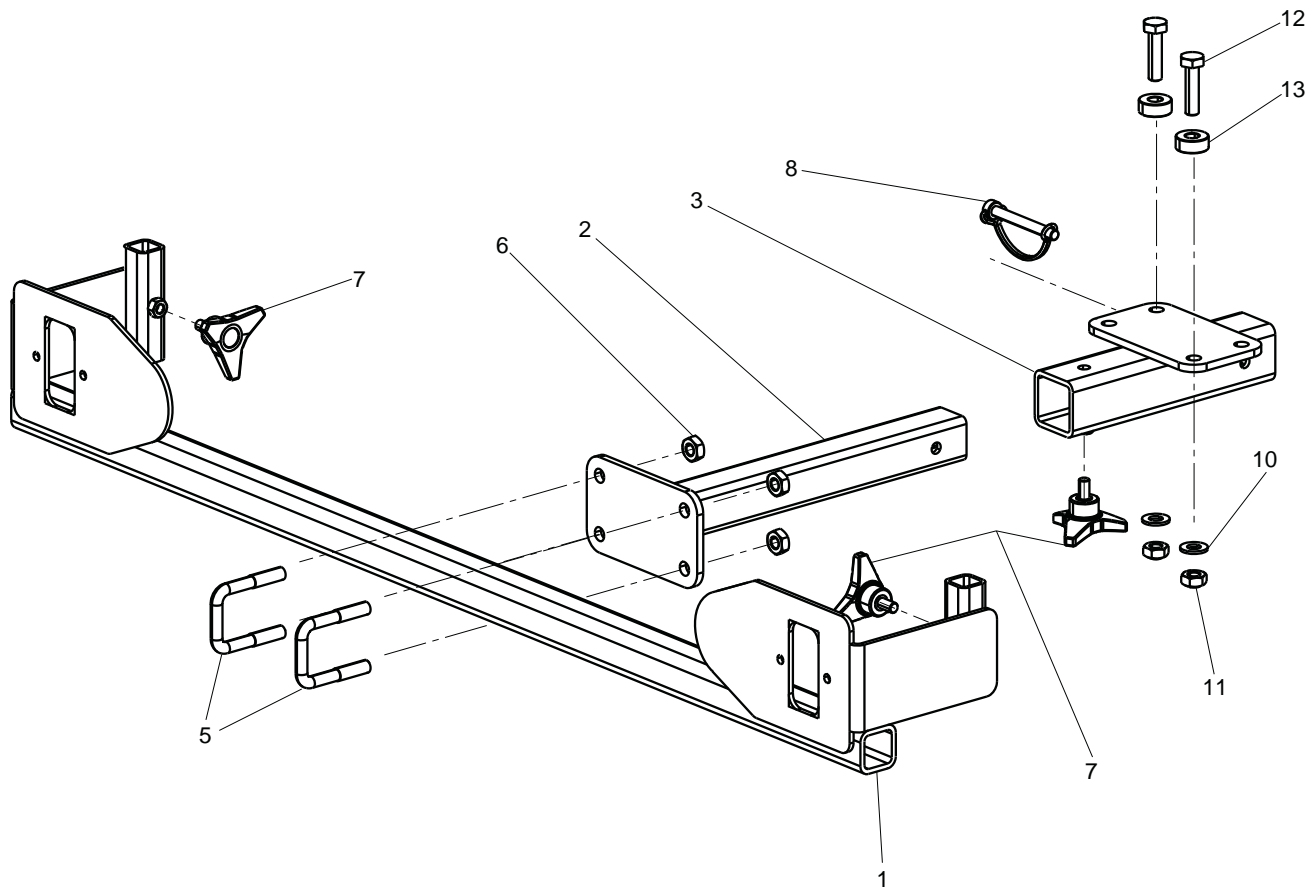

-Posizione in lavoro  
-Position in work

-Posizione in trasporto  
-Position in transport

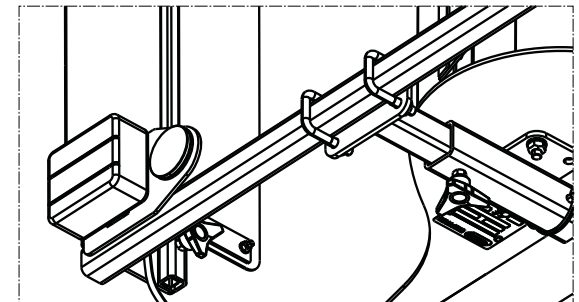
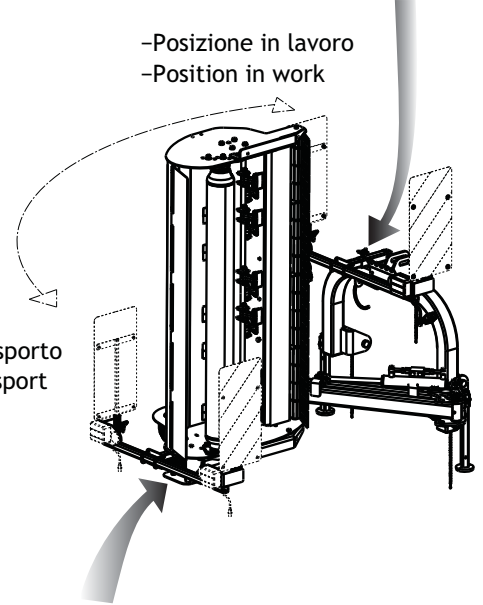

**SUPPORTI TABELLE STRADALI / ROAD KIT SUPPORTS**

**TAV.080**

Pos.	Cod.	Descrizione	Description	Description	Benennung	Description
1	M50400758R	SUPPORTO SEGN.STRAD.BARRA LUCI	ROAD SIGN.SUPPORT			
2	M50400761R	STAFFAGGIO	BRACKET			
3	M50400764R	STAFFAGGIO	BRACKET			
5	F20110706R	CAV.Q.B=35 M=10X1,5 L=60	U BOLT Q.B=35 M=10X1,5 L=60	CAVALIER SUPPORT DISQUE SV	VERBINDUNG SCHEIBENHALTERUNG S	PERNO EN U SOP. DISCO SV
6	F01220033R	DADO M10X1,5 D980 8ZN	NUT M10X1,5 D980 8ZN	ECROU M10X1,5 D980 8ZN	MUTTER M10X1,5 D980 8ZN	TUERCA M10X1,5 D980 8ZN
7	F06220018R	VOLANTINO 3LOBI D.65-M8X15	3-LOBE HANDWHEEL D.65-M8X15			
8	F02200562R	SPINA SICUR.D. 8X70 ZN	SNAP PIN D.8X 70 ZN	FICHE EL. D.8X70 ZN	SCHERSTIFT D.8X 70 ZN	CLAVIJA D.8X 70 ZN
10	F01410064R	ROS.M10 10,5X 20X 2 U6592 ZN	WASHER M10 10,5X20X2 U6592 ZN	RONDEL. M10 10,5X20X2 U6592 ZN	SCHEIBE M10 10,5X20X2 U6592 ZN	ARANDEL.M10 10,5X20X2 U6592 ZN
11	F01220034R	DADO M10X1,25 D980 8ZN	NUT M10X1,25 D980 8ZN	ECRO.M10X1,25 D980 8 ZB	MUTT.M10X1,25 D980 8 ZB	TUER.M10X1,25 D980 8 ZB
12	F01010039R	VITE M10X1,25X40 U5740 10.9ZD	SCR. M10X1,25X40 U5740 10.9ZD	VIS M 10X1,25X40 U5740 10.9ZD	SCHRA.M10X1,25X40 U5740 10.9ZD	TORN. M10X1,25X40 U5740 10.9ZD
13	M33100599R	DISTANZIALE PROTEZIONE ERP.ZPG	SPACER	ENTRETOISE	DISTANZSTUECK	DISTANCIADOR

**TAV.090**

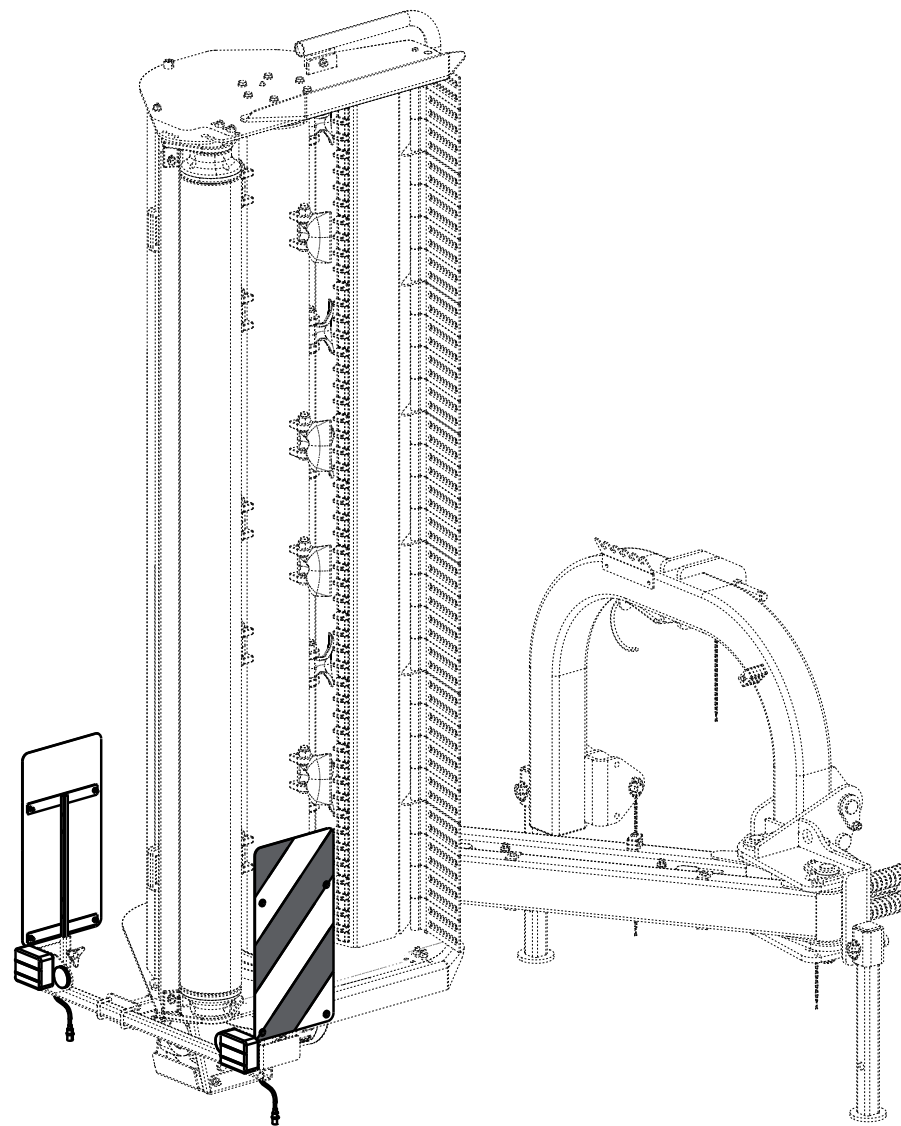
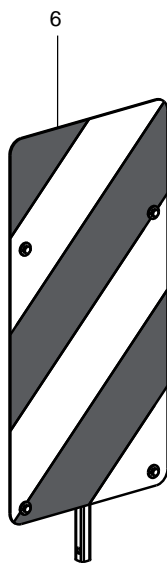
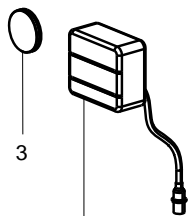
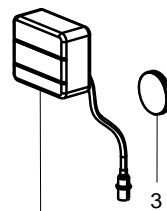
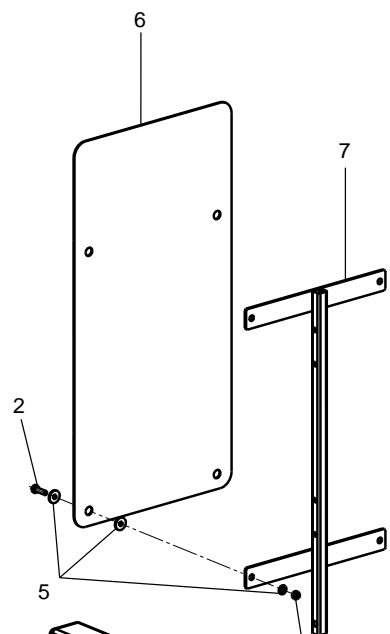

**KIT TABELLE STRADALI G99600020 - ROAD TRANSPORT KIT G99600020**

**TAV.090**

Pos.	Cod.	Descrizione	Description	Description	Benennung	Descripcion
1	F05010822R	KIT FANALI DX-SX CON CAVO	KIT REAR ROAD LIGHTS MOUNTED			
2	F01020404R	VITE M6X1X20 U5739 8.8ZN	SCREW M6X1X20 U5739 8.8ZN	VIS M6X1X20 U5739 8.8ZN	SCHRAUBE M6X1X20 U5739 8.8ZN	TORNILLO M6X1X20 U5739 8.8ZN
3	F05010820R	CATARIFR.TONDO D60 ROSSO	ROUND REFLECTOR D.60 RED			
4	F01220011R	DADO M6X1 D980 8ZN	NUT M6X1 D980 8ZN	ECROU M6X1 D980 8 ZN	MUTTER M6X1 D980 8 ZN	TUERCA M6X1 D980 8 ZN
5	F01420036R	ROS.M6 6,4X 18X1,5 U6593 ZN	WASHER M6 6,4X 18X1,5 U6593 ZN	RONDELLE M6 6,4X18X1,5 U6593ZN	SCHEIBEN M6 6,4X18X1,5U6593 ZN	ARANDELA M6 6,4X18X1,5U6593ZN
6	F05010816R	TABELLE 2 CAR.SPORGENTI IT	WARNING BOARDS 2 IT			
7	G16612070R	TELAIO SUPP.TABELLE STRAD.	FRAME SUPPORT TABLE			

**TAV.100**

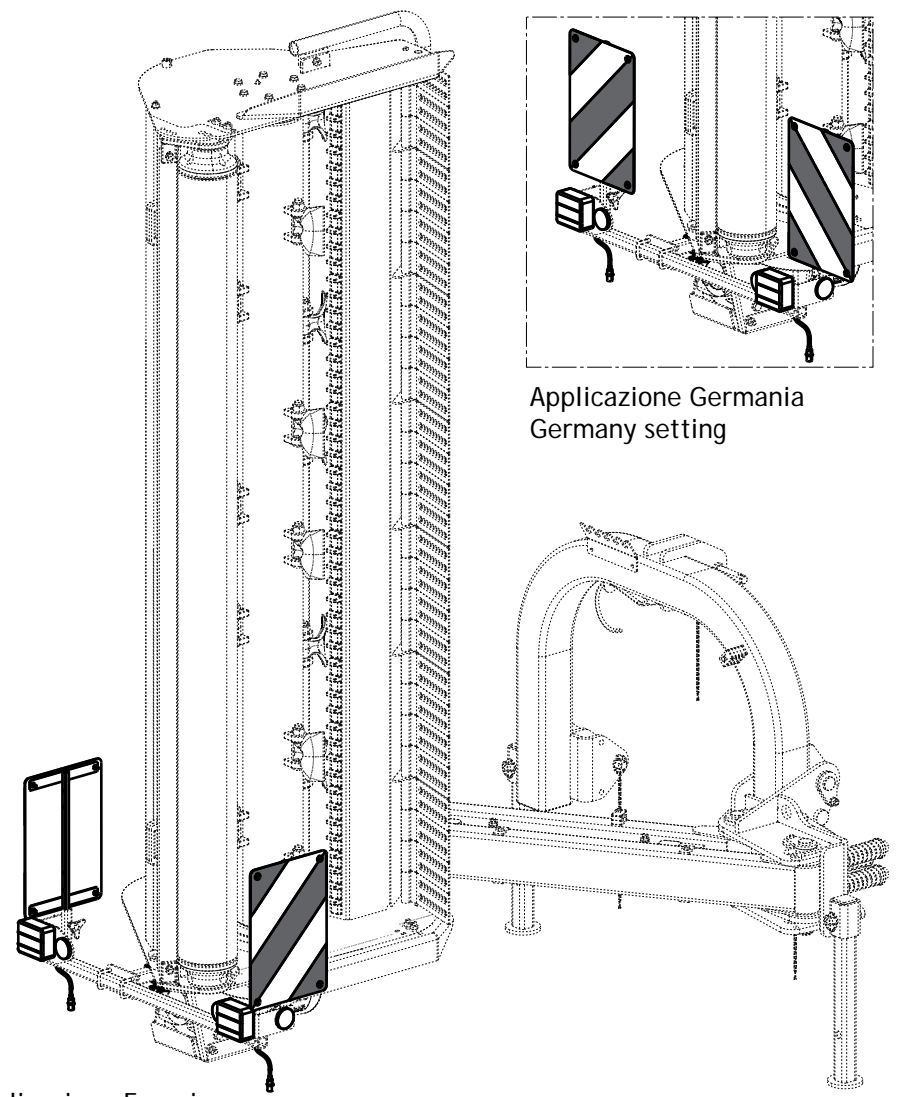
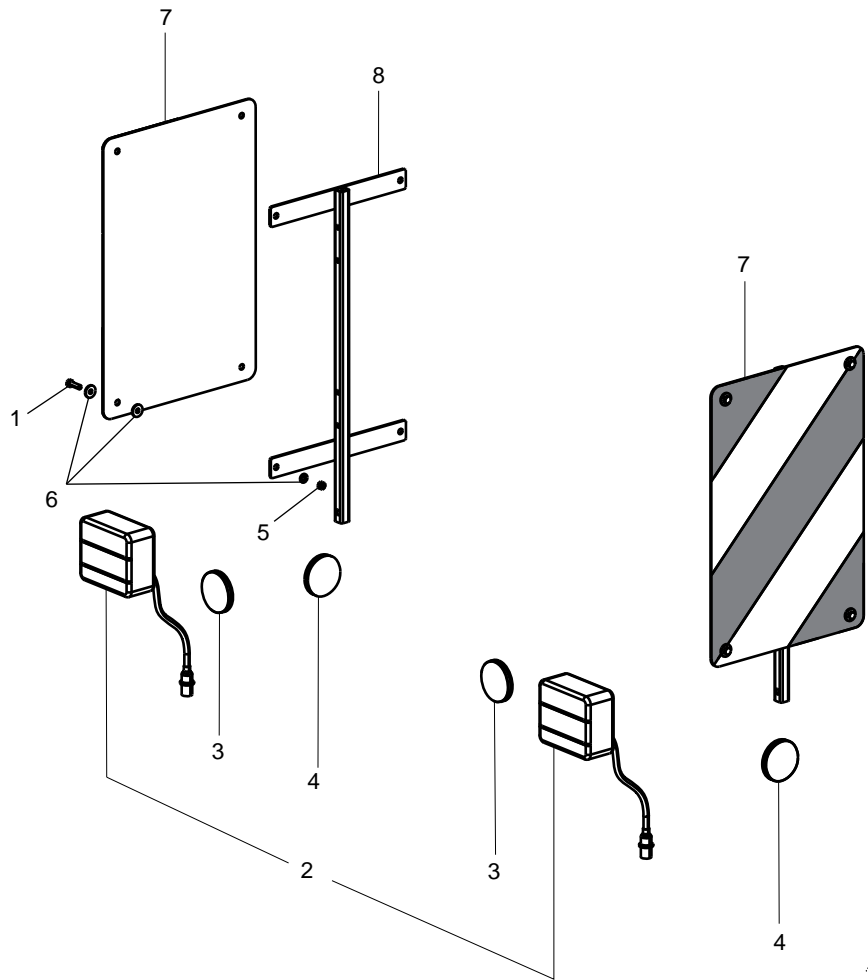

Applicazione Germania  
Germany setting

Applicazione Francia  
France setting



**KIT TABELLE STRADALI G99600021 - ROAD TRANSPORT KIT G99600021**

**TAV.100**

Pos.	Cod.	Descrizione	Description	Description	Benennung	Descripcion
1	F01020404R	VITE M6X1X20 U5739 8.8ZN	SCREW M6X1X20 U5739 8.8ZN	VIS M6X1X20 U5739 8.8ZN	SCHRAUBE M6X1X20 U5739 8.8ZN	TORNILLO M6X1X20 U5739 8.8ZN
2	F05010822R	KIT FANALI DX-SX CON CAVO	KIT REAR ROAD LIGHTS MOUNTED			
3	F05010820R	CATARIFR.TONDO D60 ROSSO	ROUND REFLECTOR D.60 RED			
4	F05010819R	CATARIFR.TONDO D60 GIALLO	ROUND REFLECTOR D.60 YELLOW			
5	F01220011R	DADO M6X1 D980 8ZN	NUT M6X1 D980 8ZN	JAUNE R FLECTEUR ROUND	RUNDFLEKTOR GELB D60	REFLECTOR REDONDO AMARILLO
6	F01420036R	ROS.M6 6,4X 18X1,5 U6593 ZN	WASHER M6 6,4X 18X1,5 U6593 ZN	ECROU M6X1 D980 8 ZN	MUTTER M6X1 D980 8 ZN	TUERCA M6X1 D980 8 ZN
7	F05010817R	TABELLE 2 CAR.SPORGENTI FR-D	WARNING BOARDS 2 FR-DE	RONDELLE M6 6,4X18X1,5 U6593ZN	SCHEIBEN M6 6,4X18X1,5U6593 ZN	ARANDELA M6 6,4X18X1,5U6593ZN
8	G16612070R	TELAIO SUPP.TABELLE STRAD.	FRAME SUPPORT TABLE	TABLEAUX 2 AVERTISSEM. FR-DE	BRETT 2 WARNUNG FR-DE	TABLAS 2 CAR.ADVERT. FR-DE

# TAV.110

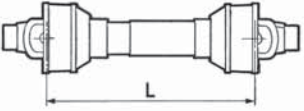
# BONDIOLI

	
7 F08011800 L=1435	GIRAFFETTA SE

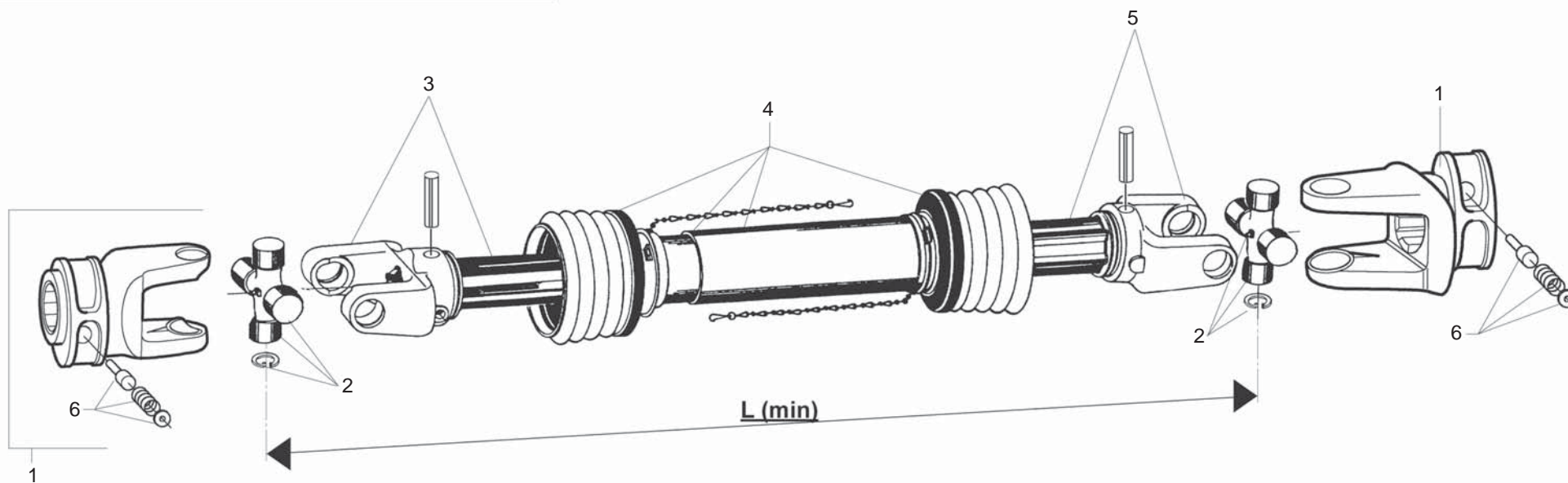



**CARDANO BONDIOLI - BONDIOLI CARDAN SHAFT**

**TAV.110**

Pos.	Cod.	Descrizione	Description	Description	Benennung	Description
1	F08011924R	5720G0381A FORC.S6 1 3 8Z6 BO	5720G0381A BON.FORK S6 1 3 8Z6			
2	F08011925R	41205A001AR40 CROC. COMP. B5	41205A001AR40 SPIDER ASSY B5			
3	F08012155R	FORC.T.INT TUBO SPIN L. 1300	FORC.T.INT PIPE SPIN L. 1300			
4	F08012156R	PROTEZ. COMPLET. L. 1450	PROTECTION			
5	F08012154R	FORC.T.EST TUBO SPIN L. 1300	FORC.T.EST PIPE SPIN L. 1300			
6	F08011910R	403000002R10 PULS.238000061 C.	403000002R10 BUTTON 238000061	POUSSOIR COMPL.	DRUCKKNOPF KOMPL.	PULSADOR COMPL.
7	F08011800R	CAR 35 BO 38Z6 DIR L1659	PTO SHAFT 35 BO 38Z6 DIR L1660			

**USATE SEMPRE RICAMBI ORIGINALI  
ALWAYS USE ORIGINAL SPARE PARTS  
IMMER DIE ORIGINAL-ERSATZTEILE VERWENDEN  
EMPLOYEZ TOUJOURS LES PIECES DE RECHANGE ORIGINALES  
UTILIZAR SIEMPRE REPUESTOS ORIGINALES**



**Servizio Assistenza Tecnica - After Sales Service**

**+39 049 9289960**

**+39 049 9289836**

**Servizio Ricambi - Spare Parts Service**

**+39 049 9289888**

DEALER:



**MASCHIO GASPARDO SpA**

**Registered Office and Production Plant**

Via Marcello, 73 - 35011 Campodarsego (Padova) - Italy

Tel. +39 049 9289810

Fax +39 049 9289900

info@maschio.com

www.maschionet.com

**MASCHIO GASPARDO SpA**

**Production Plant**

Via Mussons, 7 - 33075 Morsano al Tagliamento (PN) - Italy

Tel. +39 0434 695410

Fax +39 0434 695425

info@gaspardo.it

**MASCHIO DEUTSCHLAND GMBH**

Äußere Nürnberger Straße 5

D - 91177 Thalmässing - Deutschland

Tel. +49 (0) 9173 79000

Fax +49 (0) 9173 790079

dialog@maschio.de

www.maschionet.de

**MASCHIO GASPARDO North America**

112 3rd Avenue East

DeWitt, IA 52742 (USA)

Phone: (563) 659-6400

Fax: (563) 659-6404

e-mail: info@maschio.us

**MASCHIO FRANCE Sarl**

1 rue Denis Papin ZA

F - 45240 La Ferte St. Aubin

France

Tel. +33 (0) 2.38.64.12.12

Fax +33 (0) 2.38.64.66.79

info@maschio.fr

**MASCHIO-GASPARDO ROMANIA S.R.L.**

Strada Înfrâții, F.N.

315100 Chisineu-Cris (Arad) -România

Tel. +40 257 307030

Fax +40 257 307040

info@maschio.ro

**ООО МАСКИО-ГАСПАРДО РУССИЯ**

404126, Россия, Волгоградская область,  
г.Волжский, ул.Пушкина, 117 \*б\*.

Тел.: +7 8443 203100

факс: +7 8443 203101

e-mail: info@maschio.ru

http://www.maschionet.com

**MASCHIO IBERICA S.L.**

**MASCHIO-GASPARDO POLAND**

**MASCHIO-GASPARDO UCRAINA**

**GASPARDO-MASCHIO TURCHIA**

**MASCHIO-GASPARDO CINA**

**MASCHIO-GASPARDO INDIA**

**MASCHIO-GASPARDO KOREA**