

MASCHIO GASPARDO S.p.A.

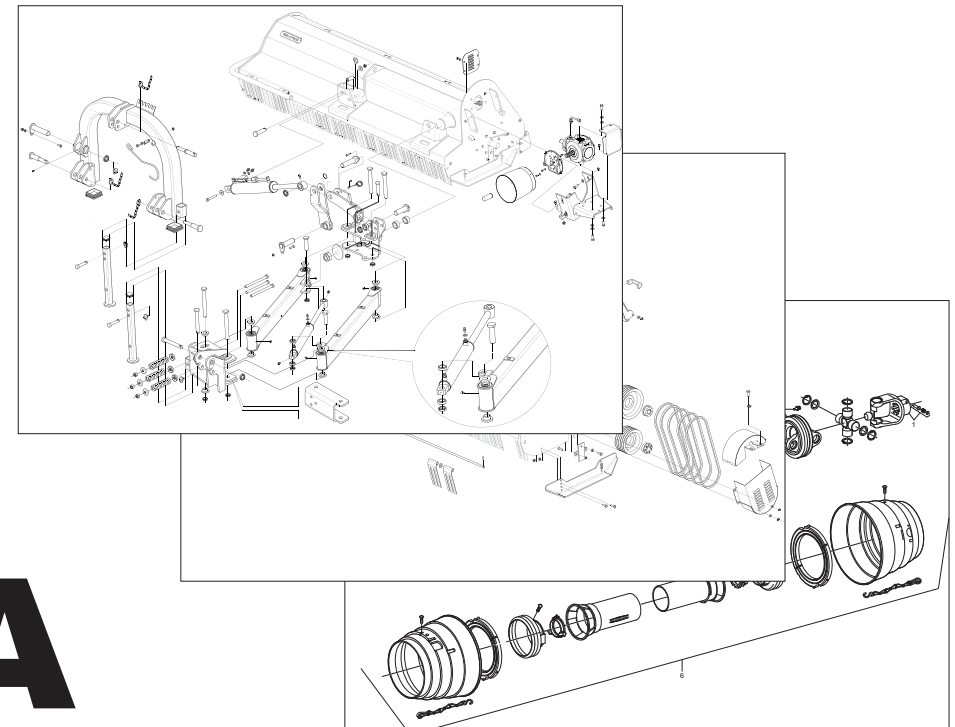

GIRAFFONA

Cod: F07011329 2010-09

- *) Valido per Paesi UE
- *) Valid for EU member countries
- *) Valable dans les Pays UE
- *) Gilt für EU-Mitgliedsländer
- *) Válido para Países UE

- IT** PARTI DI RICAMBIO
- EN** SPARE PARTS
- DE** ERSATZTEILE
- FR** PIÈCES DÉTACHÉES
- ES** PIEZAS DE REPUESTO

ITALIANO	ENGLISH	DEUTSCH	FRANÇAIS	ESPAÑOL
PARTI DI RICAMBIO	SPARE PARTS	ERSATZTEILE	PIECES DÉTACHÉES	RESPUESTOS
<p>Le ordinazioni delle parti di ricambio vanno fatte presso i nostri concessionari di zona e devono essere sempre corredate dalle seguenti indicazioni:</p> <ul style="list-style-type: none"> - Tipo, modello e numero di matricola dell'attrezzatura. Tali dati sono stampigliati nell'apposita targhetta di cui è dotata ogni attrezzatura. - Numero di codice della parte richiesta rilevabile dal catalogo ricambi. - Descrizione del particolare e quantità richiesta. - Numero della tavola. - Mezzo di trasporto. Nel caso questa voce non sia specificata, la Ditta Costruttrice, pur dedicando a questo servizio una particolare cura, non risponde di eventuali ritardi di spedizione dovuti a cause di forza maggiore. Le spese di trasporto si intendono sempre a carico del destinatario. La merce viaggia a rischio e pericolo del committente anche se venduta franco destino. <p>NOTA: Il termine (Dx) Destro o (Sx) Sinistro della macchina o di parti di essa, è inteso guardando la macchina dalla parte posteriore. Le eccezioni saranno indicate.</p>	<p><i>Orders must be transmitted through our area dealers and should always include the following indications:</i></p> <ul style="list-style-type: none"> - Type, model and serial number of the machine. <i>These data are punched on the data plate with which every implement is equipped.</i> - Code number of the required spare part. <i>This will be found in the spare parts catalogue.</i> - Description of the part and required quantity. - Table number. - Means of dispatch. <i>If this item is not indicated, the Manufacturer, while dedicating particular care to this service, shall not be held responsible for delays in delivery caused by cases of force majeure. Transport expenses shall always be at the consignee's charge. The goods travel at the purchaser's risk and peril even when sold ex destination.</i> <p>NOTE: <i>The symbols (Dx) right and (Sx) left, concerning the machine or single parts of it, are referred, as in the figure, to a rear view of them. Exceptions will be indicated.</i></p>	<p>Die Bestellungen müssen bei unseren Gebietshändlern aufgegeben werden. Bei der Bestellung sind stets die folgenden Angaben zu machen:</p> <ul style="list-style-type: none"> - Typ, Modell und Serien-Nummer des Geräts. Diese Daten stehen auf dem Typenschild, mit dem jedes Gerät versehen ist. - Artikel Nr. der erforderlichen Ersatzteile. Diese stehen im Ersatzteil-Katalog. - Beschreibung des Ersatzteils und die erforderliche Stückzahl. - Tafelnummer. - Versandmittel. Wenn dieser Punkt nicht spezifiziert wird, haftet die Herstellerfirma nicht für etwaigen Lieferverzug aufgrund höherer Gewalt, auch wenn er diesen Service besonders aufmerksam abwickelt. Die Frachtkosten gehen dagegen immer zu Lasten des Empfängers. Die Ware reist auf Gefahr und Risiko des Auftraggebers, auch wenn frei Haus Verkauft vereinbart worden ist. <p>N.B.: Die Merkzeichen (Dx) rechts und (Sx) links betreffen eine rückwärtige Aussicht der Maschine oder Teile von ihr (siehe Bild). Ausnahmen werden gezeigt.</p>	<p><i>Les ordres doivent être effectués auprès de nos concessionaires de zone en précisant les indications suivantes:</i></p> <ul style="list-style-type: none"> - Type, modèle et numéro de série de la machine. <i>Ces données sont gravées sur la plaque d'identification de chaque outil.</i> - Numéro de code de la pièce détachée indiqué sur le catalogue des pièces détachées. - Description de la pièce et quantité requise. - Numéro de plan. - Moyen d'expédition. <i>Si cette rubrique n'est pas indiquée, le Constructeur, bien que soucieux de ce service, ne répond pas des retards d'expédition pour des causes de force majeure. Les frais de transport sont toujours à la charge du destinataire. La marchandise voyage aux risques et périls de l'acheteur même si vendue franco de port.</i> <p>N.B.: <i>Les références (Dx) droit et (Sx) gauche de la machine ou des parties de la même, est entendue, comme de la figure, en regardant la machine de derriere dans le sens de marche.</i></p>	<p>Los pedidos han de efectuarse en nuestros concesionarios de zona y deben incluir siempre las siguientes indicaciones:</p> <ul style="list-style-type: none"> - Tipo, modelo y número de matrícula del equipo. Dichos datos están impresos en la relativa placa presente en el equipo. - Número de código de la parte requerida presente en el catálogo respuestas. - Descripción de la pieza y cantidad requerida. - Numero de ilustración. - Medio de transporte. En caso que este ítem no esté especificado, el Fabricante, aún prestando la debidas consideraciones para este aspecto, no responde por eventuales retardos de env'o debidos a causas de fuerza mayor. Los gastos de transporte se consideraran siempre a cargo del destinatario. La mercadería viaja bajo riesgo y peligro del comprador, incluso cuando se vende franco destino. <p>N.B.: La referencia (Dx) derecha o (Sx) izquierda de la máquina o de sus componentes, se entiende, como en la figura, mirando la máquina por la parte trasera. Se indicarán las excepciones.</p>

INDICE

<i>N° Tavola</i>	<i>Descrizione</i>	<i>Pagina</i>
TAV. 010	Telaio e terzo punto.....	4
TAV. 020	Moltiplicatore 540 rpm - Comer.....	8
TAV. 030	Moltiplicatore 540 rpm - Bondioli.....	10
TAV. 040	Trasmissione.....	12
TAV. 050	Rotore.....	14
TAV. 060	Rullo.....	16
TAV. 070	Impianto idraulico.....	18
TAV. 080	Cardano Walterscheid.....	20
TAV. 090	Cardano omocinetico Walterscheid.....	22

INDEX

<i>N° Table</i>	<i>Description</i>	<i>Page</i>
TAV. 010	Frame and 3rd point hitch.....	4
TAV. 020	Gearbox 540 rpm - Comer.....	8
TAV. 030	Gearbox 540 rpm - Bondioli.....	10
TAV. 040	Transmission.....	12
TAV. 050	Rotor.....	14
TAV. 060	Roller.....	16
TAV. 070	Hydraulic plant.....	18
TAV. 080	Walterscheid constant velocity PTO shaft.....	20
TAV. 090	Walterscheid PTO shaft.....	22

* = Versione COMER/ COMER version

** = Versione BONDIOLI / BONDIOLI version

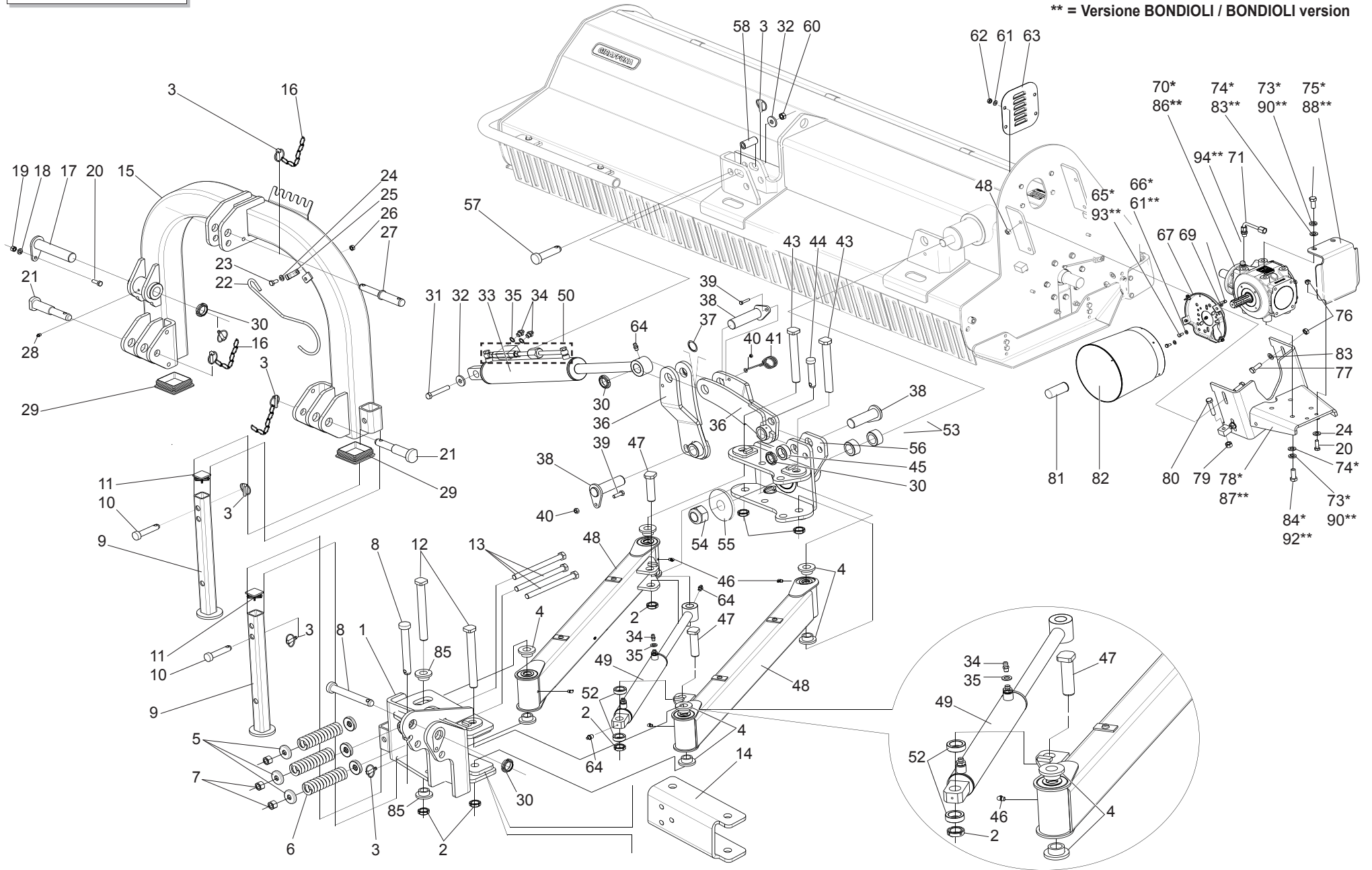

TELAIO E TERZO PUNTO / FRAME AND 3rd POINT HITCH

TAV. 010

Pos.	Cod.	Descrizione	Description	Benennung	Description	Descrpcion
1	M50400570	COMPOSTO ATTACCO 3° PUNTO	LINKAGE 3RD POINT	DREIPUNKTVERBINDUNG	ATTELAGE 3EME POINT	ATAQUE 3 PUNTO
2	F02010111	GHIERA AU.GUP M30X1,5 T.4H ZN	SELF LOCKING NUT M30X1,5	SELBSTSP. NUTMUTTER M30X1,5	COLLIER AUTOBL. M30X1,5	VIROLA AUTOBL. M30X1,5
3	F02200529	SPINA SCATTO D.11 ZN	SNAP PIN D.11	EINRASTSTIFT D.11	FICHE A DETENTE D.11	CLAVIJA DE MUELLE D.11
4	M07400929	BOCCOLA D=30 D=40 L=30	BUSHING D=30 D=40 L=30	BUECHSE D=30 D=40 L=30	BOUCLE D=30 D=40 L=30	ARANDELA D=30 D=40 L=30
5	G16610430	FONDELLO	BOTTOM	BODENSCHLEIBE	CULOT	FONDO
6	M50400567	MOLLA	SPRING	FEDER	RESSORT	MUELLE
7	F01200136	DADO M20X 1,5 U5587 6S ZN	NUT M20X1,5	MUTTER M20X1,5	ECROU M20X1,5	DADO M20X1,5
8	F20100077	PERNO D=28 L=194 ZN	PIN D=28 L=200	STIFT D=28 L=200	GOUJON D=28 L=200	PERNO D=28 L=200
9	M12400590	PIEDINO L=550	SUPPORT	FRASE STANDER	SUPPORT FRAISE	SOPORTE FRESADORA
10	F20100049	PERNO D22 L86 C43 ZN	PIN D.22	BOLZEN D.22	GOUJON D.22	PERNO D.22
11	F20120349	PUNTALE Q.50 ALETT.POLIT.NERO	CAP	DECKEL	BOUCHON	CORCHO
12	M50400568	PERNO D=30 L=263	PIN D=30 L=263	STIFT D=30 L=263	GOUJON D=30 L=263	PERNO D=30 L=263
13	F01010181	VITE M20X1,5X250 U5738 8.8 ZN	BOLT M20X1,5X250	SCHRAUBE M20X1,5X250	VIS M20X1,5X250	TORNILLO M20X1,5X250
14	M50400569	PIASTRA ROTAZIONE	PLATE	PLATTE	PLAQUETTE	PLAQUITA
15	M50400523	CASTELLO 3° PUNTO	COMPLETE 3RD POINT	3. PUNKT KOMPLETT	3EME POINT COMPL.	TERCER PUNTO COMPL.
16	M63112581	ASSIEME CATENELLA L.333 ZN	CHAIN	KETTE	CHAINE	CADENA
17	M50400591	PERNO FLOTTANTE D=40 L=195	PIN D=40 L=195	STIFT D=40 L=195	GOUJON D=40 L=195	PERNO D=40 L=195
18	F01480123	ROS.G 12,5X22,9X 4 EX.C70 ZN	WASHER M12 ZGP EXTRA P.	UNTERLEGSCHLEIBE M12 ZGP EXTRA	RONDELLE M12 ZGP EXTRA P.	ARANDELA M12 ZGP EXTRA P.
19	F01200073	DADO M12X1,25 U5587 6S ZN	NUT M12X1,25 U5587 6S ZN	MUTTER M12X1,25	ECROU M12X1,25	TUERCA M12X1,25
20	F01010288	VITE M12X1,25X35 U5740 8.8 ZN	SCREW M12X1,25X35 U5740 8.8 ZN	SCHR.M12X1,25X35 U5740 8.8 ZN	VIS M12X1,25X35 U5740 8.8 ZN	TORN.M12X1,25X35 U5740 8.8 ZN
21	M21400563	PERNO ATTACCO BARRA.2°-3° C.	PIN FOR BAR LINKAGE	VERB.BOLZEN SCHUTZHOLM	GOUJON ATTELAGE BARRE	PERNO ATAQUE BARRA
22	F20120400	GANCIO SOSTEGNO CARDANO	SHAFT HOOK	GELENKWELLE - HACKEN	SUPPORT CARDAN	SOPORTE CARDAN
23	F01010281	VITE M12X1,25X25 U5740 8.8 ZN	BOLT M 12X1,25X25	SCHRAUBE M 12X1,25X25	VIS M 12X1,25X25	TORNILLO M 12X1,25X25
24	F01410076	ROS.M12 13X 24X2,5 U6592 ZN	WASHER D12 U6592 ZN	SCHLEIBE D12 U6592 ZN	RONDELLE D12 U6592 ZN	ARANDELA D12 U6592 ZN
25	F20120401	FASCETTA FERMA CARDANO ZN	LOCK	BLOCKIERUNG	ARRET	FAJA SEGURO DEL CARDÁN
26	F01220047	DADO M12X1,25 D980 8 ZN	NUT M12X1,25 D980 8 ZN	MUTTER M12X1,25 D980 8 ZN	ECROU M12X1,25 D980 8 ZN	TUERCA M12X1,25 D980 8 ZN
27	F20100130	PERNO ATTACCO TIRANTE	PIN	STIFT	GOUJON	PERNO
28	F01100061	ING.M10X1 7663-A 9SMNPB28 ZN	GREASE NIPPLE M10X1 7663-A ZN	SCHMIERBUECHSE M10X1 7663-A ZN	GRAISSEUR M10X1 7663-A ZN	ENGRASADOR M10X1 7663-A ZN
29	F05100163	TAPPO*PLT X TUBO	CAP	DECKEL	BOUCHON	CORCHO
30	F02010034	GHIERA AU.GUK M40X1,5 T.4H ZN	SELF LOCKING NUT	SELBSTSP. NUTMUTTER	COLLIER AUTOBL.	VIROLA AUTOBL.
31	F01010124	VIT.M16X 1,5X100 U5738 8.8 ZN	BOLT M16X1,5X100	SCHRAUBE M16X1,5X100	VIS M16X1,5X100	TORNILLO M16X1,5X100
32	F01500023	ROS. 17 X45X6 D6340 C50 ZD	ELASTIC DISK	ELASTISCHE SCHEIBE	DISQUE ELASTIQUE	DISCO ELASTICO
33	M50400545	COMP. MART.IDR.A=80 C=400 L712	JACK SCREW ASSY	SPINDELVERSTELLUNGSTEIL	VERIN	MARTINETE
34	F03150310	NIPPLO MM CIL-CIL 3/8-1/4 ZN	NIPPLE CYL.MALE3/8-1/4 ZN	NIPPELZYL 3/8-1/4 ZN	NIPPLE MALE CYL.3/8-1/4 ZN	NIPLE MACHO CIL.3/8-1/4 ZN
35	F03100023	ROS. 17 X23X1,5 RAME -3/8"	WASHER 17X 23X1,5 RAME -3/8"	SCHLEIBE 17X 23X1,5 RAME -3/8"	RONDELLE 17X 23X1,5 RAME -3/8"	ARANDELA 17X 23X1,5 RAME -3/8"
36	M50400560	COMPOSTO BIELLA	CONNECTING ROD	PLEUELSTANGE	BIELLE	BIELA
37	M48000307	ANELLO RINF.40X50X1,5 C70 TEMP	STIFFENER RING 40X50X1,5 C70	SEEGER RING 40X50X1,5 C70	BAGUE DE RENFORCEM. 40X50X1,5	ANILLO REFUERZO 40X50X1,5
38	M50400578	PERNO D=40 L=130	PIN D=40 L=130	STIFT D=40 L=130	GOUJON D=40 L=130	PERNO D=40 L=130
39	F01020450	VITE M 8X1,25X40 U5739 8.8 ZN	BOLT M 8X40	SCHRAUBE M 8X40	VIS M 8X40	TORNILLO M 8X40
40	F01220022	DADO M 8X1,25 D980 8 ZN	NUT M8X 1,25 D980 8 ZN	MUTTER M8X 1,25 D980 8 ZN	ECROU M8X 1,25 D980 8 ZN	TUERCA M8X 1,25 D980 8 ZN
41	M21100654	MOLLA PER TUBO SPANDICONC.	SPRING	FEDER	RESSORT	RESORTE
43	M50400551	PERNO D=30 L=207	PIN D=30 L=207	STIFT D=30 L=207	GOUJON D=30 L=207	PERNO D=30 L=207
44	F20100063	PERNO D25 L91 C40 ZN	BOLT D25 L91 C40 ZN	BOLZEN D25 L91 C40 ZN	BOULON D25 L91 C40 ZN	PERNO D25 L91 C40 ZN
45	M09400578	DISTANZIALE D=60 D=40.5 L=22	SPACER	DISTANZSTUECK	ENTRETOISE	DISTANCIADOR
46	F01100063	ING.M10X1 7663-C 9SMNPB28 ZN	GREASE NIPPLE M10X1	SCHMIERBUECHSE M10X1	GRAISSEUR M10X1	ENGRASADOR M10X1
47	M07400598	COMP.PERNO D=30 L=109	PIN D=30 L=109	STIFT D=30 L=109	GOUJON D=30 L=109	PERNO D=30 L=109
48	M50400520	PARALLELOGRAMMA GIRAFFONA	ARM	ARM	BRAS	BRAZO
49	M50400550	COMP. MART.IDR.A=60 C=380 L630	JACK SCREW ASSY	SPINDELVERSTELLUNGSTEIL	VERIN	MARTINETE
50	F03151318	KIT VAL.BLOC.UNID.X M50400545*	KIT VALVE BLOCK.	SPERRVENTIL	VANNE D'ARRÊT	KIT VALVULA DE BLOQUE

----- CONTINUA A PAGINA SEGUENTE -----

----- CONTINUED ON NEXT PAGE -----

* = Versione COMER/ COMER version
 ** = Versione BONDIOLI / BONDIOLI version

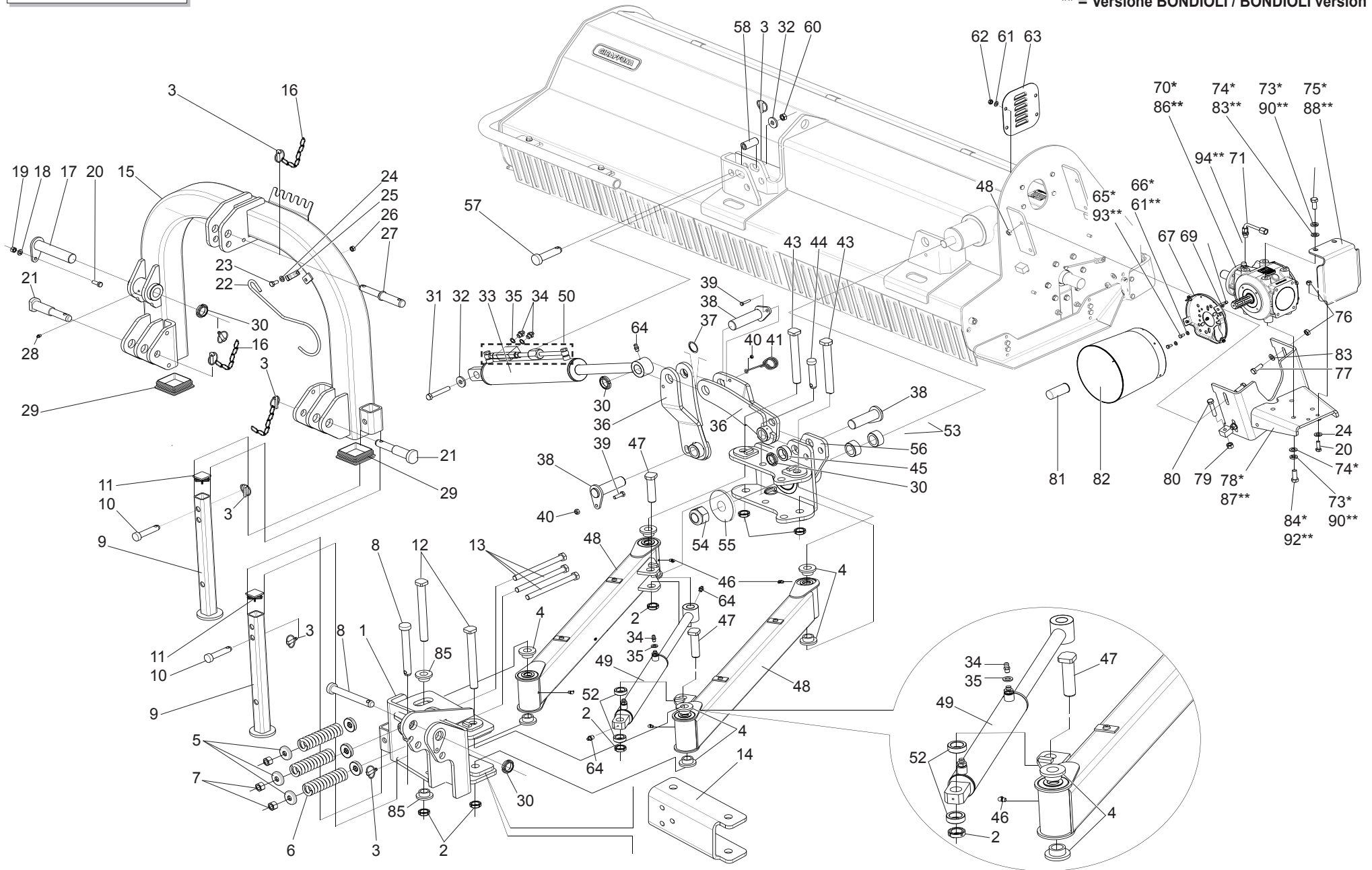

TELAIO E TERZO PUNTO / FRAME AND 3rd POINT HITCH

TAV. 010

Pos.	Cod.	Descrizione	Description	Benennung	Description	Description
<p>----- CONTINUA DA PAGINA PRECEDENTE ----- ----- CONTINUED FROM PRECEDING PAGE -----</p>						
52	M23400528	ROSETTA D=48,3 D=32,5 L=15	WASHER D=48,3 D=32,5 L=15	SCHEIBE D=48,3 D=32,5 L=15	ROSETTE D=48,3 D=32,5 L=15	ARANDELLA D=48,3 D=32,5 L=15
53	F04100110	BOCCOLA D=105 D=100 L=60	BUSHING D=105 D=100 L=60	BUECHSE D=105 D=100 L=60	BOUCLE D=105 D=100 L=60	ARANDELA D=105 D=100 L=60
54	F01230179	DADO M42X 3 D982 8 ZN	SELF LOCKING NUT M42X3	SELBSTSPERR.MUTTER M42X3	ECROU AUTOBL. M42X3	DADO AUTOBL. M42X3
55	M50400555	ROSETTA DI BLOCCAGGIO	PLANE WASHER	SCHEIBE	RONDELLE	ARANDELA
56	M50400535	GIUNTO MOVIMENTAZIONE	JOINT	VERBINDUNG	JOINT	JUNTA
57	F20100078	PERNO D28 L93 C43 ZN	PIN D.28	BOLZEN D.28	GOUJON D.28	PERNO D.28
58	M50400556	DISTANZIALE D=30 D=20 L=65	SPACER D=30 D=20 L=65	DISTANZST.D=30 D=20 L=65	ENTRETOISE D=30 D=30 L=65	DISTANCIAD.D=30 D=20 L=65
60	F01220070	DADO M16X 1,5 D980 8 ZN	NUT M16X 1,5 D980 8 ZB	MUTT.M16X 1,5 D980 8 ZB	ECRO.M16X 1,5 D980 8 ZB	TUER.M16X 1,5 D980 8 ZB
61	F01410064	ROS.M10 10,5X 20X 2 U6592 ZN	WASHER M10 10,5X20X2 U6592 ZN	SCHEIBE M10 10,5X20X2 U6592 ZN	RONDELL.M10 10,5X20X2 U6592 ZN	ARAND. M10 10,5X20X2 U6592 ZN
62	F01220034	DADO M10X1,25 D980 8 ZN	NUT M10X1,25 D980 8 ZB	MUTT.M10X1,25 D980 8 ZB	ECRO.M10X1,25 D980 8 ZB	TUER.M10X1,25 D980 8 ZB
63	M07400939	CARTER FIANCATA	CARTER	GEHAEUSE	CARTER	CARTER
64	F01100011	INGRAS.A SFERA M6X1 DRITTO A	SPHERE NIPPLE M6X1/A	KUGELFETTBSCHSE M6X1/A	GRAISSEUR A BILLES M6X1/A	ENGRAS. DE ESFERAS M6X1/A
65	F01020432	VITE M 8X1,25X16 U5739 8.8 ZN	BOLT M 8X16	SCHRAUBE M 8X16	VIS M 8X16	TORNILLO M 8X16
66	F01410051	ROS.M8 8,4X 17X1,6 U6592 ZN	WASHER M8 8,4X17X1,6 U6592 ZN	SCHEIBE M8 8,4X17X1,6 U6592 ZN	RONDEL. M8 8,4X17X1,6 U6592 ZN	ARANDELA M8 8,4X17X1,6 U6592 ZN
67	M37100106	ATTACCO PROTEZIONE	PROTECTION SUPPORT	GELENKWELLENSCHUTZ HALTER	SUPPORT PROTECTION CARDAN	SOPORTE PROTECCION CARDANICO
68	F01020403	VITE M 6X 1X 16 U5739 8.8 ZN	SCREW M6X1X16 U5739 8.8 ZN	SCHRAUBE M6X1X16 U5739 8.8 ZN	VIS M6X1X16 U5739 8.8 ZN	TORNILLO M6X1X16 U5739 8.8 ZN
69	F01410037	ROS.M6 6,4X12,5X1,6 U6592 ZN	PLANE WASHER D.6	SCHEIBE D.6	RONDELLE D.6	ARANDELA D.6
70	M50400201	SCATOLA MOLTIPL. GFN MASCHIO	GEARBOX	WECHSELGETRIEBEGEHAEUSE	BOITE DE VITESSE	CAJA CAMBIO
71	M07400216	PROLUNGA*SFIATO 90°	BREATHER PLUG 90°	ENTLUEFTERSTOPFEN 90°	BOUCHON DE SOUPIRAIL 90°	TAPON RESPIRADERO 90°
72	F01010337	VITE M16X1,5X 35 U5740 8.8 ZN	BOLT M 16	SCHRAUBE M 16	VIS M 16	TORNILLO M 16
73	F01480145	ROS.G 17X29 X 5 EX.C70 ZN	GROWER WASHER 17X29	SCHEIBE GROWER 17X29	RONDELLE GROWER 17X29	ARANDELA GROWER 17X29
74	F01410100	ROS.M16 17X 30X 3 U6592 ZN	WASHER M16 17X30X3 U6592 ZN	SCHEIBE M16 17X30X3 U6592 ZN	RONDELLE M16 17X30X3 U6592 ZN	ARANDELA M16 17X30X3 U6592 ZN
75	M50400527	PROTEZIONE LATERALE	SIDE PROTECTION	SEITENSCHUTZ	PROTECTION LAT.	PROTECCION LATERAL
76	F01220059	DADO M14X 1,5 D980 8 ZN	NUT M14X 1,5 D980 8 ZB	MUTTER M14X 1,5 D980 8 ZB	ECROU M14X 1,5 D980 8 ZB	TUERCA M14X 1,5 D980 8 ZB
77	F01010318	VITE M14X 1,5X40 U5740 8.8 ZN	BOLT M 14X1,5X40	SCHRAUBE M 14X1,5X40	VIS M 14X1,5X40	TORNILLO M 14X1,5X40
78	M50400510	SUPPORTO SCATOLA	BRACKET	HALTERUNG	SUPPORT	SOPORTE
79	F01200089	DADO M14X 1,5 U5587 6S ZN	NUT M14X 1,5 U5587 6S ZB	MUTTER M14X 1,5 U5587 6S ZB	ECROU M14X 1,5 U5587 6S ZB	TUERCA M14X 1,5 U5587 6S ZB
80	F01010323	VITE M14X1,5 X70 U5740 8.8 ZN	BOLT M 14X1,5X70	SCHRAUBE M 14X1,5X70	VIS M 14X1,5X70	TORNILLO M 14X1,5X70
81	M38100146	MANICOTTO PROTEZIONE PDF	P.T.O. PROTECTION	ZAPFWELLENSCHUTZ P.T.O.	MANCHON DE PROTECTION P.T.O.	MANGUITO PROTECCION P.T.O.
82	M68100106	PROTEZIONE CARDANO	CARDAN PROTECTION	GELENKWELLENSCHUTZ	PROTECTION CARDAN	PROTECCION CARDANICO
83	F01410088	ROS.M14 15X 28X2,5 U6592 ZN	WAS.M14 15X 28X2,5 U6592 ZB	SCH.M14 15X 28X2,5 U6592 ZB	RON.M14 15X 28X2,5 U6592 ZB	ARA.M14 15X 28X2,5 U6592 ZB
84	F01010339	VITE M16X1,5X 40 U5740 8.8 ZN	BOLT M 16X1,5X40	SCHRAUBE M 16X1,5X40	VIS M 16X1,5X40	TORNILLO M 16X1,5X40
85	M50400574	BOCCOLA D=65 D=30,3 L=18	BUSHING D=65 D=30,3 L=18	BUECHSE D=65 D=30,3 L=18	BOUCLE D=65 D=30,3 L=18	ARANDELA D=65 D=30,3 L=18
86	M50400206	SCATOLA MOLTIPL. GFN BONDIOLI*	GEARBOX	WECHSELGETRIEBEGEHAEUSE	BOITE DE VITESSE	CAJA CAMBIO
87	M50400706	SUPPORTO SCATOLA	GEARBOX SUPPORT	WECHSELGETR. HALTERUNG	SUPPORT BOITE DE VITESSE	SOPORTE CAJA CAMBIO
88	M50400705	PROTEZIONE LATERALE	SIDE PROTECTION	SEITENSCHUTZ	PROTECTION LAT.	PROTECCION LATERAL
89	F01020539	VITE M14X2X25 U5739 8.8 ZN	SCREW M14X2X25 U5739 8.8 ZN	SCHRAUBE M14X2X25 U5739 8.8 ZN	VIS M14X2X25 U5739 8.8 ZN	TORNILLO M14X2X25 U5739 8.8 ZN
90	F01480134	ROS.G 15X26,5X4,5 EX.C70 ZN	GROWER 15X26,5X4,5 EX.C70 ZN	SCHEIBE GROWER 15X26,5X4,5	RONDELLE GROWER 15X26,5X4,5	ARANDELA GROWER 15X26,5X4,5
92	F01020540	VITE M14X2X30 U5739 8.8 ZN	BOLT M 8X40	SCHRAUBE M 8X40	VIS M 8X40	SCHRAUBE M 8X40
93	F01020470	VITE M10X1,5X20 U5739 8.8 ZN	BOLT M 10X20	SCHRAUBE M 10X20	VIS M 10X20	TORNILLO M 10X20
94	F03151040	PROLUNGA M-F 3/8 ESA.L=22 L=35	EXTENSION	VERLÄNGERUNG	EXTENSION	PROLONGA

COMER

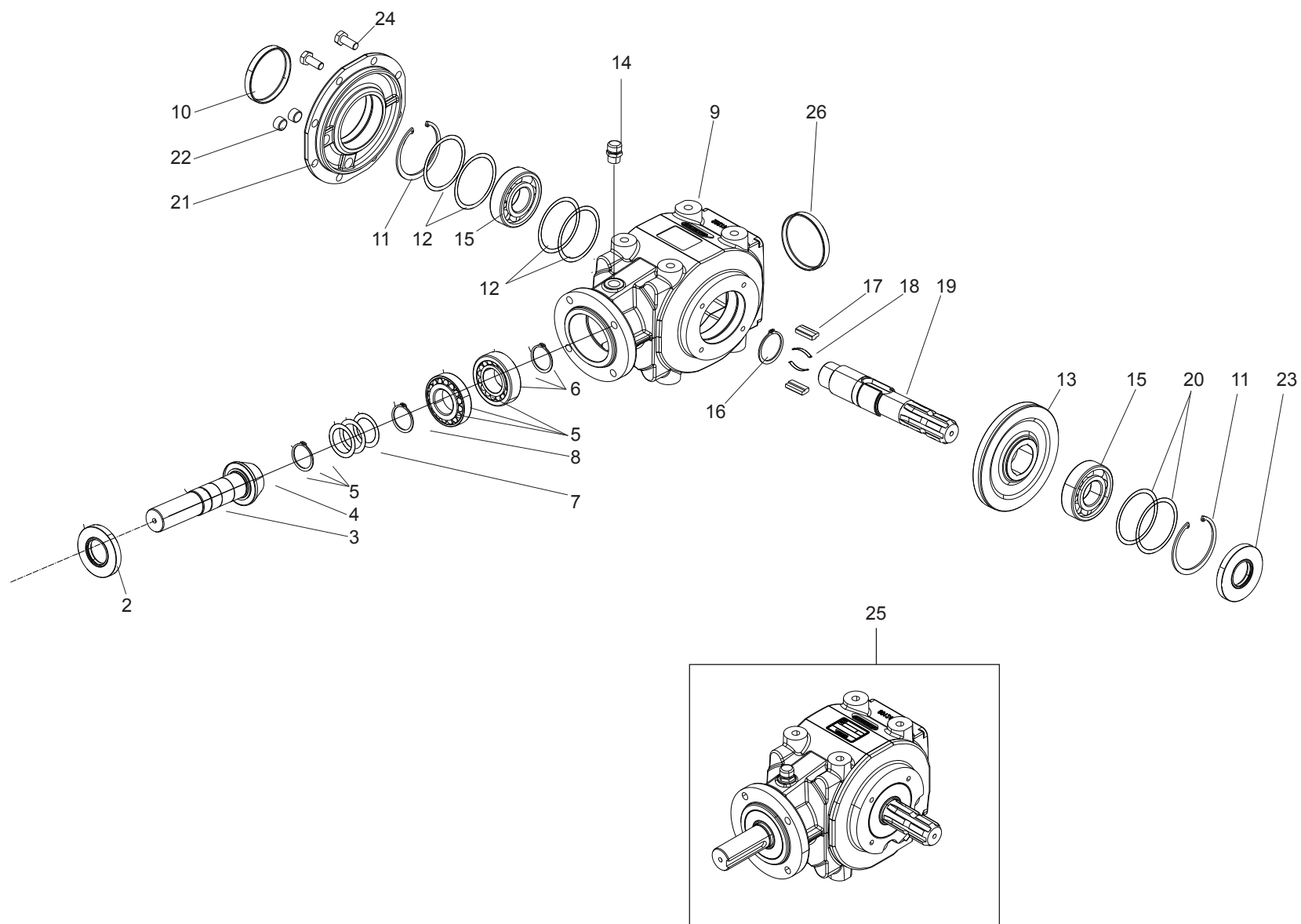

MOLTIPLICATORE 540 rpm - Comer / GEARBOX 540 rpm - Comer

TAV. 020

Pos.	Cod.	Descrizione	Description	Benennung	Description	Description
2	F03010277	ANELLO T.AS 40X 80X10 D3760NBR	OIL SEAL 40X80X10	OELABDICHTUNG 40X80X10	BOURAGE 40X80X10	JUNTA DE ACEITE 40X80X10
3	M03400021	PIGNONE	PINION	RITZEL	PIGNON	PINON
4	F02050348	ANELLO E. DI 40X1,75 U7437 C70	SEEGER RING E. 40X1,75 U7437	SEEGERING 40X 1,75 U7437 C70	SEEGER E. 40X 1,75 U7437 C70	ANILLO E. 40 X1,75 U7437 C70
5	M03400024	SPES.51.5X40.3X*	SPACER 5X40	DISTANZSTUECK 5X40	ENTRETOISE 5X40	DISTANCIADOR 5X40
7	F04050017	CUSC.D40 D80 T19,75 30208	BEARING D40 D80 T19,75 30208	LAGER D40 D80 T19,75	ROULEMENT D40 D80 T19,75 302	COJINETE D40 D80 T19,75 3020
8	F04050072	CUSC.D40 D80 T24,75 32208	BEARING D40 D80 T24,75 32208	LAGER 32208	ROULEMENT 32208	COJINETE 32208
9	M07400033	CORPO SCAT.CAMBI	GEAR BOX	WECHSELGETRIEBGEHAUSE	BOITE DE VIT.	CAJA CAMBIO
10	F03011026	TAPPO CHIUSURA D=80 X 10 GA	CAP 80X10	DECKEL 80X10	BOUCHON 80X10	CORCHO 80X10
11	F02050425	ANELLO E. DI 80X 2,5 U7437 C70	SEEGER RING D.80	SEEGERRING D.80	BAGUE SEEGER D.80	ANILLO SEEGER D.80
12	M07400032	KIT SPESSORI	REINFORCEMENTS	VERSTAERKERUNGEN	RENFORTS	RENFUERZOS
13	M03400023	CORONA CON. R.L.	RING BEVEL GEAR	KEGELRADKRANZ	COURONNE CONIQUE	CORONA CONICA
14	F03150718	TAPPO 3/8" GAS CON SFIATO	GAS BREATHER PLUG 3/8"	OELENTLUEFTERSTOPFEN	BOUCHON D'HUILE SOUPIRAIL	TAPON ACEITE
15	F04050016	CUSC.D35 D80 T22,75 30307	BEARING D35 D80 T22,75 30307	LAGER 30307	ROULEMENT 30307	COJINETE 30307
16	M03400007	SEEG.42X39,5X1,75	ELASTIC RING 42X39,5X1,75	RING 42X39,5X1,75	BAGUE ELASTIQUE 42X39,5X1,75	ANILLO UNI 42X39,5X1,75
17	M07400005	LINGUETTA	PARALLEL KEY	FEDER	CLAVETTE	LLAVE
18	M03400009	MOLLA X CHIAVET.	SPRING	FEDER	RESSORT	MUELLE
19	M03400022	ALBERO CAL. R.L.	SHAFT	ZENTRALWELLE	ARBRE	ARBOL
20	M07400032	KIT SPESSORI	REINFORCEMENTS	VERSTAERKERUNGEN	RENFORTS	RENFUERZOS
21	M03400013	COPERCHIO	COVER	DECKEL	COUVERCLE	TAPA
22	F03150719	TAPPO 3/8 GAS	CAP	DECKEL	BOUCHON	CORCHO
23	F03010278	ANEL. T.AS 40X 80X12 D3760NBR	OIL SEAL 40X80X12	OELABDICHTUNG 40X80X12	BOURAGE 40X80X12	JUNTA DE ACEITE 40X80X12
24	F01060208	VITE M10X1,5X25 U5731*8.8 ZN	BOLT M10X1,5X25	SCHRAUBE M10X1,5X25	VIS M10X1,5X25	TORNILLO M10X1,5X25
25	M50400202	SCATOLA MOLTIPL. GFN COMER	GEARBOX	WECHSELGETRIEBEGEHAUSE	BOITE DE VITESSE	CAJA CAMBIO
26	M00556298	TAPPO CIECO 100X10	COVER	DECKEL	COUVERCLE	TAPA

BONDIOLI

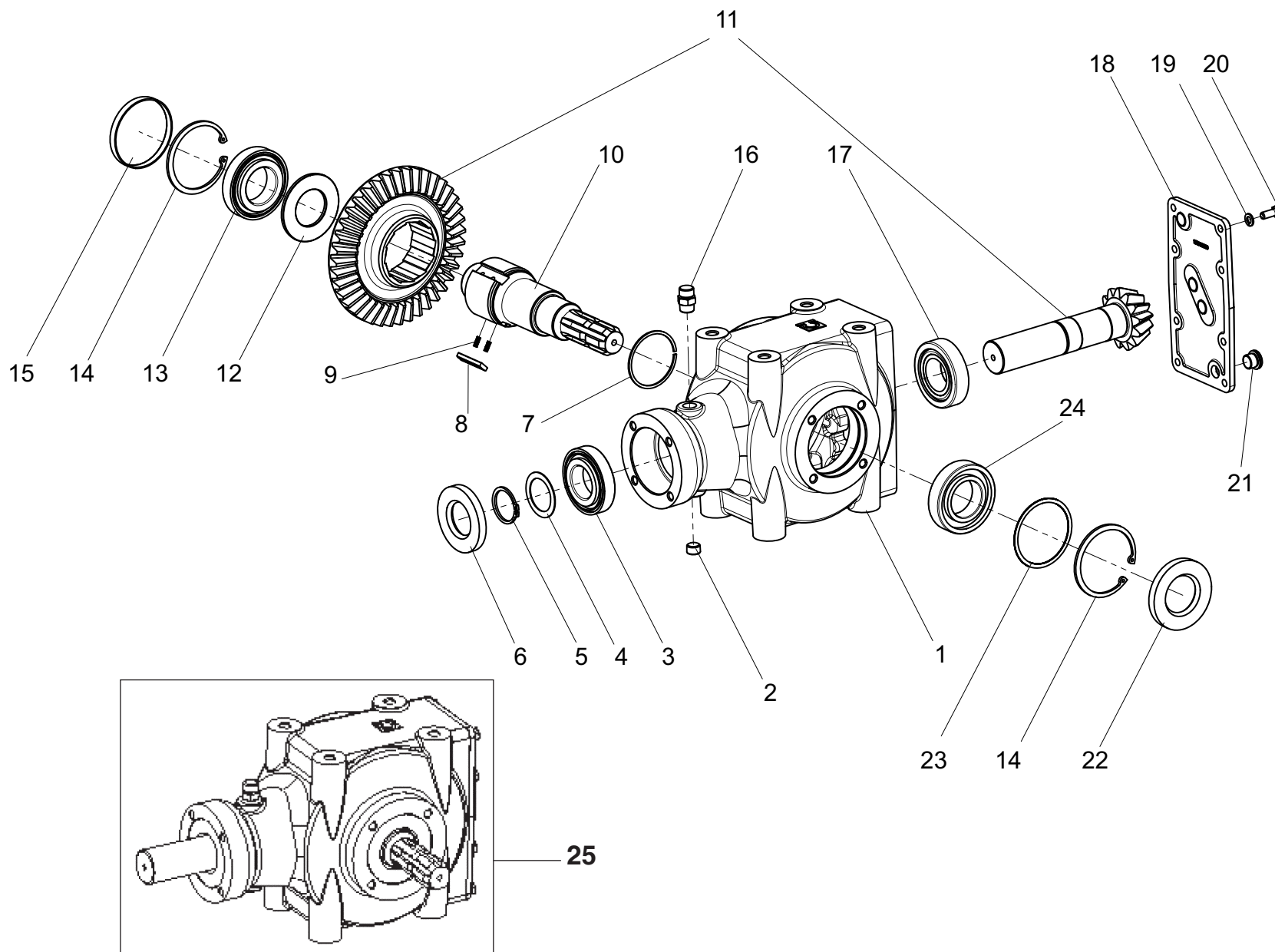

MOLTIPLICATORE 540 rpm - Bondioli / GEARBOX 540 rpm - Bondioli

TAV. 030

Pos.	Cod.	Descrizione	Description	Benennung	Description	Description
1	M50400900	SCATOLA	GEARBOX	WECHSELGETRIEBEGEHAUEUSE	BOITE DE VITESSE	CAJA CAMBIO
2	F03150719	TAPPO 3/8 GAS	CAP	DECKEL	BOUCHON	CORCHO
3	F04050017	CUSC.D40 D80 T19,75 30208	BEARING 30208	LAGER 30208	ROULEMENT 30208	COJINETE 30208
4	M50400904	ANELLI DI SPESSORAMENTO E.040	SPACER	DISTANZSTUECK	ENTRETOISE	DISTANCIADOR
5	F02050570	ANELLO E. DE 40X 2,5 U7436 C70	SPACER RING	RING	BAGUE	ANILLO
6	F03010277	ANELLO T.AS 40X 80X10 D3760NBR	OIL SEAL 40X80X10	OELABDICHTUNG 40X80X10	BOURAGE 40X80X10	JUNTA DE ACEITE 40X80X10
7	M50400909	ANELLO EL. E. 68 X1,70	LOCKRING FOR SHAFT	RING	BAGUE D'ARRET	ANILLO ELASTICO
8	M50400903	PIASTRINA	PLATE	PLATTE	PLAQUETTE	PLAQUITA
9	M50400905	MOLLA PER RUOTA LIBERA	SPRING	FEDER	RESSORT	RESSORTE
10	M50400901	ALBERO ASSE.	SHAFT	WELLE	ARBRE	ARBOL
11	M50400907	COPPIA CONICA X 50400206	BEVEL GEAR PAIR	KEGELRITZELSATZ	COUPLE CONIQUE	PAR CONICO
12	M50400902	DISTANZIALE	SPACER	DISTANZSTUECK	ENTRETOISE	DISTANCIADOR
13	F04050018	CUSC.D45 D85 T20,75 30209	BEARING D45 D85 T20,75 30209	LAGER D45 D85 T20,75 30209	ROULEMENT D45 D85 T20,75 30209	COJINETE D45 D85 T20,75 30209
14	F02050436	ANELLO E. DI 85X 3 U7437 C70	ELASTIC RING UNI 7437	RING UNI 7437	BAGUE ELASTIQUE UNI 7437	ANILLO UNI 7437
15	M50400906	TAPPO CHIUSURA 85X10	COVER D. 85X10	DECKEL D. 85X10	COUVERCLE D. 85X10	TAPA D. 85X10
16	F03150718	TAPPO 3/8" GAS CON SFIATO	OIL BREATHER PLUG	OELENTLUEFTERSTOPFEN	BOUCHON D'HUILE SOUPIRAIL	TAPON ACEITE
17	F04050072	CUSC.D40 D80 T24,75 32208	BEARING 32208	LAGER 32208	ROULEMENT 32208	COJINETE 32208
18	M50400908	KIT COPERCHIO POST.	COVER	DECKEL	COUVERCLE	TAPA
19	F01480099	ROS.G 8,4X14,4X2,7 EX.C70 ZN	GROWER WASHER D.8	SCHEIBE GROWER D.8	RONDELLE GROWER D.8	ARANDELA GROWER D.8
20	F01020436	VITE M 8X1,25X 20 U5739 8.8 ZN	SCREW M8X1,25X20 U5739 8.8 ZN	SCHRA. M8X1,25X20 U5739 8.8 ZN	VIS M8X1,25X20 U5739 8.8 ZN	TORN. M8X1,25X20 U5739 8.8 ZN
21	M29100112	TAPPO SCARICO OLIO	OIL OUTLET PLUG	OELABLASSPFROPFEN	BOUCHON DE VIDANGE HUILE	TAPON DESCARGADO ACEITE
22	F03010290	ANELLO T.AS 45X 85X10 D3760NBR	OIL SEAL 45X85X10	OELABDICHTUNG 45X85X10	PARE-HUILE 45X85X10	PARA-ACEITE 45X85X10
23	M58100127	340I08500 KIT SPES.BONDIOLI	REINFORCEMENTS FOR 58100101	VERSTAERKERUNGEN II X 58100101	RENFORTS POUR 58100101	RENFUERZOS PARA 58100101
24	F04010185	CUSC.D45 D85 B19 6209	BEARING D45 D85 6209	LAGER D45 D85 6209	ROULEMENT D45 D85 6209	COJINETE D45 D85 6209
25	M50400206	SCATOLA MOLTIPL. GFN BONDIOLI*	COMPLETE GEARBOX	WECHSELGETRIEBE KOMPL.	BOITE DE VITESSE COMPL.	CAJA CAMBIO COMPLETA

* = Versione COMER/ COMER version
 ** = Versione BONDIOLI / BONDIOLI version

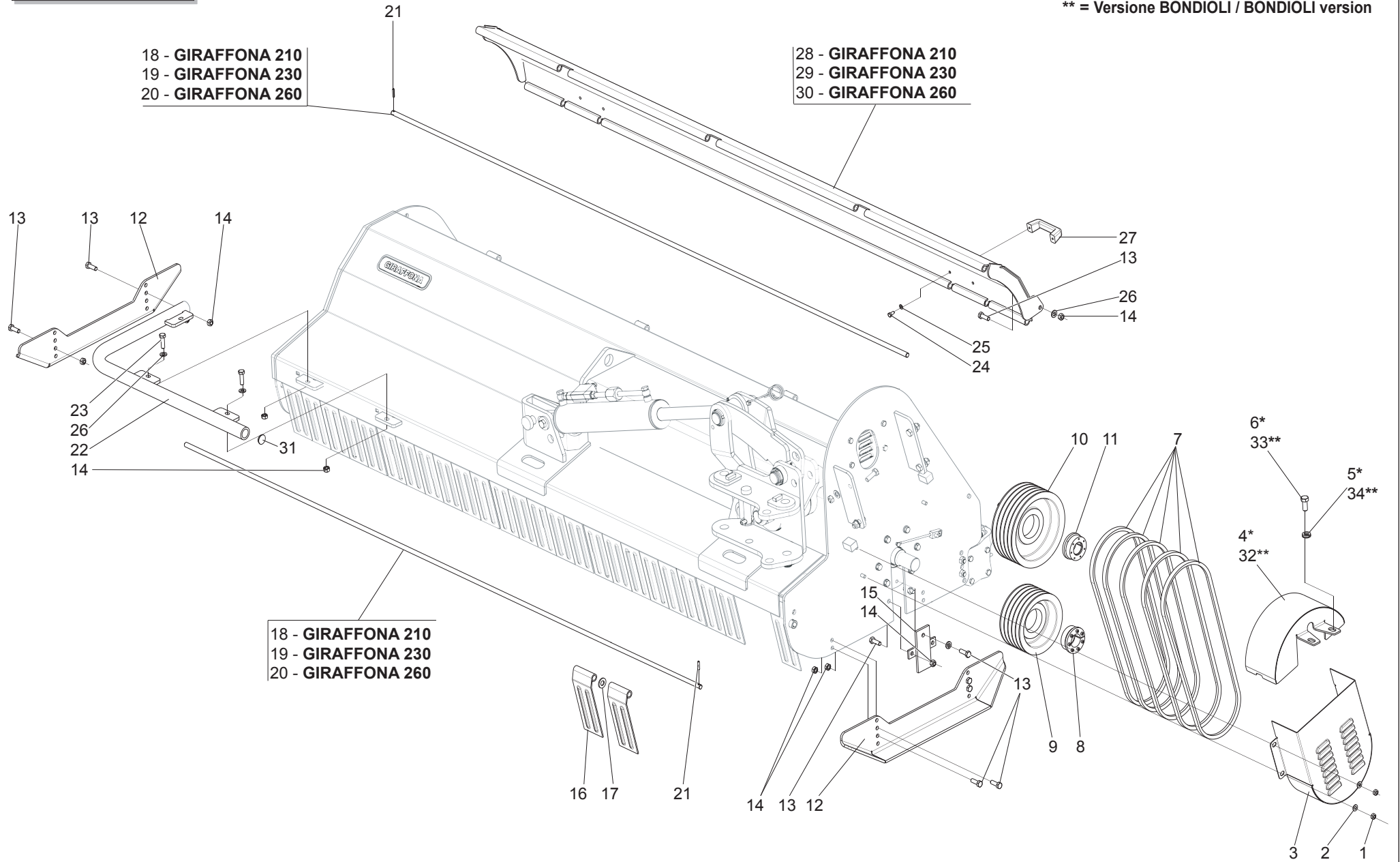

TRASMISSIONE / TRANSMISSION

TAV. 040

Pos.	Cod.	Descrizione	Description	Benennung	Description	Description
1	F01220034	DADO M10X1,25 D980 8 ZN	NUT M10X1,25 D980 8 ZB	MUTT.M10X1,25 D980 8 ZB	ECRO.M10X1,25 D980 8 ZB	TUER.M10X1,25 D980 8 ZB
2	F01410064	ROS.M10 10,5X 20X 2 U6592 ZN	WASHER M10 10,5X20X2 U6592 ZN	SCHEIBE M10 10,5X20X2 U6592 ZN	RONDELL.M10 10,5X20X2 U6592 ZN	ARAND. M10 10,5X20X2 U6592 ZN
3	M50400302	CARTER	CARTER	GEHAEUSE	CARTER	CARTER
4	M50400575	CARTER PROTEZIONE TRASMI	CARTER	GEHAEUSE	CARTER	CARTER
5	F01480145	ROS.G 17X29 X 5 EX.C70 ZN	GROWER WASHER 17X29	SCHEIBE GROWER 17X29	ROS.G 17X29 X 5 EX.C70 ZN	ARANDELA GROWER 17X29
6	F01010337	VITE M16X1,5X 35 U5740 8.8 ZN	BOLT M 16	SCHRAUBE M 16	VIS M 16	TORNILLO M 16
7	F06010112	CINGHIA SPB SV. 1600	BELT SPB 1600	SCHAUBE SPB 1600	COURROIE SPB 1600	CORREA SPB 1600
8	F06060039	CALETTATORE AUTOCENTR.45X80	SELF LOCKING KEYNG	SELBSTPERR.VERKEILEN	EMBOITAGE AUOBL.	ENSAMBLADURA AUTOBL.
9	T40005128	PULEGGIA D=200 5V	PULLEY	SCHEIBE	POULIE	ROLDANA
10	T40005120	PULEGGIA D=250 5V	PULLEY	SCHEIBE	POULIE	ROLDANA
11	F06060038	CALETTATORE AUTOCENTR.40X80	SELF LOCKING KEYNG 40X80	SELBSTPERR.VERKEILEN 40X80	EMBOITAGE AUOBL. 40X80	ENSAMBLADURA AUTOBL. 40X80
12	M31400532	SLITTA TORNADO	SKID	GLEITKUFE	GLISSIERE	TRINEO
13	F01010288	VITE M12X1,25X35 U5740 8.8 ZN	SCREW M12X1,25X35 U5740 8.8 ZN	SCHR.M12X1,25X35 U5740 8.8 ZN	VIS M12X1,25X35 U5740 8.8 ZN	TORN.M12X1,25X35 U5740 8.8 ZN
14	F01220047	DADO M12X1,25 D980 8 ZN	NUT M12X1,25 D980 8 ZN	MUTTER M12X1,25 D980 8 ZN	ECROU M12X1,25 D980 8 ZN	TUERCA M12X1,25 D980 8 ZN
15	M03400949	PIATTO CHIUSURA ASOLA	PROTECTION	SCHUTZ	PROTECTION	PROTECCION
16	M31400550	BANDELLA PROTEZIONE L=93	PROTECTION BAR	BANDE PROTECTION	SCHUTZWORNE	PROTECTION ALETA PROTECCION
17	F01410100	ROS.M16 17X 30X 3 U6592 ZN	WASHER M16 17X30X3 U6592 ZN	SCHEIBE M16 17X30X3 U6592 ZN	RONDELLE M16 17X30X3 U6592 ZN	ARANDELA M16 17X30X3 U6592 ZN
18	T24215085	ASTA BANDELLE	PROTECTION FLAP BAR	TURBAND STANGE	TIGE PALETTE PROTECTION	VARILLA BANDA
19	M03422936	PERNO BANDELLE D=15 L=2302	PROTECTION FLAP BAR	TURBAND STANGE	TIGE PALETTE PROTECTION	VARILLA BANDA
20	M03425936	PERNO BANDELLE D=15 L=2606	PROTECTION FLAP BAR	TURBAND STANGE	TIGE PALETTE PROTECTION	VARILLA BANDA
21	F02100114	SPINA E.P. 6X 30 U6873 C70 BR	ELASTIC PIN 6X30	SPANNHUELSE 6X30	GOUJON ELASTIQUE 6X30	ESPINA ELASTICA 6X30
22	M50400588	PROTEZIONE ANTERIORE	FRONT PROTECTION	VORDERER SCHUTZ	PROTECTION AVANT	PROTECCION DELANTERA
23	F01010291	VITE M12X1,25X40 U5740 8.8 ZN	SCREW M12X1,25X40 U5740 8.8 ZN	SCHR.M12X1,25X40 U5740 8.8 ZN	VIS M12X1,25X40 U5740 8.8 ZN	TORN. M12X1,25X40 U5740 8.8 ZN
24	F01020432	VITE M 8X1,25X16 U5739 8.8 ZN	BOLT M 8X16	SCHRAUBE M 8X16	VIS M 8X16	TORNILLO M 8X16
25	F01410051	ROS.M8 8,4X 17X1,6 U6592 ZN	WASHER M8 8,4X17X1,6 U6592 ZN	SCHEIBE M8 8,4X17X1,6 U6592 ZN	RONDEL. M8 8,4X17X1,6 U6592 ZN	ARANDELA M8 8,4X17X1,6 U6592ZN
26	F01410076	ROS.M12 13X 24X2,5 U6592 ZN	WASHER D12 U6592 ZN	SCHEIBE D12 U6592 ZN	RONDELLE D12 U6592 ZN	ARANDELA D12 U6592 ZN
27	F05150112	MANIGLIA INTERAS. 117 FORO 8MM	HANDLE	HANDGRIFF	POIGNEE	MANILLA
28	M50421702	COFANO POST. GFN-TIGRE 210	REARE BONNET GFN-TIGRE 210	HINTERE HAUDE GFN-TIGRE 210	CAPOT POSTERIEURE GFN-TIGRE 21	COFRE POSTERIOR GFN-TIGRE 210
29	M50423702	COFANO POST. GFN-TIGRE 230	REARE BONNET GFN-TIGRE 230	HINTERE HAUDE GFN-TIGRE 230	CAPOT POSTERIEURE GFN-TIGRE230	COFRE POSTERIOR GFN-TIGRE 230
30	M50425702	COFANO POST. GFN-TIGRE 250	REARE BONNET GFN-TIGRE 260	HINTERE HAUDE GFN-TIGRE 260	CAPOT POSTERIEURE GFN-TIGRE260	COFRE POSTERIOR GFN-TIGRE 260
31	F05100019	TAPPO AD ALETTA D. 34 PLT	PLUG D.34	VERSCHLUSSPFRPFEN D.34	BOUCHON FERMETURE D.34	TAPON CLAUSURA D.34
32	M50400709	CARTER PROT. TRASM.	CARTER	GEHAEUSE	CARTER	CARTER
33	F01020539	VITE M14X2X25 U5739 8.8 ZN	SCREW M14X2X25 U5739 8.8 ZN	SCHRAUBE M14X2X25 U5739 8.8 ZN	VIS M14X2X25 U5739 8.8 ZN	TORNILLO M14X2X25 U5739 8.8 ZN
34	F01480134	ROS.G 15X26,5X4,5 EX.C70 ZN	GROWER 15X26,5X4,5 EX.C70 ZN	SCHEIBE GROWER 15X26,5X4,5	RONDELLE GROWER 15X26,5X4,5	ARANDELA GROWER 15X26,5X4,5

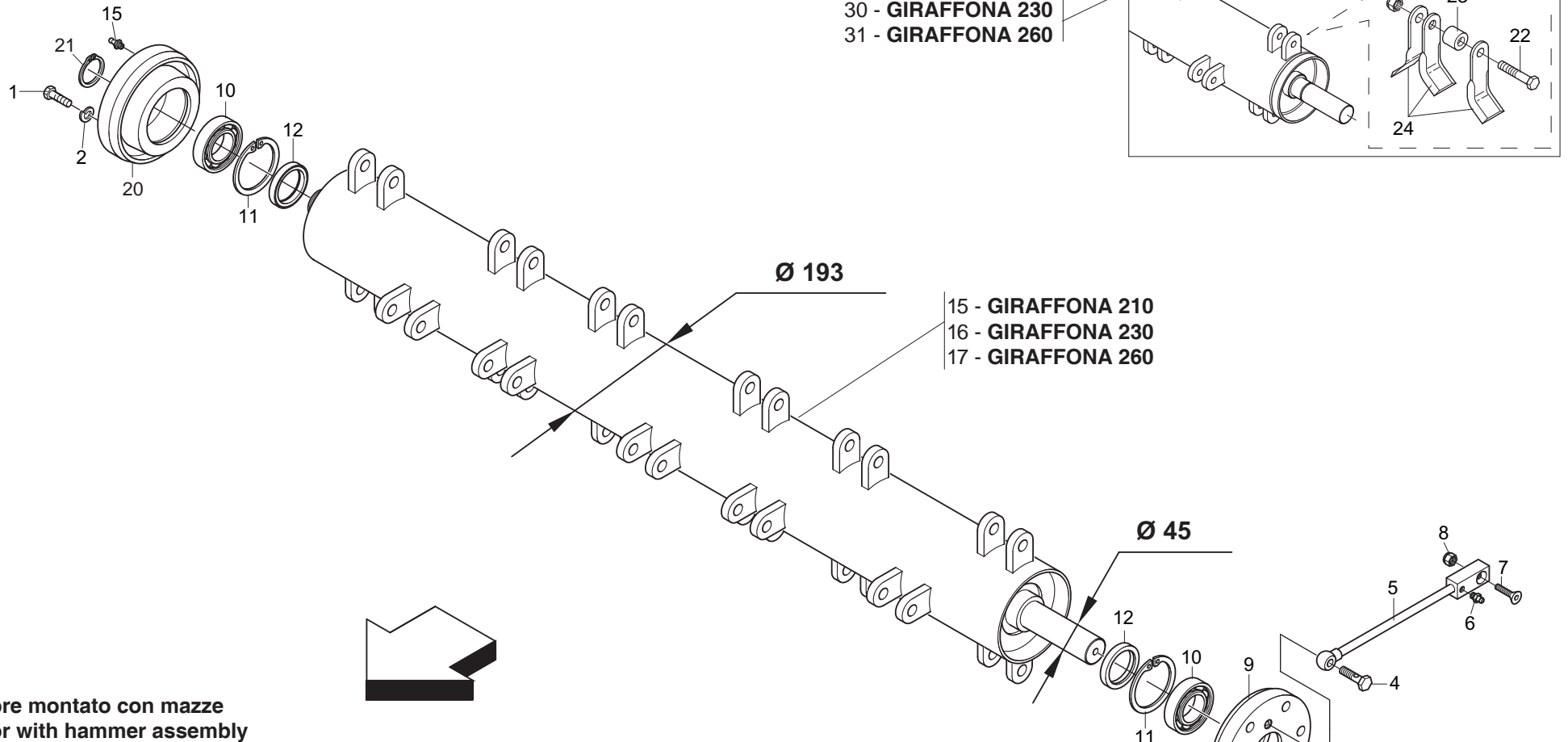

- 29 - GIRAFFONA 210
- 30 - GIRAFFONA 230
- 31 - GIRAFFONA 260

- 15 - GIRAFFONA 210
- 16 - GIRAFFONA 230
- 17 - GIRAFFONA 260

- 36 - GIRAFFONA 210
- 37 - GIRAFFONA 230
- 38 - GIRAFFONA 260

Rotore montato con mazze
Rotor with hammer assembly

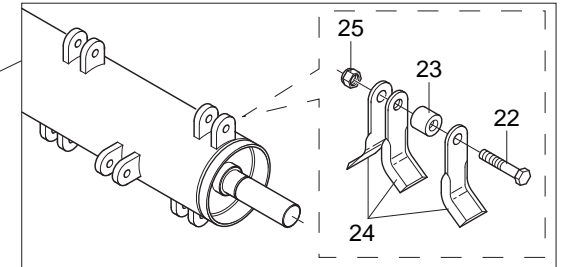
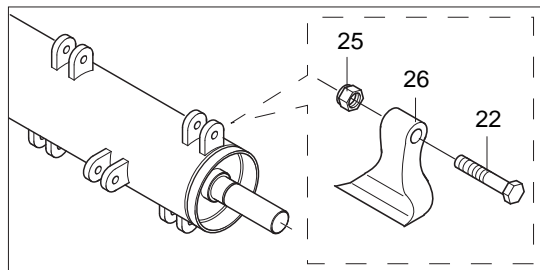

ROTORE / ROTOR

TAV. 050

Pos.	Cod.	Descrizione	Description	Benennung	Description	Description
1	F01010288	VITE M12X1,25X35 U5740 8.8 ZN	SCREW M12X1,25X35 U5740 8.8 ZB	SCHR.M12X1,25X35 U5740 8.8 ZB	VIS M12X1,25X35 U5740 8.8 ZB	TORN.M12X1,25X35 U5740 8.8 ZB
2	F01480123	ROS.G 12,5X22,9X 4 EX.C70 ZN	WASHER M12 ZGP EXTRA P.	UNTERLEGSCHEIBE M12 ZGP EXTRA	RONDELLE M12 ZGP EXTRA P.	ARANDELA M12 ZGP EXTRA P.
3	F03010313	ANELLO T.AS 55X 80X10 D3760NBR	OIL SEAL 55X80X10	OELABDICHTUNG 55X80X10	PARE-HUILE 55X80X10	PARA-ACEITE 55X80X10
4	T24004003	VITE FORATA PER INGRASSAGGIO	BOLT	SCHRAUBE	VIS	TORNILLO
5	T24004000	ASSIEME INGRASSATORE	GREASE NIPPLE	SCHMIERNIPPEL	GRAISSEUR	ENGRASADOR
6	F01100011	INGRAS.A SFERA M6X1 DRITTO A	SPHERE NIPPLE M6X1/A	KUGELFETTBSCHSE M6X1/A	GRAISSEUR A BILLES M6X1/A	ENGRAS. DE ESFERAS M6X1/A
7	F01030058	VITE M 8X1,25X30 U5933 10.9 ZD	SCREW M8X1,25X30 U5933 10,9 ZB	SCHRAUBE M8X1,25X30 U5933 10,9	VIS M8 X1,25 X30 U5933 10,9 ZB	TORNILLO M8X1,25X30 U5933 10,9
8	F01220022	DADO M 8X1,25 D980 8 ZN	SELF LOCKING NUT M8X1,25 980V	SELBSTSP.MUTT. M8X1,25 980-V	ECROU AUTOBL. M8X1,25 980-V	DADO AUTOBL. M8X1,25 980-V
9	M03400456	SUPPORTO ROTORE SX	ROTOR SUPPORT	ROTORHALTER	SUPPORT ROTOR	SOPORTE ROTOR
10	F04010016	CUSC.D55 D100 B25 2211 ETN9	BEARING D55 D100 B25	LAGER D55 D100 B25	ROULEMENT D55 D100 B25	COJINETE D55 D100 B25
11	F02050471	ANELLO E. DI100X 3 U7437 C70	SEEGER RING D.100	SEEGERRING D.100	BAGUE SEEGER D.100	ANILLO SEEGER D.100
12	F03010218	ANELLO T.A. 65X100X10 D3760NBR	RING T.A. 65X100X10 D3760 NBR	SCHUTZRING 65X100X10 D3760 NBR	BAGUE 65X100X10 D3760 NBR	ANILLO 65X100X10 D3760 NBR
15	M34421420	ROTORE TIGRE 210	ROTOR TIGRE 210	ROTOR TIGRE 210	ROTOR TIGRE 210	ROTOR TIGRE 210
16	M34423420	ROTORE TIGRE 230	ROTOR TIGRE 230	ROTOR TIGRE 230	ROTOR TIGRE 230	ROTOR TIGRE 230
17	M34425420	ROTORE TIGRE 250	ROTOR TIGRE 250	ROTOR TIGRE 250	ROTOR TIGRE 250	ROTOR TIGRE 250
20	M03400455	SUPPORTO ROTORE DX	ROTOR SUPPORT	ROTORHALTER	SUPPORT ROTOR	SOPORTE ROTOR
21	F02050215	ANELLO E. DE 55X 2 U7435 C70	SEEGER RING D.55	SEEGERRING D.55	BAGUE SEEGER D.55	ANILLO D.55
22	F20110092	VIT. M20X1.5X116 SPEC. BR.8.8	BOLT M20X1.5X116 SPEC. BR.8.8	BOZEN M20X1.5X116 SPEC. BR.8.8	VIS M20X1.5X116 SPEC. BR.8.9	TORNILLO AUTOBL. M20X1.5X116
23	M03400407	DISTANZIALE D=30 D=20 L=28 ZN	BUSHING	BUECHSE	BOUCLE	ARANDELA
24	M03400406	COLTELLO 15 A Y	BLADE "Y" 15	MESSER "Y" 15	COUTEAU "Y" 15	CUCHILLO "Y" 15
25	F01230258	DADO M20X 1,5 D985 6S ZN	SELF LOCKING NUT M20X1,5	SELBSTSPERR.MUTTER M20X1,5	ECROU AUTOBL. M20X1,5	DADO AUTOBL. M20X1,5
26	M03400410	MAZZA 14	HAMMER 14	SCHLEGEL 14	MARTEAUX 14	MARTILLO 14
29	M3442142002	COMP. R.COLT. TIGRE210 NO SUP.	BLADES HOLDER ROTOR TIGRE 210	MESSERHALTERROTOR TIGRE 210	ROTOR PORTE COUTEAUX TIGRE 210	ROTOR PORTA DIENTES TIGRE 210
30	M3442342002	COMP. R.COLT. TG230 BS220-SUP.	BLADES HOLDER ROTOR TIGRE 230	MESSERHALTERROTOR TIGRE 230	ROTOR PORTE COUTEAUX TIGRE 230	ROTOR PORTA DIENTES TIGRE 230
31	M3442542002	COMP. R.COLT. TIGRE250 NO SUP.	BLADES HOLDER ROTOR TIGRE 250	MESSERHALTERROTOR TIGRE 250	ROTOR PORTE COUTEAUX TIGRE 250	ROTOR PORTA DIENTES TIGRE 250
36	M3442142001	COMP. R.MAZZE TIGRE210 NO SUP.	HAMMERS HOLDER ROTOR TIGRE 210	SCHLEGELHALTERROTOR TIGRE 210	ROTOR PORTE MARTEAUX TIGRE 210	ROTOR PORTA MARTILL.TIGRE 210
37	M3442342001	COMP. R.MAZZE TG230 BS220-SUP.	HAMMERS HOLDER ROTOR TIGRE 230	SCHLEGELHALTERROTOR TIGRE 230	ROTOR PORTE MARTEAUX TIGRE 230	ROTOR PORTA MARTILL.TIGRE 230
38	M3442542001	COMP. R.MAZZE TIGRE250 NO SUP.	HAMMERS HOLDER ROTOR TIGRE 250	SCHLEGELHALTERROTOR TIGRE 250	ROTOR PORTE MARTEAUX TIGRE 250	ROTOR PORTA MARTILL.TIGRE 250

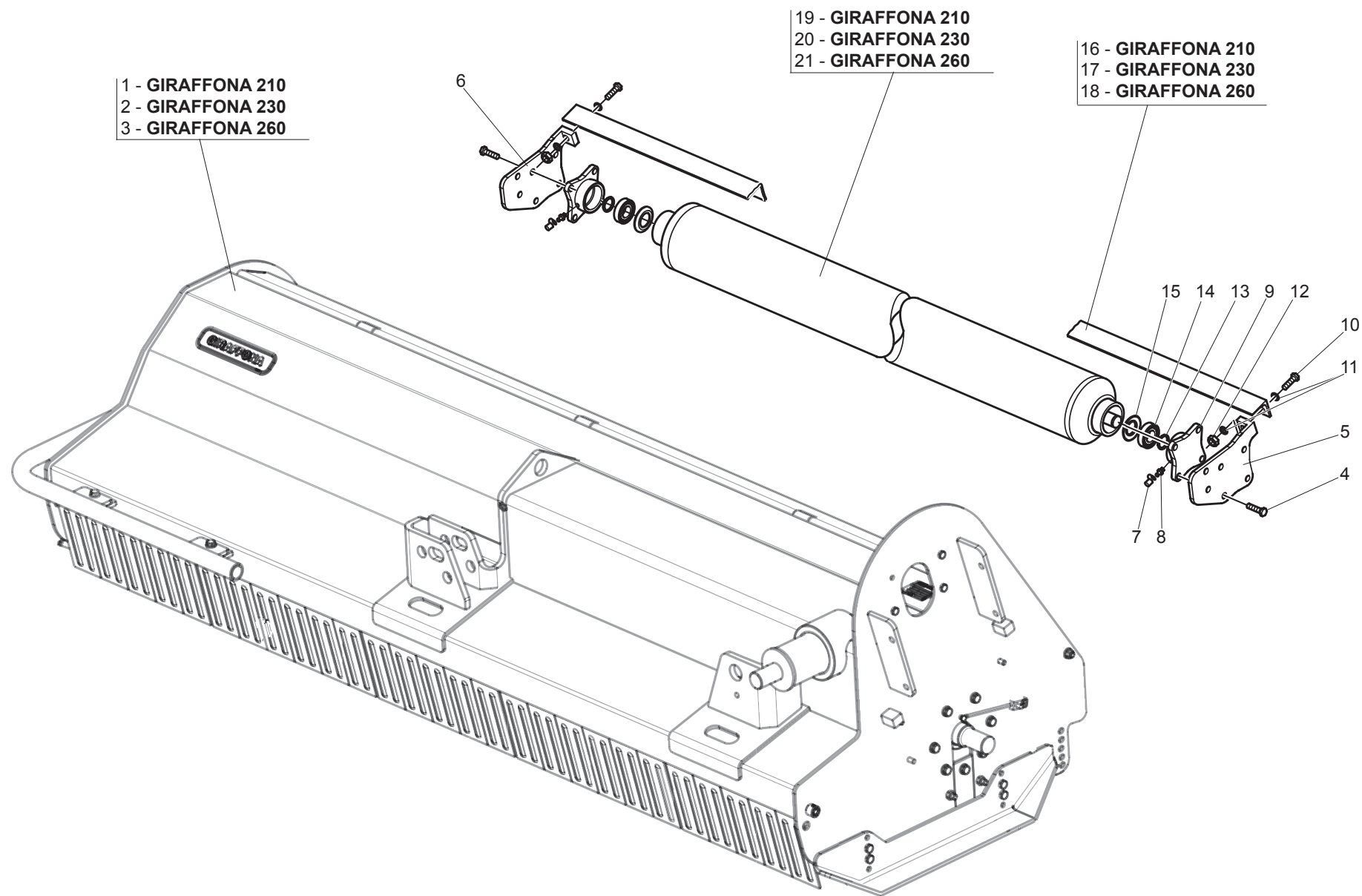

RULLO / ROLLER

TAV. 060

Pos.	Cod.	Descrizione	Description	Benennung	Description	Description
1	M50421501	COMP. TELAIO GIRAFFONA 210	COMPLETE FRAME GFHD 210	KOMPL.RAHMEN GFHD 210	CHASSIS COMPL. GFHD 210	TELAR COMPL. GFHD 210
2	M50423501	COMP. TELAIO GIRAFFONA 230	COMPLETE FRAME GFHD 230	KOMPL.RAHMEN GFHD 230	CHASSIS COMPL. GFHD 230	TELAR COMPL. GFHD 230
3	M50425501	COMP. TELAIO GIRAFFONA 260	COMPLETE FRAME GFHD 260	KOMPL.RAHMEN GFHD 260	CHASSIS COMPL. GFHD 260	TELAR COMPL. GFHD 260
4	F01010250	VITE M10X1,25X30 U5740 8.8 ZN	BOLT M10X1,25X30 U5740 8.8 ZB	SCHR.M10X1,25X30 U5740 8.8 ZB	VIS M10X1,25X30 U5740 8.8 ZB	TORN.M10X1,25X30 U5740 8.8 ZB
5	M22400615	STAFFA RULLO SX	LEFT ROLLER SUPPORT	SCHUTZHOLM WALZE LINKS	SUPPORT ROULEAU GAUCHE	SOPORTE RODILLO IZQ.
6	M22400614	STAFFA RULLO DX	RIGHT ROLLER SUPPORT	SCHUTZHOLM WALZE RECHTS	SUPPORT ROULEAU DROITE	SOPORTE RODILLO DER.
7	F05100193	CAPPUCCIO 5,95X19,05 GIALLO	CAP	DECKEL	BOUCHON	CORCHO
8	F01100011	INGRAS.A SFERA M6X1 DRITTO A	GREASE NIPPLE M6X1 7663-A ZN	SCHMIERBUECHE M6X1 7663-A ZN	GRAISS. A BILLE M6X1 7663A ZN	ENGRAS. DE ESFERAS M6X1 7663-A
9	M23400439	FLANGIA SUPP. RULLO OSC. H. 42	SUPPORT FLANGE H.42	HALTER H.42	SUPPORT H.42	SOPORTE H.42
10	F01010291	VITE M12X1,25X40 U5740 8.8 ZN	SCREW M12X1,25X40 U5740 8.8 ZN	SCHR.M12X1,25X40 U5740 8.8 ZN	VIS M12X1,25X40 U5740 8.8 ZN	TORN. M12X1,25X40 U5740 8.8 ZN
11	F01410076	ROS.M12 13X 24X2,5 U6592 ZN	WASHER D12 U6592 ZN	SCHEIBE D12 U6592 ZN	RONDELLE D12 U6592 ZN	ARANDELA D12 U6592 ZN
12	F01220047	DADO M12X1,25 D980 8 ZN	NUT M12X1,25 D980 8 ZN	MUTTER M12X1,25 D980 8 ZN	ECROU M12X1,25 D980 8 ZN	TUERCA M12X1,25 D980 8 ZN
13	F02050168	ANELLO E. DE 40X1,75 U7435 C70	SEEGER RING 40X1,75 U7435 C70	SEEGERRING 40X1,75 U7435 C70	BAGUE SEEGER 40X1,75 U7435 C70	ANIL. SEEGER 40X1,75 U7435 C70
14	F04010184	CUSC.D40 D80 BOMB.18 6208 2RS	BEARING D40 D80 BOMB.18 6208	LAGER D40 D80 BOMB.18 6208 2RS	ROULEMENT D40 D80 BOMB.18 6208	COJINETE D40 D80 BOMB.18 6208
15	M38100990	GUARNIZIONE ELASTICA	GASKET	DICHTUNG	JOINT	JUNTA
16	M34421601	RASCHIA FANGO L=2050	MUD SCRAPER L=2050	DECROTTOIR POUR BOUE L=2050	ABSTREIFER FUR SCHLAMM L=2050	RASCADOR PARA FANGO L=2050
17	M34423601	RASCHIA FANGO L=2192	MUD SCRAPER L=2192	DECROTTOIR POUR BOUE L=2192	ABSTREIFER FUR SCHLAMM L=2192	RASCADOR PARA FANGO L=2192
18	M34425601	RASCHIA FANGO L=2496	MUD SCRAPER L=2496	DECROTTOIR POUR BOUE L=2496	ABSTREIFER FUR SCHLAMM L=2496	RASCADOR PARA FANGO L=2496
19	M03421601	COMP.RULLO POSTERIORE D=203	ROLLER D=2030	ROULEAU D=2030	WALZE D=2030	RODILLO D=2030
20	M03422601	RULLO POSTERIORE BS 220	ROLLER BS220	ROULEAU BS220	WALZE BS220	RODILLO BS220
21	M03425601	RULLO POSTERIORE BS 250	ROLLER BS250	ROULEAU BS250	WALZE BS250	RODILLO BS250

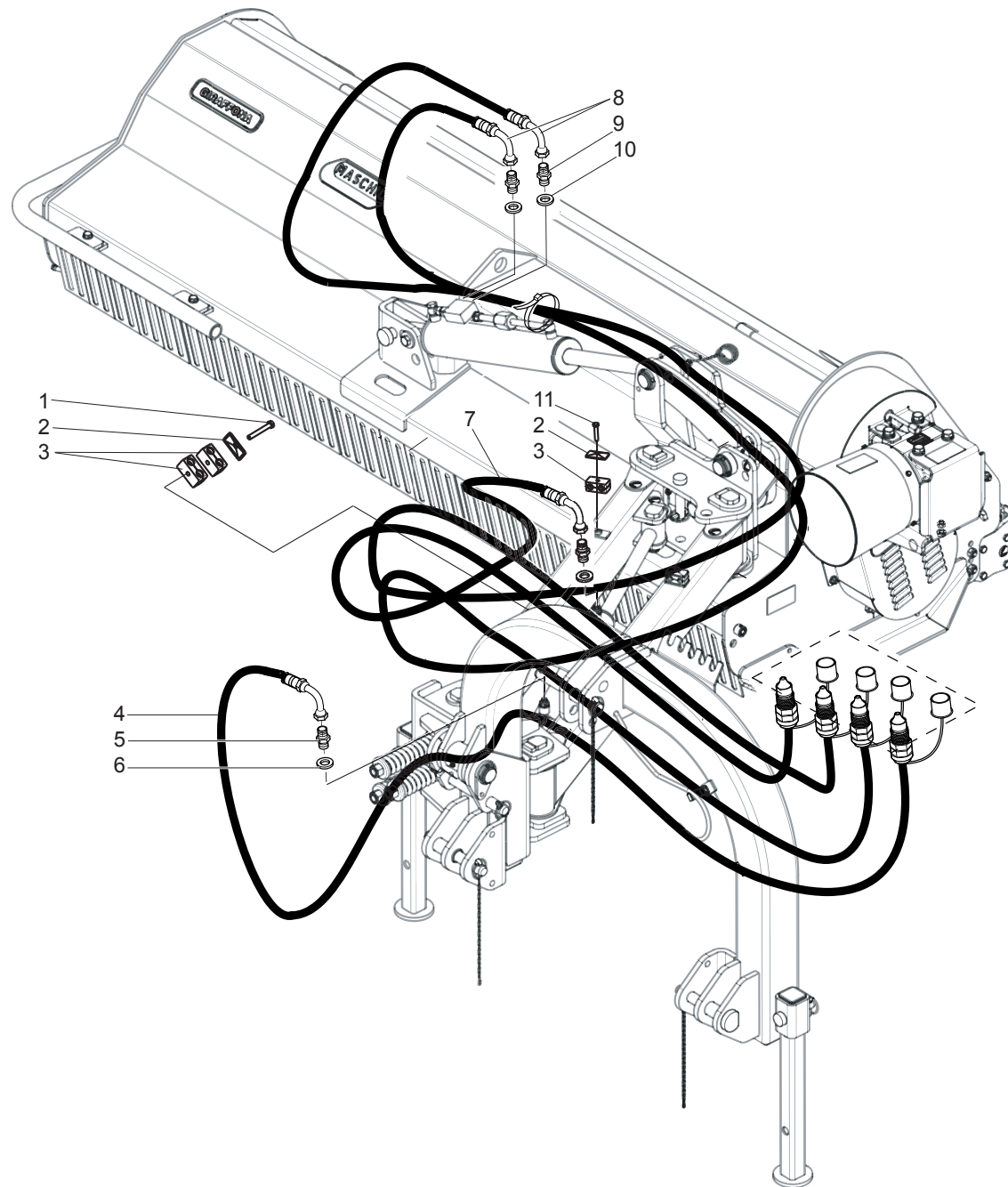

IMPIANTO IDRAULICO - HYDRAULIC PLANT

TAV. 070

Pos.	Cod.	Descrizione	Description	Benennung	Description	Description
1	F01020077	VITE M 8X1,25X60 U5737 8.8 ZN	SCREW M8X1,25X60 U5737 8.8 ZN	SCHRA. M8X1,25X60 U5737 8.8 ZN	VIS M8X1,25X60 U5737 8.8 ZN	TORN. M8X1,25X60 U5737 8.8 ZN
2	F03150993	PIATTO X COLLARE SUPERIORE ZN	PLATE	PLATTE	PLAT	PLATO
3	F03150992	COPPIA COLLARI X TUBO D.16	DOUBLE SUPPORT	DOPPELHALTER	SUPPORT DOUBLE	SOPORTE DOBLE
4	F03050233	TUBO 2SN 1/4"FD1/4 F901/4 2530	HYDRAUL. TUBE R2AT 1/4" L 2530	HYDRAUL. ROHR R2AT 1/4" L 2530	TUBE HYDRAUL. R2AT 1/4" L 2530	TUBO HYDRAUL. R2AT 1/4" L 2530
5	F03150211	NIPPLO MM CIL-CIL 1/2-1/4 ZN	NIPLE MM 1/4-1/2 ZN	NIPLE GG 1/4-1/2 ZN	NIPLE MM 1/4-1/2 ZN	NIPLE MM 1/4-1/2 ZN
6	F03151237	ROS. 21 X27X1,5 RAME -1/2"	COPPER WASHER 21X27X1,5 1/2	SCHEIBE KUPFER 21X27X1,5 1/2	RONDELLE CUIVRE 21X27X1,5 1/2	ARANDELA COBRE 21X27X1,5 1/2
7	F03050232	TUBO 2SN 1/4"FD1/4 F901/4 2900	HYDRAUL. TUBE R2AT 1/4" L 2900	HYDRAUL. ROHR R2AT 1/4" L 2900	TUBE HYDRAUL. R2AT 1/4" L 2900	TUBO HYDRAUL. R2AT 1/4" L 2900
8	F03050238	TR 2SN 1/4" FD1/4 F901/4 4900	FLEXIBLE TUBE R2AT 1/4" L.4900	FLEXILER ROHR R2AT 1/4" L.4900	TUBE FLEXIBLE R2AT 1/4" L.4900	TUBO HYDRAULICO R2AT 1/4" 4900
9	F03150211	NIPPLO MM CIL-CIL 1/2-1/4 ZN	NIPLE MM 1/4-1/2 ZN	NIPLE GG 1/4-1/2 ZN	NIPLE MM 1/4-1/2 ZN	NIPLE MM 1/4-1/2 ZN
10	F03151237	ROS. 21 X27X1,5 RAME -1/2"	COPPER WASHER 21X27X1,5 1/2	SCHEIBE KUPFER 21X27X1,5 1/2	RONDELLE CUIVRE 21X27X1,5 1/2	ARANDELA COBRE 21X27X1,5 1/2
11	F01020450	VITE M 8X1,25X40 U5739 8.8 ZN	BOLT M 8X40	SCHRAUBE M 8X40	VIS M 8X40	TORNILLO M 8X40

TAV. 080

WALTERSCHEID

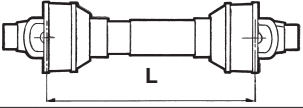
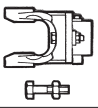
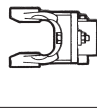
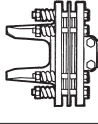
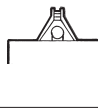
				
A F08011825 L= 1710;1 3/8"	-	X	-	GIRAFFONA

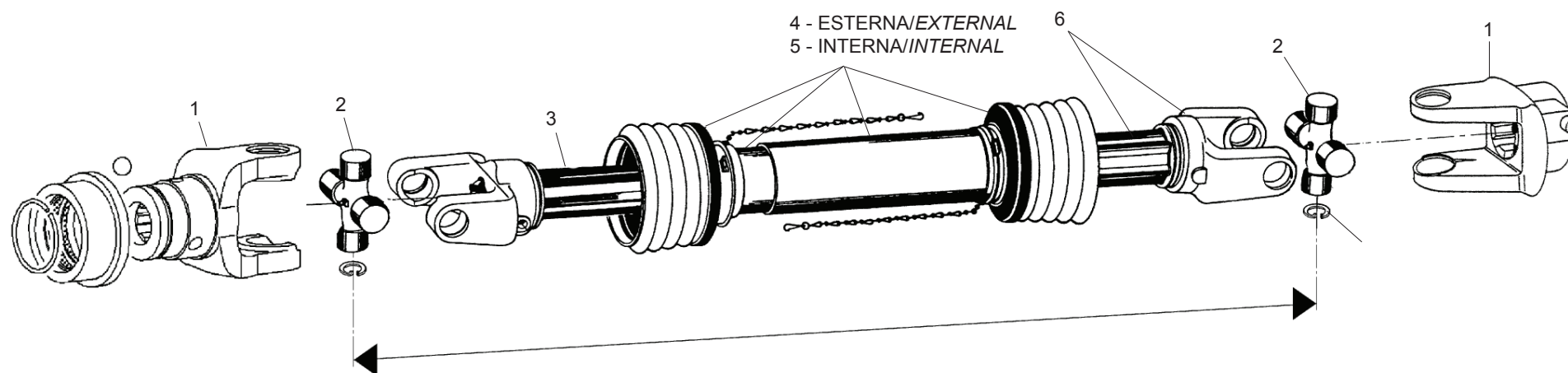

CARDANO WALTERSCHEID / WALTERSCHEID PTO SHAFT

TAV. 080

Pos.	Cod.	Descrizione	Description	Benennung	Description	Description
1	F08010459	FORCELLA COMP.PULS.-1'3/8 Z6	LINKAGE FORK-1'3/8 Z6	GABELSTUECK-1'3/8 Z6	FOURCHE ATTELAGE-1'3/8 Z6	HORQUILLAATAQUE-1'3/8 Z6
2	F08010686	CROCIERA COMPLETA	SPIDER ASSY	GELENKKREUZ KOMPL.	CROISIERE COMPL.	CRUCETA COMPLETA
3	F08012023	FOR.WS+TUB.INT.L.1560	FORK WITH INTERNAL PIPE	GABELST. + INNENROHR	FOURCHE AVEC TUBE INTERIEUR	HORQUILLA + TUBO INTERNO
4	F08012025	SEMI PROT.ES.SD25L.1500	HALF EXT. PROTECTION ASSY	AUSSEN SCHUTZ	PROTECTION EXT.	PROTECCION INTERIOR
5	F08012026	SEMI PROT.IN.SD25L.1500	HALF INT. PROTECTION ASSY	INNEN SCHUTZ	PROTECTION INT.	PROTECCION EXTERIOR
6	F08012024	FOR.WS+TUB.EST.L.1545	FORK WITH ESTERNAL PIPE	GABELST. + AUSSENROHR	FOURCHE AVEC TUBE ESTERIEUR	HORQUILLA + TUBO ESTERNO

TAV. 090

WALTERSCHEID

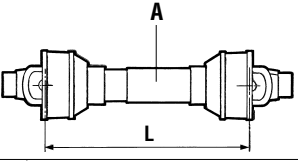
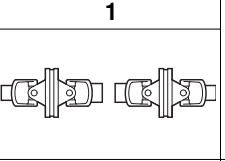
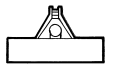
		
A F08011831 L= 1710	1	GIRAFFONA

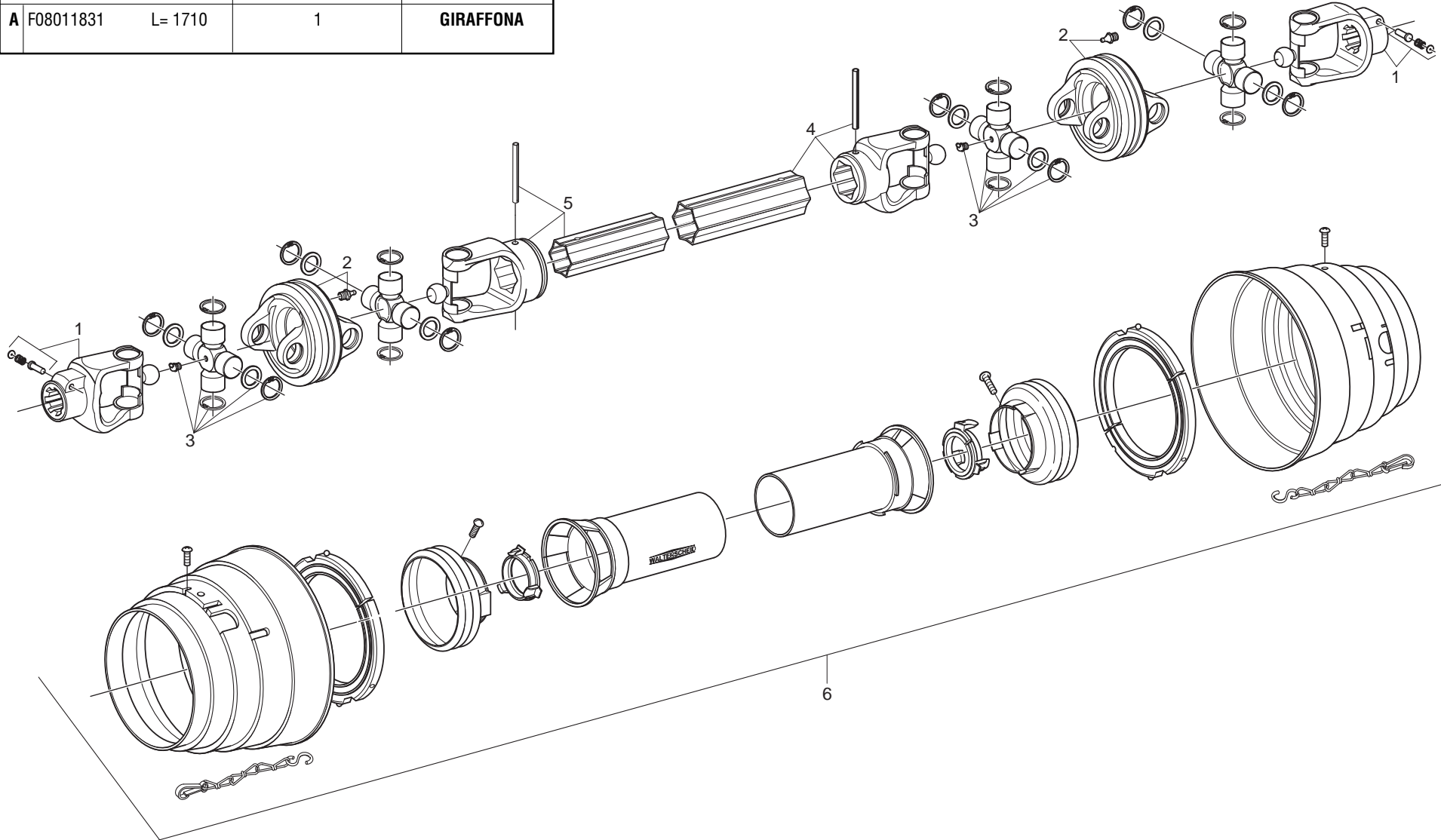

CARDANO OMOCINETICO WALTERSCHEID / WALTERSCHEID COSTANT VELOCITY PTO SHAFT

TAV. 090

Pos.	Cod.	Descrizione	Description	Benennung	Description	Description
1	F08012027	FORC.ASG WS 3/8 Z6	LINKAGE FORK	GABELSTUECK	FOURCHE ATTELAGE	HORQUILLAATAQUE
2	F08012030	FORC.DOP.XF08011831	DOUBLEYOKE+GREASENIPPLE	DOPPELGABEL+SCHMIERNIPPEL	MACHOIRE DOUBLE+GRAISSEUR	HORQUILLA DOBLA+ENGRASADOR
3	F08012029	CROC. WS XF08011831	SPIDER ASSY	GELENKKREUZ KOMPL.	CROISIERE COMPL.	CRUCETA COMPLETA
4	F08012032	FORC.+TUB. EST.WS	FORK WITH EXTERNAL PIPE	GABELST. + AUSSENROHR	FOURCHE AVEC TUBE EXTERIEUR	HORQUILLA + TUBO EXTERNO
5	F08012031	FORC.+TUB. INT.WS	FORK WITH INTERNAL PIPE	GABELST. + INNENROHR	FOURCHE AVEC TUBE INT.	HORQUILLA + TUBO INT.
6	F08012033	PROT.XF08011831*	CARDAN PROTECTION	GELENKWELLENSCHUTZ	PROTECTION CARDAN	PROTECCION CARDANICO

**USATE SEMPRE RICAMBI ORIGINALI
ALWAYS USE ORIGINAL SPARE PARTS
IMMER DIE ORIGINAL-ERSATZTEILE VERWENDEN
EMPLOYEZ TOUJOURS LES PIECES DE RECHANGE ORIGINALES
UTILIZAR SIEMPRE REPUESTOS ORIGINALES**



**Servizio Assistenza Tecnica - After Sales Service
Servizio Ricambi - Spare Parts Service
+39 049 9289888**

DEALER:



MASCHIO GASPARDO SpA
Registered Office and Production Plant
Via Marcello, 73 - 35011 Campodarsego (Padova) - Italy
Tel. +39 049 9289810
Fax +39 049 9289900
info@maschio.com
www.maschionet.com

MASCHIO GASPARDO SpA
Production Plant
Via Mussons, 7 - 33075 Morsano al Tagliamento (PN) - Italy
Tel. +39 0434 695410
Fax +39 0434 695425
info@gaspardo.it

MASCHIO DEUTSCHLAND GMBH
Äußere Nürnberger Straße 5
D - 91177 Thalmässing - Deutschland
Tel. +49 (0) 9173 79000
Fax +49 (0) 9173 790079
dialog@maschio.de
www.maschionet.de

MASCHIO-GASPARDO USA Inc
120 North Scott Park Road
Eldridge, IA 52748 - USA
Ph. +1 563 2859937
Fax +1 563 2859938
info@maschio.us

MASCHIO FRANCE Sarl
1 rue Denis Papin ZA
F - 45240 La Ferte St. Aubin
France
Tel. +33 (0) 2.38.64.12.12
Fax +33 (0) 2.38.64.66.79
info@maschio.fr

MASCHIO-GASPARDO ROMANIA S.R.L.
Strada Înfrăţirii, F.N.
315100 Chisineu-Cris (Arad) -România
Tel. +40 257 307030
Fax +40 257 307040
info@maschio.ro

000 MASCHIO-GASPARDO РУССИЯ
Улица Пушкина, 117 Б
404126 Волжский
Волгоградская область
Тел. +7 8443 515152
факс. +7 8443 515153
info@maschio.ru

MASCHIO IBERICA S.L.
MASCHIO-GASPARDO POLAND
MASCHIO-GASPARDO UCRAINA
GASPARDO-MASCHIO TURCHIA
MASCHIO-GASPARDO CINA
MASCHIO-GASPARDO INDIA
MASCHIO-GASPARDO KOREA