

MASCHIO GASPARDO S.p.A.

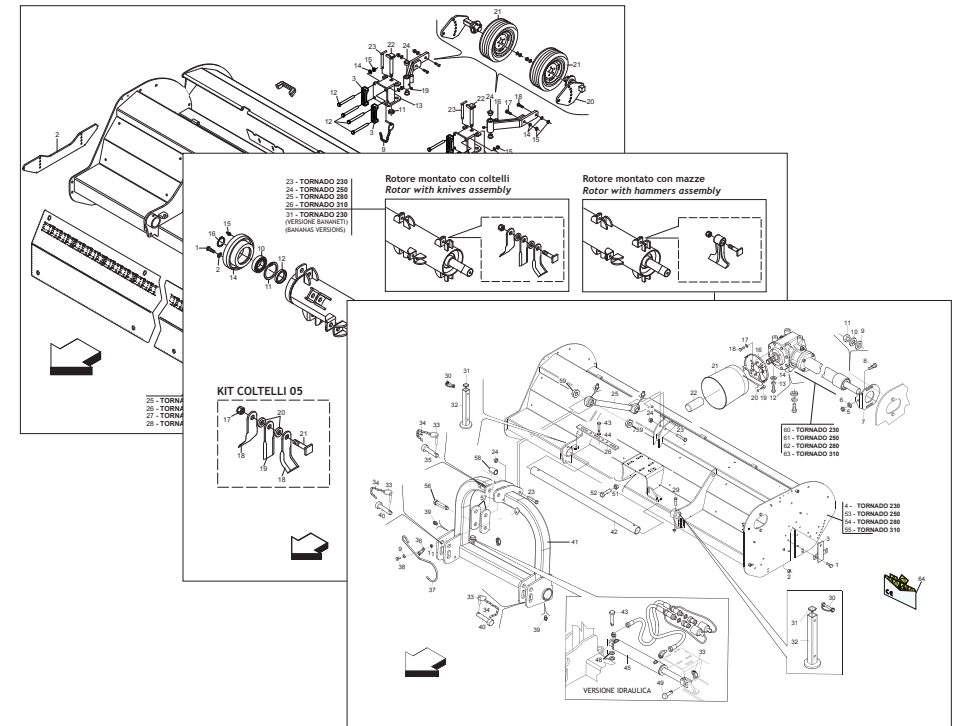

TORNADO

Cod: F07011450 2012-06

- *) Valido per Paesi UE
- *) Valid for EU member countries
- *) Valable dans les Pays UE
- *) Gilt für EU-Mitgliedsländer
- *) Válido para Países UE

- IT** PARTI DI RICAMBIO
- EN** SPARE PARTS
- DE** ERSATZTEILE
- FR** PIÈCES DÉTACHÉES
- ES** PIEZAS DE REPUESTO

PARTI DI RICAMBIO**SPARE PARTS****ERSATZTEILE****PIECES DÉTACHÉES****RESPUESTOS**

Le ordinazioni delle parti di ricambio vanno fatte presso i nostri concessionari di zona e devono essere sempre corredate dalle seguenti indicazioni:

- **Tipo, modello e numero di matricola dell'attrezzatura.** Tali dati sono stampigliati nell'apposita targhetta di cui è dotata ogni attrezzatura.

- **Numero di codice della parte richiesta** rilevabile dal catalogo ricambi.

- **Descrizione del particolare e quantità richiesta.**

- **Numero della tavola.**

- **Mezzo di trasporto.** Nel caso questa voce non sia specificata, la Ditta Costruttrice, pur dedicando a questo servizio una particolare cura, non risponde di eventuali ritardi di spedizione dovuti a cause di forza maggiore.

Le spese di trasporto si intendono sempre a carico del destinatario. La merce viaggia a rischio e pericolo del committente anche se venduta franco destino.

NOTA: Il termine **(Dx) Destro** o **(Sx) Sinistro** della macchina o di parti di essa, è inteso guardando la macchina dalla parte posteriore. Le eccezioni saranno indicate.

Orders must be transmitted through our area dealers and should always include the following indications:

- **Type, model and serial number of the machine.** *These data are punched on the data plate with which every implement is equipped.*

- **Code number of the required spare part.** *This will be found in the spare parts catalogue.*

- **Description of the part and required quantity.**

- **Table number.**

- **Means of dispatch.** *If this item is not indicated, the Manufacturer, while dedicating particular care to this service, shall not be held responsible for delays in delivery caused by cases of force majeure.*

Transport expenses shall always be at the consignee's charge. The goods travel at the purchaser's risk and peril even when sold ex destination.

NOTE: *The symbols (Dx) right and (Sx) left, concerning the machine or single parts of it, are referred, as in the figure, to a rear view of them. Exceptions will be indicated.*

Die Bestellungen müssen bei unseren Gebietshändlern aufgegeben werden. Bei der Bestellung sind stets die folgenden Angaben zu machen:

- **Typ, Modell und Serien-Nummer des Geräts.** Diese Daten stehen auf dem Typenschild, mit dem jedes Gerät versehen ist.

- **Artikel Nr. der erforderlichen Ersatzteile.** Diese stehen im Ersatzteil-Katalog.

- **Beschreibung des Ersatzteils und die erforderliche Stückzahl.**

- **Tafelnummer.**

- **Versandmittel.** Wenn dieser Punkt nicht spezifiziert wird, haftet die Herstellerfirma nicht für etwaigen Lieferverzug aufgrund höherer Gewalt, auch wenn er diesen Service besonders aufmerksam abwickelt.

Die Frachtkosten gehen dagegen immer zu Lasten des Empfängers. Die Ware reist auf Gefahr und Risiko des Auftraggebers, auch wenn frei Haus Verkauft vereinbart worden ist.

N.B.: Die Merkzeichen **(Dx) rechts** und **(Sx) links** betreffen eine rückwärtige Aussicht der Maschine oder Teile von ihr (siehe Bild). Ausnahmen werden gezeigt.

Les ordres doivent être effectués auprès de nos concessionnaires de zone en précisant les indications suivantes:

- **Type, modèle et numéro de série de la machine.** *Ces données sont gravées sur la plaque d'identification de chaque outil.*

- **Numéro de code de la pièce détachée** *indiqué sur le catalogue des pièces détachées.*

- **Description de la pièce et quantité requise.**

- **Numéro de plan.**

- **Moyen d'expédition.** *Si cette rubrique n'est pas indiquée, le Constructeur, bien que soucieux de ce service, ne répond pas des retards d'expédition pour des causes de force majeure.*

Les frais de transport sont toujours à la charge du destinataire. La marchandise voyage aux risques et périls de l'acheteur même si vendue franco de port.

N.B.: *Les références (Dx) droit et (Sx) gauche de la machine ou des parties de la même, est entendue, comme de la figure, en regardant la machine de derriere dans le sens de marche.*

Los pedidos han de efectuarse en nuestros concesionarios de zona y deben incluir siempre las siguientes indicaciones:

- **Tipo, modelo y número de matrícula del equipo.** Dichos datos están impresos en la relativa placa presente en el equipo.

- **Número de código de la parte requerida** presente en el catálogo respuestas.

- **Descripción de la pieza y cantidad requerida.**

- **Numero de ilustración.**

- **Medio de transporte.** En caso que este ítem no esté especificado, el Fabricante, aún prestando la debidas consideraciones para este aspecto, no responde por eventuales retardos de env'o debidos a causas de fuerza mayor.

Los gastos de transporte se consideran siempre a cargo del destinatario. La mercadería viaja bajo riesgo y peligro del comprador, incluso cuando se vende franco destino.

N.B.: La referencia **(Dx) derecha** o **(Sx) izquierda** de la máquina o de sus componentes, se entiende, como en la figura, mirando la máquina por la parte trasera. Se indicarán las excepciones.

INDICE

<i>N° Tavola</i>	<i>Descrizione</i>	<i>Pagina</i>
TAV. 010	ASSIEME GENERALE	6
TAV. 020	MOLTIPLICATORE	8
TAV. 030	TELAIO	10
TAV. 040	ROTORE	12
TAV. 050	SLITTE, LAM. ANTIUSURA e RUOTE STERZ. POST.	14
TAV. 060	RUOTE DI TRASPORTO	16
TAV. 070	CARDANO	18

INDEX

<i>N° Table</i>	<i>Description</i>	<i>Page</i>
TAV. 010	GENERAL ASSEMBLY	6
TAV. 020	GEARBOX	8
TAV. 030	FRAME	10
TAV. 040	ROTOR	12
TAV. 050	SKIDS, DOUBLE SKIN and REAR STEERING WHEELS	14
TAV. 060	TRANSPORT WHEELS	16
TAV. 070	CARDAN SHAFT	18

TAV. 010

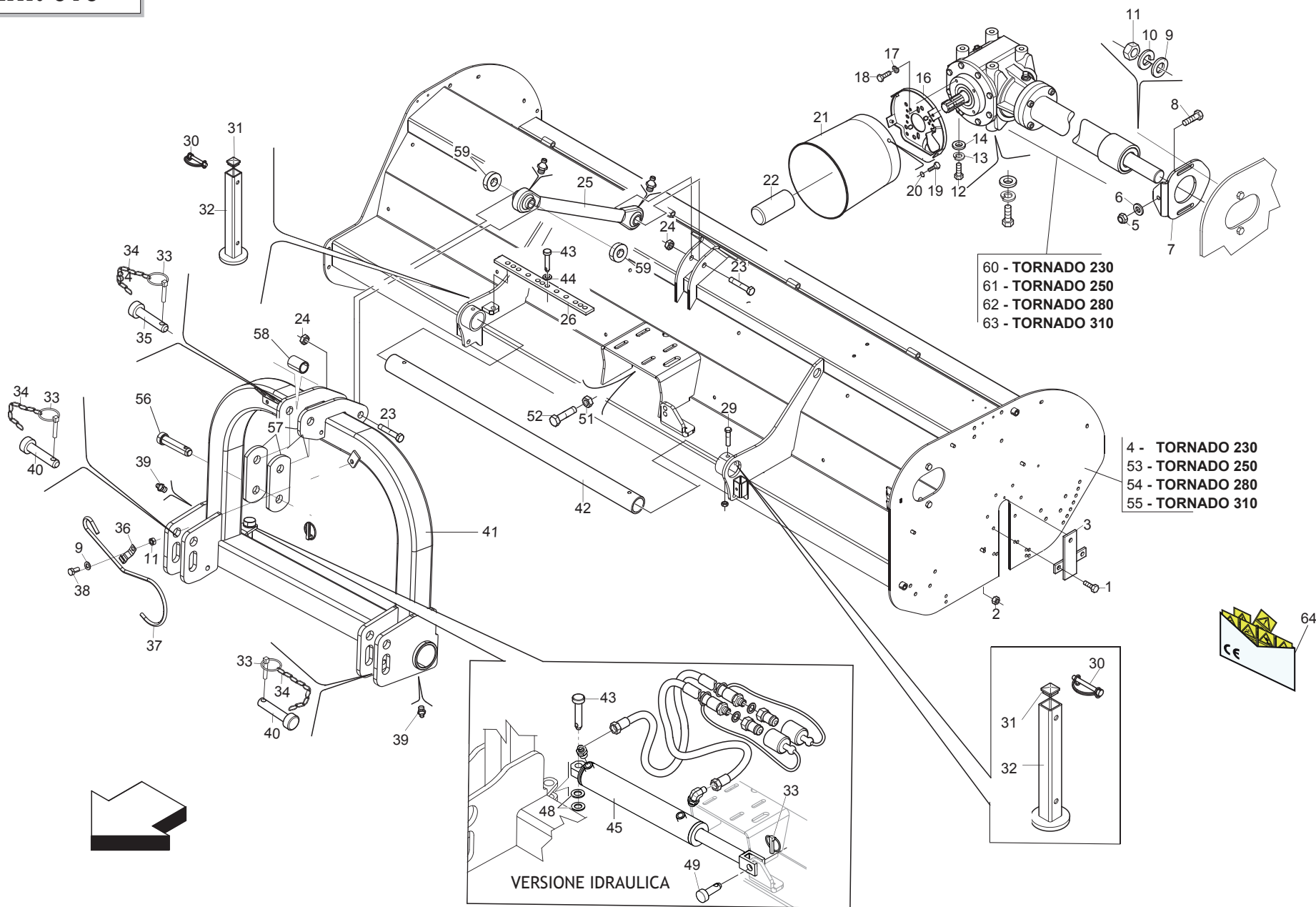

**ASSIEME GENERALE
GENERAL ASSEMBLY**

TAV. 010

Pos.	Cod.	Descrizione	Description	Benennung	Description	Descripcion
1	F01010313R	VITE M14X1,5X30	SCREW M14X1,5X30 U5740 8.8ZN	VIS M14X1,5X30 U5740 8.8ZN	SCHRAUBE M 14X1,5X30	TORNIL. M14X1,5X30 U5740 8.8ZN
2	F01220059R	DADO M14X1,5	NUT M14X1,5 D980 8ZN	ECROU M14X1,5 D980 8ZN	SELBSTSP.MUTT. M14X1,5 980-V	TUERCA M14X 1,5 D980 8 ZN
3	M314200558R	COMP.CHIUSURA ROTORE TORNADO	PLATE	PLAQUETTE	PLATTE	PLAQUITA
4	M31423540R	TELAIO TORNADO 230	FRAME TORNADO 230	CHASSIS TORNADO 230		BASTIDOR TORNADO 230
5	F01230073R	DADO M14X2	NUT M14X2 D982 8ZN	ECROU M14X2 D982 8ZN	SELBSTSP.MUTT. M14X2	TUERCA AUTOBL. M14X2 D982 8ZN
6	F01410088R	ROS.M14 15X 28X2,5	WASHER M14 15X 28X2,5	RONDELLE M14 15X 28X2,5	SCHLEIBE M14 15X28X2,5 U6592 ZB	ARA.M14 15X 28X2,5 U6592 ZB
7	M31400572R	PIATTO REGISTRO TENDICINGHIA	PLATE STRETCHER		PLATTE STRETCHER	
8	F01020550R	VITE M14X2X120	SCREW M14X2X120 U5739 8.8ZN	VIS M14X2X120 U5739 8.8ZN	SCHRAUBE M14X2X120	TORNILLO M14X2X120 U5739 8.8ZN
9	F01410076R	ROS.M1213X24X2,5	WASHER 12 13X 24X2,5	RONDELLE 12 13X 24X2,5	SCHLEIBE D12 UNI 6592 ZN	ARAND.M12 13X 24X2,5 U6592 ZN
10	F01480123R	ROS.G 12,5X22,9X 4	GROVER WASHER M12 ZGP EXTRA P.	GROVER RONDELLE M12 ZGP EXTRA	UNTERLEGSCHLEIBE M12 ZGP EXTRA	ARANDELA M12 ZGP EXTRA P.
11	F01220047R	DADO M12X1,25	NUT M12X1,25	ECROU M12X1,25 D980 8ZN	SELBSTSP.MUTTER M12X1,25 980-V	TUERCA M12X1,25 D980 8 ZN
12	F01020566R	VITE M16X2X40	SCREW M16X2X40 U5739 8.8ZN	VIS M16X2X40 U5739 8.8ZN	SCHRAUBE M16X2X40 U5739 8.8 ZN	TORNILLO M16X2X40 U5739 8.8ZN
13	F01480145R	ROS.G 17X29X5	GROWER WASHER 17X29	GROWER RONDELLE 17X29	SPRENGRING D.16	ARANDELA GROWER 17X29
14	F01410100R	ROS.M16 17X30X 3	WASHER M16 17X30X3	RONDELLE M16 17X30X3	SCHLEIBE D.16 UNI 6592 ZN	ARAND.M16 17X 30X 3 U6592 ZN
16	M37100106R	ATTACCO PROTEZIONE	PROTECTION SUPPORT	SUPPORT PROTECTION CARDAN	GELENKWELLENSCHUTZ HALTER	SOPORTE PROTECCION CARDANICO
17	F01480099R	ROS.G 8,4X14,4X2,7	GROWER WASHER D.8	GROWER RONDELLE D.8	SPRENGRING D.8	ARANDELA GROWER D.8
18	F01020432R	VITE M8X1,25X16	SCREW M8X1,25X16 U5739 8.8ZN	VIS M8X1,25X16 U5739 8.8ZN	SCHRAUBE M 8X16	TORN. M8X1,25X16 U5739 8.8ZN
19	F01020403R	VITE M6X1X16	SCREW M6X1X16 U5739 8.8ZN	VIS M6X1X16 U5739 8.8ZN	SCHRAUBE M 6X16	TORNILLO M6X1X16 U5739 8.8ZN
20	F01410037R	ROS.M6 6,4X12,5X1,6	WASHER M6 6,4X12,5X1,6	RONDELLE M6 6,4X12,5X1,6	SCHLEIBE D.6	ARAND.M6 6,4X12,5X1,6 U6592 ZN
21	M10100168R	PROTEZIONE CARDANO	CARDAN PROTECTION	PROTECTION CARDAN	GELENKWELLENSCHUTZ	PROTECCION CARDANICO
22	M38100146R	MANICOTTO PROTEZIONE PDF 1 3 8	P.T.O. PROTECTION	MANCHON PROTECTION PDF 1 3 8	ZAPFWELLENSCHUTZ P.T.O.	MANGUITO PROTECCION PDF 1 3 8
23	F01010177R	VITE M20X1,5X130	SCREW M20X1,5X130 U5738 8.8ZN	VIS M20X1,5X130 U5738 8.8ZN	SCHRAUBE M 20X1,5X130	TORNIL.M20X1,5X130 U5738 8.8ZN
24	F01220093R	DADO M20X1,5	NUT M20X1,5	ECROU M20X1,5 D980 8ZN	SELBSTSPERR.MUTTER M20X1,5	TUERCA M20X1,5 D980 8ZN
25	M24400544R	TIRANTE 3 PUNTO	3RD POINT TIE ROD		3.PUNKT ZUGSTANGE	
26	M34400516R	ASTA SPOST.MECCANICO	MECH. OFFSET BAR	BARRE DE DEPLACEMENT MECAN.	MECH.VERSCHIEBUNG STANGE	
29	F01010288R	VITE M12X1,25X35	SCREW M12X1,25X35 U5740 8.8ZN	VIS M12X1,25X35 U5740 8.8ZN	SCHRAUBE M12X1,25X35	TORNIL.M12X1,25X35 U5740 8.8ZN
30	F02200562R	SPINA SICUR.D. 8X70 ZN	SNAP PIN D.8X 70 ZN	FICHE EL. D.8X70 ZN	SCHERSTIFT D.8X 70 ZN	CLAVIJA D.8X 70 ZN
31	F05100025R	TAPPO AD ALETTE 35X35 PLT NERO	PLUG	BOUCHON FERMETURE	VERZUESSPFROPFEN	TAPONCLAUSURA
32	M56400922R	PIEDINO L=424,3	SUPPORT ASSEMBLY L=424,3	SUPPORT L=424,3	ST TZE L =424,3	SOPORTE L=424,3
33	F02200529R	SPINA SCATTO D.11 H58 ZN	SNAP PIN D.11 H58 ZN	FICHE A DETENTE D.11 H58 ZN	EINRASTSTIFT D.11 ZB	CLAVIJA DE MUELLE D.11 H58 ZN
34	M58100930R	CATENELLA L=476	ASSEMBLY CHAIN DMP L=476	CHAINE L=476	KETTE L=476	CADENA L=476
35	F20100133R	PERNO D25 L122 C43 TEST.D60 ZN	PIN D25 L122 C43 TEST.D60 ZN	GOUJON D25 L122 C43 TEST.D60ZN	BOLZEN D25 L128 ZN	PERNO D25 L122 C43 TEST.D60 ZN
36	F20120401R	FASCETTA FERMA CARDANO ZN	SHAFT HOOK SUPPORT	SUPPORT CARDAN	GELENKWELLE HACKEN HALTER	SOPORTE CARDAN
37	F20120400R	GANCIO SOSTEGNO CARDANO	SHAFT HOOK SUPPORT	SUPPORT CARDAN	GELENKWELLE - HAKEN	SOPORTE CARDAN
38	F01010281R	VITE M12X1,25X25	SCREW M12X1,25X25 U5740 8.8ZN	VIS M12X1,25X25 U5740 8.8ZN	SCHRAUBE M12X1,25X25	TORNIL.M12X1,25X25 U5740 8.8ZN
39	F01100048R	ING.M 8X1,25 7663A 9SMNPB28 Z	GREASE NIPPLE M8X1,25 U7663A	GRAISSEUR A BILLES M8X1,25	SCHMIERNIPPEL M8 X 1-25 A	ENG.M 8X1,25 7663A 9SMNPB28 Z
40	F20100074R	PERNO D28 L109 C43 SPINA 3 P.	PIN D28 L109 C43 SPINA 3 P.	GOUJON D28 L109 C43 SPINA 3 P.	VERB.BOLZEN SCHUTZHOLM	PERNO D28 L109 C43 SPINA 3 P.
41	M31400577R	CASTELLO T.P.TORNADO-TIGRE	HEADFRAME T.P.TORNADO-TIGRE		RAHMEN T.P. TORNADO 08	
42	M24415533R	ASTA SCOR.CHIARA 160 L=1467 ZN	GUIDE ROD CHIARA 160 L=1467 ZN			
43	F20100035R	PERNO D19 L90 C43 TEST.D35 ZN	PIN D19 L90 C43 TEST.D35 ZN	GOUJON D19 L90 C43 TEST.D35 ZN	BOLZEN	PERNO D19 L90 C43 TEST.D35 ZN
44	F01410124R	ROS.M20 21X 37X 3	WASHER M20 21X 37X 3	RONDELLE M20 21X 37X 3	SCHLEIBE D20 UNI 6592 ZN	ARAND.M20 21X 37X 3 U6592 ZN
45	M31430946R	MARTINETTO ID.A=60 C=300 L=830	JACK ID.A=60 C=300 L=830		SPINDEL ID.A=60 C=300 L=830	
48	F01410124R	ROS.M20 21X 37X 3	WASHER M20 21X 37X 3	RONDELLE M20 21X 37X 3	SCHLEIBE D20 UNI 6592 ZN	ARAND.M20 21X 37X 3 U6592 ZN
49	F20100034R	PERNO D19 L40 C43 TEST.D35 ZN	PIN D19 L40 C43 TEST.D35 ZN	GOUJON D19 L40 C43 TEST.D35 ZN	STIFT D=19 L=46	PERNO D19 L40 C43 TEST.D35 ZN
51	F01200268R	DADO M10X1,25	NUT M10X1,25	ECR.M10X1,25 U5588 CL8 GALV	MUTTER M10X1,25	TUERCA M10X1,25
52	F01010033R	VITE M10X1,25X80	SCREW M10X1,25X80 U5738 8.8ZN	VIS M10X1,25X80 U5738 8.8ZN	SCHRAUBE M 10X1,25X80	TORNIL.M10X1,25X80 U5738 8.8ZN
53	M31425540R	TELAIO TORNADO 250	FRAME TORNADO 250	CHASSIS TORNADO 250		BASTIDOR TORNADO 250
54	M31428540R	TELAIO TORNADO 280	FRAME TORNADO 280	CHASSIS TORNADO 280		BASTIDOR TORNADO 280
55	M31431540R	TELAIO TORNADO 310	FRAME TORNADO 310	CHASSIS TORNADO 310		BASTIDOR TORNADO 310
56	F20100063R	PERNO D25 L91 C43 TEST.D35 ZN	PIN D25 L91 C43 TEST.D35 ZN	GOUJON D25 L91 C43 TEST.D35ZN	BOLZEN GASPARDO D25 L113 C40	PERNO D25 L91 C43 TEST.D35 ZN
57	T30005107R	PIATTO ATTACCO 3 PUNTO CR	REAR SUPPORT 3RD POINT CR	BARRE CR	HINTERSTANGE 3. PUNKT CR	ASTA POSTERIOR 3 PUNTO CR
58	M68100932R	BUSSOLA	BUSHING	BOUSSOLE	BUECHSE	BRUJULA
59	M19400536R	DISTANZ.D=50 D=22,5 L=14 ZG	SPACER	ENTRETOISE	DISTANZSTUECK	DISTANC.D=50 D=22,5 L=14 ZN
60	M31423201R	MOLTIPLIC.BOND.540 L= 990	MULTIPLICATOR BOND.540 L= 990		GETRIEBELIC.BOND.540 L= 990	
61	M31425201R	MOLTIPLIC.BOND.540 L= 1115	MULTIPLICATOR BOND.540 L= 1115		GETRIEBE BOND.540 L= 1115	
62	M31428201R	MOLTIPLIC.BOND.540 L= 1240	MULTIPLICATOR BOND.540 L= 1240			
63	M31431201R	MOLTIPLIC.BOND.540 L= 1560	MULTIPLIER.BOND.540 L=1560		GETRIEBELIC.BOND.540 L= 1560	CAJA CAMBIO BOND.540 L= 1560
64	F20030241R	KIT.ET.CE TRINCIA	KIT CE LABELS MULCHERS		KIT AUFKLEBER F R MULCHGER TE	

TAV. 020

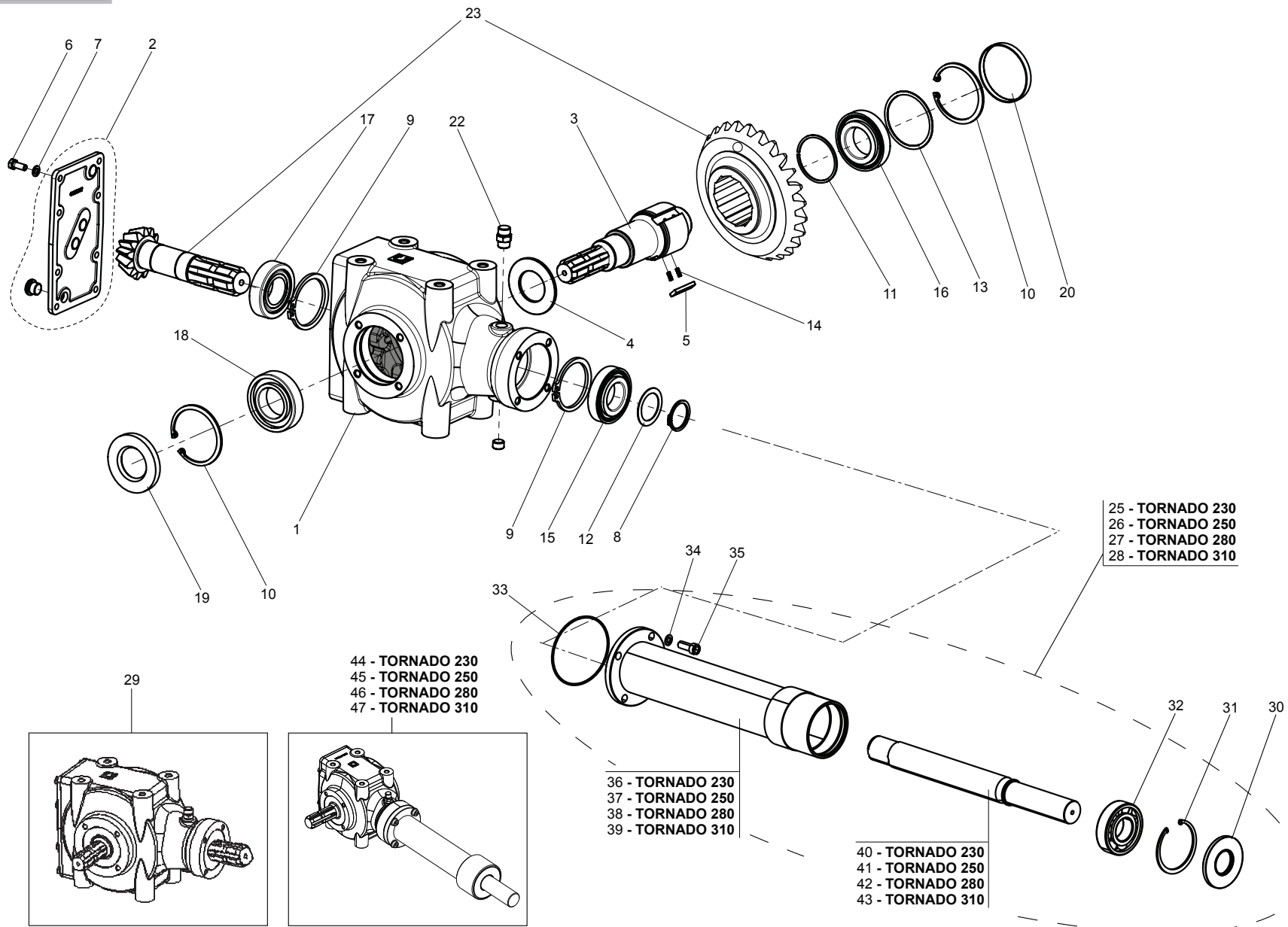

**MOLTIPLICATORE
GEARBOX**

TAV. 020

Pos.	Cod.	Descrizione	Description	Benennung	Description	Descripcion
1	M30500244R	SCATOLA CAMBIO	GEAR-BOX	BOITE DE VITESSES	GETRIEBEGEHAUSE	CAJA CAMBIO
2	M50400908R	COPERCHIO POSTER.	COVER	COUVERCLE	KIT DECKEL POST.	TAPA
3	M30500181R	ALBERO XY 2071 R-RL	SHAFT 2071 R-RL	ARBRE XY 2071 R-RL	WELLE 2071 R-RL	
4	M50400902R	DISTANZIALE	SPACER	ENTRETOISE	DISTANZSTUECK	DISTANCIADOR
5	M50400903R	PIASTRINA	PLATE		PLATTE	
6	F01020436R	VITE M8X1,25X20	SCREW M8X1,25X20 U5739 8.8ZN	VIS M8X1,25X20 U5739 8.8ZN	SCHRAUBE M 8X20	TORN. M8X1,25X20 U5739 8.8ZN
7	F01480099R	ROS.G 8,4X14,4X2,7	GROWER WASHER D.8	GROWER RONDELLE D.8	SPRENGRING D.8	ARANDELA GROWER D.8
8	F03012216R	ANELLO SEEGER 35X2.50 DIN471 2	SNAP RING 35X2.50 DIN 471 2	BAGUE SEEGER 35X2.50 DIN471 2		
9	F02050403R	ANELLO E. DI 72X 2,5 U7437 C7	SEEGER RING E.72X2,5 U7437 C70	SEEGER E. 72X 2,5 U7437 C70	SEEGERING E. 72X 2,5 U7437 C70	ANILLO E. DI 72X 2,5 U7437 C7
10	F02050436R	ANELLO SEEGER D.85 UNI 7437	SEEGER RING E.85X 3 U7437 C70		SEEGERRING D.85	
11	M50400909R	ANELLO EL. E. 68 X1,70	ELASTIC RING 68X1,70	BAGUE ELASTE. 68 X1,70	RING EL. E. 68 X1,70	
12	F06280033R	KIT SPESSORE E.35	SHIM KIT E.35			
13	M58100127R	340I08500 KIT SPES.BONDIOLI	REINFORCEMENTS FOR 58100101	RENFORTS POUR 58100101	VERSTAERKERUNGEN II X 58100101	RENFUERZOS PARA 58100101
14	F02400084R	MOLLA X RUOTA LIBERA BONDIOLI	SPRING FOR FREE WHEEL BONDIOLI		FEDER F R FREILAUF BONDIOLI	
15	F04010175R	CUSC.D35 D72 B17 6207	BEARING D35 D72 B17 6207	ROUL. D35 D72 B17 6207	LAGER 6207	COJINETE D35 D72 B17 6207
16	F04010185R	CUSC.D45 D85 B19 6209	BEARING D45 D85 B19 6209	ROULEMENT D45 D85 6209	LAGER D45 D85 6209	COJINETE D45 D85 6209
17	F04050070R	CUSC.D35 D72 T24,25 32207	BEARING D35 D72 T24,25 32207	ROUL. D35 D72 T24,25 32207	LAGER 32207	COJINETE D35 D72 T24,25 32207
18	F04050018R	CUSC. D45 D85 T20,75 30209	BEARING D45 D85 T20,75 30209	ROULEMENT D45 D85 T20,75 30209	LAGER D45 D85 T20,75 30209	COJINETE D45 D85 T20,75 30209
19	F03010290R	ANELLO T.AS 45X 85X10 D3760NBR	OIL SEAL 45X85X10	PARE-HUILE 45X85X10	OELABDICHTUNG 45X85X10	PARA-ACEITE 45X85X10
20	M50400906R	TAPPO CHIUSURA 85X10	CLOSURE TAP 85X10			
22	F03150718R	TAPPO 3 8 GAS CON SFIATO	GAS BREATHER PLUG 3 8	BOUCHON D HUILE SOUPIRAIL	OELENTLUEFTERSTOPFEN	TAPON ACEITE
23	M30500243R	COPPIA CONICA	BEVEL GEAR PAIR	COUPLE CONIQUE	KEGELRITZELSATZ	PAR CONICO
25	M31423102R	PROLUNGA ALBERO TRASMISSIONE	TRANS. SHAFT EXTENSION	RALLONGE ARBRE DE TRANSMISS.	VERLZNGERUNG ANTRIEBSWELLE	EXTENSION ARBOL TRANS.
26	M31425102R	PROLUNGA ALBERO TRASMISSIONE	TRANS. SHAFT EXTENSION	RALLONGE ARBRE DE TRANSMISS.	TRANS. WELLE VERL NGERUNG	EXTENSION ARBOL TRANS.
27	M31428102R	PROLUNGA ALBERO TRASMISSIONE	TRANS. SHAFT EXTENSION	RALLONGE ARBRE DE TRANSMISS.	VERLZNGERUNG ANTRIEBSWELLE	EXTENSION ARBOL TRANS.
28	M31431102R	PROLUNGA ALBERO TRASMISSIONE	TRANS. SHAFT EXTENSION	RALLONGE ARBRE DE TRANSMISS.	VERLZNGERUNG ANTRIEBSWELLE	EXTENSION ARBOL TRANS.
29	M31400101R	SCATOLA MOLTIPL.540 BONDIOLI	COMPLETE GEARBOX	BOITE DE VITESSE	WECHSELGETRIEBE	CAJA CAMBIO COMPLETA
30	F03010294R	ANELLO T.AS 45X100X10 D3760NBR	RING T.AS 45X100X10 D3760NBR	BAGUE T.AS 45X100X10 D3760NBR	LABDICHTUNG 45X100X10	PARA-ACEITE 45X100X10
31	F02050471R	ANELLO E. DI100X 3 U7437 C70	SEEGER RING D.100	BAGUE SEEGER D.100	SEEGERING D.100	ANILLO SEEGER D.100
32	F04010222R	CUSC.D45 D100 B25 6309	BEARING D45 D100 B25 6309	ROUL. D45 D100 B25 6309	LAGER 6309	COJINETE D45 D100 B25 6309
33	M30500161R	ANELLO OR 72.69X2.62	GASKET OR 72.69X2.62	BAGUE OR 72.69X2.62	1.38.727026 RING.OR.72.69X2.62	ANILLO OR 72.69X2.62
34	F01410066R	ROSSETA M10 10,5X16X1	WASHER M10 10,5X16X1	RONDELLE M10 10,5X16X1	SCHEIBE M10 10,5X16X1	ARAND. M10 10,5X16X1
35	F01040121R	VITE M10X1,5X35	SCREW M10X1,5X35	VIS M10X1,5X35 U5931 8.8ZN	SCHRAUBE M10X1,5X35	TORNIL. M10X1,5X35 U5931 8.8ZN
36	M30500247R	COMP. TUBO L788	TUBE L788			
37	M30500245R	COMP. TUBO 938 1116	TUBE 938 1116			
38	M30500249R	COMP.TUBO L1038	TUBE L1038			
39	M30500251R	COMP.TUBO L1358	TUBE L1358			
40	M30500248R	ALBERO DI TRASMISSIONE	TRANSMISSION SHAFT	ARBRE DE TRANSMISSION 938 L883	ANTRIEBSWELLE	EJE DE TRASMISION
41	M30500246R	ALBERO DI TRASMISSIONE	TRANSMISSION SHAFT	ARBRE DE TRANSMISSION	ANTRIEBSWELLE	EJE DE TRASMISION
42	M30500250R	ALBERO DI TRASMISSIONE	TRANSMISSION SHAFT	ARBRE TRANSMISSION 938 L1133	ANTRIEBSWELLE	EJE DE TRASMISION
43	M30500252R	ALBERO DI TRASMISSIONE	TRANSMISSION SHAFT	ARBRE DE TRANSMISSION	ANTRIEBSWELLE	EJE DE TRASMISION
44	M31423201R	MOLTIPLIC.BOND.540 L= 990	MULTIPLICATOR BOND.540 L= 990		GETRIEBELIC.BOND.540 L= 990	
45	M31425201R	MOLTIPLIC.BOND.540 L= 1115	MULTIPLICATOR BOND.540 L= 1115		GETRIEBE BOND.540 L= 1115	
46	M31428201R	MOLTIPLIC.BOND.540 L= 1240	MULTIPLICATOR BOND.540 L= 1240			
47	M31431201R	MOLTIPLIC.BOND.540 L= 1560	MULTIPLIER.BOND.540 L=1560		GETRIEBELIC.BOND.540 L= 1560	CAJA CAMBIO BOND.540 L= 1560

TAV. 030

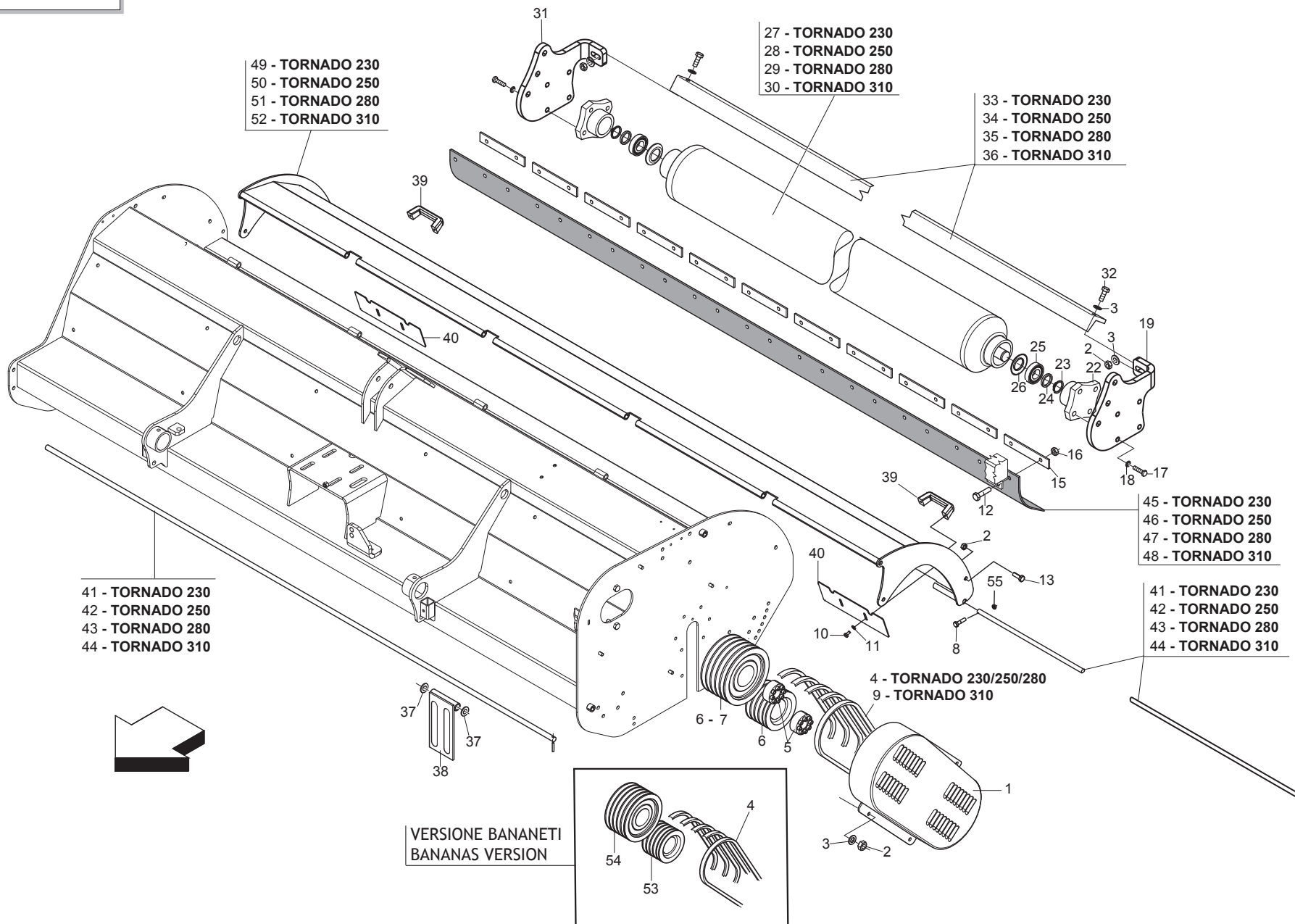

**TELAIO
FRAME**

TAV. 030

Pos.	Cod.	Descrizione	Description	Benennung	Description	Descripcion
1	M63400305R	COMPCARTER LEOPARD ST	CARTER LEOPARD ST			
2	F01220047R	DADO M12X1,25	NUT M12X1,25	ECROU M12X1,25 D980 8ZN	SELBSTSP.MUTTER M12X1,25 980-V	TUERCA M12X1,25 D980 8 ZN
3	F01410076R	ROS.M1213X24X2,5	WASHER 12 13X 24X2,5	RONDELLE 12 13X 24X2,5	SCHEIBE D12 UNI 6592 ZN	ARAND.M12 13X 24X2,5 U6592 ZN
4	F06010067R	CINGHIA XPB L=1800	BELT L=1800	COURROIE L=1800	RIEMEN L=1800	CORREA L=1800
5	F06060039R	CALETTATORE AUTOCENTR.45X80	SELF CENTR.CLAMPEL.45X80	EMBOITEMENT AUTOBLOCANT 45X80	SELBSTPERR.VERKEILEN 45X80	
6	T40005126R	PULEGGIA D.224 5V	PULLEY	POULIE	KEILRIEMENSCHLEIBE D 224 5V	POLEA
7	T40005120R	PULEGGIA D=2505V TORN.230-280	PULLEY TORNADO 230-250-280	POULIE TORNADO 230-250-280	KEILRIEMENSCHLEIBE D 250 5V	POLEA TORNADO 230-250-280
8	F01040066R	VITE M6X1X35	SCREW M6X1X35	VIS M6X1X35 U5931 8.8ZN	SCHRAUBE 6 X35 5931 8.8 ZN	TORNILLO M6X1X35 U5931 8.8ZN
9	F06010069R	CINGHIA XPB L=1750	BELT XPB L=1750	COURROIE L=1750	RIEMEN L=1750	CORREA L=1750
10	F01020432R	VITE M8X1,25X16	SCREW M8X1,25X16 U5739 8.8ZN	VIS M8X1,25X16 U5739 8.8ZN	SCHRAUBE M 8X16	TORN. M8X1,25X16 U5739 8.8ZN
11	F01410051R	ROS.M8 8,4X 17X1,6	WASHER M8 8,4X17X1,6	RONDELLE M8 8,4X17X1,6	SCHEIBE D.8	ARAND.M8 8,4X 17X1,6 U6592 ZN
12	F01020436R	VITE M8X1,25X20	SCREW M8X1,25X20 U5739 8.8ZN	VIS M8X1,25X20 U5739 8.8ZN	SCHRAUBE M 8X20	TORN. M8X1,25X20 U5739 8.8ZN
13	F01010288R	VITE M12X1,25X35	SCREW M12X1,25X35 U5740 8.8ZN	VIS M12X1,25X35 U5740 8.8ZN	SCHRAUBE M12X1,25X35	TORNIL.M12X1,25X35 U5740 8.8ZN
15	M07400953R	PIATTO PER ATTACCO GOMMA	PLATE	PLAT	PLATTE	PLATO
16	F01220022R	DADO M8X1,25	NUT M8X1,25	CROU M8X1,25 D980 ZN	SELBSTSP.MUTT. M8X1,25 980-V	TUERCA M8X 1,25 D980 8 ZN
17	F01010283R	VITE M12X1,25X30	SCREW M12X1,25X30 U5740 8.8ZN	VIS M12X1,25X30 U5740 8.8ZN	SCHRAUBE M 12X1,25X30	TORNIL.M12X1,25X30 U5740 8.8ZN
18	F01480123R	ROS.G 12,5X22,9X 4	GROVER WASHER M12 ZGP EXTRA P.	GROVER RONDELLE M12 ZGP EXTRA	UNTERLEGSCHLEIBE M12 ZGP EXTRA	ARANDELA M12 ZGP EXTRA P.
19	M31400917R	STAFFA ATTACCO RULLO SX	LEFT ROLLER SUPPORT	SUPPORT ROULEAU GAUCHE	SCHUTZHOLM WALZE LINKS	SOPORTE RODILLO IZQUIERDO
22	M23400439R	FLANGIA SUPPORTO H.42	SUPPORT FLANGE H.42	SUPPORT H.42	HALTER H.42	SOPORTE H.42
23	F02050168R	ANELLO E.DE 40X1,75 U7435	SEEGER RING 40X1,75 U7435	BAGUE ELAST. 40X1,75 U7435	SEEGERRING D.40	ANILLO ELAST. 40X1,75 U7435
24	M22400605R	DISTANZIALE RULLO	ROLLER SPACER		DISTANZSTUECK	DISTANZIALE RULLO
25	F04010184R	CUSC.D40 D80 BOMB.18 6208 2RS1	BEARING D40 D80 BOMB.18 6208	ROULEMENT D40 D80 BOMB.18 6208	LAGER D40 D80 BOMB.18 6208 2RS	COJINETE D40 D80 BOMB.18 6208
26	M38100990R	GUARNIZIONE ELASTICA	ELASTIC GASKET	GARNITURE ELASTIQUE	DICHTUNG	JUNTA ELASTICA
27	T25226301R	COMP.ROTORE RULLO TRITONE 230	ROLLER 230	ROTOR ROULEAU 230	KRUMENPACKERWALZE ROTOR 230	ROTOR DE RULO 230
28	T25246301R	COMP.ROTORE RULLO TRITONE 250	CRUMBLER ROLLER ROTOR 250	ROTOR ROULEAU 250	KOMPL.ROTORE ROLLE TRITONE 250	ROTOR DE RULO 250
29	T25286301R	COMP.ROTORE RULLO TRITONE 280	CRUMBLER ROLLER ROTOR 280	ROTOR ROULEAU 280	NACHLAUFWALZE ZUM TORNADO 280	ROTOR DE RULO 280
30	T25316301R	COMP.ROTORE RULLO TRITONE 310	ROLLER TRITONE 310		NACHLAUFWALZE ZUM TORNADO 310	
31	M31400916R	STAFFA ATTACCO RULLO DX	RIGHT ROLLER SUPPORT	SUPPORT ROULEAU DROITE	SCHUTZHOLM WALZE RECHTS	SOPORTE RODILLO DERECHA
32	F01010053R	VITE M12X1,25X45	SCREW M12X1,25X45 U5738 8.8ZN	VIS M12X1,25X45 U5738 8.8ZN	SCHRAUBE M 12X1,25X45	TORNIL.M12X1,25X45 U5738 8.8ZN
33	M34422601R	RASCHIA FANGO TORNADO 230	MUD SCRAPER TORNADO 230		ERD- ABSTREIFER TORNADO 230	
34	M34424601R	RASCHIA FANGO TORNADO 250	MUD SCRAPER TORNADO 250		ERD- ABSTREIFER TORNADO 250	
35	M34429601R	RASCHIA FANGO 280	MUD SCRAPER 280	DECROTTOIR POUR BOUE 280	ABSTREIFER FUR SCHLAMM 280	RASCADOR PARA FANGO 280
36	M34431601R	RASCHIA FANGO L=3032	MUD SCRAPER L=3032	DECROTTOIR POUR BOUE L=3032	ABSTREIFER FUR SCHLAMM L=3032	RASCADOR PARA FANGO L=3032
37	F01410100R	ROS.M16 17X30X 3	WASHER M16 17X30X3	RONDELLE M16 17X30X3	SCHEIBE D.16 UNI 6592 ZN	ARAND.M16 17X 30X 3 U6592 ZN
38	M31400550R	BANDELLA PROTEZIONE L=93 ZN 0	PROTECTION BAR	BANDE PROTECTION	SCHUTZKLAPPE	ALETA PROTECCION
39	F05150112R	MANIGLIA INTERAS. 117 FORO 8MM	HANDLE	POIGNEE	HANDGRIFF	MANILLA
40	M32400806R	PROTEZIONE POSTERIORE COFANO	REAR CARTER PROTECTION		HINT. GEH USE SCHUTZ	
41	T40235032R	ASTA SUPPORTO BANDELLA 230 ZN	ROD 230 ZN	BARRE SUPPORT 230 ZN	STANGE 230 ZN	ASTA SOPORTE 230 ZN
42	T40255032R	ASTA SUPPORTO BANDELLA 250 ZN	ROD 250 ZN	BARRE SUPPORT 250 ZN	STANGE 250 ZN	ASTA SOPORTE 250 ZN
43	T40285032R	ASTA PER COPERCHIO 280 Z.P.G.	ROD 280 ZN	BARRE SUPPORT 280 ZN	STANGE 280 ZN	ASTA SOPORTE 280 ZN
44	T40315032R	ASTA PER COPERCHIO MS310	ROD MS310	TIGE MS310	STANGE MS310	VARILLA MS310
45	M31423560R	PROTEZ. POST.PVC TORNADO 230	REAR PROTECTION 230	PROTECTION ARRIERE 230	HINTERER SCHUTZ 230	PROTECCION TRASERA 230
46	M31425560R	PROTEZ. POST.PVC TORNADO 250	REAR PROTECTION 250	PROTECTION ARRIERE 250	HINTERER SCHUTZ 250	PROTECCION TRASERA 250
47	M31428560R	PROTEZ. POST.PVC TORNADO 280	REAR PROTECTION 280	PROTECTION ARRIERE 280	HINTERER SCHUTZ 280	PROTECCION TRASERA 280
48	M31431560R	PROTEZ. POST.PVC TORNADO 310	REAR PROTECTION 310	PROTECTION ARRIERE 310	HINTERER SCHUTZ 310	PROTECCION TRASERA 310
49	M32423702R	COFANO POST.GEMELLA 230	REAR BONNET GEMELLA 230		HINT. BONNET GEMELLA 230	
50	M32425702R	COFANO POST.TORNADO 250	BACK COVER TORNADO250		BACK DECKEL TORNADO250	
51	M32428702R	COFANO POST.TORNADO 280	BACK COVER TORNADO 280		HECK DECKEL TORNADO 280	
52	M32431702R	COFANO POST.GEMELLA 310	REAR BONNET GEMELLA 310		HECK HAUBE GEMELLA 310	
53	T40005128R	PULEGGIA D=200 5V	PULLEY	POULIE	KEILRIEMENSCHLEIBE	ROLDANA
54	M63400302R	PULEGGIA D=280 GOLE 5	PULLEY D=280 GOLE 5		RIEMENSCHLEIBE D=280 GOLE 5	
55	F01220011R	DADO M6X1	NUT M6X1	CROU M6X1 D980 8ZN	SELBSTSPERR.MUTTER M6	TUERCA M6X1 D980 8 ZN

TAV. 040

- 23 - TORNADO 230
- 24 - TORNADO 250
- 25 - TORNADO 280
- 26 - TORNADO 310
- 31 - TORNADO 230
(VERSIONE BANANETI)
(BANANAS VERSIONS)

Rotore montato con coltelli *Rotor with knives assembly*

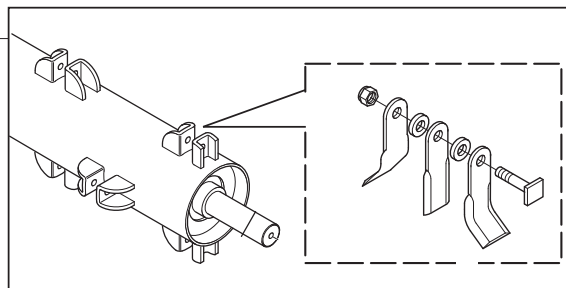

Rotore montato con mazze *Rotor with hammers assembly*

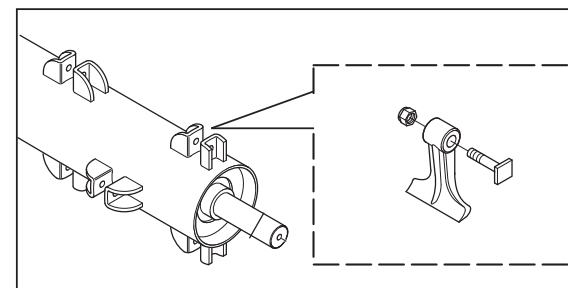

- 27 - TORNADO 230
- 28 - TORNADO 250
- 29 - TORNADO 280
- 30 - TORNADO 310

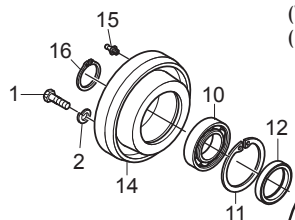

KIT COLTELLI 05

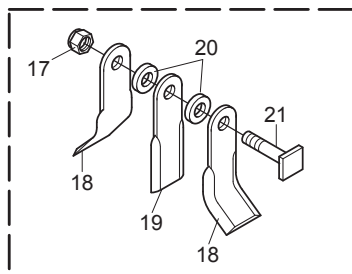

KIT MAZZE 16

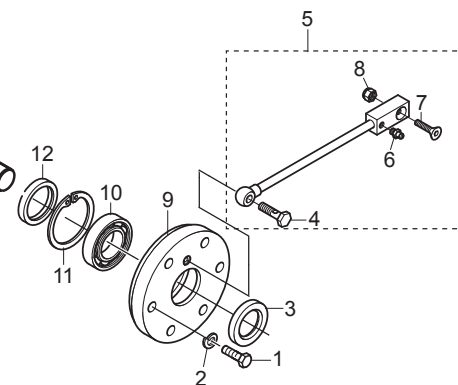
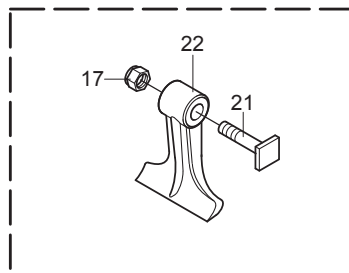

**RULLO
ROLLER**

TAV. 040

Pos.	Cod.	Descrizione	Description	Benennung	Description	Description
1	F01010288R	VITE M12X1,25X35	SCREW M12X1,25X35 U5740 8.8ZN	VIS M12X1,25X35 U5740 8.8ZN	SCHRAUBE M12X1,25X35	TORNIL.M12X1,25X35 U5740 8.8ZN
2	F01410076R	ROS.M1213X24X2,5	WASHER 12 13X 24X2,5	RONDELLE 12 13X 24X2,5	SCHEIBE D12 UNI 6592 ZN	ARAND.M12 13X 24X2,5 U6592 ZN
3	F03010313R	ANELLO T.AS 55X 80X10 D3760NBR	OIL SEAL 55X 80X10 D3760NBR	BAGUE T.AS 55X 80X10 D3760NBR	OELABDICHTUNG 55X80X10	ANILLO T.AS 55X 80X10 D3760NBR
4	T24004003R	VITE FORATA PER INGRASSAGGIO	BOLT	VIS	SCHRAUBE	TORN.PERFORADO PARA ENGRASAR
5	T24004000R	ASSIEME INGRASSATORE	GREASE NIPPLE	GRAISSEUR	SCHMIERROHR	ENGRASADOR
6	F01100011R	ING.M 6X1 7663A 9SMNPB28 Z	GREASE NIPPLE M6X1 7663-A ZN	GRAISS. A BILLE M6X1 7663A ZN	KUGELFETTBUCHSE M6X1 A	ENG.M 6X1 7663-A 9SMNPB28 ZN
7	F01030058R	VITE M8X1,25X30	SCREW M8X1,25X30	VIS M8X1,25X30 U5933 10.9ZD	SCHRAUBE M8X1,25X30 U5933 10,9	TORN. M8X1,25X30 U5933 10.9ZD
8	F01220022R	DADO M8X1,25	NUT M8X1,25	CROU M8X1,25 D980 ZN	SELBSTSPMUTT. M8X1,25 980-V	TUERCA M8X 1,25 D980 8 ZN
9	M03400456R	SUPPORTO ROTORE SX	LEFT ROTOR SUPPORT		ROTORHALTER	
10	F04010033R	CUSC.D55 D100 B25 22211	BEARING D55 D100 B25 22211	ROUL. D55 D100 B25 22211	LAGER.D55 D100 B25 22211	COJINETE D55 D100 B25 22211
11	F02050471R	ANELLO E. DI100X 3 U7437 C70	SEEGER RING D.100	BAGUE SEEGER D.100	SEEGERRING D.100	ANILLO SEEGER D.100
12	F03010218R	ANELLO T.A. 65X100X10 D3760NBR	OIL SEAL 65X100X10	PARE-HUILE 65X100X10 D3760NBR	SCHUTZRING 65X100X10 D3760 NBR	ANILLO 65X100X10
14	M03400455R	SUPPORTO ROTORE DX	RIGHT ROTOR SUPPORT		ROTORHALTER	
15	F01100011R	ING.M 6X1 7663A 9SMNPB28 Z	GREASE NIPPLE M6X1 7663-A ZN	GRAISS. A BILLE M6X1 7663A ZN	KUGELFETTBUCHSE M6X1 A	ENG.M 6X1 7663-A 9SMNPB28 ZN
16	F02050215R	ANELLO E. DE 55X 2 U7435 C70	RET. RING FOR SHAFT 55X2 U7435	BAGUE ELASTIQUE UNI 7435	SEEGERRING D.55	ANILLO UNI 7435
17	F01230258R	DADO M20X1,5	NUT M20X1,5	ECROU M20X1,5 U7474 8SZN	SELBSTSPERR.MUTTER M20X1,5	TUERCA M20X1,5 U7474 8SZN
18	T40005142R	COLTELLO A Y L=210	BLADE Y L=210	COUTEAU Y L=210	MESSER 02 03 05 45	CUCHILLA Y L=210
19	T40005141R	COLTELLO DIRITTO L=210	KNIFE STRAIGHT L=210	COUTEAU DROIT L=210	MESSER 05 GERADE	CUCHILLA L=210
20	T40005140R	DISTANZIALE COLTELLO DIRITTO	SPACER	ENTRETOISE COUTEAU DROIT	SCHEIBE 05	ARANDELA CUCHILLO
21	T40005131R	PERNO COLTELLI ZG	BLADE PIN ZN	GOUJON COUTEAUX ZN	SCHRAUBE	PERNO
22	T30004027R	MAZZA 16 STAMPATA RINFORZATA	HAMMER 16	MARTEAU 16		MARTILLO 16 REFORZADO
23	MSP000009R	COMP.ROTOR.C05EL NOSUP.TOR.230	ROTOR C05EL NOSUP.TOR.230		ROTOR C05EL NOSUP.TOR.250	
24	M047254011R	COMP.ROTOR.C05EL NOSUP.TOR.250	ROTOR C05EL NOSUP.TOR.250		ROTOR C05EL NOSUP.TOR.280	
25	MSP000019R	COMP.ROTOR.C05EL NOSUP.TOR.280	ROTOR C05EL NOSUP.TOR.280		ROTOR C05EL TOR.310	
26	MSP000024R	COMP.ROTOR.C05EL NOSUP.TOR.310	ROTOR C05EL TOR.310			
27	MSP000011R	COMP.ROTSX.M16EL NOSUP.TOR.230	LEFT ROTOR M16EL NOSUP.TOR.230			
28	M047254031R	COMP.ROTSX.M16EL NOSUP.TOR.250	LEFT ROTOR M16EL NOSUP.TOR.250		LI. ROTOR M16EL NOSUP.TOR.250	
29	MSP000021R	COMP.ROTSX.M16EL NOSUP.TOR.280	LEFT ROTOR M16EL NOSUP.TOR.280		LI. ROTOR M16EL NOSUP.TOR.280	
30	MSP000026R	COMP.ROTSX.M16EL NOSUP.TOR.310	LEFT ROTOR M16EL NOSUP.TOR.310		LI. ROTOR M16EL NOSUP.TOR.310	
31	M314234121R	COMP.ROT.C05EL.NOSUP.TORN.230	BLADE 05 HELICOIDAL ROTOR			

**ROTORE
ROTOR**

TAV. 050

Pos.	Cod.	Descrizione	Description	Benennung	Description	Description
1	F01010288R	VITE M12X1,25X35	SCREW M12X1,25X35 U5740 8.8ZN	VIS M12X1,25X35 U5740 8.8ZN	SCHRAUBE M12X1,25X35	TORNIL.M12X1,25X35 U5740 8.8ZN
2	M31400532R	SLITTA	SKID TORNADO	GLISSIERE	GLEITKUFE	TRINEO
3	G13710561R	SCONTRO A U SP.10 2F16,5 118	U-SHAPED PLAT.SP.10 2F16,5 118		INNERER U-ANSCHLAG 118 VERST-R	
6	F01010281R	VITE M12X1,25X25	SCREW M12X1,25X25 U5740 8.8ZN	VIS M12X1,25X25 U5740 8.8ZN	SCHRAUBE M12X1,25X25	TORNIL.M12X1,25X25 U5740 8.8ZN
8	F01220047R	DADO M12X1,25	NUT M12X1,25	ECROU M12X1,25 D980 8ZN	SELBSTSP.MUTTER M12X1,25 980-V	TUERCA M12X1,25 D980 8 ZN
9	M58100930R	CATENELLA L=476	ASSEMBLY CHAIN DMP L=476	CHAINE L=476	KETTE L=476	CADENA L=476
10	F02200529R	SPINA SCATTO D.11 H58 ZN	SNAP PIN D.11 H58 ZN	FICHE A DETENTE D.11 H58 ZN	EINRASTSTIFT D.11 ZB	CLAVIJA DE MUELLE D.11 H58 ZN
11	F02010111R	GHIERA AU.GUP M30X1,5 T.4H ZN	SELF LOCKING NUT M30X1,5	COLLIER AUTOBL. M30X1,5	SELBSTSP. NUTMUTTER M30X1,5	VIROLA AUTOBL. M30X1,5
12	F01010133R	VITE M16X1,5X160	SCREW M16X1,5X160 U5738 8.8ZN	VIS M16X1,5X160 U5738 8.8ZN	SCHRAUBE M16X1,5X160	TORNIL.M16X1,5X160 U5738 8.8ZN
13	M31400622R	COMPOSTO ATTACCO RUOTE	WHEEL SUPPORT ASSY	ATTELAGE ROUE	RAEDER VERBINDUNG	SOPORTE RUEDAS
14	F01410100R	ROS.M16 17X30X 3	WASHER M16 17X30X3	RONDELLE M16 17X30X3	SCHEIBE D.16 UNI 6592 ZN	ARAND.M16 17X 30X 3 U6592 ZN
15	F01220070R	DADO M16X1,5	NUT M16X1,5	ECROU M16X1,5 D980 10ZN	MUTTER M16X1,5	TUERCA M16X1,5 D980 10ZN
16	M31400618R	COMP.SNODO RUOTA CON BOCCOLEZG	ARTICULATED WHEELS JOINT	JOINT ROUES	GELENK RAEDER	SOPORTE ARTICULADO RUEDAS
17	F01010120R	VITE M16X1,5X80	SCREW M16X1,5X80 U5738 8.8ZN	VIS M16X1,5X80 U5738 8.8ZN	SCHRAUBE M 16X1,5X80	TORNIL. M16X1,5X80 U5738 8.8ZN
18	F01010116R	VITE M16X1,5X60	SCREW M16X1,5X60 U5738 8.8ZN	VIS M16X1,5X60 U5738 8.8ZN	SCHRAUBE M 16X1,5X60	TORNIL. M16X1,5X60 U5738 8.8ZN
19	F01100061R	ING.M10X1 7663A 9SMNPB28 Z	GREASE NIPPLE M10X1 7663-A ZN	GRAISSEUR M10X1 7663-A ZN	SCHMIERNIPPEL M10X1	ENGRASADOR M10X1 7663-A ZN
20	M32400550R	COMP.SEMIASSE RUOTA	COMPL. WHEEL SEMIAXLE SHAFT		HALBACHSE RAD	
21	F06120096R	RUOTA 200 60-14.5 10PR FL.5F	WHEEL 200 60-14.5 2004	ROUE 200 60-14.5 2004	RAD 23X8,50-12 6PR	RUEDA 200 60-14.5 2004
22	M07400589R	COMP.PERNO D=30 L=179	PIN	GOUJON	STIFT	PERNO
23	T40005192R	ASSIEME PERNO BLOCC. RUOTA ZPG	PIN	AXE	BOLZEN	PERNO
24	M07400929R	BOCCOLA D=30 D=40 L=30	BUSHING D=30 D=40 L=30	BOUCLE D=30 D=40 L=30	BUECHSE D=40 D=30 L=30	ARANDELA D=30 D=40 L=30
25	M31423930R	LAMIERA ANTIUSURA	DOUBLE SKIN FRAME TORNADO 230	TOLE DE BLINDAGE	SCHLEISSBLECH	CHAPA ANTIDESGASTE
26	M31425930R	COMP. ANT CONT.LAM.TORNADO 250	DOUBLE SKIN FRAME TORNADO 250			
27	M31428930R	COMP. ANT CONT.LAM.TORNADO 280	DOUBLE SKIN FRAME TORNADO 280		KOMPL.ANT CONT.LAM.TORNADO 280	
28	M31431930R	LAMIERA ANTIUSURA	DOUBLE SKIN FRAME TORNADO 310	TOLE DE BLINDAGE	SCHLEISSBLECH	CHAPA ANTIDESGASTE

TAV. 060

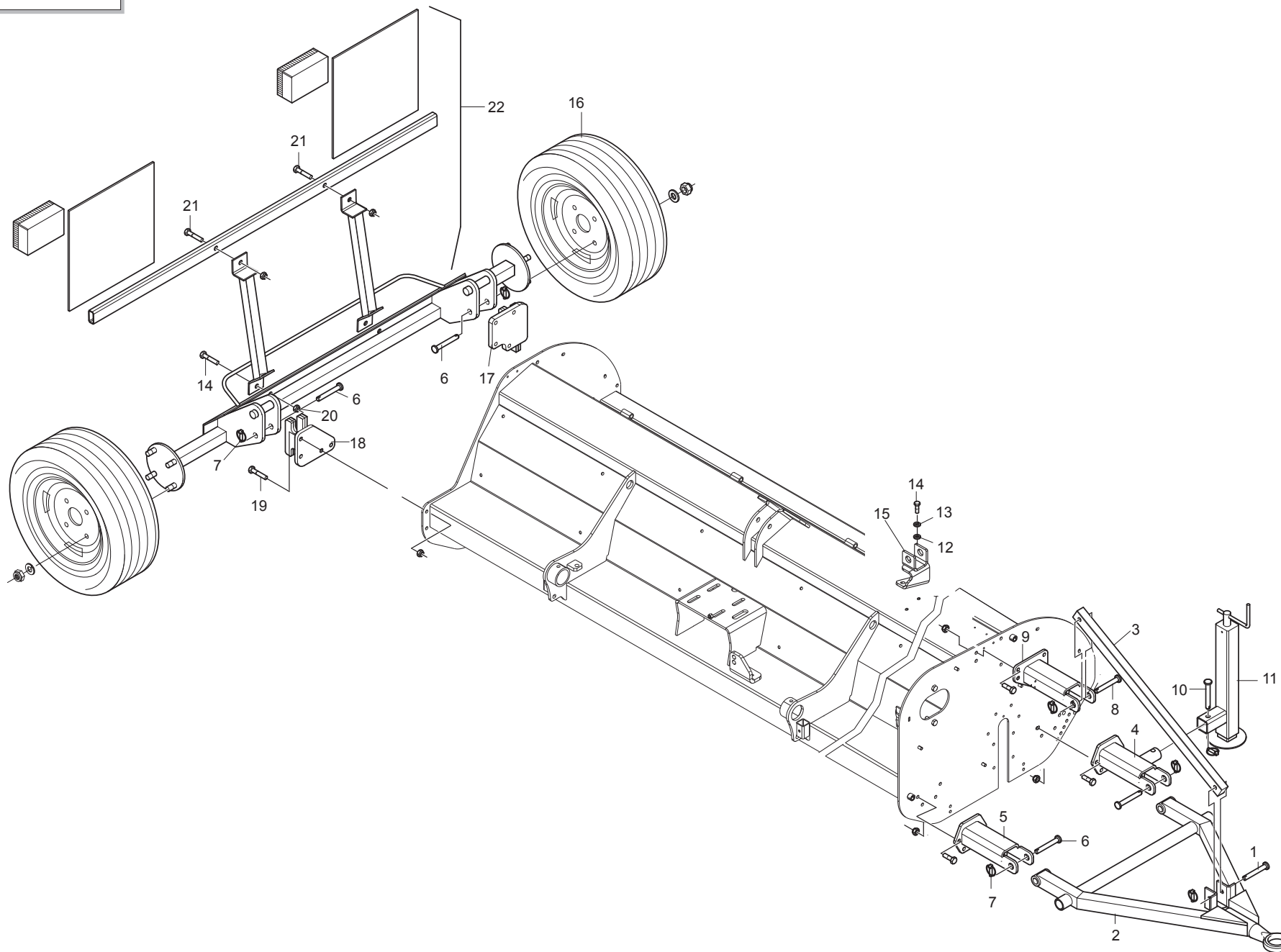



**SLITTE, LAMIERA ANTIUSURA E RUOTE STERZANTI POSTERIORI
SKIDS, DOUBLE SKIN AND REAR STEERING WHEELS**

TAV. 060

Pos.	Cod.	Descrizione	Description	Benennung	Description	Description
1	F20100063R	PERNO D25 L91 C43 TEST.D35 ZN	PIN D25 L91 C43 TEST.D35 ZN	GOUJON D25 L91 C43 TEST.D35ZN	BOLZEN GASPARDO D25 L113 C40	PERNO D25 L91 C43 TEST.D35 ZN
2	M14400595R	TIMONE DI TRAINO	DRAWBAR	TIMON	SEITENSTEUER	TIRANTE
3	M14400971R	TIRANTE TIMONE	TIE ROD	TIRANT	ZUGSTANGE	TIRANTE
4	M31400901R	COMP.AGGANCIO TIMONE TORNADO	DRAWBAR SIDE LINKAGE	ATTELAGE TIMON	STEUER SEITENVERBINDUNG	ATAQUE LATERAL TIRANTE
5	M31400902R	COMP.AGGANCIO TIMONE TORNADO	DRAWBAR SIDE LINKAGE	ATTELAGE TIMON	STEUER SEITENVERBINDUNG	ATAQUE LATERAL TIRANTE
6	F20100139R	PERNO D32 L135 C43 TEST.D60 Z	PIN D32 L135 C43 TEST.D60 ZN	GOUJON D32 L135 C43 TEST.D60ZN	BOLZEN D32 L135 C40 ZN	PERNO D32 L135 C43 TEST.D60 ZN
7	F02200529R	SPINA SCATTO D.11 H58 ZN	SNAP PIN D.11 H58 ZN	FICHE A DETENTE D.11 H58 ZN	EINRASTSTIFT D.11 ZB	CLAVIJA DE MUELLE D.11 H58 ZN
8	F20100133R	PERNO D25 L122 C43 TEST.D60 ZN	PIN D25 L122 C43 TEST.D60 ZN	GOUJON D25 L122 C43 TEST.D60ZN	BOLZEN D25 L128 ZN	PERNO D25 L122 C43 TEST.D60 ZN
9	M31400905R	COMP.AGGANCIO TIMONE TORNADO	DRAWBAR UPPER LINKAGE	ATTELAGE TIMON	STEUER OBERVERBINDUNG	ATAQUE SUPERIOR TIRANTE
10	F20100035R	PERNO D19 L90 C43 TEST.D35 ZN	PIN D19 L90 C43 TEST.D35 ZN	GOUJON D19 L90 C43 TEST.D35 ZN	BOLZEN	PERNO D19 L90 C43 TEST.D35 ZN
11	M14400933R	PIEDE DI SOLLEVAMENTO	FEET SUPPORTING	SUPPORT FRAISE	FRASE STANDER	SOPORTE FRESADORA
12	F01410076R	ROS.M1213X24X2,5	WASHER 12 13X 24X2,5	RONDELLE 12 13X 24X2,5	SCHEIBE D12 UNI 6592 ZN	ARAND.M12 13X 24X2,5 U6592 ZN
13	F01480123R	ROS.G 12,5X22,9X 4	GROVER WASHER M12 ZGP EXTRA P.	GROVER RONDELLE M12 ZGP EXTRA	UNTERLEGSCHIEBE M12 ZGP EXTRA	ARANDELA M12 ZGP EXTRA P.
14	F01010288R	VITE M12X1,25X35	SCREW M12X1,25X35 U5740 8.8ZN	VIS M12X1,25X35 U5740 8.8ZN	SCHRAUBE M12X1,25X35	TORNIL.M12X1,25X35 U5740 8.8ZN
15	M31400923R	COMPOSTO AGGANCIO TIRANTE	COMPLETE STRETCHER HOOK		KOMPL. STRETCHER HAKEN	
16	F06120096R	RUOTA 200 60-14.5 10PR FL.5F	WHEEL 200 60-14.5 2004	ROUE 200 60-14.5 2004	RAD 23X8,50-12 6PR	RUEDA 200 60-14.5 2004
17	M31400908R	SUPPORTO RUOTA SX	LEFT WHEEL SUPPORT	SUPPORT ROVE GAUCHE	LINKS RADER HALTER	SOPORTE RVEDA ISQR.
18	M31400907R	SUPPORTO RUOTA DX	RIGHT WHEEL SUPPORT	SUPPORT ROVE DROITE	RECHTS RADER HALTER	SOPORTE RUEDA IZQUIERDA
19	F01010318R	VITE M14X1,5X40	SCREW M14X1,5X40 U5740 8.8ZN	VIS M14X1,5X40 U5740 8.8ZN	SCHRAUBE M 14X1,5X40	TORNIL. M14X1,5X40 U5740 8.8ZN
20	F01220047R	DADO M12X1,25	NUT M12X1,25	ECROU M12X1,25 D980 8ZN	SELBSTSP.MUTTER M12X1,25 980-V	TUERCA M12X1,25 D980 8 ZN
21	F01010295R	VITE M12X1,25X60	SCREW M12X1,25X60 U5740 8.8ZN	VIS M12X1,25X60 U5740 8.8ZN	SCHRA.M12X1,25X60 U5740 8.8 ZN	TORNIL.M12X1,25X60 U5740 8.8ZN
22	M31400914R	GR. BARRA LUCE TORNADO	REAR LIGHTS AND WARNING BOARDS	KIT SIGNALISATION ARRIERE	BELEUCHTUNGSEINRICHTUNG	KIT PARA TRANSPORTE

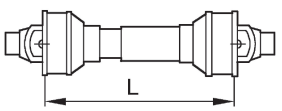
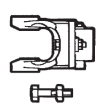
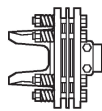
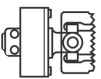
TAV. 070

				
9 - F08011594 L=710	--	--	--	CL 250/ML 230-270

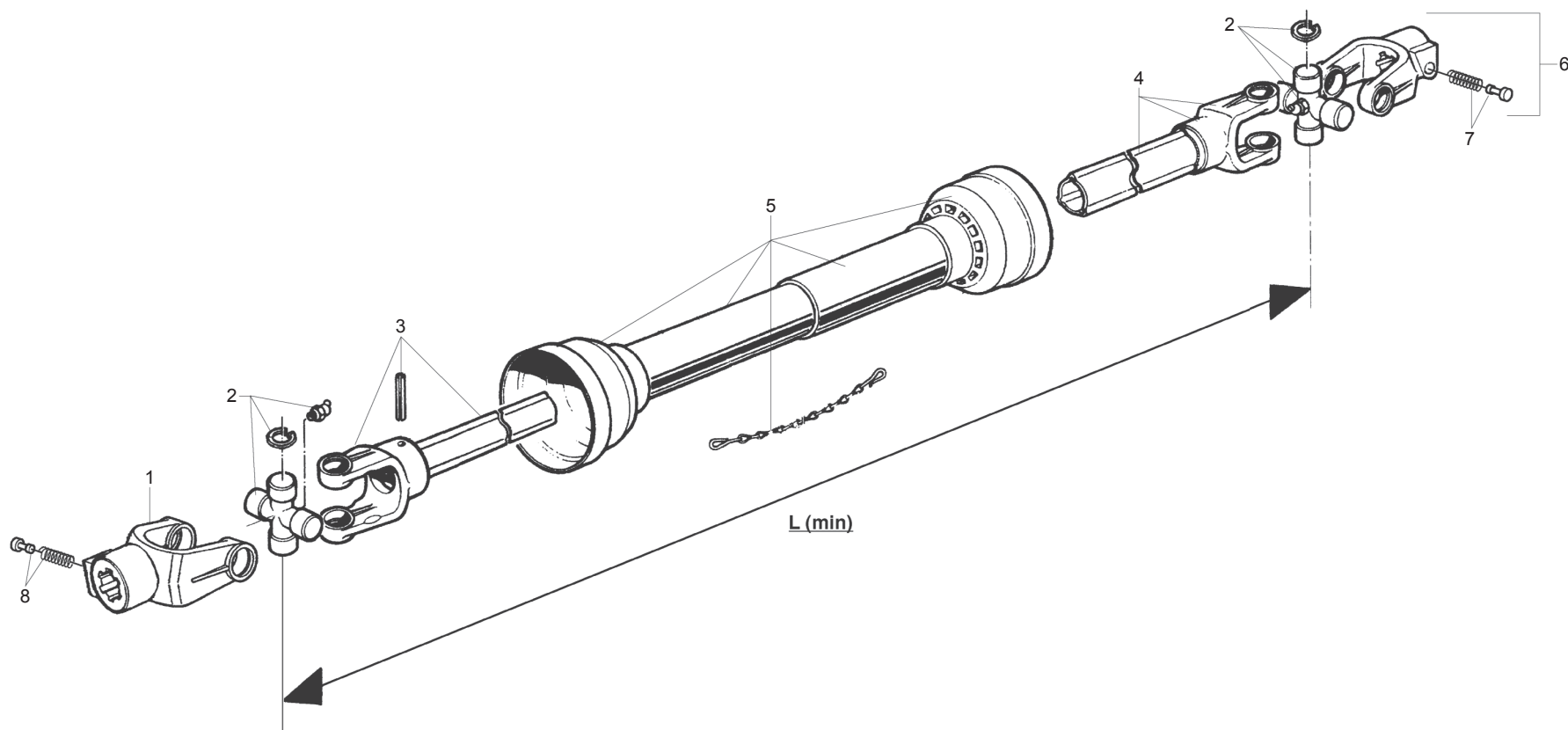

**RUOTE DI TRASPORTO
TRANSPORT WHEELS**

TAV. 070

Pos.	Cod.	Descrizione	Description	Benennung	Description	Description
1	F08010459R	FORCELLA COMP.PULS.-1 3 8 Z6	LINKAGE FORK-1 3 8 Z6	FOURCHE ATTELAGE-1 3 8 Z6	GABELSTUECK-1 3 8 Z6	HORQUILLA ATAQUE-1 3 8 Z6
2	F08010686R	CROCIERA COMPLETA	SPIDER ASSY	CROISIERE COMPL.	GELENKKREUZ KOMPL.	CRUCETA COMPLETA
3	F08010533R	FORCELLA CON TUBO INTERNO	FORK WITH INTERNAL PIPE	FOURCHE AVEC TUYAU INTERIEUR	VEDI 00571104	HORQUILLA CON TUBO INTERNO
4	F08010721R	FORCELLA TUBO ESTERNO	FORK WITH EXTERNAL PIPE	FOURCHE AVEC TUBE EXTERIEUR	GABELST. AUSSENROHR	HORQUILLA TUBO EXTERNO
5	F08010858R	PROTEZIONE COMPLETA	PROTECTION ASSY	PROTECTION COMPL.	KOMPL. SCHUTZ	PROTECCION COMPL.
6	F08010459R	FORCELLA COMP.PULS.-1 3 8 Z6	LINKAGE FORK-1 3 8 Z6	FOURCHE ATTELAGE-1 3 8 Z6	GABELSTUECK-1 3 8 Z6	HORQUILLA ATAQUE-1 3 8 Z6
7	F08011168R	339107 PULSANTE	YOKE PIN 339107	339107 POUSSOIR COMPL.	DRUCKKNOPF KOMPL.	PULSADOR COMPL.
8	F08011168R	339107 PULSANTE	YOKE PIN 339107	339107 POUSSOIR COMPL.	DRUCKKNOPF KOMPL.	PULSADOR COMPL.
9	F08011594R	ALBERO CARDANICO COMPLETO GSM	UNIVERSAL P T O SHAFT		GELENKWELLE W2500,DIREKT	

**USATE SEMPRE RICAMBI ORIGINALI
ALWAYS USE ORIGINAL SPARE PARTS
IMMER DIE ORIGINAL-ERSATZTEILE VERWENDEN
EMPLOYEZ TOUJOURS LES PIECES DE RECHANGE ORIGINALES
UTILIZAR SIEMPRE REPUESTOS ORIGINALES**



**Servizio Assistenza Tecnica - After Sales Service
Servizio Ricambi - Spare Parts Service**



maschio.com

DEALER:



MASCHIO GASPARDO SpA

Registered Office and Production Plant

Via Marcello, 73 - 35011 Campodarsego (Padova) - Italy

Tel. +39 049 9289810

Fax +39 049 9289900

info@maschio.com

www.maschio.com

MASCHIO DEUTSCHLAND GMBH

Außere Nürnberger Straße 5

D - 91177 Thalmässing - Deutschland

Tel. +49 (0) 9173 79000

Fax +49 (0) 9173 790079

dialog@maschio.de

www.maschio.de

MASCHIO FRANCE Sarl

1 rue Denis Papin ZA

F - 45240 La Ferte St. Aubin

France

Tel. +33 (0) 2.38.64.12.12

Fax +33 (0) 2.38.64.66.79

info@maschio.fr

ООО МАСКИО-ГАСПАРДО РУССИЯ

04130, Россия,

Волгоградская область,

г. Волжский, ул. Пушкина, 117 «б».

Тел.: +7 8443 203100

факс: +7 8443 203101

e-mail: info@maschio.ru

MASCHIO GASPARDO SpA

Production Plant

Via Mussons, 7 - 33075 Morsano al Tagliamento (PN) - Italy

Tel. +39 0434 695410

Fax +39 0434 695425

info@gaspardo.it

MASCHIO GASPARDO NORTH AMERICA Inc.

112 3rd Avenue East

DeWitt - IA 52742

Ph. +1 563 6596400

Fax +1 563 6596404

info@maschio.us

MASCHIO-GASPARDO ROMANIA S.R.L.

Strada Înfrăţirii, F.N.

315100 Chisineu-Cris (Arad) -România

Tel. +40 257 307030

Fax +40 257 307040

info@maschio.ro

MASCHIO IBERICA S.L.

MASCHIO-GASPARDO POLAND

MASCHIO-GASPARDO UCRAINA

GASPARDO-MASCHIO TURCHIA

MASCHIO-GASPARDO CINA

MASCHIO-GASPARDO INDIA

MASCHIO-GASPARDO KOREA