

MASCHIO GASPARDO S.p.A.

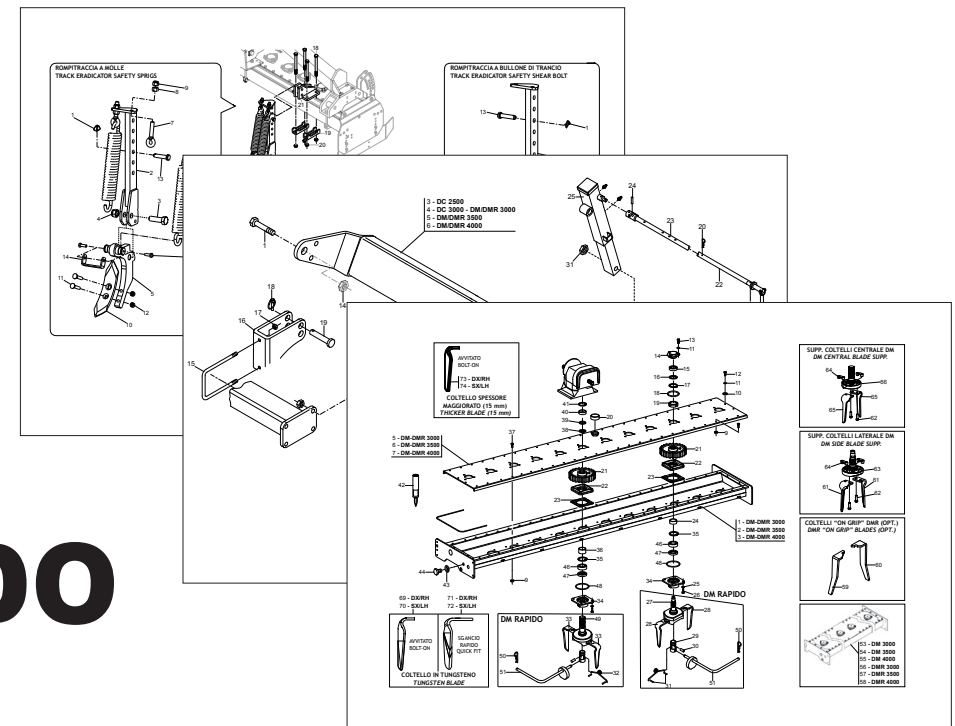

DC - DM - DM RAPIDO COMBI 2

Cod: F07011610 2019-12

- *) Valido per Paesi UE
- *) Valid for EU member countries
- *) Valable dans les Pays UE
- *) Gilt für EU-Mitgliedsländer
- *) Válido para Países UE

- IT** PARTI DI RICAMBIO
- EN** SPARE PARTS
- DE** ERSATZTEILE
- FR** PIÈCES DÉTACHÉES
- ES** PIEZAS DE REPUESTO

PARTI DI RICAMBIO**SPARE PARTS****ERSATZTEILE****PIECES DÉTACHÉES****RESPUESTOS**

Le ordinazioni delle parti di ricambio vanno fatte presso i nostri concessionari di zona e devono essere sempre corredate dalle seguenti indicazioni:

- **Tipo, modello e numero di matricola dell'attrezzatura.** Tali dati sono stampigliati nell'apposita targhetta di cui è dotata ogni attrezzatura.

- **Numero di codice della parte richiesta** rilevabile dal catalogo ricambi.

- **Descrizione del particolare e quantità richiesta.**

- **Numero della tavola.**

- **Mezzo di trasporto.** Nel caso questa voce non sia specificata, la Ditta Costruttrice, pur dedicando a questo servizio una particolare cura, non risponde di eventuali ritardi di spedizione dovuti a cause di forza maggiore.

Le spese di trasporto si intendono sempre a carico del destinatario. La merce viaggia a rischio e pericolo del committente anche se venduta franco destino.

NOTA: Il termine **(Dx) Destro** o **(Sx) Sinistro** della macchina o di parti di essa, è inteso guardando la macchina dalla parte posteriore. Le eccezioni saranno indicate.

Orders must be transmitted through our area dealers and should always include the following indications:

- **Type, model and serial number of the machine.** *These data are punched on the data plate with which every implement is equipped.*

- **Code number of the required spare part.** *This will be found in the spare parts catalogue.*

- **Description of the part and required quantity.**

- **Table number.**

- **Means of dispatch.** *If this item is not indicated, the Manufacturer, while dedicating particular care to this service, shall not be held responsible for delays in delivery caused by cases of force majeure.*

Transport expenses shall always be at the consignee's charge. The goods travel at the purchaser's risk and peril even when sold ex destination.

NOTE: *The symbols (Dx) right and (Sx) left, concerning the machine or single parts of it, are referred, as in the figure, to a rear view of them. Exceptions will be indicated.*

Die Bestellungen müssen bei unseren Gebietshändlern aufgegeben werden. Bei der Bestellung sind stets die folgenden Angaben zu machen:

- **Typ, Modell und Serien-Nummer des Geräts.** Diese Daten stehen auf dem Typenschild, mit dem jedes Gerät versehen ist.

- **Artikel Nr. der erforderlichen Ersatzteile.** Diese stehen im Ersatzteil-Katalog.

- **Beschreibung des Ersatzteils und die erforderliche Stückzahl.**

- **Tafelnummer.**

- **Versandmittel.** Wenn dieser Punkt nicht spezifiziert wird, haftet die Herstellerfirma nicht für etwaigen Lieferverzug aufgrund höherer Gewalt, auch wenn er diesen Service besonders aufmerksam abwickelt.

Die Frachtkosten gehen dagegen immer zu Lasten des Empfängers. Die Ware reist auf Gefahr und Risiko des Auftraggebers, auch wenn frei Haus Verkauft vereinbart worden ist.

N.B.: Die Merkzeichen **(Dx) rechts** und **(Sx) links** betreffen eine rückwärtige Ansicht der Maschine oder Teile von ihr (siehe Bild). Ausnahmen werden gezeigt.

Les ordres doivent être effectués auprès de nos concessionnaires de zone en précisant les indications suivantes:

- **Type, modèle et numéro de série de la machine.** *Ces données sont gravées sur la plaque d'identification de chaque outil.*

- **Numéro de code de la pièce détachée** *indiqué sur le catalogue des pièces détachées.*

- **Description de la pièce et quantité requise.**

- **Numéro de plan.**

- **Moyen d'expédition.** *Si cette rubrique n'est pas indiquée, le Constructeur, bien que soucieux de ce service, ne répond pas des retards d'expédition pour des causes de force majeure.*

Les frais de transport sont toujours à la charge du destinataire. La marchandise voyage aux risques et périls de l'acheteur même si vendue franco de port.

N.B.: *Les références (Dx) droit et (Sx) gauche de la machine ou des parties de la même, est entendue, comme de la figure, en regardant la machine de derriere dans le sens de marche.*

Los pedidos han de efectuarse en nuestros concesionarios de zona y deben incluir siempre las siguientes indicaciones:

- **Tipo, modelo y número de matrícula del equipo.** Dichos datos están impresos en la relativa placa presente en el equipo.

- **Número de código de la parte requerida** presente en el catálogo respuestas.

- **Descripción de la pieza y cantidad requerida.**

- **Numero de ilustración.**

- **Medio de transporte.** En caso que este ítem no esté especificado, el Fabricante, aún prestando la debidas consideraciones para este aspecto, no responde por eventuales retardos de env'o debidos a causas de fuerza mayor.

Los gastos de transporte se consideran siempre a cargo del destinatario. La mercadería viaja bajo riesgo y peligro del comprador, incluso cuando se vende franco destino.

N.B.: La referencia **(Dx) derecha** o **(Sx) izquierda** de la máquina o de sus componentes, se entiende, como en la figura, mirando la máquina por la parte trasera. Se indicarán las excepciones.

INDICE

N° Tavola	Descrizione	Pagina
TAV.011	TELAIO E ROTORI DC	5
TAV.021	TELAIO E ROTORI DM - DMR	7
TAV.031	GRUPPO TERZO PUNTO COMBI	11
TAV.040	GRUPPO CAMBIO.....	13
TAV.040	PROTEZIONI LATERALI.....	17
TAV.050	BARRA LIVELLATRICE.....	19
TAV.060	BRACCIO COLLEGAMENTO RULLO (VERS. COMBI).....	21
TAV.070	CUNEI DEFLETTORI AVVITATI.....	23
TAV.080	GRUPPO PROTEZIONI CE (ANTERIORI).....	25
TAV.090	GRUPPO PROTEZIONI <<CE>> (POSTERIORI).....	27
TAV.100	OPTIONALS.....	29
TAV.110	OPTIONALS.....	31
TAV.120	KIT SUPPORTI PER TRASPORTO STRADALE.....	33
TAV.130	KIT TABELLE STRADALI G99600006.....	35
TAV.140	KIT TABELLE STRADALI G99600017.....	37
TAV.150	KIT TABELLE STRADALI G99600018.....	39
TAV.160	KIT TABELLE STRADALI G99600032.....	41
TAV.170	CARDANO.....	43
TAV.180	CARDANO.....	45
TAV.190	CARDANO.....	47
TAV.200	CARDANO.....	49
TAV.210	CARDANO.....	51
TAV.220	CARDANO.....	53
TAV.230	CARDANO.....	55
TAV.250	TABELLA RULLI.....	56

INDEX

N° Table	Description	Page
TAV.011	FRAME AND ROTORS DC.....	5
TAV.021	FRAME AND ROTORS DM - DMR.....	9
TAV.031	3RD-POINT UNIT COMBI.....	11
TAV.040	GEARBOX.....	13
TAV.040	SIDE PROTECTIONS.....	17
TAV.050	LEVELING BAR.....	19
TAV.060	ROLLER CONNECTING BRACKET (COMBI VERSION).....	21
TAV.070	BOLT-ON STEEL DEFLECTORS.....	23
TAV.080	(FRONT) EC GUARDS UNIT.....	25
TAV.090	(REAR) <<EC>> GUARDS UNIT.....	27
TAV.100	OPTIONALS.....	29
TAV.110	OPTIONALS.....	31
TAV.120	ROAD TRANSPORT SUPPORTS KIT.....	33
TAV.130	ROAD TRANSPORT KIT G99600006.....	35
TAV.140	ROAD TRANSPORT KIT G99600017.....	37
TAV.150	ROAD TRANSPORT KIT G99600018.....	39
TAV.160	ROAD TRANSPORT KIT G99600032.....	41
TAV.170	CARDAN SHAFT.....	43
TAV.180	CARDAN SHAFT.....	45
TAV.190	CARDAN SHAFT.....	47
TAV.200	CARDAN SHAFT.....	49
TAV.210	CARDAN SHAFT.....	51
TAV.220	CARDAN SHAFT.....	53
TAV.230	CARDAN SHAFT.....	55
TAV.250	ROLLER TABLE.....	56

TAV.011

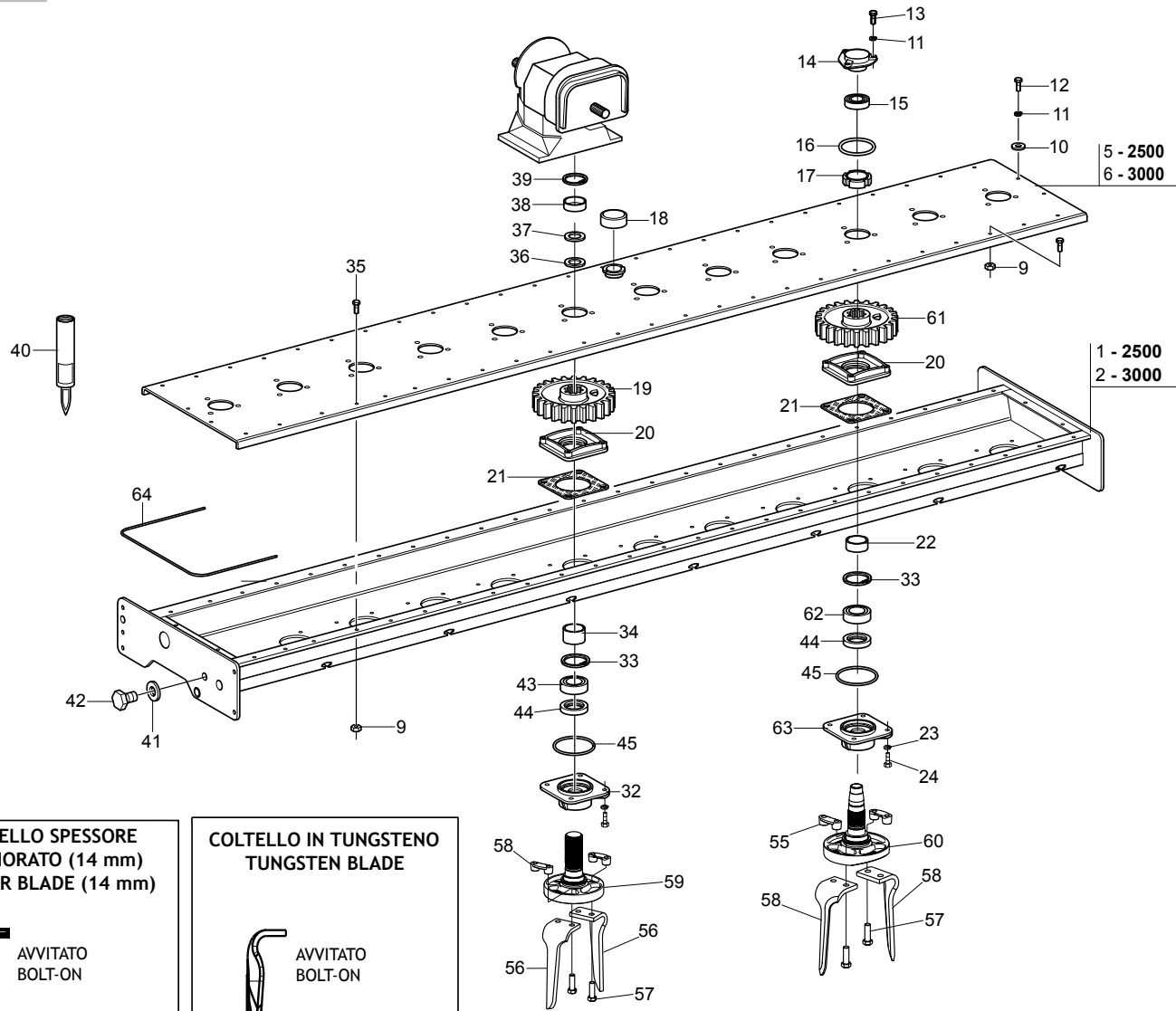

5 - 2500
6 - 3000

1 - 2500
2 - 3000

**COLTELLO SPESSORE
MAGGIORATO (14 mm)
THICKER BLADE (14 mm)**

AVVITATO
BOLT-ON

67 - DX/RH
68 - SX/LH

**COLTELLO IN TUNGSTENO
TUNGSTEN BLADE**

AVVITATO
BOLT-ON

65 - DX/RH
66 - SX/LH

49 - DC 2500
50 - DC 3000

**TELAIO E ROTORI DC
FRAME AND ROTORS DC**

TAV.011

Pos.	Cod.	Descrizione	Description	Benennung	Description	Descrpcion
1	F01220047R	DADO M12X1,25	NUT M12X1,25	ECROU M12X1,25	MUTTER M12X1,25	TUERCA M12X1,25 D980 8 ZN
2	M26430582R	COMP.CORPO TRASMISSIONE L=2992	TRANSMISSION BOX L=2992	BOITE DE TRANSMISSION L=2992	ANTRIEBSKASTEN L=2992	CUERPO TRASMISSION L=2992
5	M23425510R	COMP.COPERCHIO C.TRASM.L=2462	UPPER PLATE L=2462	CAPOT SUPERIEUR L=2462	OBERBLECH L=2462	PLANCHA SUPERIOR L=2462
6	M23430510R	COMP.COPERCHIO C.TRASM.L=2954	UPPER PLATE L=2954	CAPOT SUPERIEUR L=2954	OBERBLECH L=2954	PLANCHA SUPERIOR L=2954
9	F01220034R	DADO M10X1,25	NUT M10X1,25	ECROU M10X1,25	MUTTER M10X1,25	TUER.M10X1,25 D980 8 ZB
10	F01410062R	ROS.M10 10,5X 18X 2	WASHER M10 10,5X 18X 2	RONDELLE M10 10,5X 18X 2	DICHTUNGSRING M10 10,5X18X2 ZN	ARAND.M10 10,5X 18X 2 U6592 ZN
11	F01480112R	ROS.G 10,5X19X 3	GROWER WASHER D.10	GROWER RONDELLE D.10	SCHEIBE GROWER D.10	ARANDELA GROWER D.10
12	F20110012R	VITE M10X1,25X 35	SCREW M 10X1,25X35	VIS M 10X1,25X35	SCHRAUBE M 10X1,25X35	TORNILLO M 10X1,25X35
13	F20110012R	VITE M10X1,25X 35	SCREW M 10X1,25X35	VIS M 10X1,25X35	SCHRAUBE M 10X1,25X35	TORNILLO M 10X1,25X35
14	M38100344R	SUPPORTO CUSCINETTO SUPERIORE	BEARING SUPPORT	SUPPORT ROULEMENT	LAGERHALTER	SOPORTE
15	F04010179R	CUSC.D35 D72 B17 6207 2RSC3	BEARING D35 D72 B17 6207 2RSC3	ROULEMENT D35 D72 B17 6207	LAGER D35 D72 B17 6207 2RSC	COJINETE D35 D72 B17 6207
16	F03010684R	ANELLO OR 94,84X3,53 NGR	GASKET OR 94,84X3,53 NBR	BAGUE OR 94.83X3.53 NBR	RING OR 94,84X3,53 NBR	ANILLO OR 94,84X3,53 NBR
17	F02010144R	GHIERA AU.GUP M45X1,5 T.4H ZN	S.LOCK NUT GUP M45X1.5 T.4H ZN	COLLIER AUTOBL. M45X1,5 T.4H	SELBSTSP. M45X1,5 T.4H ZN	VIROLA AUTOBL. M45X1,5 T.4H
18	F03150746R	TAPPO CARICO OLIO	OIL INLET CAP	BOUCHON HUILE CHARGEMEN	ENTLUEFTERPFROPFEN	CORCHO OLEO
19	M36100306R	INGRANAGGIO LATERALE DM	GEAR	ENGRENAGE LATERAL DM	ZAHNRAD	ENGRANAJE
20	M19400308R	FLANGIA INTERNA	INNER FLANGE	FLASQUE INTERIEUR	INNENFLANSCH	BRIDA INTERNA
21	M27100309R	GUARNIZIONE FLEXOID 5 10	GASKET MM.0,5	JOINT MM.0,5	DICHTUNG MM.0,5	JUNTA MM.0,5
22	M27100306R	DISTANZIALE 50,9X63,5X20,5	SPACER	ENTRETOISE	DISTANZSTUECK	DISTANCIADOR
23	F01480123R	ROS.G 12,5X22,9X 4	GROVER WASHER M12 ZGP EXTRA P.	GROVER RONDELLE M12 ZGP EXTRA	UNTERLEGSCHIEBE M12 ZGP EXTRA	ARANDELA M12 ZGP EXTRA P.
24	F01010289R	VITE M12X1,25X35	SCREW M12X1,25X35	VIS M12X1,25X35	SCHRAUBE M12X1,25X35	TORNILLO M12X1,25X35
32	M19400307R	FLANGIA SUPP.INFERIORE DM	LOWER FLANGE SUPPORT DM		FLANSCH	
33	F02050471R	ANELLO E. DI100X 3 U7437 C70	SEEGER RING D.100	BAGUE SEEGER D.100	SEEGERRING D.100	ANILLO SEEGER D.100
34	M36500313R	DISTANZ. D=67 D=55 L=16.5	SPACER D=67 D=55 L=16.5	ENTRETOISE D=67 D=55 L=16.5	DISTANZSTUECK D=67 D=55 L=16.5	DISTANCIADOR D=67 D=55 L=16.5
35	F01010244R	VITE M10X1,25X25	SCREW M10X1,25X25	VIS M10X1,25X25	SCHRAUBE M10X1,25X25	TORNILLO M10X1,25X25
36	M36500311R	ROSETTA D=65 D=55 L=0,1	WASHER D=65 D=55 L=0,1	ROSETTE D=65 D=55 L=0,1	SCHEIBE D=65 D=55 L=0,1	ARANDELLA D=65 D=55 L=0,1
37	M36500312R	ROSETTA D=65 D=55 L=0.05	WASHER D=65 D=55 L=0.05	ROSETTE D=65 D=55 L=0.05	SCHEIBE D=65 D=55 L=0.05	ARANDELLA D=65 D=55 L=0.05
38	M36500314R	DISTANZ. D=67 D=55 L=14.8	SPACER D=67 D=55 L=14.8	ENTRETOISE D=67 D=55 L=14.8	DISTANZSTUECK D=67 D=55 L=14.8	DISTANCIADOR D=67 D=55 L=14.8
39	F02050204R	ANELLO E. DE 55X 3 U7436 C70	SEEGER RING D.55	BAGUE SEEGER D.55	SEEGERRING D.55	ANILLO D.55
40	F03220010R	POLIURETANO NERO IN CAR.310 M	SEALING PACKAGE	CONFECTION SIGILLANTE	DICHTUNGSMASSE ANFERTIGUNG	CONFECCION SELADURA
41	M26100321R	GUARNIZIONE PER TAPPO OLIO	GASKET	JOINT	DICHTUNG	JUNTA
42	F03150625R	TAPPO CARICO SCARICO M18X1,5	OIL IN OUT CAP M18X1,5	BOUCHON HUILE CHARGEMEN	ENTLUEFTERPFROPFEN	CORCHO OLEO
43	F04010192R	CUSC.D55 D100 B21 6211 53 KN	BEARING D55 D100 B21 6211 53KN	ROULEMENT 6211 AG15	LAGER 6211 AG15	COJINETE 6211 AG15
44	M38100214R	ANELLO COMBI 65X85X13 17	OIL SEAL 65X85X13 17 SPEC.	PARE-HUILE 65X85X13 17 SPEC	OELABDICHTUNG 65X85X13 17SPEC.	PARA-ACEITE 65X85X13 17 SPEC.
45	F03010726R	ANELLO OR 123.43X3.53 NBR	GASKET OR 123.43X3.53 NBR	BAGUE OR D. 123.43X3.53	RING OR 123.43X3.53 NBR	ANILLO OR 123.43X3.53 NBR
49	M26425591R	CORPO TR. DC 2500 STD-COMBI 08	COMPL.BOX DC 2500 STD-COMBI 08			
50	M26430591R	CORPO TR. DC 3000 STD-COMBI 08	COMPL.BOX DC 3000 STD-COMBI 08			
55	M38100218R	FERMO VITE COLTELLI DC-DL-DS	KNIVES FASTENING BOLT	ETRIER SERRAGE COUTEAU DC-DS	MESSERSCHRAUBESPERRUNG	CLAUSURATORNILLOCUCHILLA
56	M27100209R	COLT90X12X280SX 50M16	BLAD90X12X280LH 50M16	COUTEAU GAUCHE DC DS DL 90X12	LINKES MESSER DC DS DL 90X12	CUCHILLO IZQ. DC DS DL 90X12
57	F20110044R	VITE M16X1,5X50	SCREW M16X1,5X50	VIS M16X1,5X50	SCHRAUBE M16X1,5X50	TORNILLO M16X1,5X50
58	M27100210R	COLT90X12X280DX 50M16	BLAD90X12X280RH 50M16	COUTEAU DROIT DC DS DL 90X12	RECHT MESSER DC DS DL 90X12	CUCHILLO DERECH.DC DS DL 90X12
59	M26400309R	SUPPORTO COLTELLI CENTRALE	CENTR. BLADE SUPPORT	SUPPORT COUTEAU CENTRAL DMR	ZENTRALMESSERHALTERUNG	SOPORTE CUCHILLO CENTR.
60	M38100301R	SUPPORTO COLTELLI LATERALE T	SIDE BLADE SUPPORT	SUPPORT COUTEAU LATERAL	SEITENMESSERHALTERUNG	SOPORTE CUCHILLO LATERAL
61	M27100305R	INGRANAGGIO	GEAR	ENGRENAGE	ZAHNRAD	ENGRANAJE
62	F04010188R	CUSC.D50 D90 B20 6210 C3	BEARING D50 D90 B20 6210 C3	ROULEMENT D50 D90 B20 6210 C3	LAGER D50 D90 B20 6210 C3	COJINETE D50 D90 B20 6210 C3
63	M26400306R	FLANGIA SUPP.INFERIORE DC	FLANGE BOTTOM SUPPORT DC	SUPPORT INFERIEUR DC	FLANSCH	BRIDA SOPORTE INFERIOR DC
64	F03011158R	GUARNIZIONE IN SILICONE D=6	GASKET D=6	JOINT D=6	DICHTUNG D=6	JUNTA D=6
65	M38100226R	COLT90X12X280DX 50M16 TG	BLAD90X12X280RH 50M16 TG	COUTEAU DC-BR 12MM DRT TUNGSTE	MESSER WOLFRAMCARBID RECHTS DC	
66	M38100227R	COLT90X12X280SX 50M16 TG	BLAD90X12X280LH 50M16 TG	COUTEAU DC-BR 12MM GCH TUNGSTE	MESSER WOLFRAMCARBID LINKS DC	
67	M38100222R	COLT90X14X280DX 50M16	BLAD90X14X280RH 50M16	COUTEAU DROIT DC DS DL 90X14	RECHT MESSER DC DS DL 90X14	CUCHILLO DERECH.DC DS DL 90X14
68	M38100223R	COLT90X14X280SX 50M16	BLAD90X14X280LH 50M16	COUTEAU GAUCHE DC DS DL 90X14	LINKES MESSER DC DS DL 90X14	CUCHILLO IZQ. DC DS DL 90X14

TAV.021

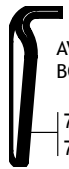

AVVITATO
BOLT-ON

73 - DX/RH
74 - SX/LH

COLTELLO SPESSORE
MAGGIORATO (15 mm)
THICKER BLADE (15 mm)

- 5 - DM-DMR 3000
- 6 - DM-DMR 3500
- 7 - DM-DMR 4000

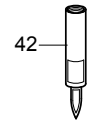

42

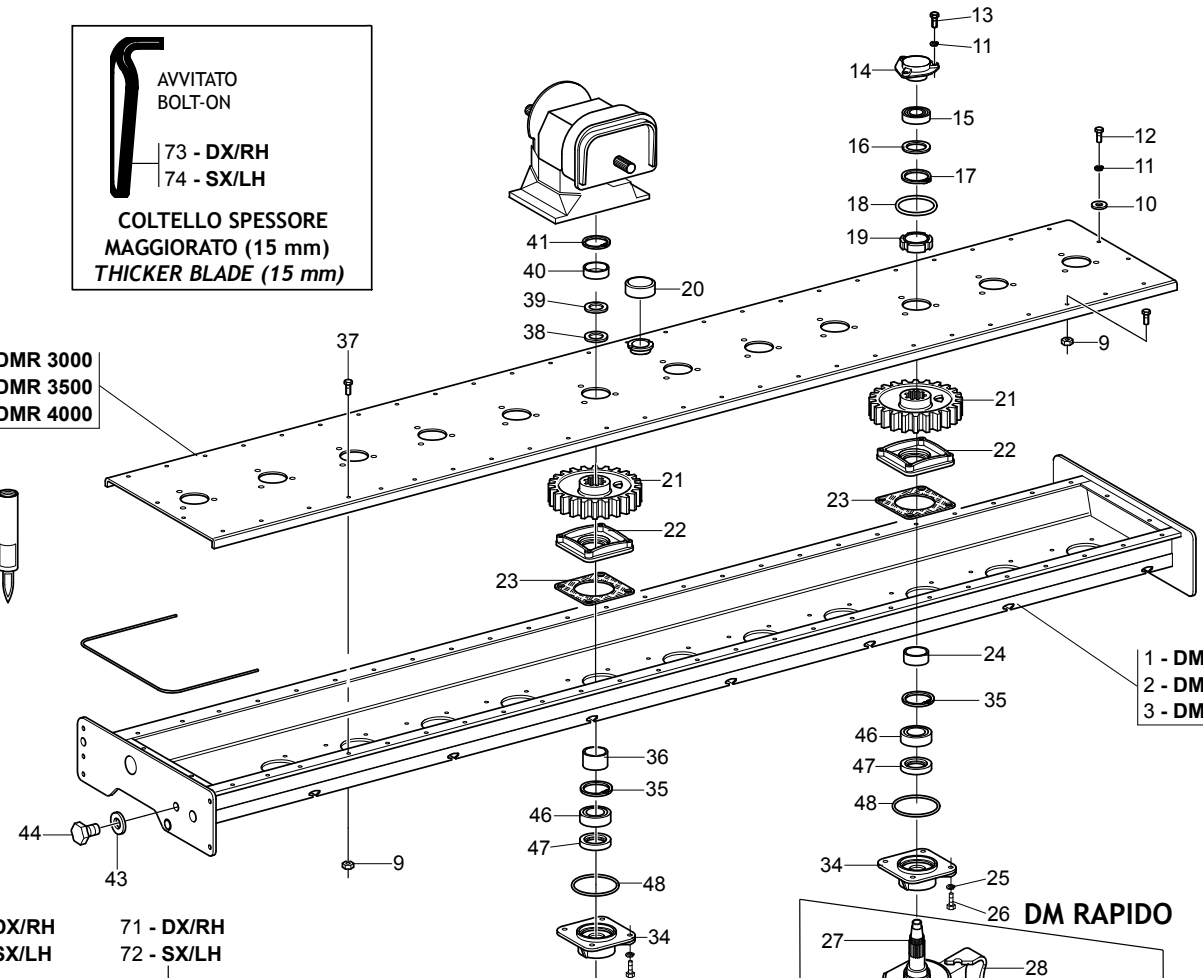

- 69 - DX/RH
- 70 - SX/LH
- 71 - DX/RH
- 72 - SX/LH



AVVITATO
BOLT-ON

COLTELLO IN TUNGSTENO
TUNGSTEN BLADE



SGANCIO
RAPIDO
QUICK FIT

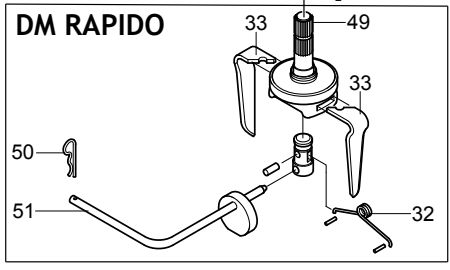

DM RAPIDO

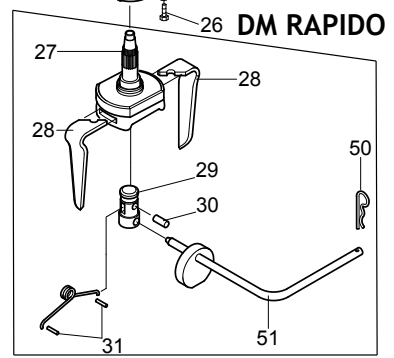

DM RAPIDO

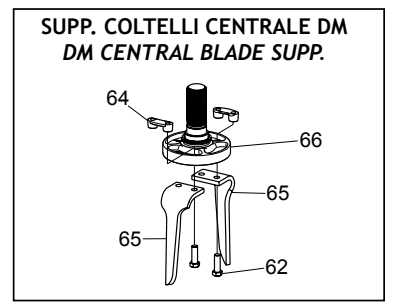

SUPP. COLTELLI CENTRALE DM
DM CENTRAL BLADE SUPP.

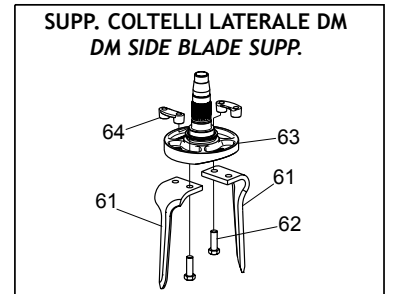

SUPP. COLTELLI LATERALE DM
DM SIDE BLADE SUPP.

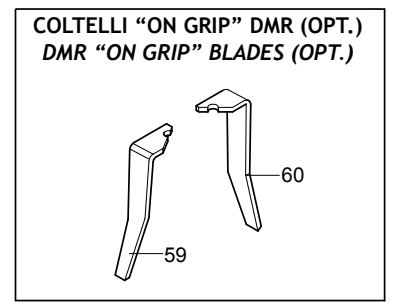

COLTELLI "ON GRIP" DMR (OPT.)
DMR "ON GRIP" BLADES (OPT.)

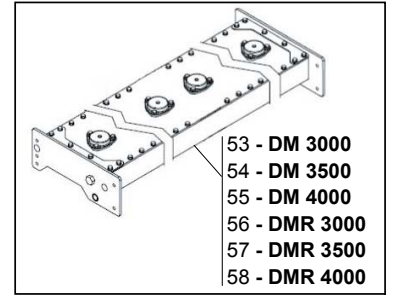

- 53 - DM 3000
- 54 - DM 3500
- 55 - DM 4000
- 56 - DMR 3000
- 57 - DMR 3500
- 58 - DMR 4000

**TELAIO E ROTORI DM - DMR
FRAME AND ROTORS DM - DMR**

TAV.021

Pos.	Cod.	Descrizione	Description	Benennung	Description	Descrpcion
1	M26430582R	COMP.CORPO TRASMISSIONE L=2992	TRANSMISSION BOX L=2992	BOITE DE TRANSMISSION L=2992	ANTRIEBSKASTEN L=2992	CUERPO TRASMISSION L=2992
2	M26435582R	COMP.CORPO TRASMISSIONE L=3484	TRANSMISSION BOX L=3484	BOITE DE TRANSMISSION L=3484	ANTRIEBSKASTEN L=3484	CUERPO TRASMISSION L=3484
3	M26440582R	COMP.CORPO TRASMISSIONE L=3976	TRANSMISSION BOX L=3976	BOITE DE TRANSMISSION L=3976	ANTRIEBSKASTEN L=3976	CUERPO TRASMISSION L=3976
5	M23430510R	COMP.COPERCHIO C.TRASM.L=2954	UPPER PLATE L=2954	CAPOT SUPERIEUR L=2954	OBERBLECH L=2954	PLANCHA SUPERIOR L=2954
6	M23435510R	COMP.COPERCHIO C.TRASM.L=3446	UPPER PLATE L=3446	CAPOT SUPERIEUR L=3446	OBERBLECH L=3446	PLANCHA SUPERIOR L=3446
7	M23440510R	COMP.COPERCHIO C.TRASM.L=3938	UPPER PLATE L=3938	CAPOT SUPERIEUR L=3938	OBERBLECH L=3938	PLANCHA SUPERIOR L=3938
9	F01220034R	DADO M10X1,25	NUT M10X1,25	ECROU M10X1,25	MUTTER M10X1,25	TUER.M10X1,25 D980 8 ZB
10	F01410062R	ROS.M10 10,5X 18X 2	WASHER M10 10,5X 18X 2	RONDELLE M10 10,5X 18X 2	DICHTUNGSRING M10 10,5X18X2 ZN	ARAND.M10 10,5X 18X 2 U6592 ZN
11	F01480112R	ROS.G 10,5X19X 3	GROWER WASHER D.10	GROWER RONDELLE D.10	SCHIEBE GROWER D.10	ARANDELA GROWER D.10
12	F01010244R	VITE M10X1,25X25	SCREW M10X1,25X25	VIS M10X1,25X25	SCHRAUBE M10X1,25X25	TORNILLO M10X1,25X25
13	F20110012R	VITE M10X1,25X 35	SCREW M 10X1,25X35	VIS M 10X1,25X35	SCHRAUBE M 10X1,25X35	TORNILLO M 10X1,25X35
14	M19400303R	SUPPORTO CUSCINETTO SUPER. TN	BEARING SUPPORT	SUPPORT ROULEMENT	LAGERHALTER	SOPORTE COJINETE
15	F04010350R	CUSCINETTO 6307C 2HRS L100 50	BEARING 6307C 2HRS L100 50		LAGER 6307	
16	M19400304R	DISCO ANTICADUTA SFERE	DISCO BALL FALL		SCHIENE	
17	F02050425R	ANELLO E. DI 80X 2,5 U7437 C70	SEEGER RING D.80	BAGUE SEEGER D.80	SEEGERRING D.80	ANELLO E. DI 80X 2,5 U7437 C70
18	F03010684R	ANELLO OR 94,84X3,53 NGR	GASKET OR 94,84X3,53 NGR	BAGUE OR 94,83X3,53 NBR	RING OR 94,84X3,53 NBR	ANILLO OR 94,84X3,53 NBR
19	F02010155R	GHIERA AU.GUP M50X1,5 T.4H ZN	SELF LOCKING NUT M50X1,5	COLLIER AUTOBL. M50X1,5	SELBSTSP. NUTMUTTER M50X1,5	VIROLA AUTOBL. M50X1,5
20	F03150746R	TAPPO CARICO OLIO	OIL INLET CAP	BOUCHON HUILE CHARGEMEN	ENTLUEFTERPFROPFEN	CORCHO OLEO
21	M36100306R	INGRANAGGIO LATERALE DM	GEAR	ENGRENAGE LATERAL DM	ZAHNRAD	ENGRANAJE
22	M19400308R	FLANGIA INTERNA	INNER FLANGE	FLASQUE INTERIEUR	INNENFLANSCH	BRIDA INTERNA
23	M27100309R	GUARNIZIONE FLEXOID 5 10	GASKET MM.0,5	JOINT MM.0,5	DICHTUNG MM.0,5	JUNTA MM.0,5
24	M36100304R	DISTANZIALE ROTORI LATERALI	SPACER		DISTANZSTUECK	
25	F01480123R	ROS.G 12,5X22,9X 4	GROWER WASHER M12 ZGP EXTRA P.	GROVER RONDELLE M12 ZGP EXTRA	UNTERLEGSCHIEBE M12 ZGP EXTRA	ARANDELA M12 ZGP EXTRA P.
26	F01010289R	VITE M12X1,25X35	SCREW M12X1,25X35	VIS M12X1,25X35	SCHRAUBE M12X1,25X35	TORNILLO M12X1,25X35
27	M19400312R	SUPPORTO COLTELLI LATERALE	LATERAL BLADE SUPPORT	SUPPORT COUTEAU LATERAL	SEITLICH MESSERTRAEGER	SOPORTE CUCHILLO LATERAL
28	M36100366R	COLT100X15X320DX QUICK	BLAD100X15X320RH QUICK	COUTEAU RAPIDO 100X15X320 DRT	MESSER QUICK 100X15X320 RECHTS	CUCHILLA DEREK.QUICK-FIT 15MM
29	M36100394R	PERNO D=40 L=76	PIN D=40 L=76	GOUJON D=40 L=76	STIFT D=40 L=76	PERNO D=40 L=76
30	F02100242R	SPINA E.S. 8X 36 U6875 C70 BR	ELASTIC PIN 8X36	GOUJON ELASTIQUE 8X36	SPANNHUELSE 8X36	ESPINA ELASTICA 8X36
31	F02100204R	SPINA E.S. 4X 30 U6875 C70 BR	ELASTIC PIN 4X30			
32	M36100341R	MOLLA X SGANCIO RAPIDO	SPRING QUICK FIT	RESSORT GOUJON RAPIDO	FEDER	MUELLE
33	M36100367R	COLT100X15X320SX QUICK	BLAD100X15X320LH QUICK	COUTEAU RAPIDO 100X15X320 GCH	MESSER QUICK 100X15X320 LINKS	CUCHILLA ISQUIR.QUICK-FIT 15MM
34	M19400307R	FLANGIA SUPP.INFERIORE DM	LOWER FLANGE SUPPORT DM		FLANSCH	
35	F02050471R	ANELLO E. DI100X 3 U7437 C70	SEEGER RING D.100	BAGUE SEEGER D.100	SEEGERRING D.100	ANILLO SEEGER D.100
36	M36500313R	DISTANZ. D=67 D=55 L=16.5	SPACER D=67 D=55 L=16.5	ENTRETOISE D=67 D=55 L=16.5	DISTANZSTUECK D=67 D=55 L=16.5	DISTANCIADOR D=67 D=55 L=16.5
37	F01010254R	VITE M10X1,25X35	SCREW M10X1,25X35	VIS M10X1,25X35	SCHRAUBE M10X1,25X35	TORNILLO M10X1,25X35
38	M36500311R	ROSETTA D=65 D=55 L=0,1	WASHER D=65 D=55 L=0,1	ROSETTE D=65 D=55 L=0,1	SCHIEBE D=65 D=55 L=0,1	ARANDELLA D=65 D=55 L=0,1
39	M36500312R	ROSETTA D=65 D=55 L=0.05	WASHER D=65 D=55 L=0.05	ROSETTE D=65 D=55 L=0.05	SCHIEBE D=65 D=55 L=0.05	ARANDELLA D=65 D=55 L=0.05
40	M36500314R	DISTANZ. D=67 D=55 L=14.8	SPACER D=67 D=55 L=14.8	ENTRETOISE D=67 D=55 L=14.8	DISTANZSTUECK D=67 D=55 L=14.8	DISTANCIADOR D=67 D=55 L=14.8
41	F02050204R	ANELLO E. DE 55X 3 U7436 C70	SEEGER RING D.55	BAGUE SEEGER D.55	SEEGERRING D.55	ANILLO D.55
42	F03220010R	POLIURETANO NERO IN CAR.310 M	SEALING PACKAGE	CONFECTION SIGILLANTE	DICHTUNGSMASSE ANFERTIGUNG	CONFECCION SELADURA
43	M26100321R	GUARNIZIONE PER TAPPO OLIO	GASKET	JOINT	DICHTUNG	JUNTA
44	F03150625R	TAPPO CARICO SCARICO M18X1,5	OIL IN OUT CAP M18X1,5	BOUCHON HUILE CHARGEMEN	ENTLUEFTERPFROPFEN	CORCHO OLEO
46	F04010192R	CUSC.D55 D100 B21 6211 53 KN	BEARING D55 D100 B21 6211 53KN	ROULEMENT 6211 AG15	LAGER 6211 AG15	COJINETE 6211 AG15
47	M38100214R	ANELLO COMBI 65X85X13 17	OIL SEAL 65X85X13 17 SPEC.	PARE-HUILE 65X85X13 17 SPEC	OELABDICHTUNG 65X85X13 17SPEC.	PARA-ACEITE 65X85X13 17 SPEC.
48	F03010726R	ANELLO OR 123.43X3.53 NBR	GASKET OR 123.43X3.53 NBR	BAGUE OR D. 123.43X3.53	RING OR 123.43X3.53 NBR	ANILLO OR 123.43X3.53 NBR
49	M36100229R	SUPPORTO COLTELLI CENTRALE PLS	CENTR. BLADE SUPPORT	SUPPORT COUTEAU CENTRAL DMR	ZENTRALMESSERHALTERUNG	SOPORTE CUCHILLO CENTR.
50	F02200374R	COPIGLIA R 4X 82 ZN	SPRING SPLIT PIN 4X82	GOUPILLE 4X82	SPRINT 4X82	PASADOR 4X82
51	M36100386R	MANICO ECCENTRICO	TOOL FOR QUICK-FIT SYSTEM	MANIVELLE	KURBEL	MANGO
53	M35430520R	CORPO NO CC.DM 3000 COM.RICAMB	COMPLETE BOX DM COMBI 3000	LAMIER COMPL DM COMBI 3000	GEHAEUSE DM COMBI 3000	CUERPO COMPL DM COMBI 3000
54	M35435520R	CORPO NO CC.DM 3500 COM.RICAMB	COMPLETE BOX DM COMBI 3500	LAMIER COMPL DM COMBI 3500	GEHAEUSE DM COMBI 3500	CUERPO COMPL DM COMBI 3500
55	M35440520R	CORPO NO CC.DM 4000 COM.RICAMB	COMPLETE BOX DM COMBI 4000	LAMIER COMPL DM COMBI 4000	GEHAEUSE DM COMBI 4000	CUERPO COMPL DM COMBI 4000
56	M23430599R	CORPO TR. DMR3000 STD-COMBI 08	TRANSM.BOX DMR3000 STD-COMBI08		GEHAEUSE DMR COMBI 3000	
57	M23435599R	CORPO TR. DMR3500 STD-COMBI 08	TRANSM.BOX DMR3500 STD-COMBI08			
58	M23440599R	CORPO TR. DMR4000 STD-COMBI 08	TRANSM.BOX DMR4000 STD-COMBI08			
59	M36100228R	COLT100X15X330SX QUICK OG	BLAD100X15X330LH QUICK OG	COUTEAU RAPIDO ONGRIP 15MM GCH	LINKS 15MM AUF GRIFF ZINKEN	CUCHILLA ON GRIP 15MM IZQUIER.
60	M36100227R	COLT100X15X330DX QUICK OG	BLAD100X15X330RH QUICK OG	COUTEAU RAPIDO ONGRIP 15MM DRT	RECHTS 15MM AUF GRIFF ZINKEN	CUCHILLA ON GRIP 15MM DERECHA

TAV.021

AVVITATO
BOLT-ON

73 - DX/RH
74 - SX/LH

COLTELLO SPESSORE
MAGGIORATO (15 mm)
THICKER BLADE (15 mm)

- 5 - DM-DMR 3000
- 6 - DM-DMR 3500
- 7 - DM-DMR 4000

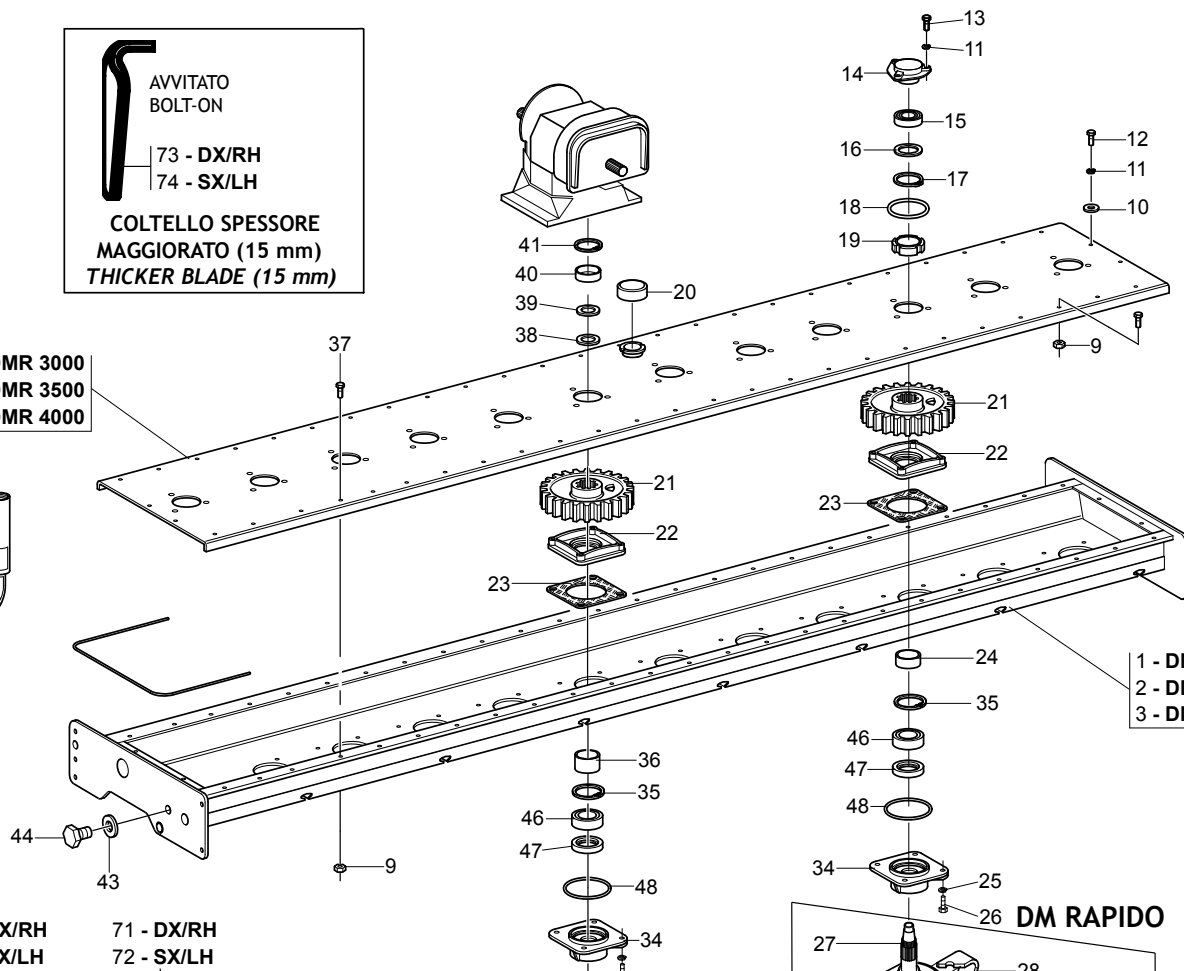
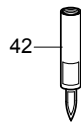

- 1 - DM-DMR 3000
- 2 - DM-DMR 3500
- 3 - DM-DMR 4000

- 69 - DX/RH
- 70 - SX/LH
- 71 - DX/RH
- 72 - SX/LH

AVVITATO
BOLT-ON

SGANCIO
RAPIDO
QUICK FIT

COLTELLO IN TUNGSTENO
TUNGSTEN BLADE

DM RAPIDO

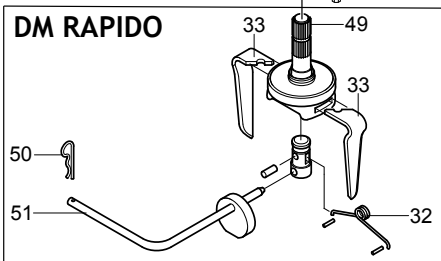

DM RAPIDO

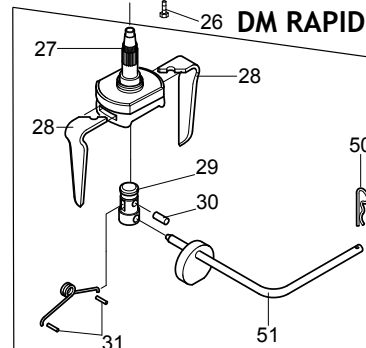

SUPP. COLTELLI CENTRALE DM DM CENTRAL BLADE SUPP.

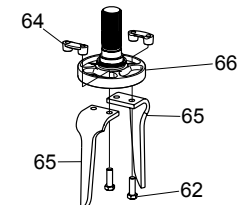

SUPP. COLTELLI LATERALE DM DM SIDE BLADE SUPP.

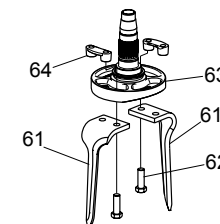

COLTELLI "ON GRIP" DMR (OPT.) DMR "ON GRIP" BLADES (OPT.)

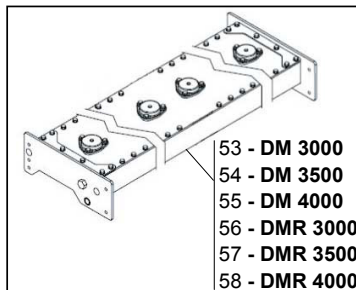
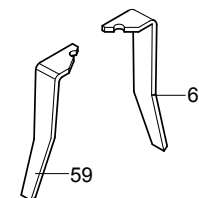

- 53 - DM 3000
- 54 - DM 3500
- 55 - DM 4000
- 56 - DMR 3000
- 57 - DMR 3500
- 58 - DMR 4000

**TELAIO E ROTORI DM - DMR
FRAME AND ROTORS DM - DMR**

TAV.021

Pos.	Cod.	Descrizione	Description	Benennung	Description	Description
61	M36100210R	COLT100X12X300DX 60M16	BLAD100X12X300RH 60M16	COUTEAUX DM 100X12 DROIT	RECHTES MESSER 100X12	CUCHILLO DERECHO 100X12
62	F20110044R	VITE M16X1,5X50	SCREW M16X1,5X50	VIS M16X1,5X50	SCHRAUBE M16X1,5X50	TORNILLO M16X1,5X50
63	M36100332R	SUPPORTO COLTELLI LATERALE	LATERAL BLADE SUPPORT	SUPPORT COUTEAU LATERAL	SEITLICH MESSERTRAEGER	SOPORTE CUCHILLO LATERAL
64	M36100312R	FERMO VITE COLTELLI	KNIVES FASTENING BOLT	ETRIER DE SERRAGE COUTEAUX DM	MESSERSCHRAUBESPERRUNG	CLAUSURA TORNILLO CUCHILLA
65	M36100211R	COLT100X12X300SX 60M16	BLAD100X12X300LH 60M16	COUTEAUX DM 100X12 GAUCHE	LINKES MESSER 100X12	CUCHILLO IZQUIERDO
66	M19400302R	SUPPORTO COLTELLI CENTRALE	CENTRAL BALDE SUPPORT		ZENTR. MESSERHALTERUNG	
69	M36100223R	COLT100X12X306DX 60M16 TG	BLAD100X12X306RH 60M16 TG	COUTEAU DM 12MM TUNGSTENE DRT		
70	M36100224R	COLT100X12X306SX 60M16 TG	BLAD100X12X306LH 60M16 TG	COUTEAU DM 12MM TUNGSTENE GCH		
71	M36100285R	COLT100X15X320DX QUICK TG	BLAD100X15X320RH QUICK TG	COUTEAU DRT QUICK100X15X320TUN	RECHTS MESSER 100X15X320 TUNGS	CUCHILLA DER.QUICK-FIT TUNGST.
72	M36100286R	COLT100X15X320SX QUICK TG	BLAD100X15X320LH QUICK TG	COUTEAU GCH QUICK100X15X320TUN	LINKES MESSER 100X15X320 TUNGS	CUCHILLA IZ.QUICK-FIT TUNGST.
73	M36100215R	COLT100X15X300DX 60M16	BLAD100X15X300RH 60M16	COUTEAU DRT SP.15 DM	RECHTES MESSER DM - 15 MM	
74	M36100216R	COLT100X15X300SX 60M16	BLAD100X15X300LH 60M16	COUTEAU GCH. SP.15 DM	LINKES MESSER DM 15 MM	

TAV.031

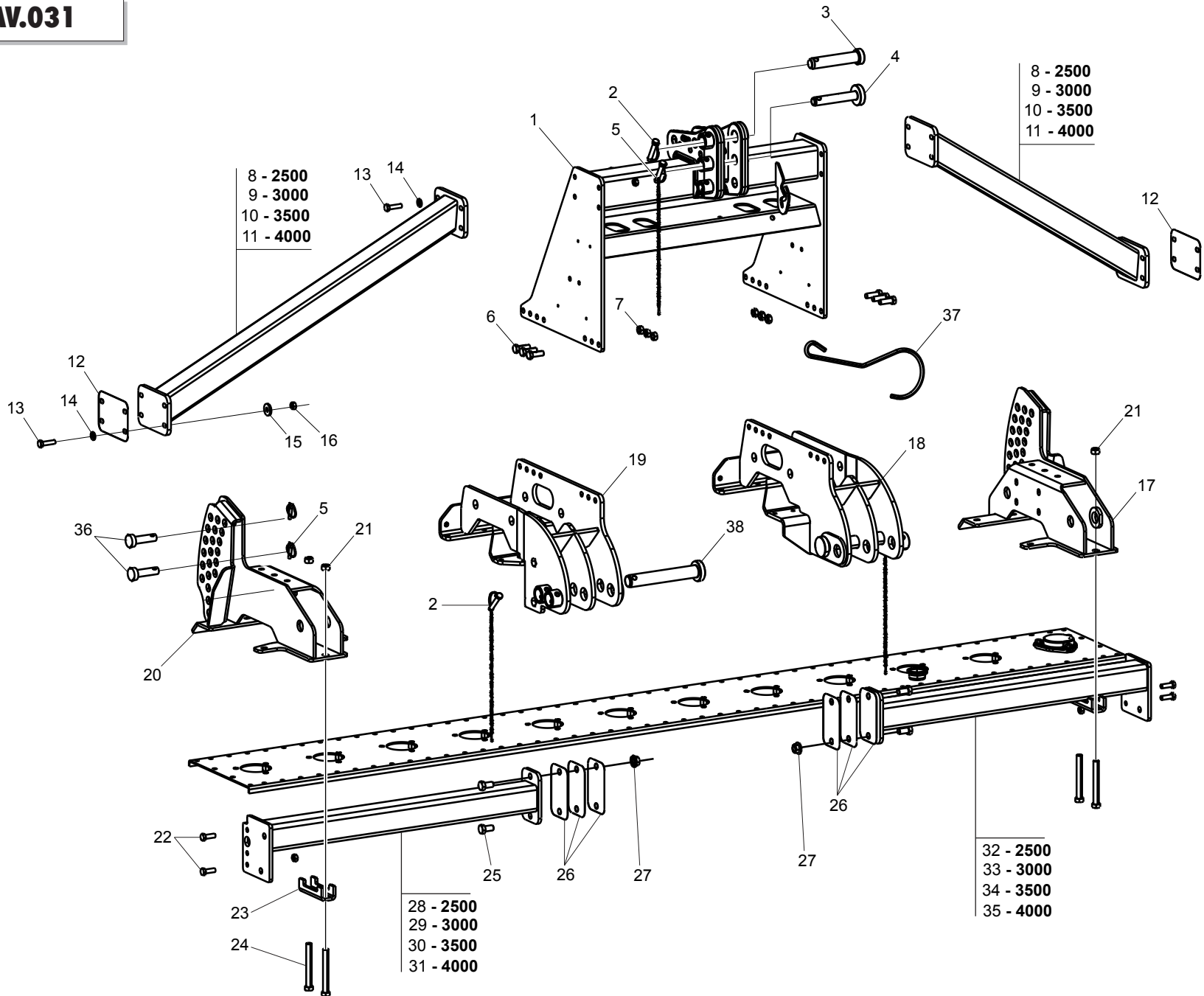

**GRUPPO TERZO PUNTO COMBI
3RD-POINT UNIT COMBI**

TAV.031

Pos.	Cod.	Descrizione	Description	Benennung	Description	Descrpcion
1	M52400550R	CASTELLO 3 PUNTO	COMPLETE 3RD POINT			
2	F02200584R	SPINA SICUR.D.12X70 ZN	PIN D12 L70 ZN	FICHE D12 L70 ZN	STIFT D12 L70 ZN	CLAVIJA D12 L70 ZN
3	F20100124R	PERNO D32 L135 C40 TEST.D45 Z	BOLT D32 L135 C40 ZN	BOULON D32 L135 C40 ZN	BOLZEN D32 L135 C40 ZN	PERNO D32 L135 C40 ZN
4	F20100133R	PERNO D25 L122 C43 TEST.D60 ZN	PIN D25 L122 C43 ZN	BOULON D25 L122 C43 ZN	BOLZEN D25 L122 C43 ZN	PERNO D25 L122 C43 ZN
5	F02200529R	SPINA SCATTO D.11 H58 ZN	SNAP PIN D.11 H58 ZN	FICHE A DETENTE D.11 H58 ZN	EINRASTSTIFT D.11 H58 ZN	CLAVIJA DE MUELLE D.11 H58 ZN
6	F20110032R	VITE M14X1,5 X 40	SCREW M14X 1,5X 40	VIS M14X 1,5X 40	SCHRAUBE M14X 1,5X 40	TORNILLO M14X 1,5X 40
7	F01220059R	DADO M14X1,5	NUT M14X1,5	ECROU M14X1,5	MUTTER M14X1,5	TUERCA M14X 1,5 D980 8 ZN
8	M26425598R	COLLEGAMENTO 3 P. DC-DM 2500	RIGHT 3POINT LINKAGE BEAM 2500	POUTRE ATT.3 POINT.DROITE 2500	RECHTS 3 PUNKTBOCK STREBUNG	TIRANTE ENGANCHE 3P.DERECHO
9	M26430598R	COLLEGAMENTO 3 P. DC-DM 3000	RIGHT 3POINT LINKAGE BEAM 3000	POUTRE ATT.3 POINT.DROITE 3000	RECHTS 3 PUNKTBOCK STREBUNG	TIRANTE ENGANCHE 3P.DERECHO
10	M26435598R	COLLEGAMENTO 3 P. DC-DM 3500	RIGHT 3POINT LINKAGE BEAM 3500	POUTRE ATT.3 POINT.DROITE 3500	RECHTS 3 PUNKTBOCK STREBUNG	TIRANTE ENGANCHE 3P.DERECHO
11	M26440598R	COLLEGAMENTO 3 P. DC-DM 4000	RIGHT 3POINT LINKAGE BEAM 4000	POUTRE ATT.3 POINT.DROITE 4000	RECHTS 3 PUNKTBOCK STREBUNG	TIRANTE ENGANCHE 3P.DERECHO
12	M26400597R	PIATTO	PLATE		PLATTE	
13	F01010053R	VITE M12X1,25X45	SCREW M12X1,25X45	VIS M12X1,25X45	SCHRAUBE M12X1,25X45	TORNILLO M12X1,25X45
14	F01410076R	ROS.M1213X24X2,5	WASHER 12 13X 24X2,5	RONDELLE 12 13X 24X2,5	SCHEIBE M12 13X24X2,5 U6592 ZN	ARAND.M12 13X 24X2,5 U6592 ZN
15	F01500011R	RONDELLA 13X35X5	WASHER D. 12	RONDELLE D. 12	SCHEIBE D.12	ARANDELA D.12
16	F01220047R	DADO M12X1,25	NUT M12X1,25	ECROU M12X1,25	MUTTER M12X1,25	TUERCA M12X1,25 D980 8 ZN
17	M26400732R	SUPPORTO SX REGOLAZIONE RULLO	LEFT SUPPORT	SUPPORT GAUCHE	LINK TRAEGER	SOPORTE ISQUIERDO
18	M35400705R	BASE 3 PUNTO SX 2-3 CAT	LEFT BASE 3 POINT 2-3 CAT			
19	M35400706R	BASE 3 PUNTO DX 2-3 CAT	RIGHT BASE 3 POINT 2-3 CAT			
20	M26400731R	SUPPORTO DX REGOLAZIONE RULLO	RIGHT SUPPORT	SUPPORT DROIT	RECHTE TRAEGER	SOPORTE DERECHO
21	F01220070R	DADO M16X1,5	NUT M16X1,5	ECROU M16X1,5	MUTTER M16X1,5	TUER.M16X1,5 D980 8ZN
22	F01010288R	VITE M12X1,25X35	SCREW M12X1,25X35	VIS M12X1,25X35	SCHRAUBE M12X1,25X35	TORNILLO M12X1,25X35
23	M36200241R	STAFFA PER TUBO DA 80	STIRRUP	ETRIER	BUEGEL	ESTRIBO
24	F01010128R	VITE M16X1,5X130	SCREW M16X1,5X130	VIS M16X1,5X130	SCHRAUBE M16X1,5X130	TORNILLO M16X1,5X130
25	F01020562R	VITE M16X2X30	SCREW M16X2X30	VIS M16X2X30	SCHRAUBE M16X2X30	TORNILLO M16X2X30
26	M35400774R	DISTANZIALE PER TRAVE	SPACER FOR BEAM			
27	F01260071R	DADO M16X2	NUT M16X2	ECROU M16X2	MUTTER M16X2 D6923 8.8GE	
28	M35425734R	TRAVE ANTERIORE DX 80X80 2500	RIGHT FRONT BEAM 80X80 2500			
29	M35430734R	TRAVE ANTERIORE DX 80X80 3000	FRONT BEAM RIGHT 80X80 3000			
30	M35435734R	TRAVE ANTERIORE DX 80X80 3500	FRONT BEAM RIGHT 80X80 3500			
31	M35440734R	TRAVE ANTERIORE DX 80X80 4000	FRONT BEAM RIGHT 80X80 4000			
32	M35425735R	TRAVE ANTERIORE SX 80X80 2500	LEFT FRONT BEAM 80X80 2500			
33	M35430735R	TRAVE ANTERIORE SX 80X80 3000	FRONT BEAM LEFT 80X80 3000			
34	M35435735R	TRAVE ANTERIORE SX 80X80 3500	FRONT BEAM LEFT 80X80 3500			
35	M35440735R	TRAVE ANTERIORE SX 80X80 4000	FRONT BEAM LEFT 80X80 4000			
36	F20100048R	PERNO D22 L48 C43 TEST.D35 ZN	BOLT D22 L48 C43 ZN	GOUJON D22 L48 C43	BOLZEN D22 L48 C43	PERNO D22 L48 C43
37	F20120400R	GANCIO SOSTEGNO CARDANO	SHAFT HOOK SUPPORT	SUPPORT CARDAN	GELENKWELLE - HACKEN	SOPORTE CARDAN
38	F20100142R	PERNO D36 L208 C43 TEST.D60 ZN	PIN D36 L208 C43 ZN	GOUJON D36 L208 C43 ZN	BOLZEN D36 L208 C43 ZN	PERNO D36 L208 C43 ZN

TAV.040

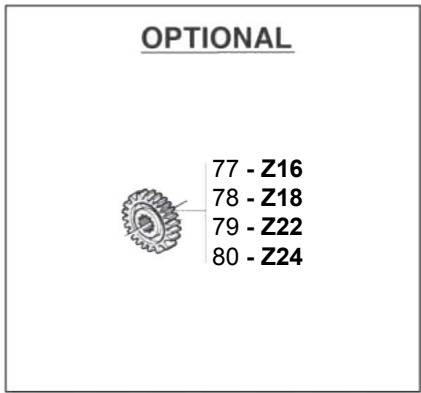
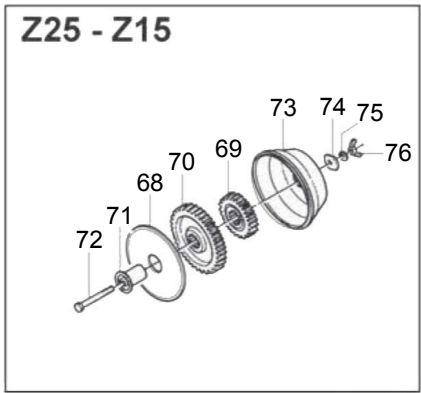
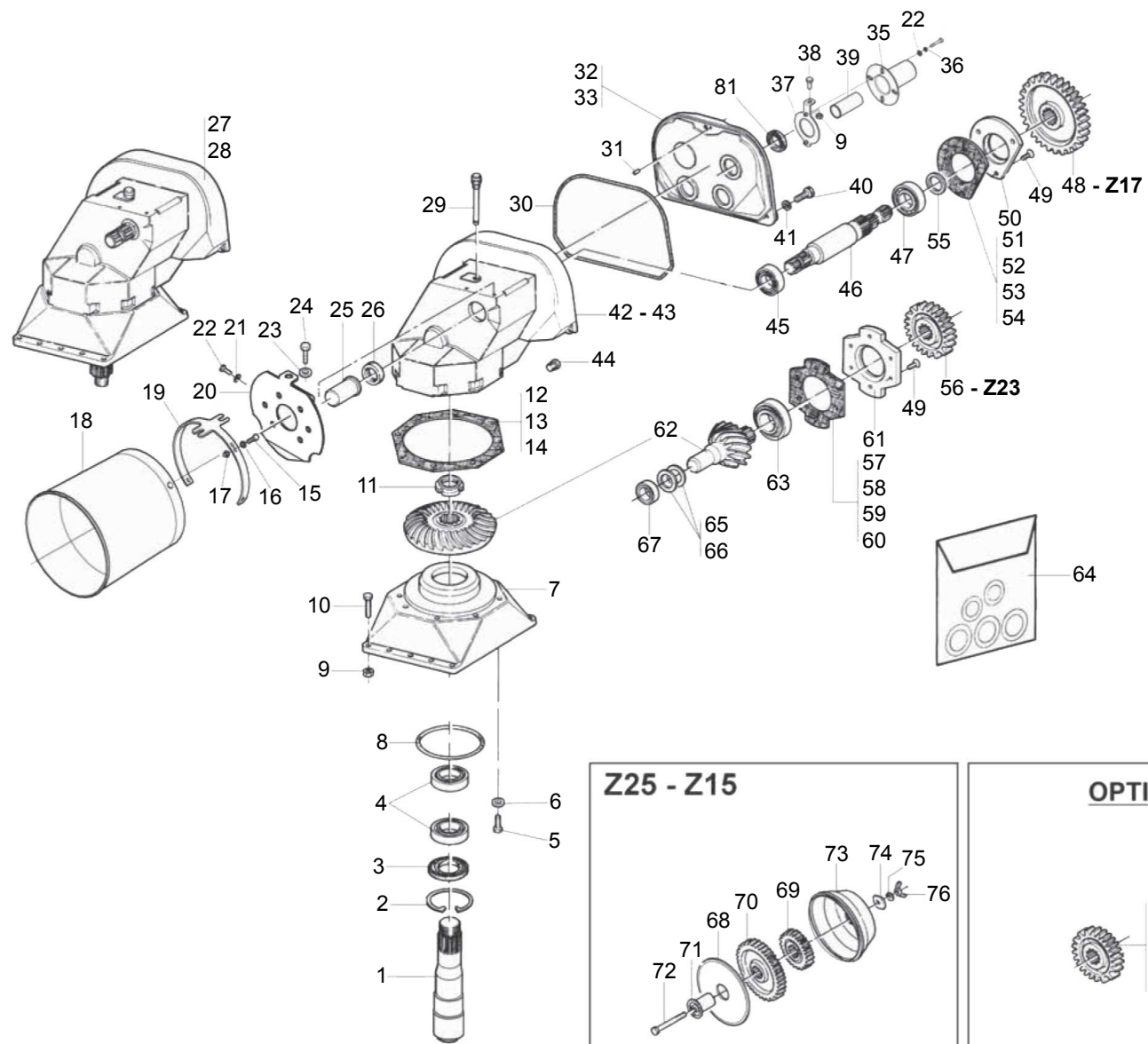

**GRUPPO CAMBIO
GEARBOX**

TAV.040

Pos.	Cod.	Descrizione	Description	Benennung	Description	Descrpcion
1	M19400203R	ALBERO TRASM.D=80 L=208,5	SHAFT TR.D=80 L=208,5		ANTRIEBSWELLE	
2	F02050482R	ANELLO E. DI110X 4 U7437 C70	SEEGER RING D.110	BAGUE SEEGER D.110	SEEGERRING D.110	ANILLO SEEGER D.110
3	F03010244R	ANELLO T.A. 80X110X10 D3760NBR	OIL SEAL 80X110X10	PARE-HUILLE 80X110X10	OELABDICHTUNG 80X110X10	PARA-ACEITE 80X110X10
4	F04050117R	CUSC.D65 D110 T34 33113	BEARING D65 D110 T34 33113	ROULEMENT D65 D110 T34 33113	LAGER D65 D110 T34 33113	COJINETE D65 D110 T34 33113
5	F01010289R	VITE M12X1,25X35	SCREW M12X1,25X35	VIS M12X1,25X35	SCHRAUBE M12X1,25X35	TORNILLO M12X1,25X35
6	F01480123R	ROS.G 12,5X22,9X 4	GROVER RONDELLE M12 ZGP EXTRA P.	GROVER WASHER M12 ZGP EXTRA	UNTERLEGSCHLEIBE M12 ZGP EXTRA	ARANDELA M12 ZGP EXTRA P.
7	M19400202R	BASE CAMBIO	GEARBOX SUPPORT	SUPPORT BOITE DE VITESSE	WECHSELGETRIEBE HALTER	SOPORTE CAMBIO
8	F03010738R	ANELLO OR 126,59X353 NBR	GASKET OR 126,59X353 NBR	BAGUE OR	RING OR	ANILLO OR
9	F01220034R	DADO M10X1,25	NUT M10X1,25	ECROU M10X1,25	MUTTER M10X1,25	TUER.M10X1,25 D980 8 ZB
10	F01010254R	VITE M10X1,25X35	SCREW M10X1,25X35	VIS M10X1,25X35	SCHRAUBE M10X1,25X35	TORNILLO M10X1,25X35
11	F02010155R	GHIERA AU.GUP M50X1,5 T.4H ZN	SELF LOCKING NUT M50X1,5	COLLIER AUTOBL. M50X1,5	SELBSTSP. NUTMUTTER M50X1,5	VIOLA AUTOBL. M50X1,5
12	M14100204R	GUARNIZIONE FLANGIA PR 1 10	GASKET MM.0,1	JOINT MM.0,1	DICHTUNG MM.0,1	JUNTA MM.0,1
13	M14100205R	GUARNIZIONE FLANGIA PR 3 10	GASKET MM.0,3	JOINT MM.0,3	DICHTUNG MM.0,3	JUNTA MM.0,3
14	M14100206R	GUARNIZIONE FLANGIA PR 5 10	GASKET MM.0,5	JOINT MM.0,5	DICHTUNG MM.0,5	JUNTA MM.0,5
15	F01020403R	VITE M6X1X16	SCREW M6X1X16	VIS M6X1X16	SCHRAUBE M6X1X16	TORNILLO M6X1X16
16	F01410037R	ROS.M6 6,4X12,5X1,6	WASHER M6 6,4X12,5X1,6	RONDELLE M6 6,4X12,5X1,6	SCHLEIB.M6 6,4X12,5X1,6 U6592ZN	ARAND.M6 6,4X12,5X1,6 U6592 ZN
17	F01220011R	DADO M6X1	NUT M6X1	ECROU M6X1	MUTTER M6X1	TUERCA M6X1 D980 8 ZN
18	M68100106R	PROTEZIONE CARDANO	CARDAN PROTECTION	PROTECTION CARDAN	GELENKWELLENSCHUTZ	PROTECCION CARDANICO
19	M12400115R	ATTACCO CUFFIA	PROTECTION SUPPORT	SUPPORT PROTECTION CARDAN	GELENKWELLENSCHUTZ HALTER	SOPORTE PROTECCION CARDANICO
20	M12400111R	ATTACCO CUFFIA	PROTECTION SUPPORT	SUPPORT PROTECTION CARDAN	GELENKWELLENSCHUTZ HALTER	SOPORTE PROTECCION CARDANICO
21	F01410037R	ROS.M6 6,4X12,5X1,6	WASHER M6 6,4X12,5X1,6	RONDELLE M6 6,4X12,5X1,6	SCHLEIB.M6 6,4X12,5X1,6 U6592ZN	ARAND.M6 6,4X12,5X1,6 U6592 ZN
22	F01020403R	VITE M6X1X16	SCREW M6X1X16	VIS M6X1X16	SCHRAUBE M6X1X16	TORNILLO M6X1X16
23	F01480099R	ROS.G 8,4X14,4X2,7	GROWER WASHER D.8	GROWER RONDELLE D.8	SCHLEIBE GROWER D.8	ARANDELA GROWER D.8
24	F01020436R	VITE M8X1,25X20	SCREW M8X1,25X20	VIS M8X1,25X20	SCHRAUBE M8X1,25X20	TORNILLO M8X1,25X20
25	M38100147R	MANICOTTO PROTEZIONE PDF 1 3 4	P.T.O. PROTECTION	MANCHON DE PROTECTION P.T.O.	ZAPFWELLENSCHUTZ P.T.O.	MANGUITO PROTECCION P.T.O.
26	F03010286R	ANEL. T.AS 45X 60X 7 D3760NBR	OIL SEAL 45X60X7	PARE-HUILLE 45X 60X 7 D3760NBR	OELABDICHTUNG 45X 60X 7	PARA-ACEITE 45X 60X 7 D3760NBR
27	M19400101R	COMP.M.CAM.C.DM 2500 3500 4500	GEAR BOX ASSEMBLY 2500-4500	BOITE DE VITESSE 2500-4500	WECHSELGETR.KOMPL.2500-4500	CAJA CAMBIO COMPL.2500-4500
28	M19400102R	COMP.M.CAM.C.DM 3000 4000 5000	GEAR BOX ASSEMBLY 3000-5000	BOITE DE VITESSE 3000-5000	WECHSELGETR.KOMPL.3000-5000	CAJA CAMBIO COMPL.3000-5000
29	M36100123R	TAPPO SFIATO CON ASTINA DM	BREATHER PLUG	BOUCHON DE SOUPIRAIL	ENTLUEFTERSTOPFEN	TAPON RESPIRADERO
30	M38100105R	GUARNIZIONE COPERCHIO CAMBIO	GEARBOX COVER GASKET	JOINT COUVERCLE BOITE DE VIT.	WECHSELGETRIEBEDECKEL DICHTUNG	JUNTA TAPA CAMBIO
31	F02100292R	SPINA CIL. 6X 20 U2338 1999	PIN		BOLZEN	
32	M36100151R	COPERCHIO CAMBIO	COVER GEAR	COUVERCLE BOITE DE VITESSE	WECHSELGETRIEBEDECKEL	TAPA CAMBIO
33	M36100152R	COPERCHIO CAMBIO	GEARBOX COVER	COUVERCLE BOITE DE VIT.	WECHSELGETRIEBEDECKEL	TAPA CAMBIO
35	F01410051R	ROS.M8 8,4X 17X1,6	WASHER M8 8,4X17X1,6	RONDELLE M8 8,4X17X1,6	SCHLEIBE M8 8,4X17X1,6 U6592 ZN	ARAND.M8 8,4X 17X1,6 U6592 ZN
36	F01480088R	ROS.G 6,4X12,4X2	GROWER WASHER D.6	GROWER RONDELLE D.6	SCHLEIBE GROWER D.6	ARANDELA GROWER D.6
37	M19400103R	COMP. SUPPORTO PDF POSTERIORE	REAR GUARD SUPPORT	SUPPORT PROTECTION ARRI RE	HINTERE SHUTZUNGHALTER	SOPORTE PROTECCION POSTERIOR
38	F01010244R	VITE M10X1,25X25	SCREW M10X1,25X25	VIS M10X1,25X25	SCHRAUBE M10X1,25X25	TORNILLO M10X1,25X25
39	F20150001R	PROTEZIONE P.F.P.1 3 4 GRUPPO	PROTECTION	CARTER	SCHUTZ	PROTECCION
40	F01020476R	VITE M10X1,5X30	SCREW M10X1,5X30	VIS M10X1,5X30	SCHRAUBE M10X1,5X30	TORNILLO M10X1,5X30
41	F01410062R	ROS.M10 10,5X 18X 2	WASHER M10 10,5X 18X 2	RONDELLE M10 10,5X 18X 2	DICHTUNGSRING M10 10,5X18X2 ZN	ARAND.M10 10,5X 18X 2 U6592 ZN
42	M36100101R	CORPO RID.CAMBIO 3000 4000	GEARBOX 3000 4000 5000	BOITE DE VITESSE 3000 4000 500	WECHSELGETRIEBEGEHAEUSE	CAJA CAMBIO 3000 4000 5000
43	M36100104R	CORPO RID.CAMBIO DM 3500 4500	GEARBOX 3500 4500	BOITE DE VITESSE 3500 4500	WECHSELGETRIEBEGEHAEUSE	CAJA CAMBIO 3500 4500
44	F03150630R	TAPPO SCARICO 1 2 GAS CON.	OIL OUTLET PLUG 1 2	BOUCHON DE VIDANGE HUILE 1 2	OELABLASSPFROPFEN 1 2	TAPON DESCARGADO ACEITE 1 2
45	F04050018R	CUSC. D45 D85 T20,75 30209	BEARING D45 D85 T20,75 30209	ROULEMENT D45 D85 T20,75 30209	LAGER D45 D85 T20,75 30209	COJINETE D45 D85 T20,75 30209
46	M36100150R	ALBERO PRESA DI FORZA	POWER TAKE-OFF SHAFT	ARBRE PRISE DE FORCE	ZAPFWELLE P.D.F.	ARBOL TOMA DE FUERZA
47	F04050041R	CUSC. D45 D100 T27,25 30309	BEARING D45 D100 T27,25 30309	ROULEMENT D45 D100 T27,25 3030	LAGER D45 D100 T27,25 30309	COJINETE D45 D100 T27,25 30309
48	M24100109R	INGRAN. CAMBIO Z 17 M7	GEAR Z-17	ENGRENAGE Z-17	ZAHNRAD WECHSELGETRIEBE Z-17	ENGRANAJE Z-17
49	F01030085R	VITE M10X1,5X25	SCREW M10X1,5X25	VIS M10X1,5X25	SCHRAUBE M10X1,5X25	TORNILLO M10X1,5X25
50	M36100138R	FLANGIA CUSC. ALBERO PDF	BEARING SUPPORT	SUPPORT ROULEMENT	LAGERHALTER	SOPORTE COJINETE
51	M36100111R	GUARNIZ.FL.P.F.MYLARE 0,05 DM	GASKET MM. 0,05	JOINT MM.0,05	DICHTUNG MM.0,05	JUNTA MM.0,05
52	M36100112R	GUARN.FL.CUSC.P.F.PRESPAN 0,1	GASKET MM.0,1	JOINT MM.0,1	DICHTUNG MM.0,1	JUNTA MM.0,1
53	M36100113R	GUARN.FL.CUSC.P.F.PRESPAN 0,3	GASKET MM.0,3	JOINT MM.0,3	DICHTUNG MM.0,3	JUNTA MM.0,3
54	M36100114R	GUARN.FL.CUSC.P.F.PRESPAN 0,5	GASKET MM.0,5	JOINT MM.0,5	DICHTUNG MM.0,5	JUNTA MM.0,5
55	M36100149R	DISTANZIALE INGR.	SPACER	ENTRETOISE	ENTRETSUECK	DISTANCIADOR
56	M24100110R	INGRAN. CAMBIO Z 23 M7	GEAR Z-23	ENGRENAGE Z-23	ZAHNRAD WECHSELGETRIEBE Z-23	ENGRANAJE Z-23
57	M36100133R	GUA.FLAN.CUS.PIG.MYLAR 0,05 DM	GASKET MM. 0,05	JOINT MM.0,05	DICHTUNG MM.0,05	JUNTA MM.0,05

TAV.040

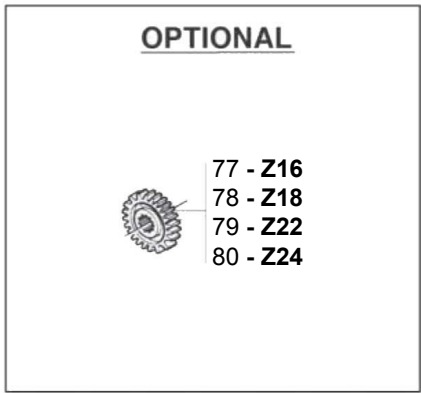
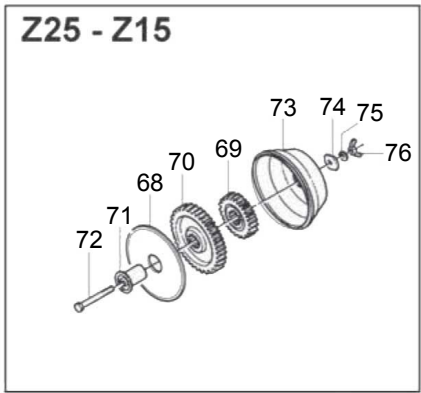
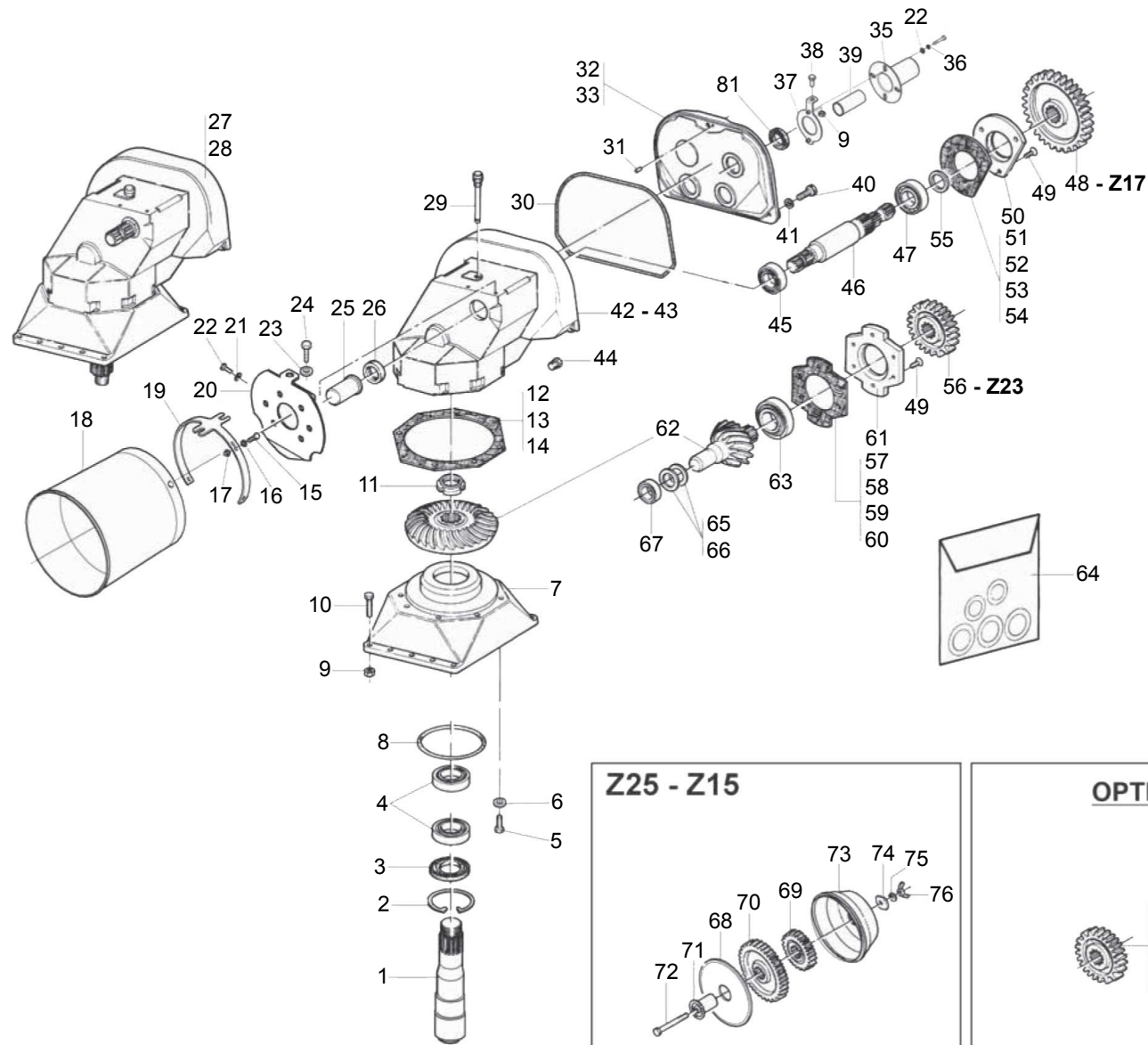

**GRUPPO CAMBIO
GEARBOX**

TAV.040

Pos.	Cod.	Descrizione	Description	Benennung	Description	Description
58	M36100134R	GUA.FLA.CUS.PIG.PRESPAN 0,1 DM	GASKET MM.0,1	JOINT MM.0,1	DICHTUNG MM.0,1	JUNTA MM.0,1
59	M36100135R	GUA.FLA.CUS.PIG.PRESPAN 0,3 DM	GASKET MM.0,3	JOINT MM.0,3	DICHTUNG MM.0,3	JUNTA MM.0,3
60	M36100136R	GUA.FLA.CUS.PIG.PRESPAN 0,5 DM	GASKET MM.0,5	JOINT MM.0,5	DICHTUNG MM.0,5	JUNTA MM.0,5
61	M36100132R	FLANGIA CUSCINETTO PIGNONE	BEARING SUPPORT FLANGE PINION	FLASQUE ROULEMENT	LAGERFLANSCH	BRIDA COJINETE
62	M36100153R	COPPIA CONICA	BEVEL GEAR PAIR	COUPLE CONIQUE	KEGELRITZELSATZ	PAR CONICO
63	F04050118R	CUSC. D65 D120 T41 33213	BEARING D65 D120 T41 33213	ROULEMENT D65 D120 T41 33213	LAGER D65 D120 T41 33213	COJINETE D65 D120 T41 33213
64	F03100072R	SERIE GUARNIZIONI CAMBIO DM	GASKET SET DM	SERIE JOINTS DM	DICHTUNGSSATZ DM	SERIE JUNTAS DM
65	M36200132R	SPESSORE REGISTRO 0,15	SPACER MM.0,15	ENTRETOISE MM.0,15	DISTANZSTUECK MM.0,15	DISTANCIADOR MM.0,15
66	M36200133R	SPESSORE REGISTRO 0,30	SPACER MM.0,3	EPAISSEUR MM.0,3	PLAETTCHEN MM.0,3	ESPESOR MM.0,3
67	F04050036R	CUSC.D20 D52 T16,25 30304	BEARING D20 D52 T13,25 30304	ROULEMENT D20 D52 T13,25 30304	LAGER D20 D52 T13,25 30304	COJINETE D20 D52 T13,25 30304
68	M12400126R	COPERCHIO	GEAR CONTAINER COVER	COUVERCLE	DECKEL	TAPA
69	M24100116R	INGRANAGGIO Z=15	GEAR Z-15	ENGRENAGE Z-15	ZAHNRAD WECHSELGETRIEBE Z-15	ENGRANAJE Z-15
70	M24100117R	INGRANAGGIO Z=25	GEAR Z-25	ENGRENAGE Z-25	ZAHNRAD WECHSELGETRIEBE Z-25	ENGRANAJE Z-25
71	M36100592R	SUPPORTO CON BASE	SPACER	ENTRETOISE	DISTANZSTUECK	DISTANCIADOR
72	F01010065R	VITE M12X1,25X110	SCREW M12X1,25X110	VIS M12X1,25X110	SCHRAUBE M12X1,25X110	TORNILLO M12X1,25X110
73	M36100590R	COPERCHIO CONTENITORE INGR.	COVER	COUVERCLE	DECKEL	TAPA
74	F01410100R	ROS.M16 17X30X 3	WASHER M16 17X30X3	RONDELLE M16 17X30X3	SCHRAUBE M16 17X 30X3 U6592 ZN	ARAND.M16 17X 30X 3 U6592 ZN
75	F01480123R	ROS.G 12,5X22,9X 4	GROVER WASHER M12 ZGP EXTRA P.	GROVER RONDELLE M12 ZGP EXTRA	UNTERLEGSCHLEIBE M12 ZGP EXTRA	ARANDELA M12 ZGP EXTRA P.
76	F01220047R	DADO M12X1,25	NUT M12X1,25	ECROU M12X1,25	MUTTER M12X1,25	TUERCA M12X1,25 D980 8 ZN
77	M24100113R	INGR.PER CAMBIO M7 Z=16	GEAR Z-16	ENGRENAGE Z-16	ZAHNRAD WECHSELGETRIEBE Z-16	ENGRANAJE Z-16
78	M24100111R	INGRAN. CAMBIO Z 18 M7	GEAR Z-18	ENGRENAGE Z-18	ZAHNRAD WECHSELGETRIEBE Z-18	ENGRANAJE Z-18
79	M24100112R	INGRAN. CAMBIO Z 22 M7	GEAR Z-22	ENGRENAGE Z-22	ZAHNRAD WECHSELGETRIEBE Z-22	ENGRANAJE Z-22
80	M24100114R	INGR.PER CAMBIO M7 Z=24	GEAR Z-24	ENGRENAGE Z-24	ZAHNRAD WECHSELGETRIEBE Z-24	ENGRANAJE Z-24
81	F03010102R	ANELLO T.A. 38X 50X 7 D3760NBR	OIL SEAL 38X 50X 7 D3760NBR	PARE-HUILE 38X 50X 7 D3760NBR	OELABDICHTUNG 38X 50X 7 D3760	PARA-ACEITE 38X 50X 7 D3760NBR

TAV.050

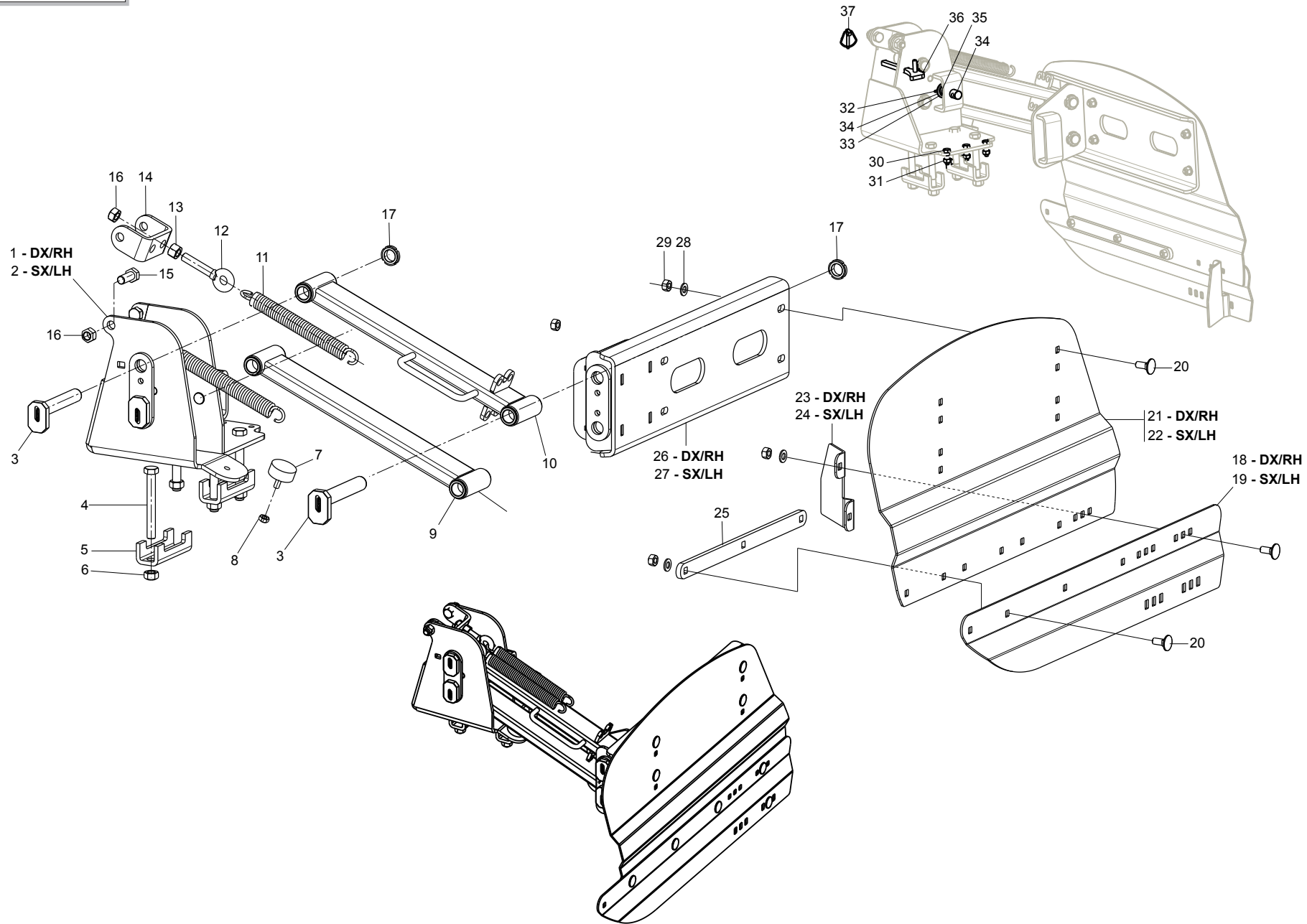

**PROTEZIONI LATERALI
SIDE PROTECTIONS**

TAV.050

Pos.	Cod.	Descrizione	Description	Benennung	Description	Description
1	M35400745R	SALDATO CINEMAT. DX BANDINELLA	WELDED RIGHT PLATE			
2	M35400744R	SALDATO CINEMAT. SX BANDINELLA	WELDED LEFT PLATE			
3	M18700538R	PERNO D=25 L= 139	PIN D=25 L= 139		BOLZEN D=25 L= 139	
4	F01010128R	VITE M16X1,5X130	SCREW M16X1,5X130	VIS M16X1,5X130	SCHRAUBE M16X1,5X130	TORNILLO M16X1,5X130
5	M36200241R	STAFFA PER TUBO DA 80	STIRRUP	ETRIER	BUEGEL	ESTRIBO
6	F01220070R	DADO M16X1,5	NUT M16X1,5	ECROU M16X1,5	MUTTER M16X1,5	TUER.M16X1,5 D980 8ZN
7	F05150460R	PARACOLPI CIL.D50X21 M10X26,5	RUBBER BUFFER- CYLINDR.D50X21	PARE-CHOCS CYL. D50X21	PUFFER ZYL.50X21	PARAGOLPES CIL.D50X21
8	F01220033R	DADO M10X1,5	NUT M10X1,5	ECROU M10X1,5	MUTTER M10X1,5	TUERCA M10X1,5 D980 8
9	M35400750R	BRACCIO PARALLELOG.CON BOCCOLE	ASS.ARM WITH BUSHINGS			
10	M35400764R	BRACCIO SUP.PARAL.CON BOCCOLE	ARM SUPP.WITH BUSHINGS			
11	B01810412R	MOLLA	SPRING	RESSORT	FEDER	MUELLE
12	M12400607R	TIRANTE M16	STRETCHER	TENDEUR	VERSTAERKUNGSROHR	SENSOR
13	F01200110R	DADO M16X2	NUT M16X2	ECROU M16X2	MUTTER M16X2	TUERCA M16
14	M35400749R	PIASTRA FISSAGGIO MOLLE	PLATE FIXED SPRINGS			
15	F01020566R	VITE M16X2X40	SCREW M16X2X40	VIS M16X2X40	SCHRAUBE M16X2X40	TORNILLO M16X2X40
16	F01220266R	DADO M16X2	NUT M16X2	ECROU M16X2	MUTTER M16X2	TUERCA M16X 2 D980 8 ZN
17	F02010011R	GHIERA AU.GUK M25X1,5 T.4H ZG	S.LOCK NUT GUK M25X1,5	COLLIER AUTOBL.	SELBSTSP. NUTMUTTER	VIROLA AUTOBL.
18	M35400772R	LAMA BANDINELLA DX	BLADE RIGHT			
19	M35400770R	LAMA BANDINELLA SX	BLADE LEFT			
20	F01060206R	VITE M12X1,75X30	SCREW M12X1,75X30	VIS M12X1,75X30	SCHRAUBE M12X1,75X30	TORNILLO M12X1,75X30
21	M35400767R	LAMIERA BANDINELLA PROTEZ. DX	RH PLATE FOR SIDE PROTECTION			
22	M35400759R	LAMIERA BANDINELLA PROTEZ. SX	LEFT PLATE FOR SIDE PROTECTION			
23	M35400768R	CONVOGLIATORE DX	RIGHT CONVEYOR			
24	M35400762R	CONVOGLIATORE SX	LEFT CONVEYOR			
25	M35400771R	SPESSORE	SPACER			
26	M35400766R	RINFORZO SALDATO DX	REINF.WELDED RIGHT			
27	M35400756R	RINFORZO SALDATO SX	REINFO.WELDED LEFT			
28	F01410076R	ROS.M1213X24X2,5	WASHER 12 13X 24X2,5	RONDELLE 12 13X 24X2,5	SCHEIBE M12 13X24X2,5 U6592 ZN	ARAND.M12 13X 24X2,5 U6592 ZN
29	F01220048R	DADO M12X1,75	NUT M12X1,75	ECROU M12X1,75	MUTTER M12X1,75	TUERCA M12X1,75 D980 8 ZN
30	F01010254R	VITE M10X1,25X35	SCREW M10X1,25X35	VIS M10X1,25X35	SCHRAUBE M10X1,25X35	TORNILLO M10X1,25X35
31	F01220034R	DADO M10X1,25	NUT M10X1,25	ECROU M10X1,25	MUTTER M10X1,25	TUER.M10X1,25 D980 8 ZB
32	F02100093R	SPINA E.P. 5X 50 U6873 C70 BR	PIN EL. 5X 50 U6873 C70 BR		SPANNSTIFT 5X45 DIN 1481 ZN *	
33	M26400780R	MOLLA	SPINRG	RESSORT	FEDER	MUELLE
34	M35400780R	PERNO DI SBLOCCO	SBLOCKED PIN			
35	F01410135R	ROS.M22 23X 39X 3	WASHER M22 23X 39X 3	RONDELLE M22 23X 39X 3	SCHEI. M22 23X 39X3 U6592 ZN	ARANDELLA M22 23X39X3 U6592 ZN
36	M35400781R	ECCENTRICO	ECCENTRICO			
37	F02200452R	SPINA SCATTO D.4,4 B 80 ZN	SNAP PIN D4.4 B 80 ZN	FICHE A DETENTE D4.4 B 80 ZN	EINRASTSTIFT D4.4 B 80 ZN	CLAVIJA DE MUELLE D4,4 B 80 ZN

TAV.060

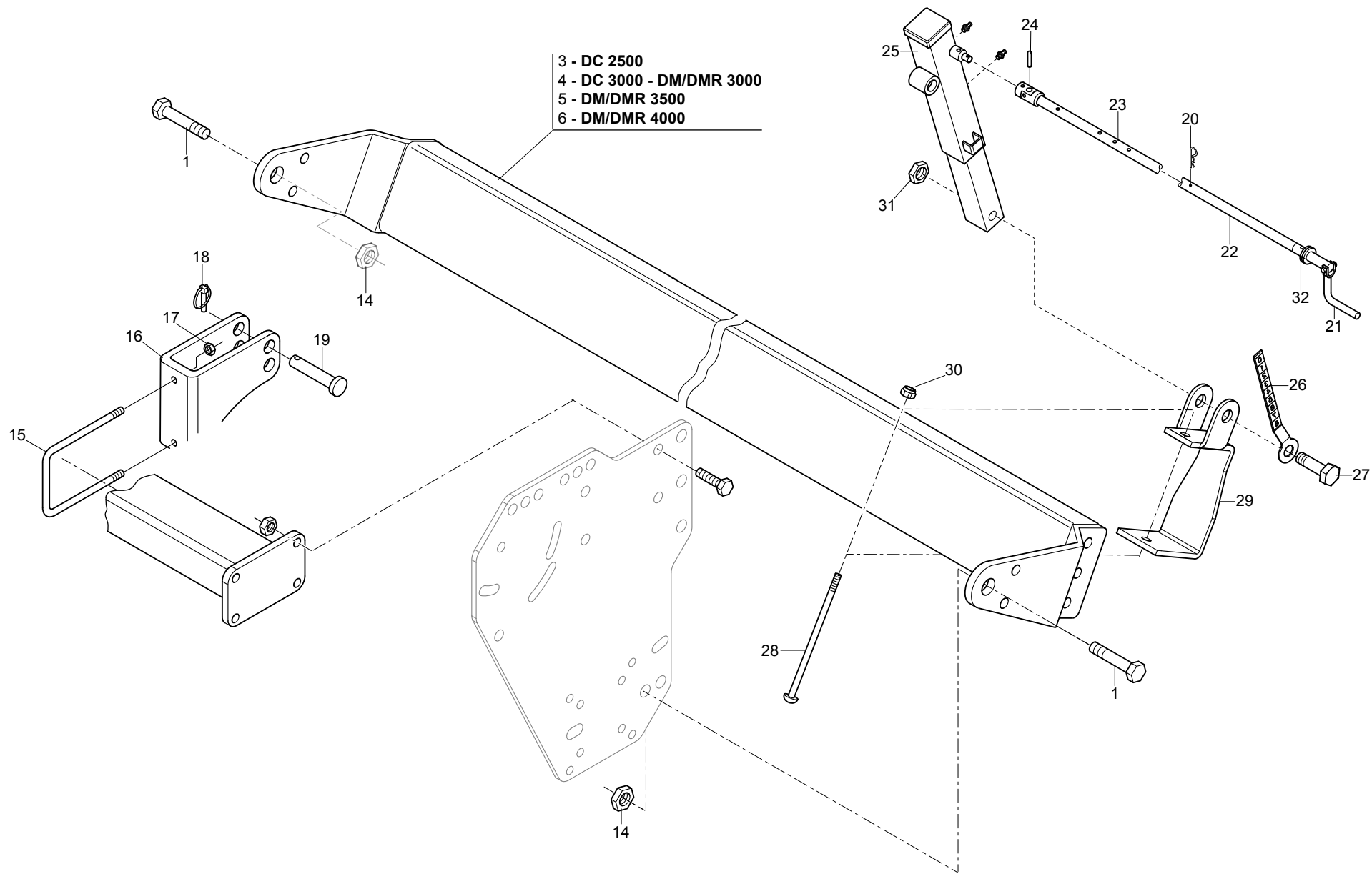

**BARRA LIVELLATRICE
LEVELING BAR**

TAV.060

Pos.	Cod.	Descrizione	Description	Benennung	Description	Description
1	F01010364R	VITE M18X1,5X50	SCREW M18X1,5X50	VIS M18X1,5X50	SCHRAUBE M18X1,5X50	TORNILLO M18X1,5X50
3	M23425783R	BARRA LIVELLATRICE 2500	REAR BAR 2500	BARRE ARRIERE 2500	KOMPL. HINTERE SCHINE 2500	BARRA TRASERA 2500
4	M23430783R	BARRA LIVELLATRICE 3000	REAR BAR 3000	BARRE ARRIERE 3000	KOMPL. HINTERE SCHINE 3000	BARRA TRASERA 3000
5	M23435783R	BARRA LIVELLATRICE 3500	REAR BAR 3500	BARRE ARRIERE 3500	KOMPL. HINTERE SCHINE 3500	BARRA TRASERA 3500
6	M23440783R	BARRA LIVELLATRICE 4000	REAR BAR 4000	BARRE ARRIERE 4000	KOMPL. HINTERE SCHINE 4000	BARRA TRASERA 4000
14	F01220081R	DADO M18X1,5	NUT M18X1,5	ECROU M18X1,5	MUTTER M18X1,5	DADO AUTOBL. M18X1,5 980-V
15	F20110800R	CAV.R.B=100 M=16X2 L=135	U BOLT R.B=100 M=16X2 L=135	ATTEL.B=100 M=16X2 L=135	VERBI.B=100 M=16X2 L=135	PERNO U B=100 M=16X2 L=135
16	M23400444R	STAFFA ATTACCO MARTINETTO	ADJUST HITCH PLATE		BUEGELLINK	
17	F01230085R	DADO M16X2 D982 10ZN	NUT M16X2	ECROU M16X2	MUTTER M16X2	TUERCA M16X2 D982 10ZN
18	F02200529R	SPINA SCATTO D.11 H58 ZN	SNAP PIN D.11 H58 ZN	FICHE A DETENTE D.11 H58 ZN	EINRASTSTIFT D.11 H58 ZN	CLAVIJA DE MUELLE D.11 H58 ZN
19	F20100049R	PERNO D22 L86 C43 TEST.D35 ZN	BOLT D22 L86 C43 ZN	GOUJON D.22	BOLZEN D.22	PERNO D.22
20	F02200374R	COPIGLIA R 4X 82 ZN	SPRING SPLIT PIN 4X82	GOUPILLE 4X82	SPLINT 4X82	PASADOR 4X82
21	M36200808R	COMP. MANICO VITE	HANDLE SCREW		REGULIERUNGHEFT	
22	M12400460R	ASTA ESTERNA	EXTERNAL BEAM		AUSSENHOLM	
23	M12400461R	COMP.ASTA INTERNA	INTERNAL BEAM ASSEMBLY		INNENHOLM	
24	F02100086R	SPINA E.P. 5X 30 U6873 C70 ZN	PIN EL. 5 X30 DIN 1481 GALVAN.	FICHE EL. 5 X30 DIN 1481 ZN	SPANNSTIFT 5 X30 DIN 1481 ZN	CLAVIJA EL.P. 5X 30 U6873 C70
25	M23400917R	MARTINETTO REG. 180 - 330	MECHANICAL ADJUSTER 180 - 330			
26	M23400945R	COMP.ASTA REGOLAZ. MARTINETTI	RULER ASSEMBLY		SKALA WALZENVERSTELLUNG	
27	F01010194R	VITE M22X1,5X110	SCREW M22X1,5X110	VIS M22X1,5X110	SCHRAUBE M 22X1,5X110	TORNILLO M22X1,5X110
28	F01060209R	VITE M10X1,5X200	SCREW M10X1,5X200	VIS M10X1,5X200	SCHRAUBE M10X1,5X200	TORNILLO M10X1,5X200
29	M43400464R	PIASTRA ATTACCO MARTINETTO	PLATE PF JACK ATTACK		WINDEHALTERUNG PLATTE	
30	F01220033R	DADO M10X1,5	NUT M10X1,5	ECROU M10X1,5	MUTTER M10X1,5	TUERCA M10X1,5 D980 8
31	F01230269R	DADO M22X1,5	NUT M22X1,5	ECROU M22X1,5	MUTTER M22X1,5	DADO AUTOBL.M22X1,5 D985 6S ZN
32	F01460051R	DISCO ELASTICO 40X20,3X2	CUP SPRING 40X 20,3X 2 D2093		ELASTISCHE SCHEIBE	

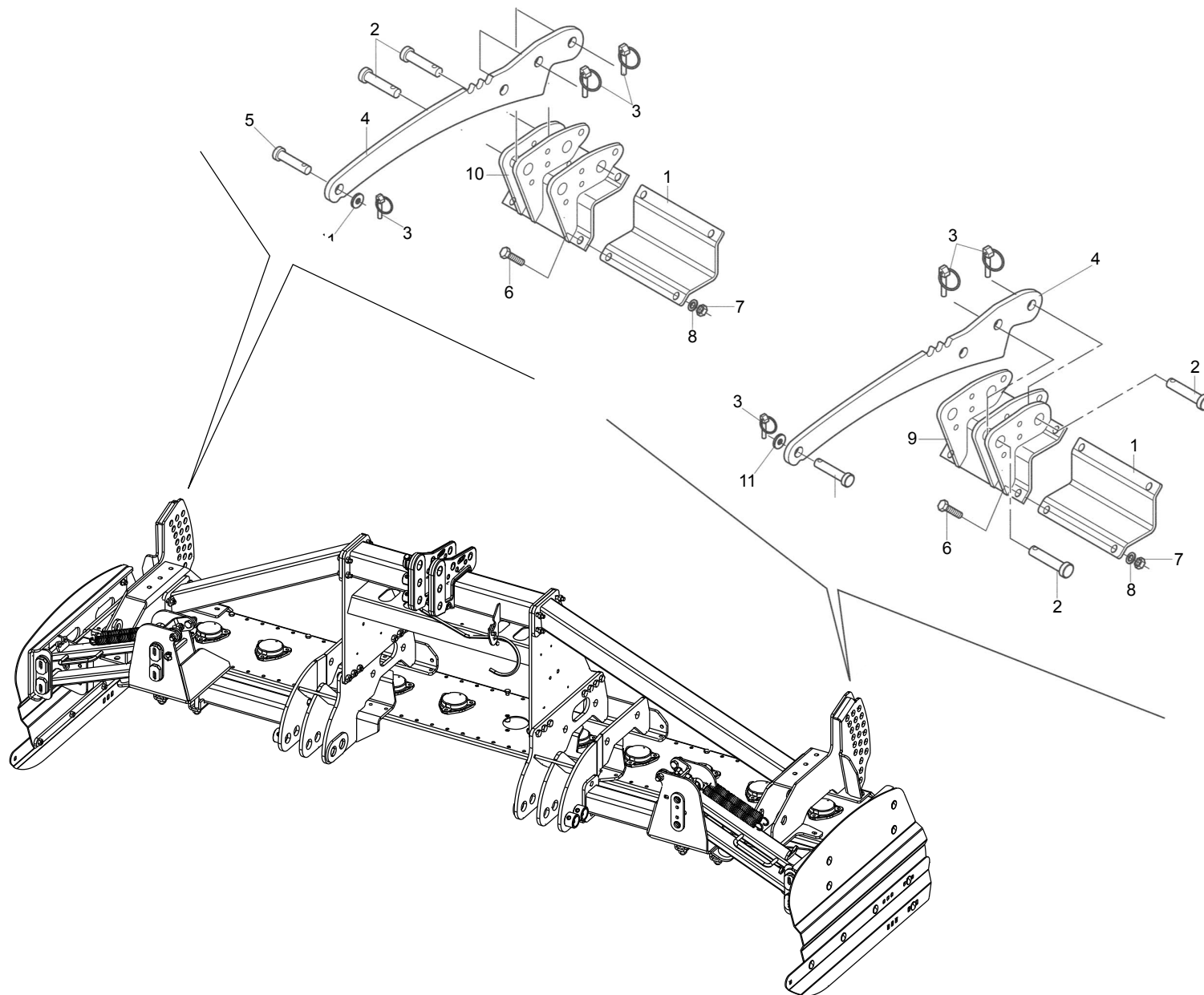

**BRACCIO COLLEGAMENTO RULLO (VERS. COMBI)
ROLLER CONNECTING BRACKET (COMBI VERSION)**

TAV.070

Pos.	Cod.	Descrizione	Description	Benennung	Description	Description
1	M44400403R	STAFFA ATTACCO RULLO DX	ROLLER CONNECTION SUPPORT	SUPPORT ROULEAU DROITE	SCHUTZHOLM WALZE	SOPORTE RODILLO DERECHA
2	F20100090R	PERNO D32 L64 C43 TEST.D45 ZN	PIN D32 L64	GOUJON D32 L64	STIFT D32 L64 ZN	PERNO D32 L64
3	F02200529R	SPINA SCATTO D.11 H58 ZN	SNAP PIN D.11 H58 ZN	FICHE A DETENTE D.11 H58 ZN	EINRASTSTIFT D.11 H58 ZN	CLAVIJA DE MUELLE D.11 H58 ZN
4	M44400405R	BRACCIO COLLEGAMENTO RULLO	ROLLER CONNECTING ARM	BRAS DE CONNECTION ROULEAU	WALZE VERBINDUNGSARM	BRAZO DE CONEXI N RODILLO
5	F20100124R	PERNO D32 L135 C40 TEST.D45 Z	BOLT D32 L135 C40 ZN	BOULON D32 L135 C40 ZN	BOLZEN D32 L135 C40 ZN	PERNO D32 L135 C40 ZN
6	F01010341R	VITE M16X1,5X45 U5740 8.8ZN	SCR. M16X1,5X45 U5740 8.8ZN	VIS M16X1,5 X45 U5740 8.8 ZN	SCHR.M16X1,5 X45 U5740 8.8 ZN	TORN.M16X1,5 X45 U5740 8.8 ZN
7	F01220070R	DADO M16X1,5	NUT M16X1,5	ECROU M16X1,5	MUTTER M16X1,5	TUER.M16X1,5 D980 8ZN
8	F01410100R	ROS.M16 17X30X 3	WASHER M16 17X30X3	RONDELLE M16 17X30X3	SCHRAUBE M16 17X 30X3 U6592 ZN	ARAND.M16 17X 30X 3 U6592 ZN
9	M44400404R	STAFFA ATTACCO RULLO SX	LEFT ROLLER CONNECTION SUPP.	SUPPORT ROULEAU GAUCHE	LINKS SCHUTZHOLM WALZE	SOPORTE RODILLO IZQUIERDO
10	M44400401R	STAFFA ATTACCO RULLO DX	RIGHT ROLLER CONNECTION SUPP.	SUPPORT ROULEAU RECHTE	RECHTE SCHUTZHOLM WALZE	SOPORTE RODILLO DERECHO
11	M23400422R	DISTANZIALE D=60 D=32,5 L=4	SPACER D=60 D=32,5 L=4	ENTRETOISED=60 D=32,5 L=4	DISTANZSTUECK D=60 D=32,5 L=4	DISTANCIADOR D=60 D=32,5 L=4

TAV.080

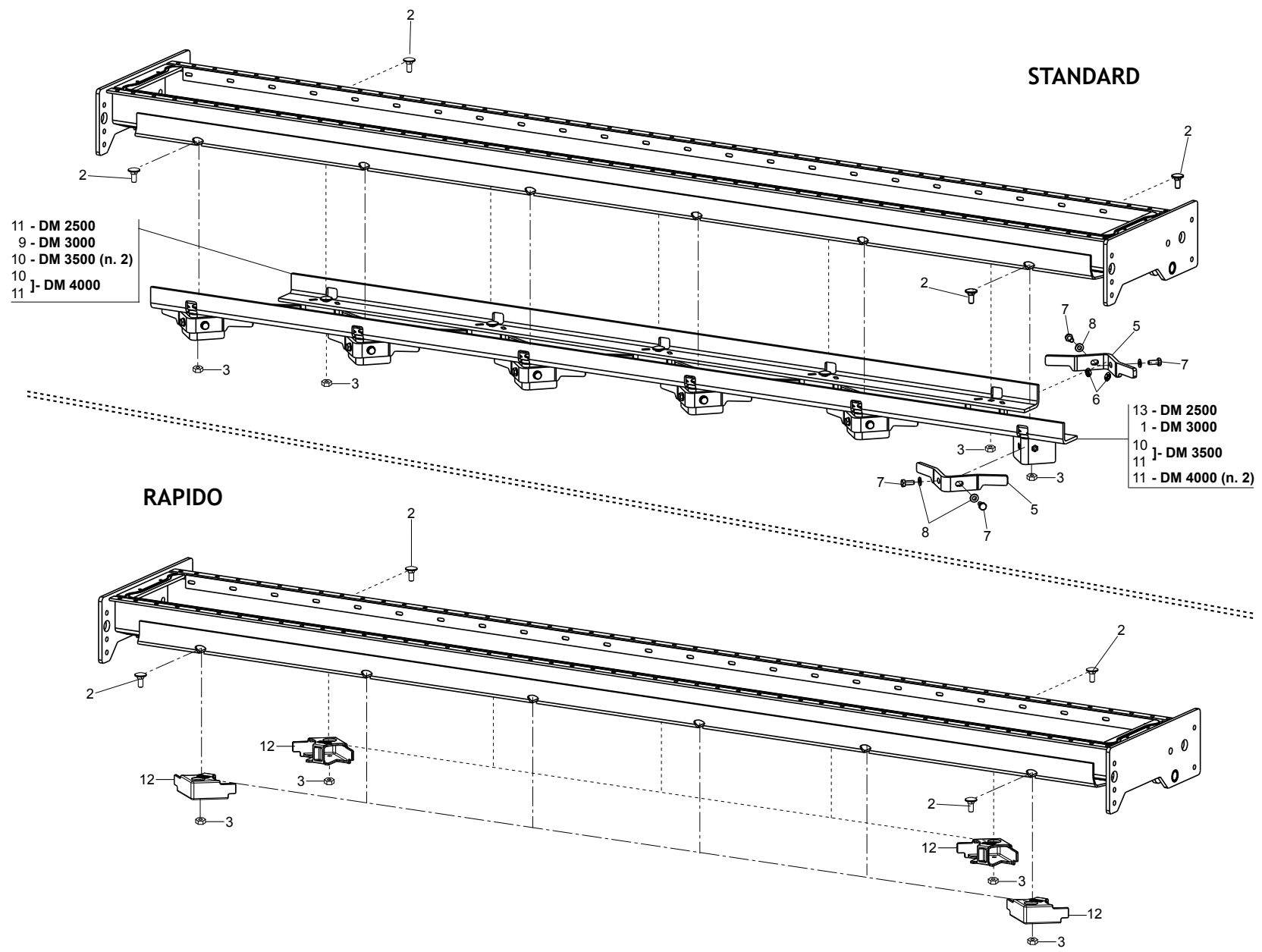

**CUNEI DEFLETTORI AVVITATI
BOLT-ON STEEL DEFLECTORS**

TAV.080

Pos.	Cod.	Descrizione	Description	Benennung	Description	Descripcion
1	M26430806R	PLUS SALDATO 3000	PLUS WELDED L=--		PLUS GESCHWEISST L=--	
2	F01060206R	VITE M12X1,75X30	SCREW M12X1,75X30	VIS M12X1,75X30	SCHRAUBE M12X1,75X30	TORNILLO M12X1,75X30
3	F01220048R	DADO M12X1,75	NUT M12X1,75	ECROU M12X1,75	MUTTER M12X1,75	TUERCA M12X1,75 D980 8 ZN
5	M26400815R	DEFLETTORE CUNEO	CARTER DEFLECTOR		GEHAEUSE DEFLEKTOR	
6	F01260049R	DADO FL.M10X1.5 CH15	NUT FL.M10X1.5 CH15	ECROU FL.M10X1.5 CH15	MUTTER M10X1.5 CH15 D6923 8 ZN	
7	F01020472R	VITE M10X1,5X25	SCREW M10X1,5X25	VIS M10X1,5X25	SCHRAUBE M10X1,5X25	TORNILLO M10X1,5X25
8	F01410062R	ROS.M10 10,5X 18X 2	WASHER M10 10,5X 18X 2	RONDELLE M10 10,5X 18X 2	DICHTUNGSRING M10 10,5X18X2 ZN	ARAND.M10 10,5X 18X 2 U6592 ZN
9	M26425806R	PLUS SALDATO 2500	PLUS WELDED L=--		PLUS GESCHWEISST L=--	
10	M26418806R	PLUS SALDATO 1800	PLUS WELDED L=--		PLUS GESCHWEISST L=--	
11	M26420806R	PLUS SALDATO 2000	PLUS WELDED L=--		PLUS GESCHWEISST L=--	
12	M52400525R	CUNEO RINFORZO VERSIONE PLS RP	STIFFENING WEDGE	COIN DE RENFORCEMENT	VERSTAERKUNGSKEIL	CU A DE REFUERZO
13	M26425806R	PLUS SALDATO 2500	PLUS WELDED L=--		PLUS GESCHWEISST L=--	

TAV.090

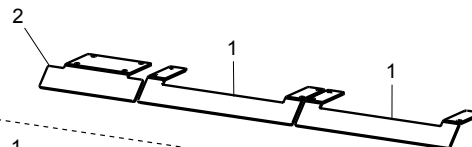
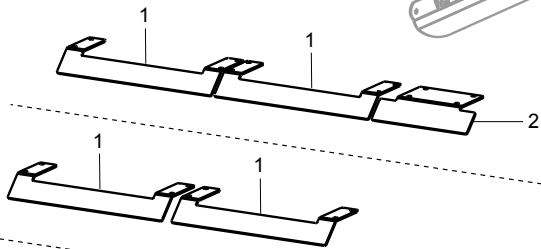
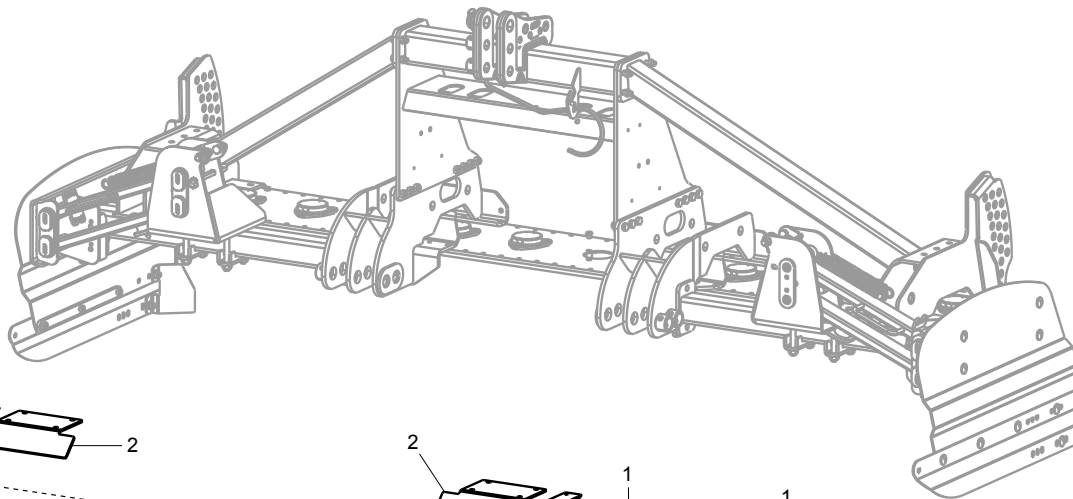

MOD.4000

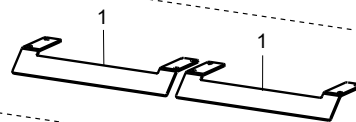

MOD.3500

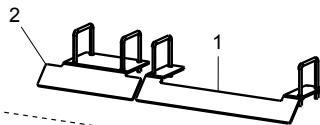
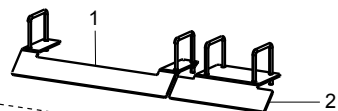

MOD.3000

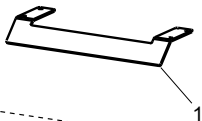
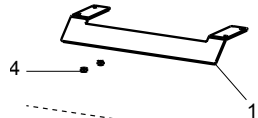

MOD.2500

**GRUPPO PROTEZIONI CE (ANTERIORI)
(FRONT) EC GUARDS UNIT**

TAV.090

Pos.	Cod.	Descrizione	Description	Benennung	Description	Description
1	M35400793R	PROTEZIONE CE ANTERIORE	FRONT PROTECTION CE			
2	M23400552R	PROTEZ. ANTERIORE CE	FRONT PROTECTION CE	PROTECTION AVANT CE	VORDERER SCHUTZ CE	PROTECCION DELANTERA CE
3	F20110730R	CAV.Q.B=80 M=10X1,5 L=109	U BOLT.Q.B=80 M=10X1,5 L=109	BUTEE M10X 1,5X 30 91X 99 ZB	ANSCHLAG M10X 1,5X 30 91X 99	EL. DE EMPALME M10X 1,5X 30
4	F01220033R	DADO M10X1,5	NUT M10X1,5	ECROU M10X1,5	MUTTER M10X1,5	TUERCA M10X1,5 D980 8

TAV.100

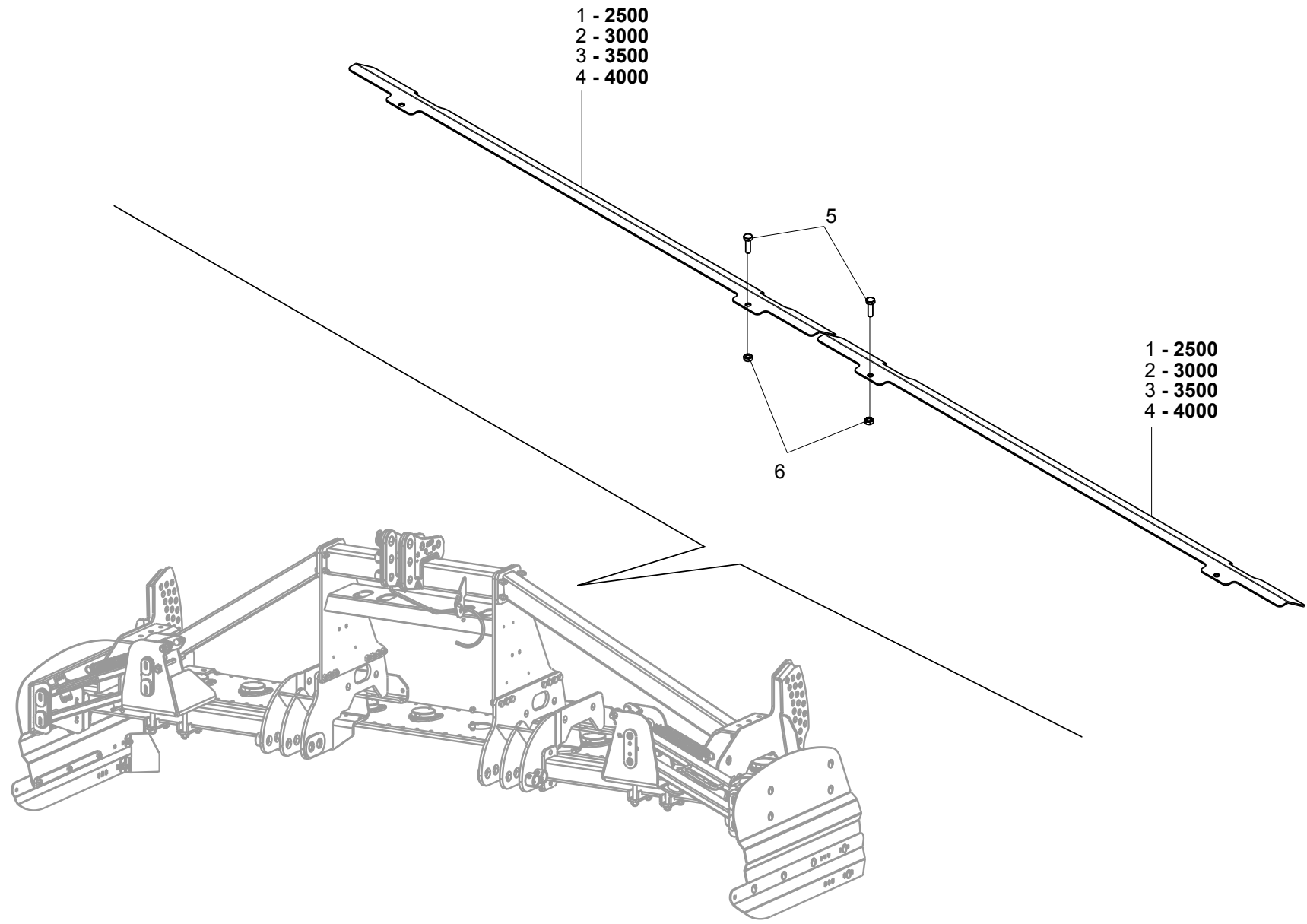

**GRUPPO PROTEZIONI <<CE>> (POSTERIORI)
(REAR) <<EC>> GUARDS UNIT**

TAV.100

Pos.	Cod.	Descrizione	Description	Benennung	Description	Description
1	M35425798R	PROTEZIONE POSTERIORE CE	REAR PROTECTION CE			
2	M35430798R	PROTEZIONE POSTERIORE CE	REAR CE PROTECTION			
3	M35435798R	PROTEZIONE POSTERIORE CE	REAR CE PROTECTION			
4	M35440798R	PROTEZIONE POSTERIORE CE	REAR CE PROTECTION			
5	F01010262R	VITE M10X1,25X50	SCREW M10X1,25X50	VIS M10X1,25X50	SCHRAUBE M10X1,25X50	TORNILLO M10X1,25X50
6	F01200268R	DADO M10X1,25	NUT M10X1,25	ECROU M10X1,25	MUTTER M10X1,25	TUER. M10X1,25

TAV.110

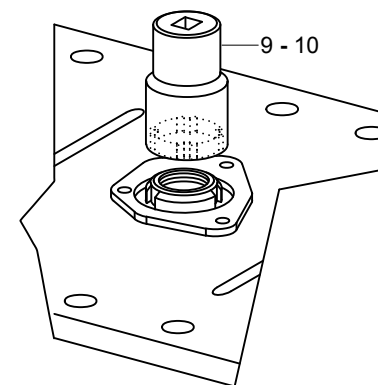
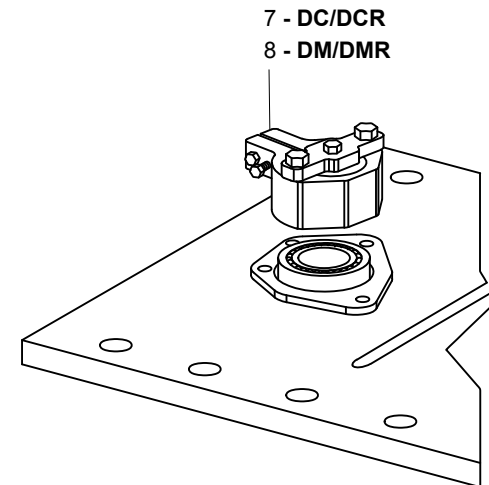
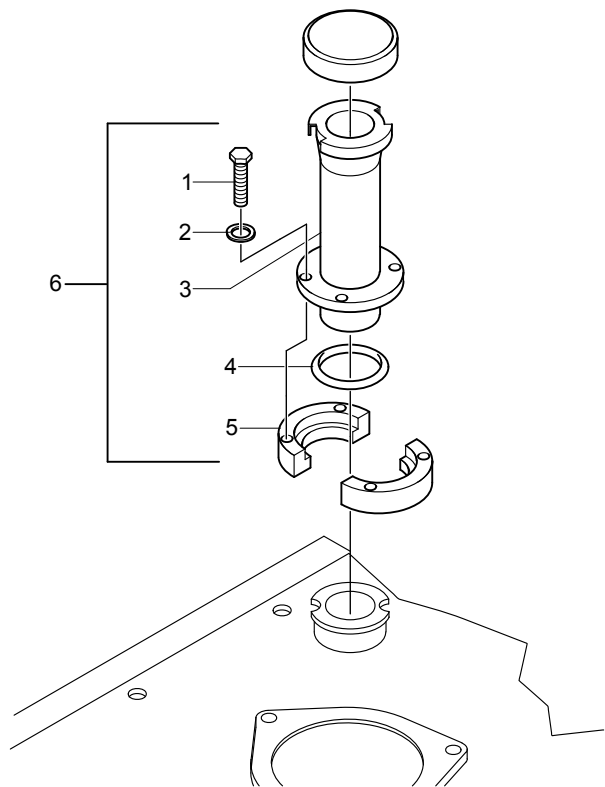

**OPTIONALS
OPTIONALS**

TAV.110

Pos.	Cod.	Descrizione	Description	Benennung	Description	Description
1	F01020406R	VITE M6X1X25	SCREW M6X1X25	VIS M6X1X25	SCHRAUBE M6X1X25	TORNILLO M6X1X25
2	F01480088R	ROS.G 6,4X12,4X2	GROWER WASHER D.6	GROWER RONDELLE D.6	SCHEIBE GROWER D.6	ARANDELA GROWER D.6
3	M36200856R	SEMIFLANGIA INFERIORE	FLANGE	FLASQUE	FLANSCH	BRIDA
4	F03010552R	ANELLO OR 45,69X2,62 NBR	GASKET OR 45,69X2,62 NBR	BAGUE OR 45,69X2,62 NBR	RING OR 45,69X2,62 NBR	ANILLO OR 45,69X2,62 NBR
5	M36200856R	SEMIFLANGIA INFERIORE	FLANGE	FLASQUE	FLANSCH	BRIDA
6	M36299001R	KIT PROLUNGA CARICO OLIO ERP.	OIL PLUG EXTENSION	REHAUSSE BOUCHON HUILE HERSE	OLVERSCHLUSSVERLAENGERUNG	PROLONGAMIENTO TAPON ACEITE
7	M38100307R	ESTRATTORE CUSC.SUP. DL-DS-DC	EXTRACTOR	EXTRACTEUR	LAGER AUSZIEHER	EXTRACTOR PARA RODAMIENTO
8	M36100335R	ESTRATTORE CUSC.SUP. DM	BEARING EXTRACTOR	EXTRACTEUR	LAGER AUSZIEHER	EXTRACTOR PARA RODAMIENTO
9	M38100306R	CHIAVE PER GHIERA M45X1,5 ZN	KEY D.45X1,5	CLE D.45X1,5	SCHLUESSEL F. MUTTER D.45X1,5	LLAVE M45X1,5 ZN
10	M36100334R	CHIAVE PER GHIERA M50X1,5 ZN	KEY FOR SELF LOCKING NUT	CLE M50X1,5	SCHLUESSEL F. MUTTER	LLAVE M50X1,5 ZN

**ROMPITRACCIA A MOLLE
TRACK ERADICATOR SAFETY SPRIGS**

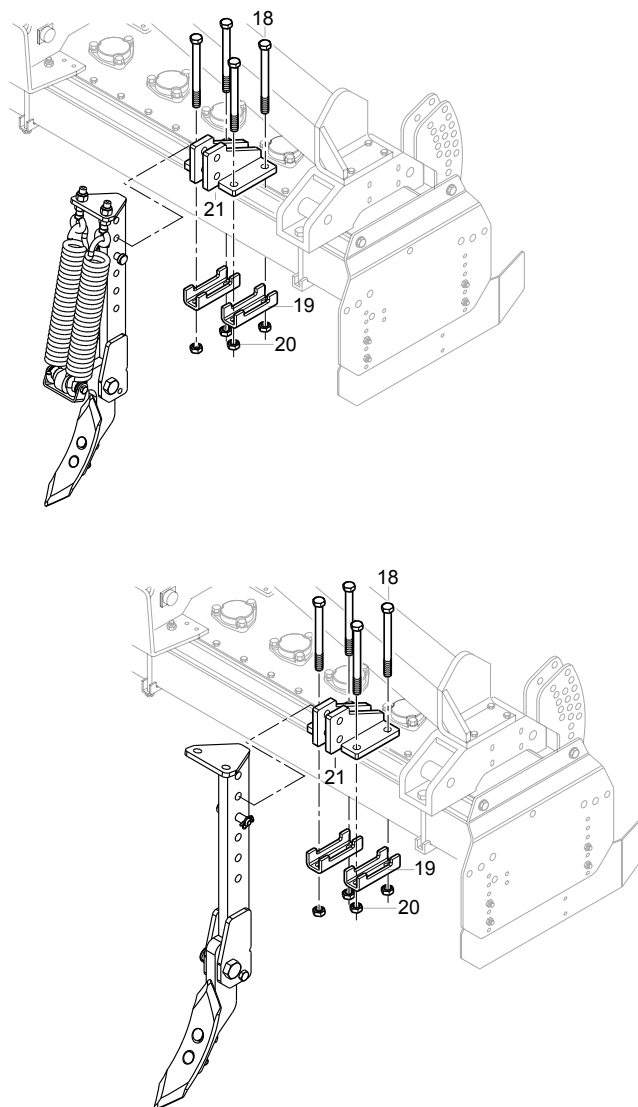
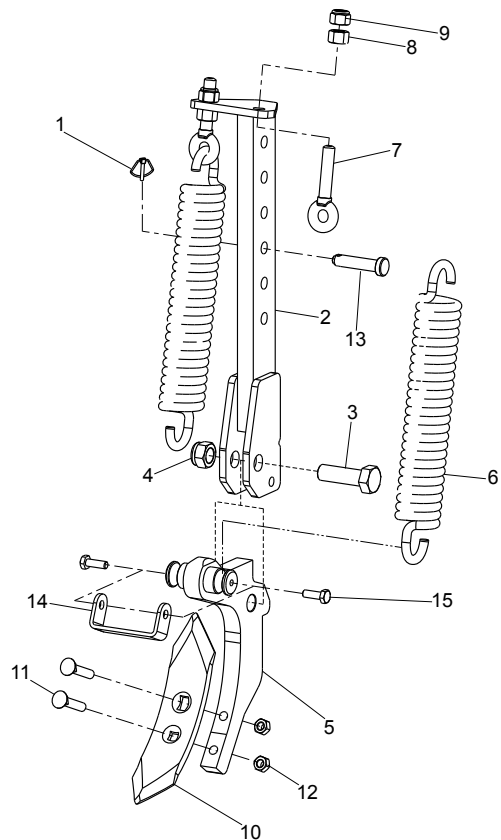

**ROMPITRACCIA A BULLONE DI TRANCIO
TRACK ERADICATOR SAFETY SHEAR BOLT**

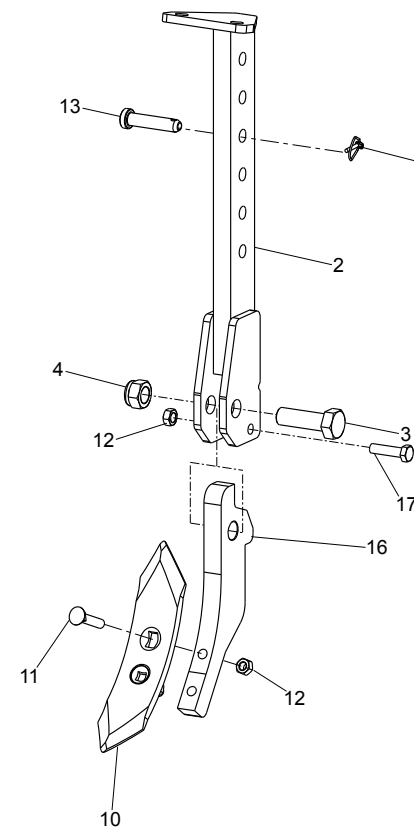

**OPTIONALS
OPTIONALS**

TAV.120

Pos.	Cod.	Descrizione	Description	Benennung	Description	Description
1	F02200452R	SPINA SCATTO D.4,4 B 80 ZN	SNAP PIN D4.4 B 80 ZN	FICHE A DETENTE D4.4 B 80 ZN	EINRASTSTIFT D4.4 B 80 ZN	CLAVIJA DE MUELLE D4,4 B 80 ZN
2	M35400602R	COMP.SUPP.ANCORA ROMPITRACCIA	WHEEL TRACK ERADIC.SUB.SUPPORT		HALTER F R SPURLOCKERER	
3	F01010398R	VITE M22X1,5X70	SCREW M22X1,5X70	VIS M22X1,5X70	SCHRAUBE M22X1,5X70	TORNILLO M22X1,5X70
4	F01230269R	DADO M22X1,5	NUT M22X1,5	ECROU M22X1,5	MUTTER M22X1,5	DADO AUTOBL.M22X1,5 D985 6S ZN
5	M35400625R	COMP.ROMPITR.X MOLLE CON PERNO	WHEEL TRACK ERADICATOR SPRINGS		FEDER	
6	M12400612R	MOLLA	SPRING		VERSTAERKUNGSROHR	TENSOR
7	M12400607R	TIRANTE M16	STRETCHER	TENDEUR	MUTTER M16X2	TUERCA M16
8	F01200110R	DADO M16X2	NUT M16X2	ECROU M16X2	MUTTER M16X2	TUERCA M16X2 D982 10ZN
9	F01230085R	DADO M16X2 D982 10ZN	NUT M16X2	ECROU M16X2	MUTTER M16X2	TUERCA M16X2 D982 10ZN
10	F20120009R	VOMERINO	PLOWSHARE		PFLUGSCHAR	
11	F01030117R	KIT V.M12X1,75X60 U6104 8.8ZN	KIT M12X1,75X60	VIS M12X1,75X60	SCHRAUBE M12X1,75X60	TORNILLO M12X1,75X60
12	F01220048R	DADO M12X1,75	NUT M12X1,75	ECROU M12X1,75	MUTTER M12X1,75	TUERCA M12X1,75 D980 8 ZN
13	F20100021R	PERNO D16 L70 C40 TEST.D25 ZN	PIN D16 L70 C40 TEST.D25 ZN		BOLZEN D16 L70 C40 TEST.D25 ZN	
14	M73400637R	PROTEZIONE MOLLE	SAFETY SPRING		SICHERHEITSFEDER	
15	F01020476R	VITE M10X1,5X30	SCREW M10X1,5X30	VIS M10X1,5X30	SCHRAUBE M10X1,5X30	TORNILLO M10X1,5X30
16	M35400624R	ROMPITRACCIA LATERALE	LATERAL WHEEL TRACK ERADICATOR		SEITLICHER SPURLOCKERER	
17	F01020160R	VITE M12X1,75X60	SCREW M12X1,75X60	VIS M12X1,75X60	SCHRAUBE M12X1,75X60	TORNILLO M12X1,75X60
18	F01010135R	VITE M16X1,5X180	SCREW M16X1,5X180	VIS M16X1,5X180	SCHRAUBE M16X1,5X180	TORNILLO M16X1,5X180
19	M36200241R	STAFFA PER TUBO DA 80	STIRRUP	ETRIER	BUEGEL	ESTRIBO
20	F01220070R	DADO M16X1,5	NUT M16X1,5	ECROU M16X1,5	MUTTER M16X1,5	TUER.M16X1,5 D980 8ZN
21	M35400607R	PIASTRA SUPP.ROMPITR.MONOTRAVE	SUPPORT PLATE WHEEL TRACK ERAD		HALTER PLATTE RAD TRACK ERAD	

TAV.130

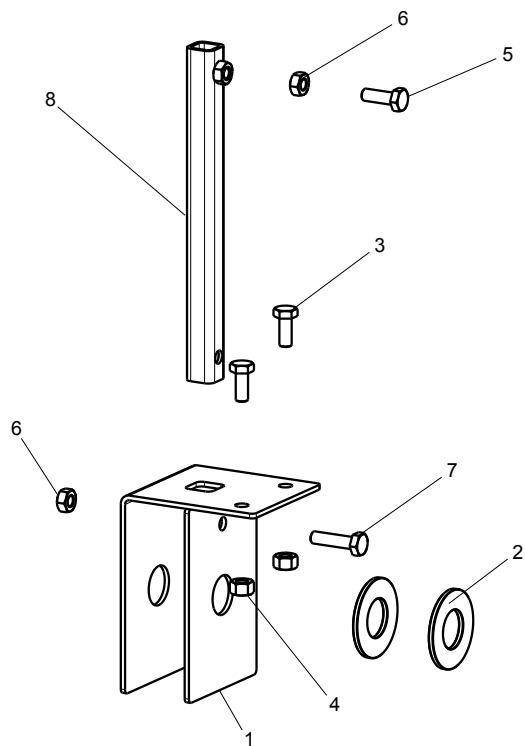

**KIT SUPPORTI PER TRASPORTO STRADALE
ROAD TRANSPORT SUPPORTS KIT**

TAV.130

Pos.	Cod.	Descrizione	Description	Benennung	Description	Description
1	M35400784R	C PER SUPPORTO TABELLA	C FOR SUPPORT TABLE			
2	M23400422R	DISTANZIALE D=60 D=32,5 L=4	SPACER D=60 D=32,5 L=4	ENTRETOISED=60 D=32,5 L=4	DISTANZSTUECK D=60 D=32,5 L=4	DISTANCIADOR D=60 D=32,5 L=4
3	F01010244R	VITE M10X1,25X25	SCREW M10X1,25X25	VIS M10X1,25X25	SCHRAUBE M10X1,25X25	TORNILLO M10X1,25X25
4	F01200048R	DADO M10X1,25G	NUT M10X1,25G	ECROU M10X1,25G	MUTTER M10X1,25G	DADO M10X1,25
5	F01020476R	VITE M10X1,5X30	SCREW M10X1,5X30	VIS M10X1,5X30	SCHRAUBE M10X1,5X30	TORNILLO M10X1,5X30
6	F01200270R	DADO M10X1,5	NUT M10X1,5	ECROU M10X1,5	MUTTER M10X1,5	TUERCA M10X1,5 U5588 CL8 ZN
7	F01020110R	VITE M10X1,5X40	SCREW M10X1,5X40	VIS M10X1,5X40	SCHRAUBE M10X1,5X40	TORNILLO M10X1,5X40
8	M35400789R	SUPPORTO TABELLA TUBO	SUPPORT TABLE PIPE			

TAV.140

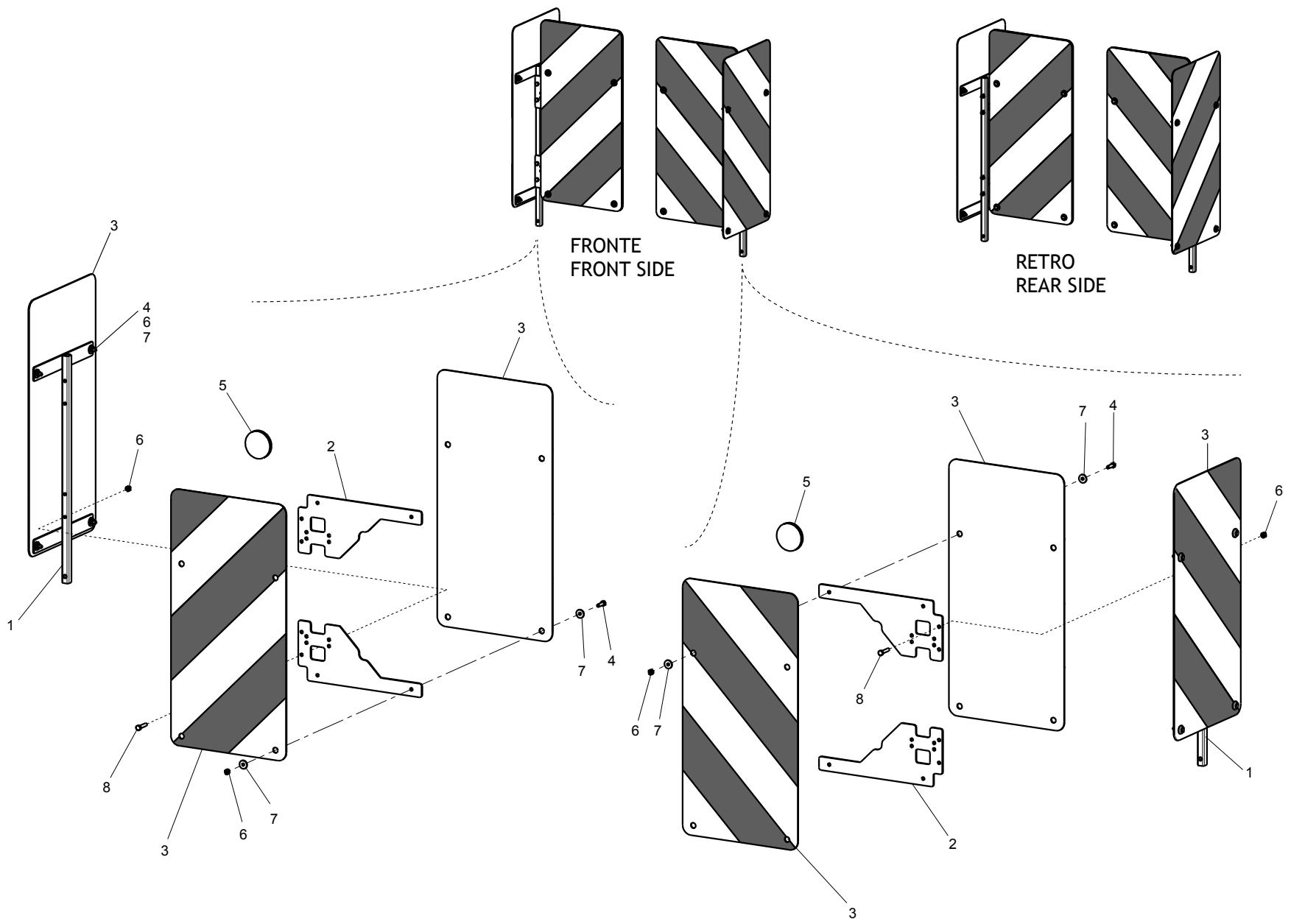

KIT TABELLE STRADALI G99600006
ROAD TRANSPORT KIT G99600006

TAV.140

Pos.	Cod.	Descrizione	Description	Benennung	Description	Description
1	G16612070R	TELAIO SUPP.TABELLE STRAD.	FRAME SUPPORT TABLE			
2	M04700558R	SUPPORTO TABELLA INGOMBRO	LIGHT-CHART SUPPORT			
3	F05010816R	TABELLE 2 CAR.SPORGENTI IT	WARNING BOARDS 2 IT	PANNEAU 2 SIGNALISATION IT	LICHT-TABELLE HALTER	TABLAS 2 CAR.ADVERT. IT
4	F01020404R	VITE M6X1X20	SCREW M6X1X20	VIS M6X1X20	SCHRAUBE M6X1X20	TORNILLO M6X1X20
5	F05010820R	CATARIFR.TONDO D60 ROSSO	ROUND REFLECTOR D.60 RED		REFLEKTOR RUND ROT D.60MM	
6	F01220011R	DADO M6X1	NUT M6X1	ECROU M6X1	MUTTER M6X1	TUERCA M6X1 D980 8 ZN
7	F01420036R	ROS.M6 6,4X 18X1,5	WASHER M6 6,4X 18X1,5	RONDELLE M6 6,4X 18X1,5	SCHEIBEN M6 6,4X18X1,5U6593 ZN	ARANDELA M6 6,4X18X1,5U6593ZN
8	F01020408R	VITE M6X1X30	SCREW M6X1X30	VIS M6X1X30	SCHRAUBE M6X1X30	TORNILLO M6X1X30

TAV.150

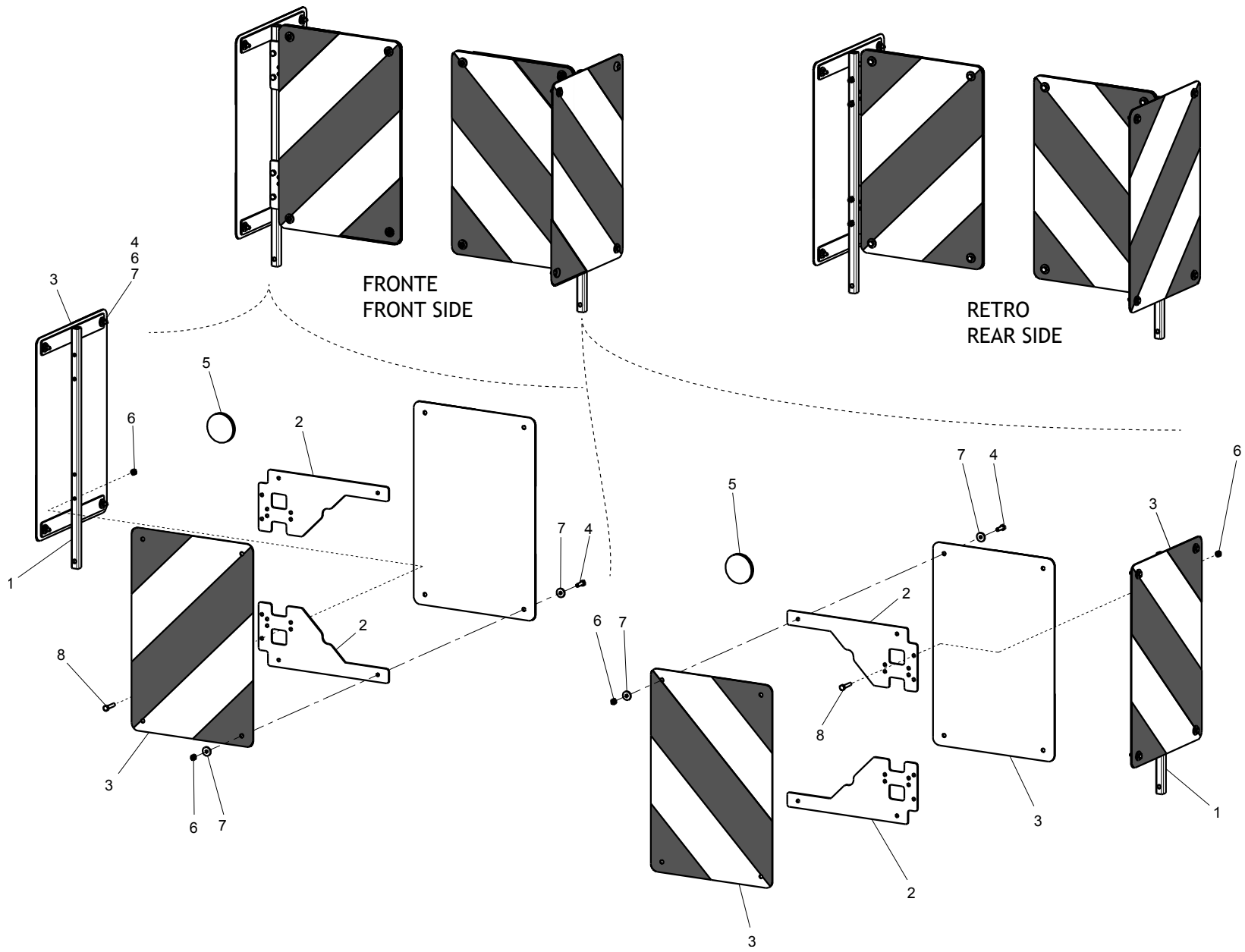

**KIT TABELLE STRADALI G99600017
ROAD TRANSPORT KIT G99600017**

TAV.150

Pos.	Cod.	Descrizione	Description	Benennung	Description	Description
1	G16612070R	TELAIO SUPP.TABELLE STRAD.	FRAME SUPPORT TABLE			
2	M04700558R	SUPPORTO TABELLA INGOMBRO	LIGHT-CHART SUPPORT			
3	F05010817R	TABELLE 2 CAR.SPORGENTI FR-D	WARNING BOARDS 2 FR-DE	TABLEAUX 2 AVERTISSEM. FR-DE	LICHT-TABELLE HALTER	TABLAS 2 CAR.ADVERT. FR-DE
4	F01020404R	VITE M6X1X20	SCREW M6X1X20	VIS M6X1X20	BRETT 2 WARNUNG FR-DE	TORNILLO M6X1X20
5	F05010820R	CATARIFR.TONDO D60 ROSSO	ROUND REFLECTOR D.60 RED		SCHRAUBE M6X1X20	REFLEKTOR RUND ROT D.60MM
6	F01220011R	DADO M6X1	NUT M6X1	ECROU M6X1	MUTTER M6X1	TUERCA M6X1 D980 8 ZN
7	F01420036R	ROS.M6 6,4X 18X1,5	WASHER M6 6,4X 18X1,5	RONDELLE M6 6,4X 18X1,5	SCHEIBEN M6 6,4X18X1,5U6593 ZN	ARANDELA M6 6,4X18X1,5U6593ZN
8	F01020408R	VITE M6X1X30	SCREW M6X1X30	VIS M6X1X30	SCHRAUBE M6X1X30	TORNILLO M6X1X30

TAV.160

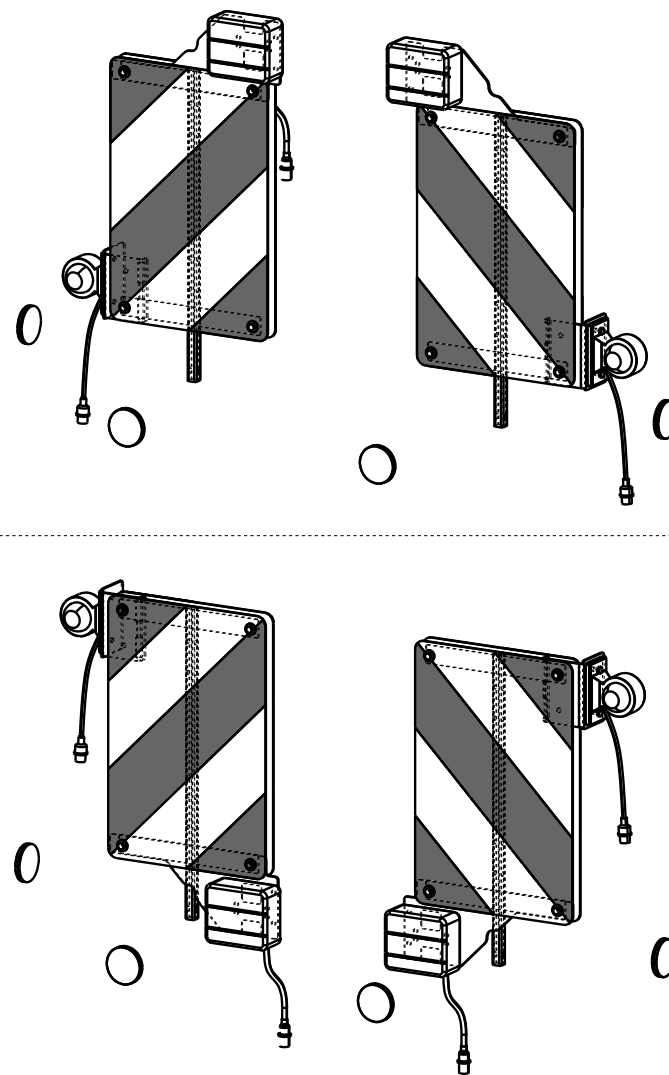
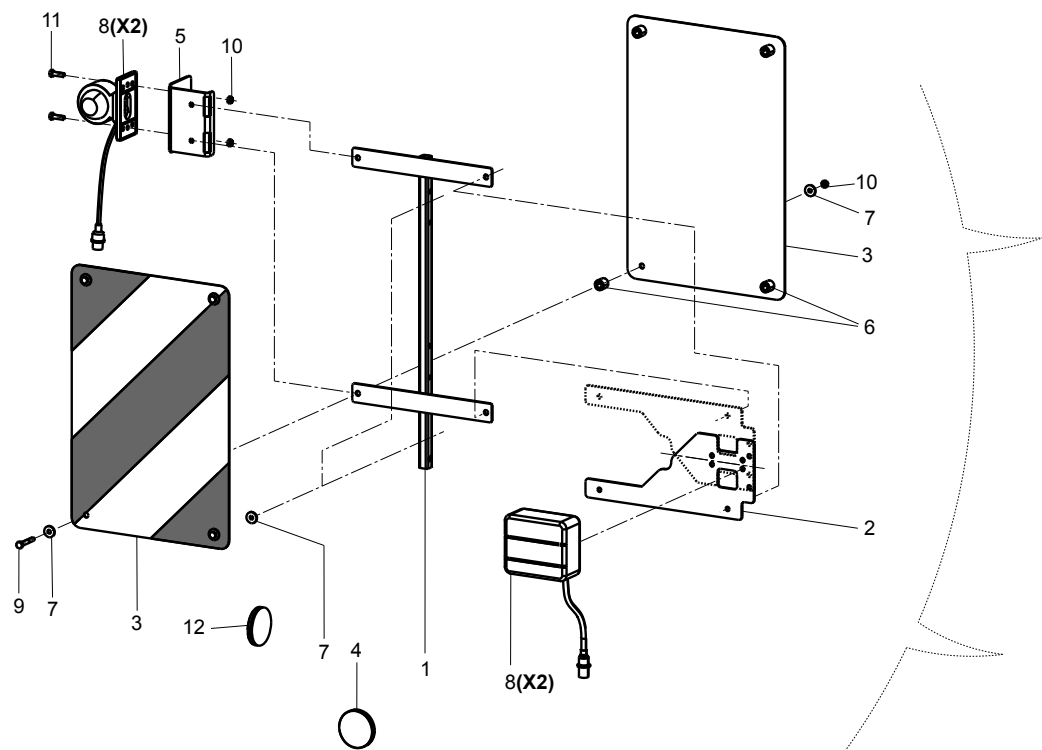

**KIT TABELLE STRADALI G99600018
ROAD TRANSPORT KIT G99600018**

TAV.160

Pos.	Cod.	Descrizione	Description	Benennung	Description	Description
1	G16612070R	TELAIO SUPP.TABELLE STRAD.	FRAME SUPPORT TABLE			
2	M04700558R	SUPPORTO TABELLA INGOMBRO	LIGHT-CHART SUPPORT			
3	F05010817R	TABELLE 2 CAR.SPORGENTI FR-D	WARNING BOARDS 2 FR-DE	TABLEAUX 2 AVERTISSEM. FR-DE		
4	F05010820R	CATARIFR.TONDO D60 ROSSO	ROUND REFLECTOR D.60 RED			
5	M04700563R	SUPPORTO LUCE D INGOMBRO	SUPPORT LIGHT OVERALL			
6	G18803050R	BOCCOLA 8,5X16X16 PL	BUSHING 8,5X16X16 PL			
7	F01420036R	ROS.M6 6,4X 18X1,5	WASHER M6 6,4X 18X1,5	RONDELLE M6 6,4X 18X1,5	SCHEIBEN M6 6,4X18X1,5U6593 ZN	ARANDELA M6 6,4X18X1,5U6593ZN
8	F05010833R	KIT LUCI POST.STRAD.ECCEZ.	KIT REAR ROAD LIGHTS M.EXCEP.		BELEUCHTUNG F R MIRKA	
9	F01020040R	VITE M6X1X40	SCREW M6X1X40	VIS M6X1X40	SCHRAUBE M6X1X40	TORNILLO M6X1X40
10	F01220011R	DADO M6X1	NUT M6X1	ECROU M6X1	MUTTER M6X1	TUERCA M6X1 D980 8 ZN
11	F01020404R	VITE M6X1X20	SCREW M6X1X20	VIS M6X1X20	SCHRAUBE M6X1X20	TORNILLO M6X1X20
12	F05010819R	CATARIFR.TONDO D60 GIALLO	ROUND REFLECTOR D.60 YELLOW	JAUNE R FLECTEUR ROUND	RUNDFLEKTOR GELB D60	REFLECTOR REDONDO AMARILLO

TAV.170

TABELLA SUPPLEMENTARE DC - DM - DM RAPIDO 3000-3500-4000
(PER IL MONTAGGIO VEDERE ANCHE TAV.140)

**CONSULTARE LIBRETTO USO E MANUTENZIONE*.*

*SUPPLEMENTARY ROAD PANEL FOR DC - DM - DM RAPIDO 3000-3500-4000
(FOR ASSEMBLY SEE ALSO TAB. 140)*

**MAKE REFERENCE TO THE OPERATION MANUAL*.*

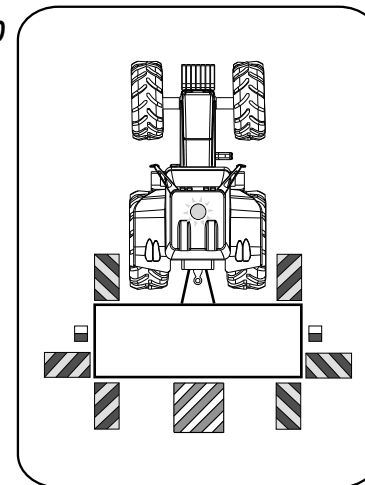
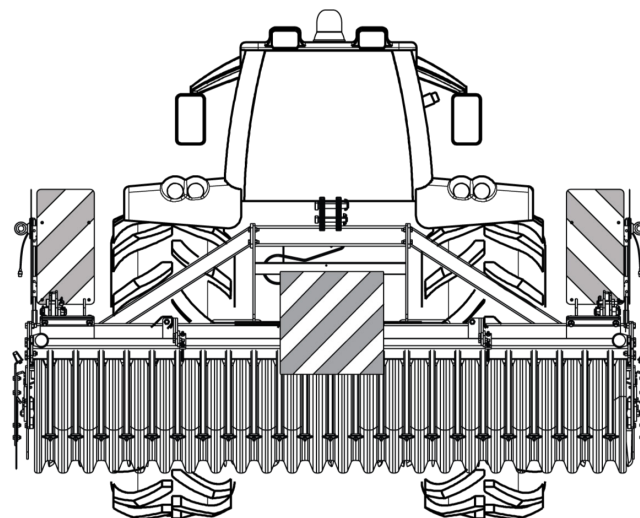
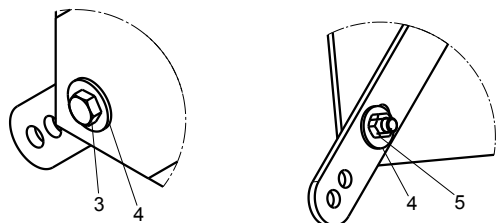
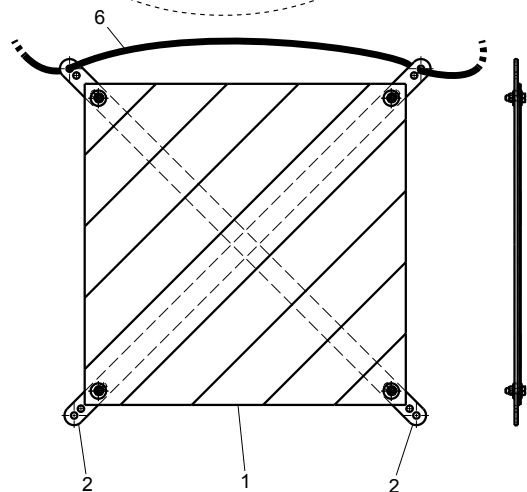
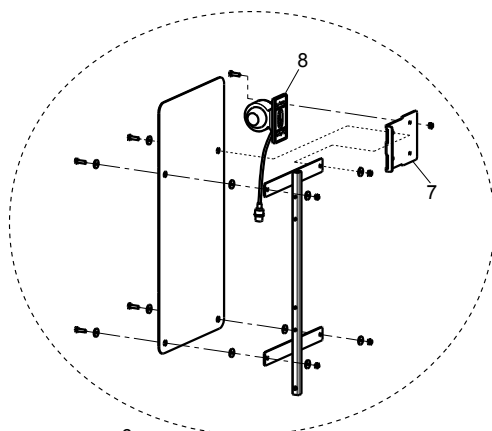

PER IL POSIZIONAMENTO FARE RIFERIMENTO ALLE
ISTRUZIONI ALLEGATE ALLA TABELLA.

*FOR POSITIONING MAKE REFERENCE TO THE INSTRUCTIONS
INCLUDED WITH THE ROAD PANELS.*



**KIT TABELLE STRADALI G99600032
ROAD TRANSPORT KIT G99600032**

TAV.170

Pos.	Cod.	Descrizione	Description	Benennung	Description	Description
1	F05011000R	TABELLA CAR. SPORGENTI 500X500	WARNING BOARD 500X500		WARN TAFEL 500X500	
2	M75400043R	SUPPORTO TAB.CAR.SPORG.500X500	SUPPORT FOR PANEL 500X500 IT		HALTER FUER PANEL 500X500 IT	
3	F01020440R	VITE M8X1,25X25	SCREW M8X1,25X25	VIS M8X1,25X25	SCHRAUBE M8X1,25X25	TORNILLO M8X1,25X25
4	F01420048R	ROS.M8 8,4X 24X 2	WASHER M8 8,4X 24X2	RONDELLE M8 8,4X 24X2	SCHEIBEN M8 8,4X24X 2 U6593 ZN	ARAND.M8 8,4X 24X 2 U6593 ZN
5	F01220022R	DADO M8X1,25	NUT M8X1,25	ECROU M8X1,25	MUTTER M8X1,25	TUERCA M8X 1,25 D980 8 ZN
6	F05150355R	CORDA ELAST. GANCIO D=8X800	ELASTIC CABLE HOOK D8 L800			
7	M04700562R	SUPPORTO LUCE D INGOMBRO	SUPPORT LIGHT OVERALL			
8	F05010847R	KIT LUCI PORT.POST.LAT.ECCEZ.	KIT REAR LIGHTS LATOUTSTANDING			

TAV.180

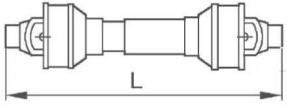
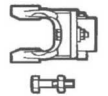
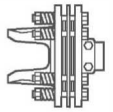
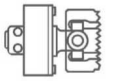
WALTERSCHEID

				
18 - F08011976 L= 965	--	X	--	--

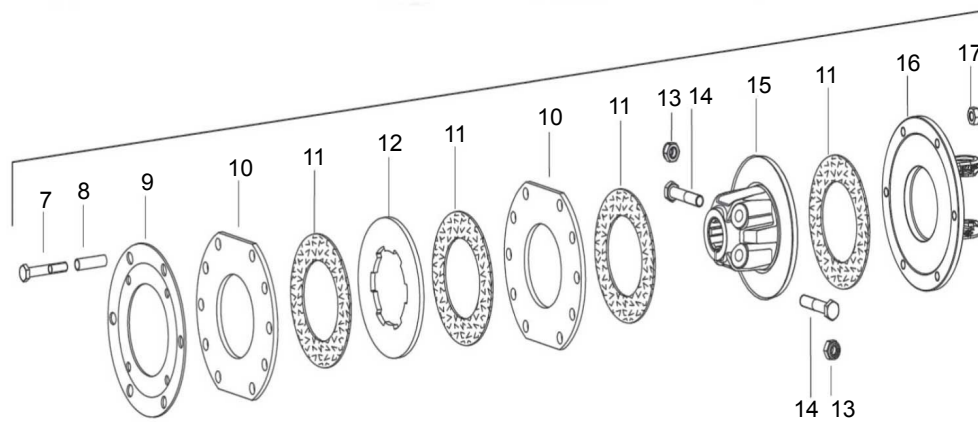
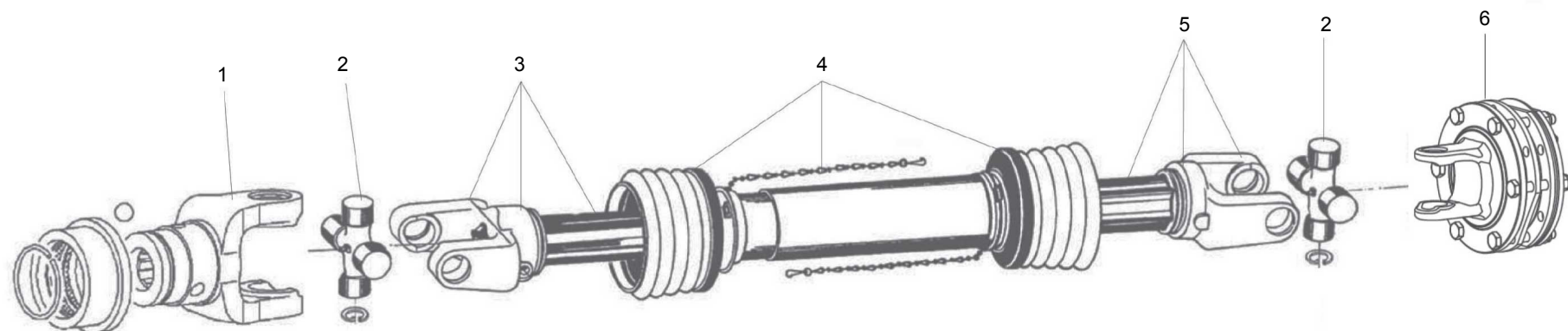
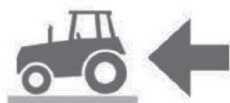

**CARDANO
CARDAN SHAFT**

TAV.180

Pos.	Cod.	Descrizione	Description	Benennung	Description	Descripcion
1	F08012328R	FORCELLA ATT.TRATTORE	TRACTOR ATTACHMENT FORK			
2	F08012331R	CROCIERA COMPLETA	COMPLETE CRUISE			
3	F08012332R	FORC. SP.EL. TUBO INT.	FORK EL-PIN INT.PIPE			
4	F08012327R	PROTEZIONE COMPLETA	COMPLETE PROTECTION			
5	F08012333R	FORC. SP.EL. TUBO EST.	FORK EL.PIN EST.PIPE			
6	F08012329R	FORCELLA A DISCHI M99599976	DISC FORK FOR M99599976			
7	F08012359R	VITE M10X65 DIN 931	SCREW M10X65 DIN 931			
8	F08012358R	TUBETTO	PIPE			
9	F08012365R	MOLLA A TAZZA	BELLEVILLE HUB			
10	F08012355R	DISCO FORCELLA	FORK DISC			
11	F08012353R	DISCO FORCELLA	FORK DISC			
12	F08012356R	DISCO FORCELLA	FORK DISC			
13	F08012362R	DADO M12 DIN985	NUT M12 DIN985			
14	F08012360R	VITE M12X65 DIN 931	SCREW M12X65 DIN 931			
15	F08012369R	MOZZO FORCELLA	FORK HUB			
16	F08012352R	FLANGIA FORCELLA	FORK FLANGE			
17	F08012361R	DADO M10 DIN934	NUT M10 DIN934			
18	F08011976R	CAR 50 WA 38Z6 FRZ 2100 L965	CAR 50 WA 38Z6 FRZ 2100 L965			

TAV.190

WALTERSCHEID

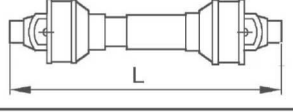
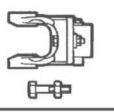
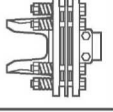
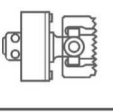
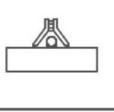
				
18 - F08011977 L= 1007	--	X	--	--

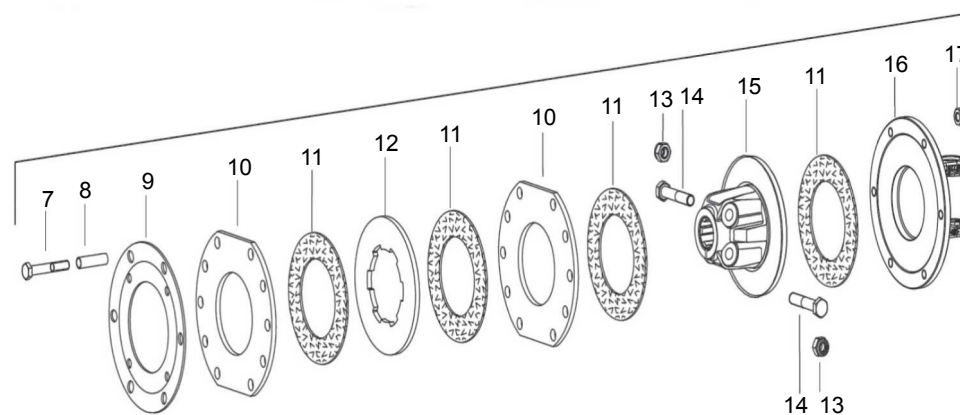
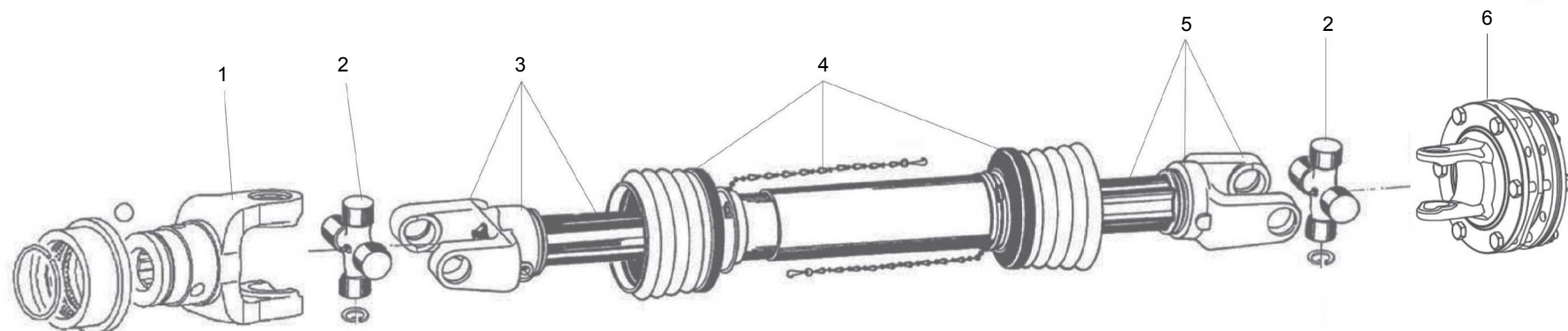
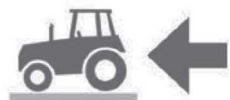





**CARDANO
CARDAN SHAFT**

TAV.190

Pos.	Cod.	Descrizione	Description	Benennung	Description	Descripcion
1	F08012336R	FORCELLA AT. TRATTORE M99599977	TRACTOR ATTACHMENT FORK			
2	F08012339R	CROCIERA COMPLETA	COMPLETE CRUISE			
3	F08012340R	FORC. SP.EL. TUBO INT.	FORK EL. PIN INT. PIPE			
4	F08012334R	PROTEZIONE COMPLETA M99599977	COMPLETE PROTECTION M99599977			
5	F08012341R	FORC. SP.EL. TUBO EST.	FORK EL. PIN EXT. PIPE			
6	F08012338R	FORCELLA A DISCHI	DISC FORK			
7	F08012359R	VITE M10X65 DIN 931	SCREW M10X65 DIN 931			
8	F08012358R	TUBETTO	PIPE			
9	F08012370R	MOLLA A TAZZA	BELLEVILLE SPRING			
10	F08012355R	DISCO FORCELLA	FORK DISC			
11	F08012353R	DISCO FORCELLA	FORK DISC			
12	F08012356R	DISCO FORCELLA	FORK DISC			
13	F08012362R	DADO M12 DIN985	NUT M12 DIN985			
14	F08012360R	VITE M12X65 DIN 931	SCREW M12X65 DIN 931			
15	F08012369R	MOZZO FORCELLA	FORK HUB			
16	F08012368R	FLANGIA FORCELLA	FORK FLANGE			
17	F08012361R	DADO M10 DIN934	NUT M10 DIN934			
18	F08011977R	CAR 60 WA 38Z6 FRZ 2100 L1007	CAR 60 WA 38Z6 FRZ 2100 L1007			

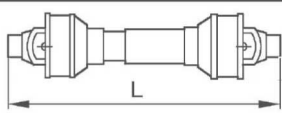
TAV.200

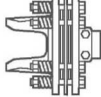
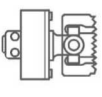
WALTERSCHEID

				
18 - F08011978 L= 1007	--	X	--	--

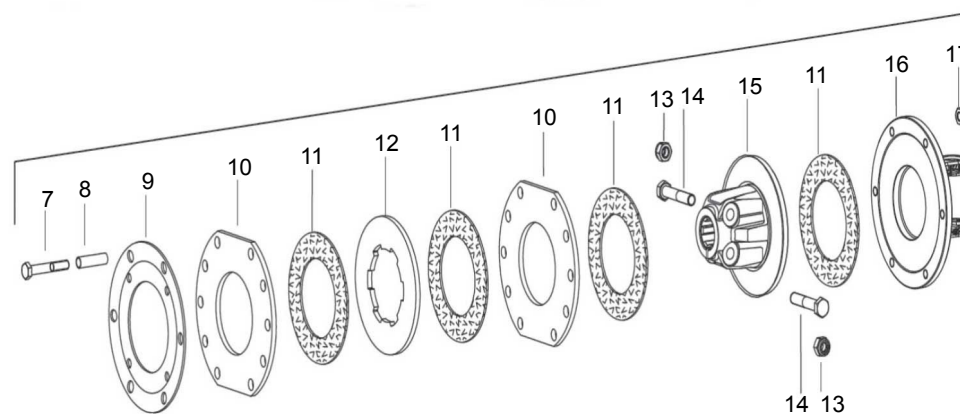
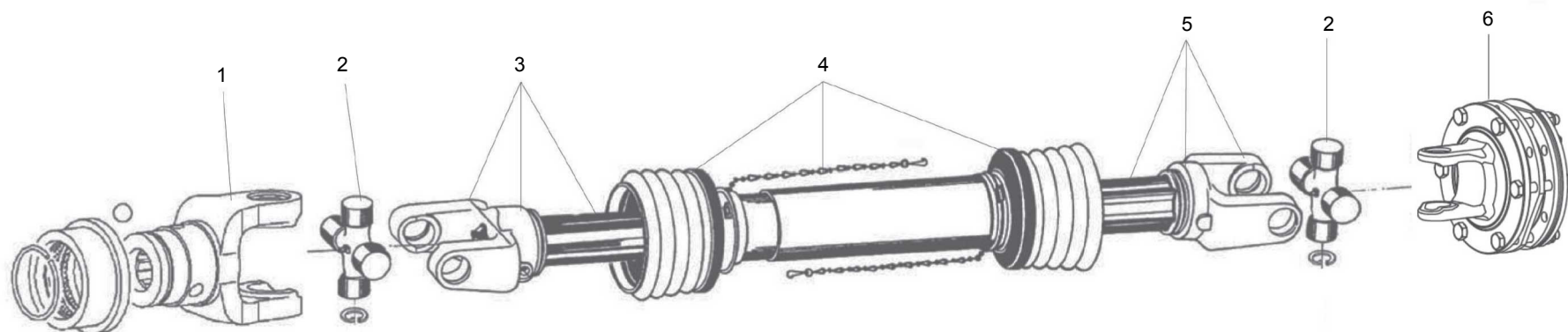
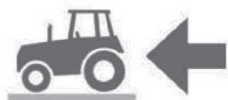

**CARDANO
CARDAN SHAFT**

TAV.200

Pos.	Cod.	Descrizione	Description	Benennung	Description	Descripcion
1	F08012337R	FORCELLA AT. TRATTORE M99599978	TRACTOR ATTACHMENT FORK			
2	F08012339R	CROCIERA COMPLETA	COMPLETE CRUISE			
3	F08012340R	FORC. SP.EL. TUBO INT.	FORK EL. PIN INT. PIPE			
4	F08012335R	PROTEZIONE COMPLETA M99599978	COMPLETE PROTECTION M99599978			
5	F08012341R	FORC. SP.EL. TUBO EST.	FORK EL. PIN EXT. PIPE			
6	F08012338R	FORCELLA A DISCHI	DISC FORK			
7	F08012359R	VITE M10X65 DIN 931	SCREW M10X65 DIN 931			
8	F08012358R	TUBETTO	PIPE			
9	F08012370R	MOLLA A TAZZA	BELLEVILLE SPRING			
10	F08012355R	DISCO FORCELLA	FORK DISC			
11	F08012353R	DISCO FORCELLA	FORK DISC			
12	F08012356R	DISCO FORCELLA	FORK DISC			
13	F08012362R	DADO M12 DIN985	NUT M12 DIN985			
14	F08012360R	VITE M12X65 DIN 931	SCREW M12X65 DIN 931			
15	F08012369R	MOZZO FORCELLA	FORK HUB			
16	F08012368R	FLANGIA FORCELLA	FORK FLANGE			
17	F08012361R	DADO M10 DIN934	NUT M10 DIN934			
18	F08011978R	CAR 60 WA 38Z21 FRZ 2100 L100	CAR 60 WA 38Z21 FRZ 2100 L100			

TAV.210

WALTERSCHEID

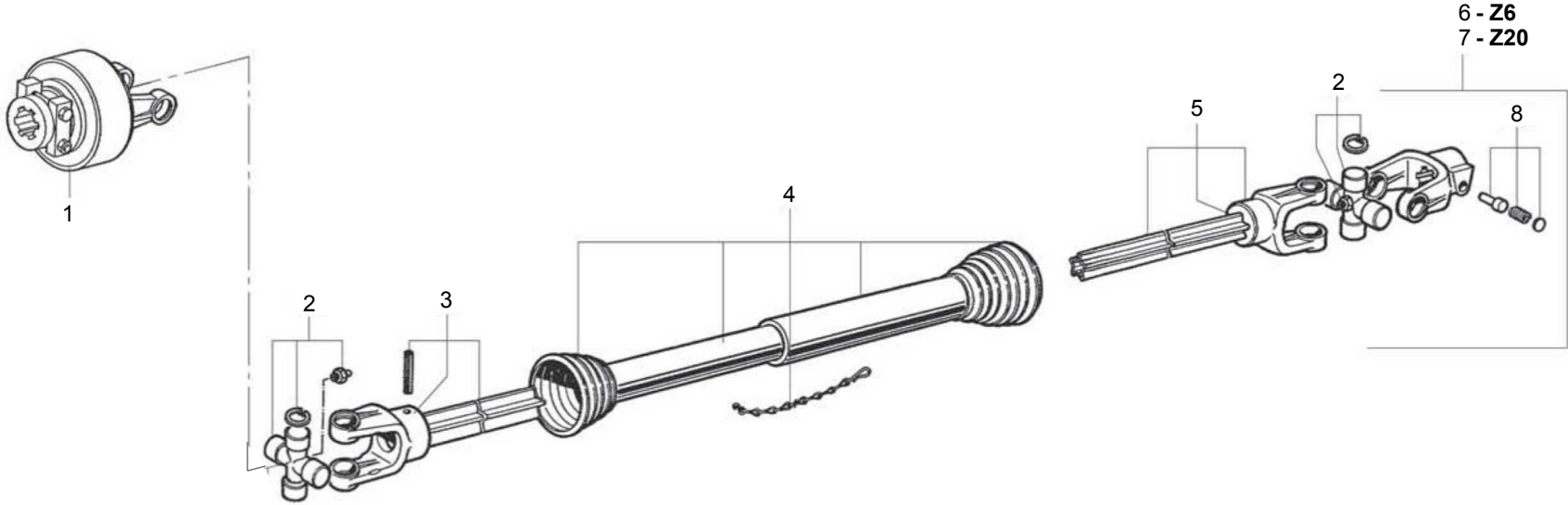



<p>9 - F08011802 L=965</p>	<p>--</p>	<p>--</p>	<p>x</p>	<p>OPTIONAL</p>

**CARDANO
CARDAN SHAFT**

TAV.210

Pos.	Cod.	Descrizione	Description	Benennung	Description	Description
1	F08011331R	LIMITATORE DI COPPIA K64 22RM	CLUTCH ASSY	EMBAYAGE COMPL.	KOMPL. KUPPLUNG	FRICCION COMPL.
2	F08010686R	CROCIERA COMPLETA	SPIDER ASSY	CROISIERE COMPL.	GELENKKREUZ KOMPL.	CRUCETA COMPLETA
3	F08010533R	FORCELLA CON TUBO INTERNO	FORK WITH INTERNAL PIPE	FOURCHE AVEC TUBE INTERIEUR	GABELST. INNENROHR	HORQUILLA TUBO INTERNO
4	F08010851R	PROTEZIONE COMPLETA	PROTECTION ASSY	PROTECTION COMPL.	KOMPL. SCHUTZ	PROTECCION COMPL.
5	F08010721R	FORCELLA TUBO ESTERNO	FORK WITH EXTERNAL PIPE	FOURCHE AVEC TUBE EXTERIEUR	GABELST. AUSSENROHR	HORQUILLA TUBO ESTERNO
6	F08010459R	FORCELLA COMP.PULS.-1 3 8 Z6	LINKAGE FORK-1 3 8 Z6	FOURCHE ATTELAGE-1 3 8 Z6	GABELSTUECK-1 3 8 Z6	HORQUILLA ATAQUE-1 3 8 Z6
7	F08010460R	FORCELLA 1 3 4 Z20 X W 2500	LINKAGE FORK-1 3 4 Z20	FOURCHE ATTELAGE-1 3 4 Z20	GABELSTUECK-1 3 4 Z20	HORQUILLA ATAQUE-1 3 4 Z20
8	F08011168R	339107 PULSANTE	YOKE PIN 339107	POUSSOIR COMPL.	DRUCKKNOPF KOMPL.	PULSADOR COMPL.
9	F08011802R	CAR.GKN CAMME 3 8 Z6 LT L965	PTO GKN CAMME 3 8 Z6 LT L96			

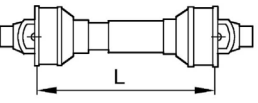
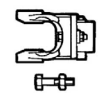
BONDIOLI - PAVESI

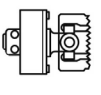
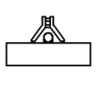
				
7 - F08011803	--	--	--	--

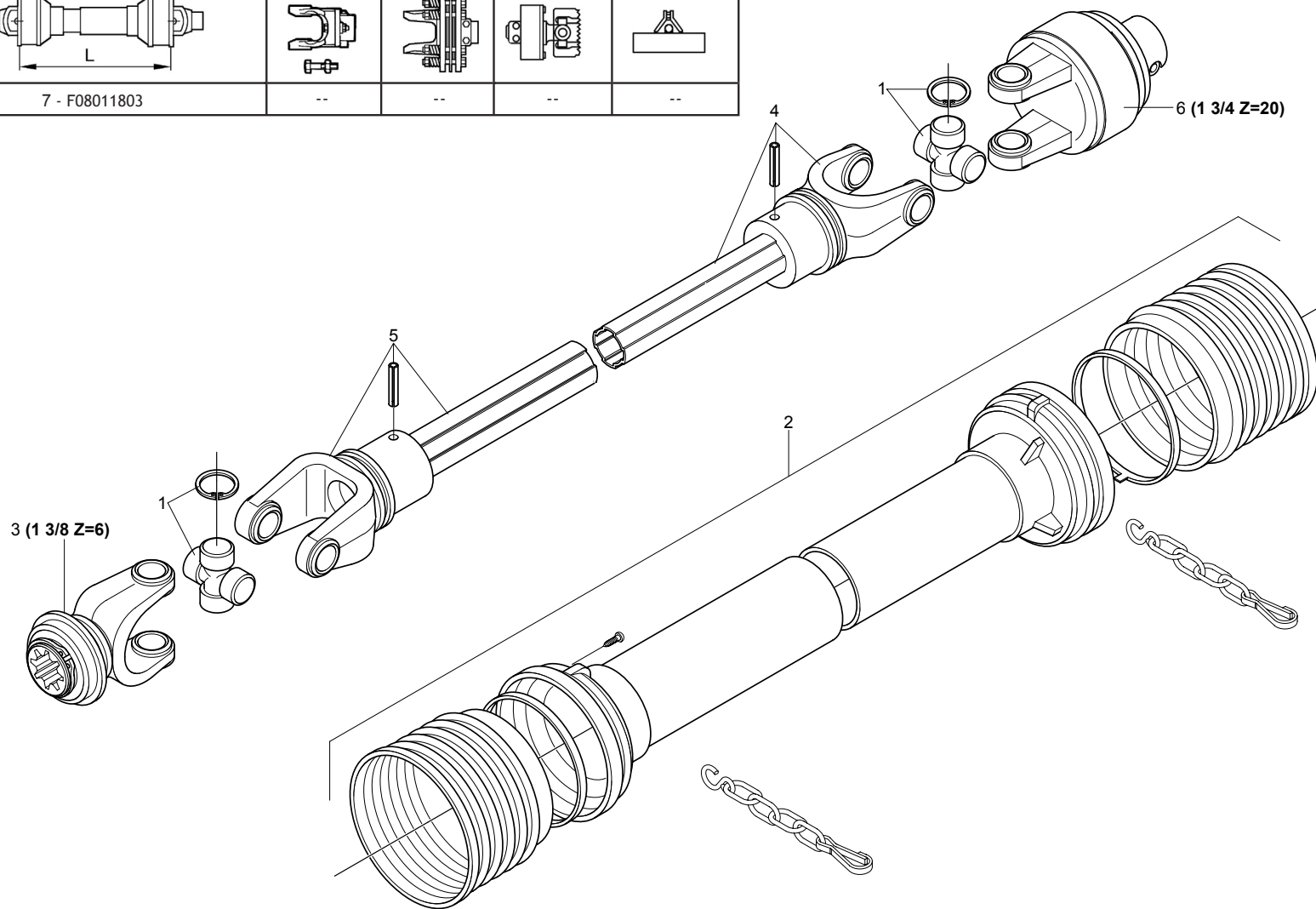





**CARDANO
CARDAN SHAFT**

TAV.220

Pos.	Cod.	Descrizione	Description	Benennung	Description	Description
1	F08010690R	CROCIERA COMPLETA	SPIDER ASSY	CROISILLON COMPL.	GELENKKREUZ KOMPL.	CRUCETA COMPLETA
2	F08010834R	PROT. COMPLETA BOS8	PROTECTION ASSY	PROTECTION COMPL.	KOMPL. SCHUTZ	PROTECCION COMPL.
3	F08013041R	FORC.COMPL. BO S8 3 8Z63	FORK		GABEL	
4	F08013014R	FORC.INT.S8 TUB 1000	FORK WITH INTERNAL PIPE	FOURCHE AVEC TUBE INTERIEUR	GABELST. INNENROHR	HORQUILLA TUBO INTERNO
5	F08010242R	FORC TUBO SP.GHIERA EST.S8	FORK EST. S8		GABEL EST. S8	
6	F08013040R	FRIZ.BO COMP.NOT 3 4 Z20 2500N	FRIZ.BO COMP.NOT 3 4 Z20 2500			
7	F08011803R	CAR 50 BO 38Z6 CAM 2500 L1063	PTO 50 BO 38Z6 CAM 2500 L1063		CAR 50 BO 38Z6 CAM 2500 L1063	

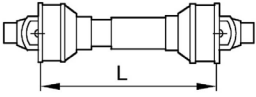
TAV.230

WALTERSCHEID

				
5 - F08011578 L=1185	--	--	X	--

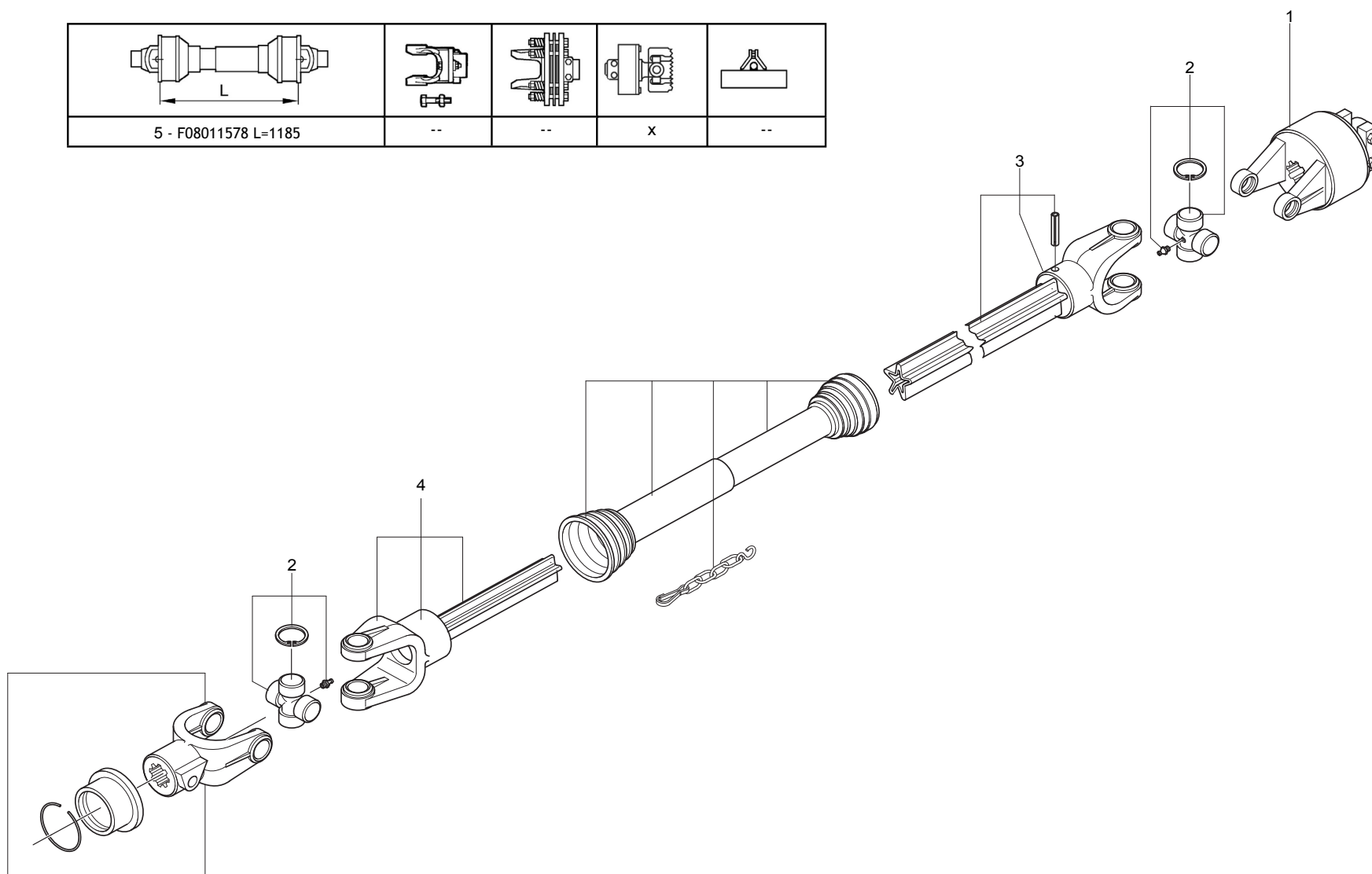





**CARDANO
CARDAN SHAFT**

TAV.230

Pos.	Cod.	Descrizione	Description	Benennung	Description	Description
1	F08011006R	FRIZIONE COMP.C.GKN K64 2R 29	CLUTCH ASSY	EMBAYAGE COMPL.	KOMPL. KUPPLUNG	FRICCION COMPL.
2	F08010670R	CROCIERA COMPLETA	SPIDER ASSY	CROISIERE COMPL.	GELENKKREUZ KOMPL.	CRUCETA COMPLETA
3	F08010196R	FORCELLA COMPL. ALBERO ESTERNO	FORK WITH EXTERNAL SHAFT	FOURCHE AVEC TUBE EXT.	GABELST. AUSSENROHR	HORQUILLA TUBO EXT.
4	F08010197R	FORCELLA COMPL. ALBERO INTERNO	FORK WITH INTERNAL PIPE	FOURCHE AVEC TUBE INTERIEUR	GABELST. INNENROHR	HORQUILLA TUBO INTERNO
5	F08011578R	CARD.GKN 180590	UNIVERSAL P T O SHAFT	ARBRE A CARDAN	GELENKWELLE	ARBOL CARDANICO

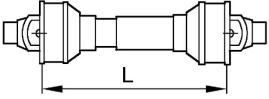
TAV.240

WALTERSCHEID

				
7 - F08011510	--	--	X	ORSO

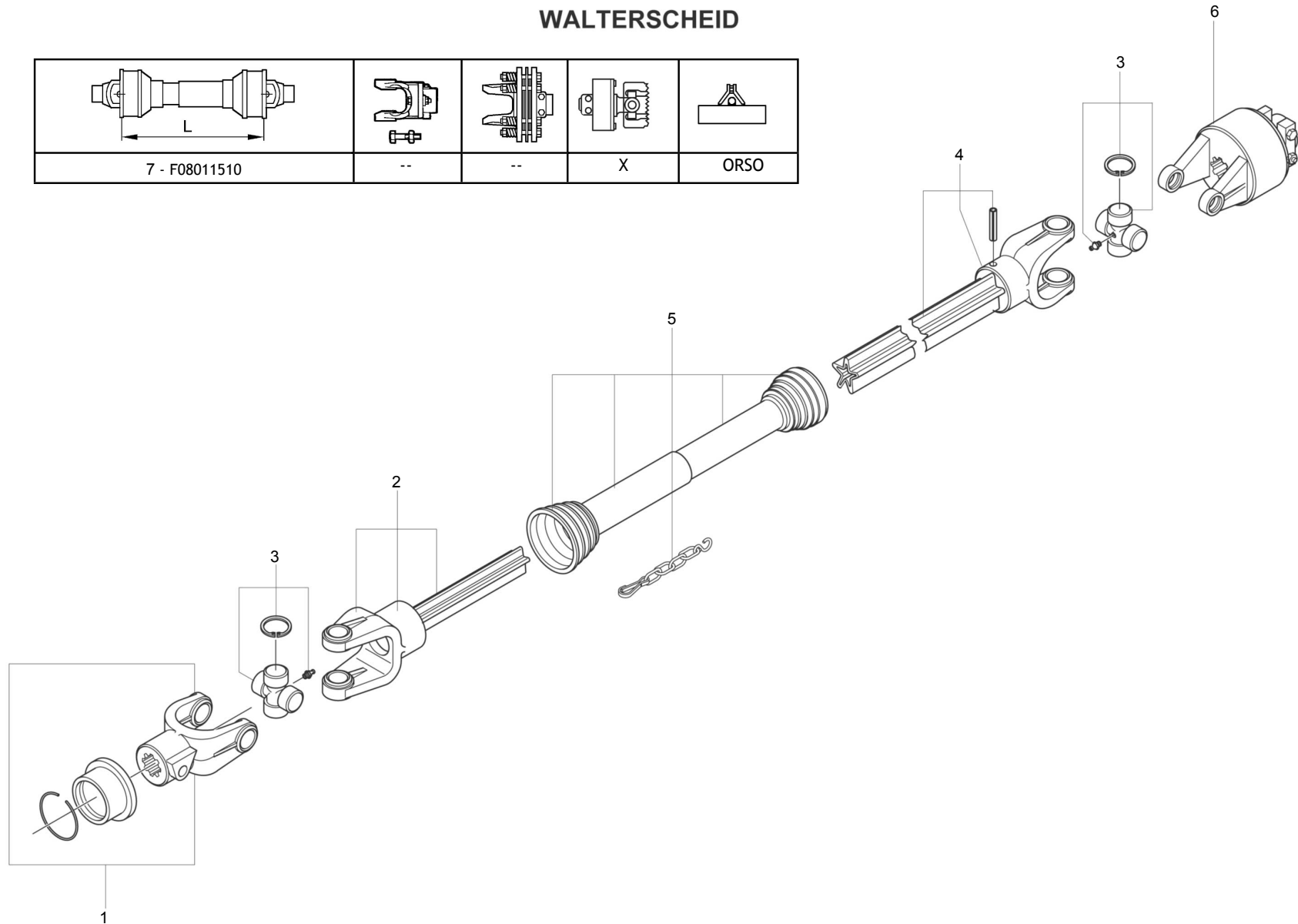

**CARDANO
CARDAN SHAFT**

TAV.240

Pos.	Cod.	Descrizione	Description	Benennung	Description	Description
1	F08010398R	FORCELLA 1 3 8 Z 21 2500	FORK 1 3 8 Z21 GKN W2500		GABEL	
2	F08010533R	FORCELLA CON TUBO INTERNO	FORK WITH INTERNAL PIPE	FOURCHE AVEC TUBE INTERIEUR	GABELST. INNENROHR	HORQUILLA TUBO INTERNO
3	F08010686R	CROCIERA COMPLETA	SPIDER ASSY	CROISIERE COMPL.	GELENKKREUZ KOMPL.	GRUCETA COMPLETA
4	F08010721R	FORCELLA TUBO ESTERNO	FORK WITH EXTERNAL PIPE	FOURCHE AVEC TUBE EXTERIEUR	GABELST. AUSSENROHR	HORQUILLA TUBO ESTERNO
5	F08010851R	PROTEZIONE COMPLETA	PROTECTION ASSY	PROTECTION COMPL.	KOMPL. SCHUTZ	PROTECCION COMPL.
6	F08011331R	LIMITATORE DI COPPIA K64 22RM	CLUTCH ASSY	EMBAYAGE COMPL.	KOMPL. KUPPLUNG	FRICCION COMPL.
7	F08011510R	CAR 50 WA 38Z21 CAM 2500 L965	PTO SHAFT 50 38Z21 CAM 2500		CAR 50 WA 38Z21 CAM 2500 L965	

MODELLO / MODEL	L. [mm]
DC 2500	2482
DC 3000 - DM 3000 - DM 3000 RAPIDO - DM 3000 RAPIDO COMBI	2974
DM 3500 - DM 3500 RAPIDO - DM 3500 RAPIDO COMBI	3466
DM 4000 - DM 4000 RAPIDO - DM 4000 RAPIDO COMBI	3958

L- RAPPRESENTA LA LARGHEZZA DEL RULLO E VIENE UTILIZZATA PER LA SELEZIONE DEI RICAMBI DEL RULLO, VEDERE IL CATALOGO RICAMBI RULLI ALLEGATO.

L- IT DESCRIBES THE ROLLER WIDTH, AND IT IS UTILIZED FOR THE SELECTION OF THE ROLLER SPARE PARTS SEE ROLLERS SPARE PARTS CATALOGUE ENCLOSED.

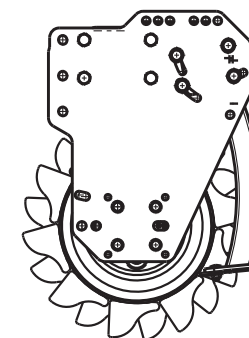
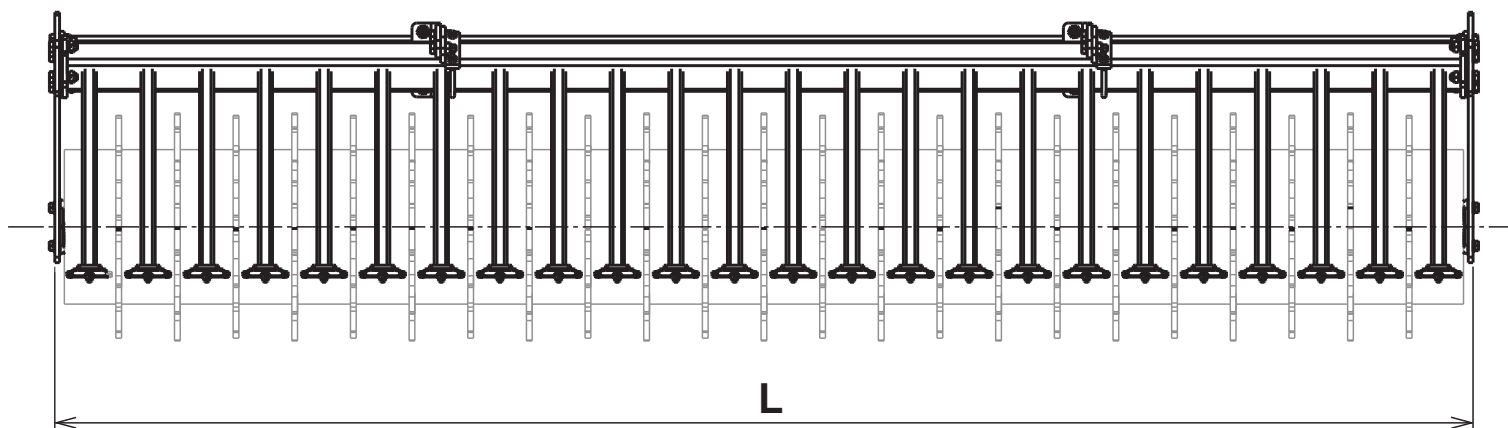

Pos.	Cod.	Descrizione	Description	Benennung	Description	Description

**USATE SEMPRE RICAMBI ORIGINALI
ALWAYS USE ORIGINAL SPARE PARTS
IMMER DIE ORIGINAL-ERSATZTEILE VERWENDEN
EMPLOYEZ TOUJOURS LES PIECES DE RECHANGE ORIGINALES
UTILIZAR SIEMPRE REPUESTOS ORIGINALES**



**Servizio Assistenza Tecnica - After Sales Service
Servizio Ricambi - Spare Parts Service**



maschio.com

DEALER:



MASCHIO GASPARDO SpA

Registered Office and Production Plant

Via Marcello, 73 - 35011 Campodarsego (Padova) - Italy

Tel. +39 049 9289810

Fax +39 049 9289900

info@maschio.com

www.maschionet.com

MASCHIO DEUTSCHLAND GMBH

Außere Nürnberger Straße 5

D - 91177 Thalmässing - Deutschland

Tel. +49 (0) 9173 79000

Fax +49 (0) 9173 790079

dialog@maschio.de

www.maschionet.de

MASCHIO FRANCE Sarl

1 rue Denis Papin ZA

F - 45240 La Ferte St. Aubin

France

Tel. +33 (0) 2.38.64.12.12

Fax +33 (0) 2.38.64.66.79

info@maschio.fr

ООО МАСКИО-ГАСПАРДО РУССИЯ

04130, Россия,

Волгоградская область,

г. Волжский, ул. Пушкина, 117 «б».

Тел.: +7 8443 203100

факс: +7 8443 203101

e-mail: info@maschio.ru

MASCHIO GASPARDO SpA

Production Plant

Via Mussons, 7 - 33075 Morsano al Tagliamento (PN) - Italy

Tel. +39 0434 695410

Fax +39 0434 695425

info@gaspardo.it

MASCHIO-GASPARDO USA Inc

120 North Scott Park Road

Eldridge, IA 52748 - USA

Ph. +1 563 2859937

Fax +1 563 2859938

info@maschio.us

MASCHIO-GASPARDO ROMANIA S.R.L.

Strada Înfrăţirii, F.N.

315100 Chisineu-Cris (Arad) -România

Tel. +40 257 307030

Fax +40 257 307040

info@maschio.ro

MASCHIO IBERICA S.L.

MASCHIO-GASPARDO POLAND

MASCHIO-GASPARDO UCRAINA

GASPARDO-MASCHIO TURCHIA

MASCHIO-GASPARDO CINA

MASCHIO-GASPARDO INDIA

