

GASPARDO

MASCHIO GASPARDO S.p.A.

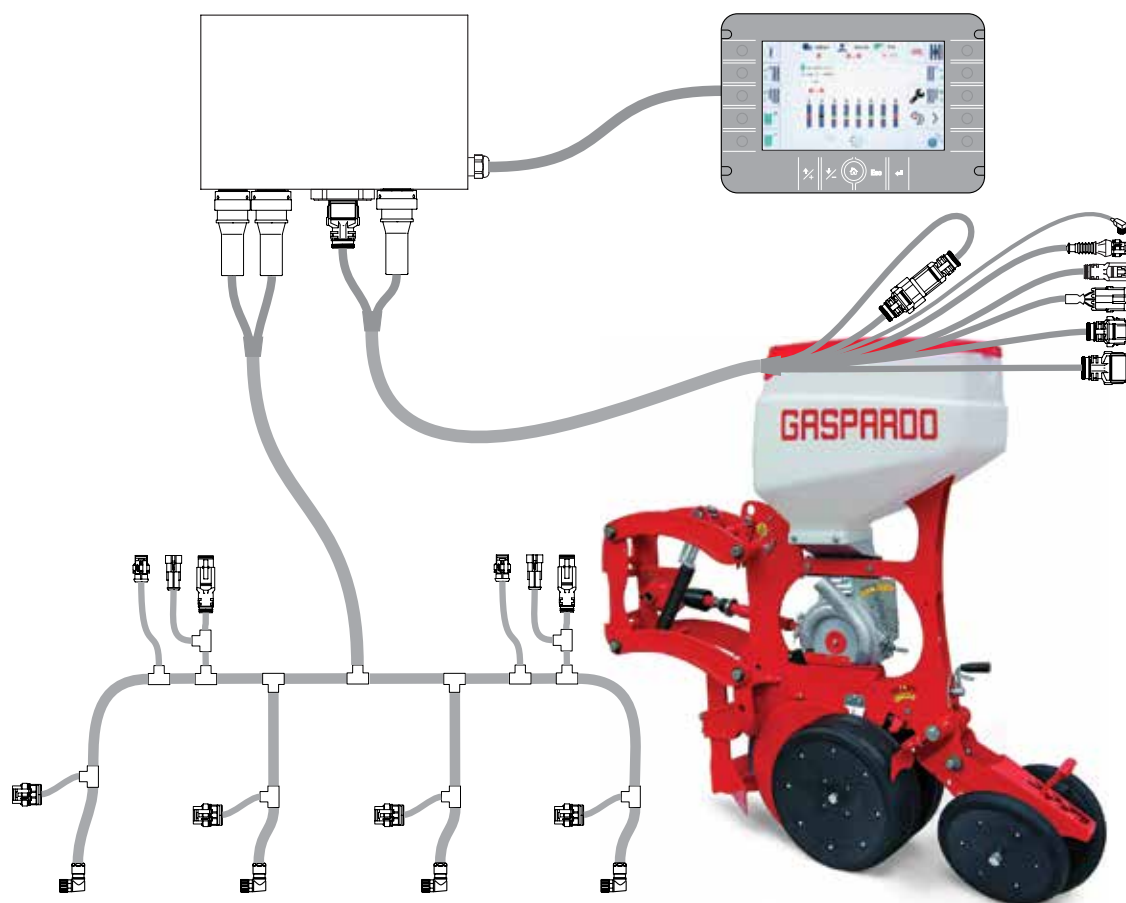

GENIUS MASTER

Precision Planter

«ISOTRONIC» and «SEED CONTROL» system

IT PARTI DI RICAMBIO

EN SPARE PARTS

PARTI DI RICAMBIO

Le ordinazioni delle parti di ricambio vanno fatte presso i nostri concessionari di zona e devono essere sempre corredate dalle seguenti indicazioni:

- **Tipo, modello e numero di matricola dell'attrezzatura.** Tali dati sono stampigliati nell'apposita targhetta di cui è dotata ogni attrezzatura.
- **Numero di codice della parte richiesta** rilevabile dal catalogo ricambi.
- Descrizione del particolare e quantità richiesta.
- **Mezzo di trasporto.** Nel caso questa voce non sia specificata, la Ditta Costruttrice, pur dedicando a questo servizio una particolare cura, non risponde di eventuali ritardi di spedizione dovuti a cause di forza maggiore.
Le spese di trasporto si intendono sempre a carico del destinatario. La merce viaggia a rischio e pericolo del committente anche se venduta franco destino.

N.B.: Il termine **Destro** o **Sinistro** indicato nelle descrizioni, va inteso guardando l'attrezzatura dal lato posteriore.

SPARE PARTS

Orders must be transmitted through our area dealers and should always include the following indications:

- **Type, model and serial number of the machine.** These data are punched on the data plate with which every implement is equipped.
- **Code number of the required spare part.** This will be found in the spare parts catalogue.
- **Description of the part and required quantity.**
- **Means of dispatch.** If this item is not indicated, the Manufacturer, while dedicating particular care to this service, shall not be held responsible for delays in delivery caused by cases of force majeure.
Transport expenses shall always be at the consignee's charge. The goods travel at the purchaser's risk and peril even when sold ex destination.

NOTE: The terms **Right** or **Left** indicated in the descriptions refer to the implement when viewed from the rear side.

PIECES DÉTACHÉES

Les ordres doivent être effectués auprès de nos concessionaires de zone en précisant les indications suivantes:

- **Type, modèle et numéro de série de la machine.** Ces données sont gravées sur la plaque d'identification de chaque outil.
- **Numéro de code de la pièce détachée** indiqué sur le catalogue des pièces détachées.
- **Description de la pièce et quantité requise.**
- **Numéro de plan.**
- **Moyen d'expédition.** Si cette rubrique n'est pas indiquée, le Constructeur, bien que soucieux de ce service, ne répond pas des retards d'expédition pour des causes de force majeure. Les frais de transport sont toujours à la charge du destinataire. La marchandise voyage aux risques et périls de l'acheteur même si vendue franco de port..

N.B.: Les références **(Dx) droit** et **(Sx) gauche** de la machine ou des parties de la même, est entendue, comme de la figure, en regardant la machine de derrière dans le sens de marche.

ERSATZTEILE

Die Bestellungen müssen bei unseren Gebietshändler aufgegeben werden. Bei der Bestellung sind stets die folgenden Angaben zu machen:

- **Typ, Modell und Serien-Nummer des Geräts.** Diese Daten stehen auf dem Typenschild, mit dem jedes Gerät versehen ist.
- **Artikel Nr. der erforderlichen Ersatzteile.** Diese stehen im Ersatzteil-Katalog.
- **Beschreibung des Ersatzteils und die erforderliche Stückzahl.**
- **Tafelnummer.**
- **Versandmittel.** Wenn dieser Punkt nicht spezifiziert wird, haftet die Herstellerfirma nicht für etwaigen Lieferverzug aufgrund höherer Gewalt, auch wenn er diesen Service besonders aufmerksam abwickelt. Die Frachtkosten gehen dagegen immer zu Lasten des Empfängers. Die Ware reist auf Gefahr und Risiko des Auftraggebers, auch wenn frei Haus Verkauft vereinbart worden ist.

N.B.: Die Merkzeichen **(Dx) rechts** und **(Sx) links** betreffen eine rückwärtige Aussicht der Maschine oder Teile von ihr (siehe Bild). Ausnahmen werden gezeigt.

RESPUESTOS

Los pedidos han de efectuarse en nuestros concesionarios de zona y deben incluir siempre las siguientes indicaciones:

- **Tipo, modelo y número de matrícula del equipo.** Dichos datos están impresos en la relativa placa presente en el equipo.
- **Número de código de la parte requerida** presente en el catálogo respuestas.
- **Descripción de la pieza y cantidad requerida.**
- **Numero de ilustración.**
- **Medio de transporte.** En caso que este ítem no esté especificado, el Fabricante, aún prestando la debidas consideraciones para este aspecto, no responde por eventuales retardos de env'o debidos a causas de fuerza mayor. Los gastos de transporte se consideran siempre a cargo del destinatario. La mercadería viaja bajo riesgo y peligro del comprador, incluso cuando se vende franco destino.

N.B.: La referencia **(Dx) derecha** o **(Sx) izquierda** de la máquina o de sus componentes, se entiende, como en la figura, mirando la máquina por la parte trasera. Se indicarán las excepciones.

ЗАПАСНЫЕ ЧАСТИ

Заказы на запасные части производятся у наших concessionaires зоны и всегда должны сопровождаться следующими указаниями:

- **Тип, модель и регистрационный номер оборудования.** Эти данные выбиты на соответствующей табличке, которой снабжено каждое оборудование.
- **Номер кода заказываемой запчасти** берется из каталога запчастей.
- **Описание детали и заказываемое количество.**
- **Транспортное средство.** В случае, если такая статья не будет четко оговорена, Фирма-Производитель, уделяя большое внимание этой услуге, снимает с себя ответственность за задержки в отправке, вызванные по причинам чрезвычайных обстоятельств.
Оплата транспортных расходов происходит за счет получателя. Ответственность за риск и опасность во время перевозки товара несет заказчик, даже если товар продан по франко-место назначения.

ВАЖНОЕ ЗАМЕЧАНИЕ: Термины **Правый-Левый**, указанные в описании, определяются, становясь лицом к оборудованию, с его задней стороны.

PIESE DE SCHIMB

Comandarea pieselor de schimb se va face prin intermediul concesionarilor din zonă și trebuie să fie întotdeauna însoțite de următoarele date:

- **Tipul, modelul și numărul de matricolă al utilajului.** Aceste date se găsesc pe plăcuța de identificare a fiecărui utilaj.
- **Numărul de cod al piesei de schimb cerute**, care se găsește în manual.
- Descrierea piesei de schimb și cantitatea cerută.
- **Mijloc de transport.** În cazul în care acesta nu este specificat, Firma Constructoare poate avea un regim special, nu răspunde de eventualele întârzieri de expediere datorate unor cauze de forță majoră.
Cheltuielile de transport sunt suportate de destinatar. Marfa este transportată pe riscul celui care efectuează comanda, chiar dacă marfa este vândută în condiții franco-destinatare.

NOTĂ: Termenul **(Dx) Dreapta** sau **(Sx) Stânga** a utilajului sau a părților acestuia, este privind utilajul din partea posterioară. Excepțiile vor fi indicate.

Nr. Tav.	Descrizione	Description	Pag.
TAV. 010	Configurazione «ISOTRONIC»	«ISOTRONIC» configuration	4
TAV. 020	Distributore semi versione «ISOTRONIC»	Seed distributor «ISOTRONIC» version	5
TAV. 030 (*)	Cablaggio sensori «ISOTRONIC»	Sensor cable «ISOTRONIC» version	6
TAV. 040 (**)	Cablaggio sensori «ISOTRONIC»	Sensor cable «ISOTRONIC» version	7
TAV. 050	Trasmissione Microgranulatore «ISOTRONIC»	Microgranulator transmission «ISOTRONIC»	8
TAV. 060	Encoder Monica-Magica/Maga «ISOTRONIC»	Encoder Monica-Magica/Maga «ISOTRONIC»	9
TAV. 070	Encoder Mirka-Renata/Marisa «ISOTRONIC»	Encoder Mirka-Renata/Marisa «ISOTRONIC»	10
TAV. 080	Encoder Scatola Cambio «ISOTRONIC»	Encoder Gearbox «ISOTRONIC»	11
TAV. 090 (*)	Configurazione «SEED CONTROL»	«SEED CONTROL» configuration	12
TAV. 100 (**)	Configurazione «SEED CONTROL»	«SEED CONTROL» configuration	13
TAV. 110	Monitor TERA	TERA monitor	14

(*) *Versione con funzioni idrauliche NON integrate. Version NOT integrated hydraulic function*

(**) *Versione CON funzioni idrauliche integrate. Version WITH integrated hydraulic function*

TAV. 010

«ISOTRONIC» version

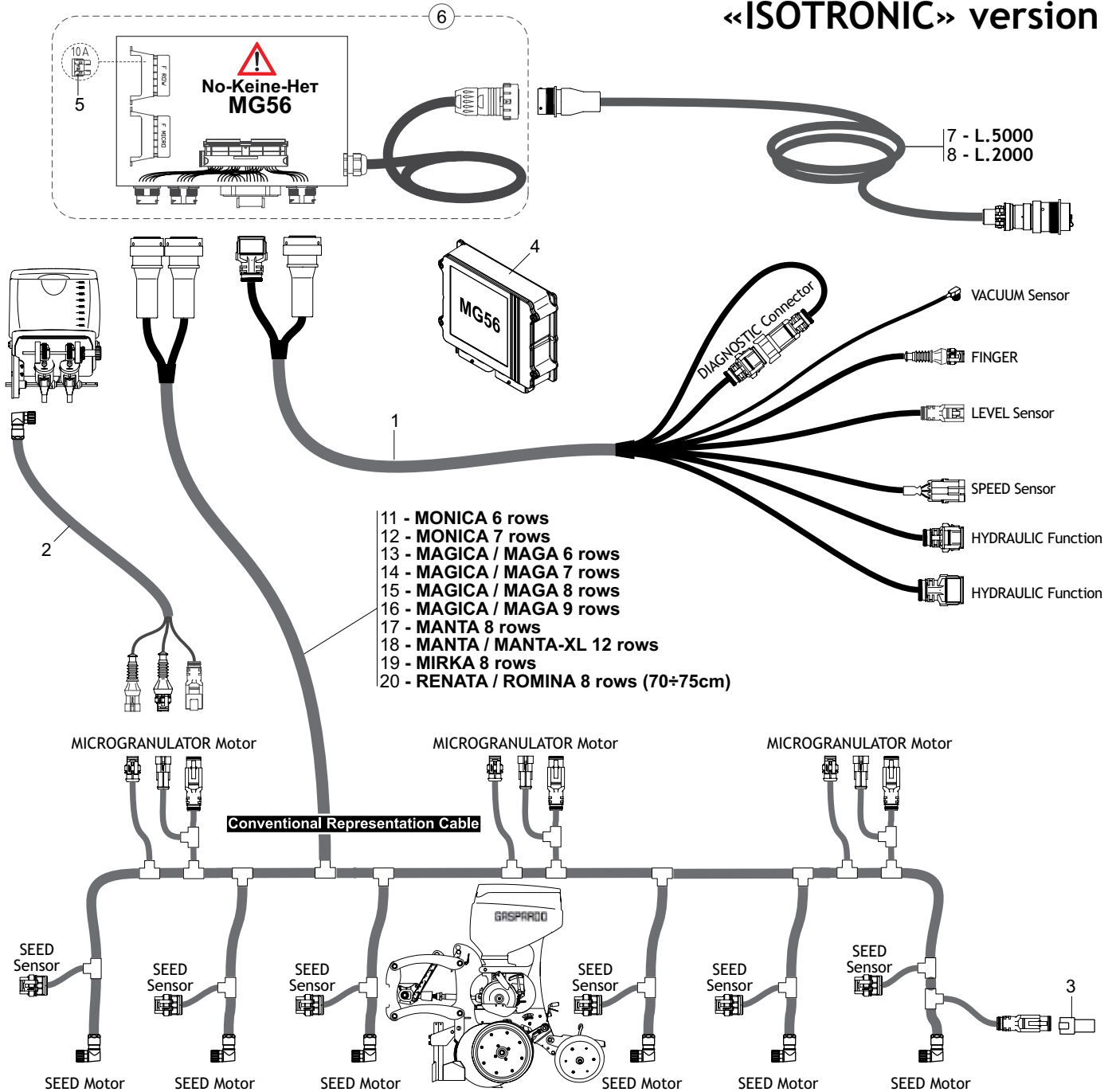

Pos.	Cod.	Description	Pos.	Cod.	Description
1	F05200586	CABL.SENSORS GM BOX	18	F05200711	CABL.MANTA IST 12R
2	F05200558	CABLE MICRO ELT.12V GM	19	F05200726	CABL.MIRKA IST 8R
3	GB5940150	CAN TERM 120 OHM	20	F05200701	CABL.RENATA IST 12V 8R ISO.
4	F05011614	ECU ASSY MG 56 GM ELECTRIC			
5	F05011415	FUSE 10A ATO			
6	F05011699	ELECTRIC BOX GM PE			
7	F05200320	M-F ISOBUS CABLE 5 METERS			
8	F05200285	M-F ISOBUS CABLE 2 METERS			
11	F05200703	CABL.MONICA IST 6R			
12	F05200704	CABL.MONICA IST 7R			
13	F05200706	CABL.MAGA-MAGICA IST 6R			
14	F05200707	CABL.MAGA-MAGICA IST 7R			
15	F05200708	CABL.MAGA-MAGICA IST 8R			
16	F05200709	CABL.MAGA-MAGICA IST 9R			
17	F05200710	CABL.MANTA IST 8R			

TAV. 020

«ISOTRONIC» version

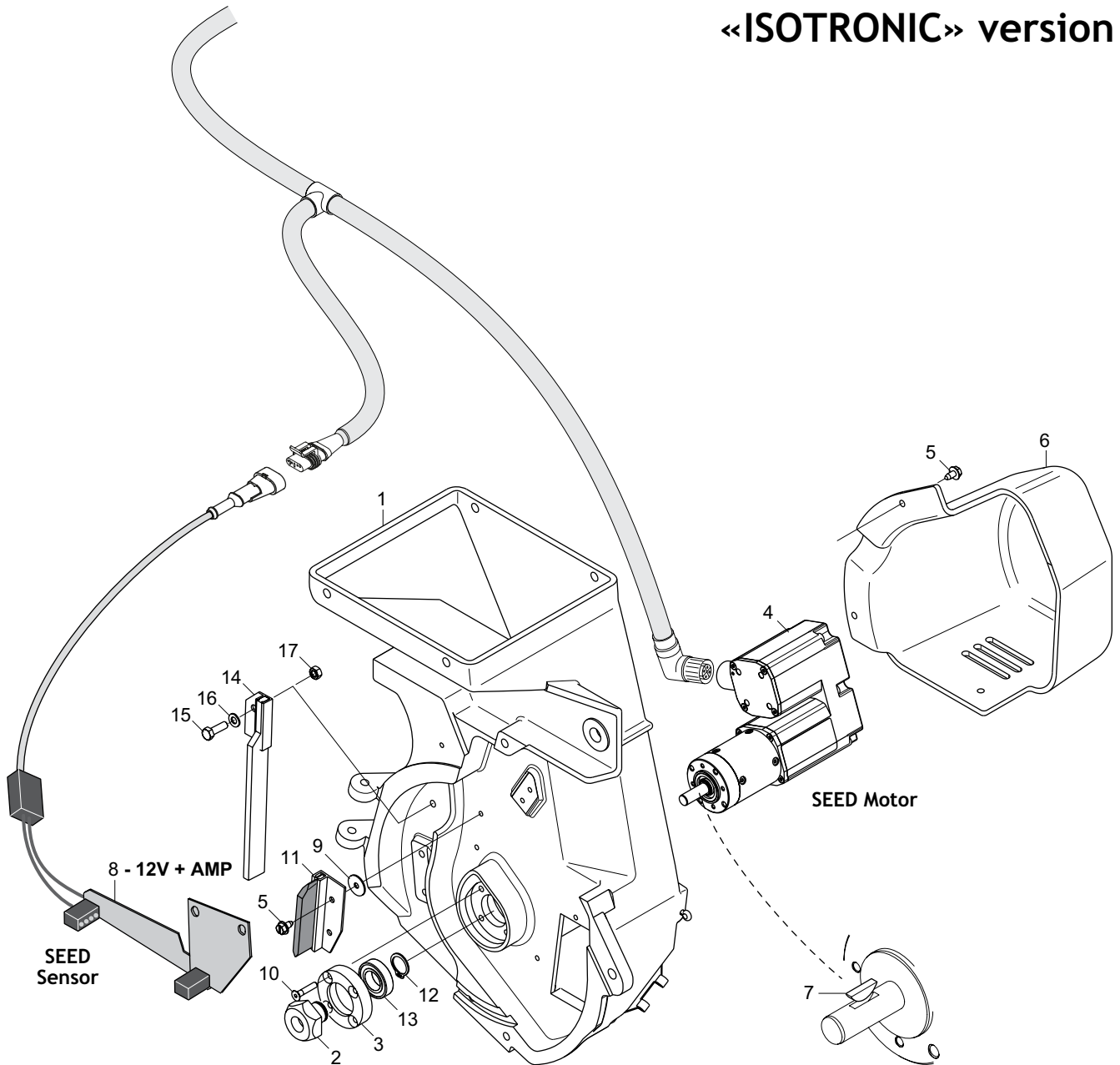

Pos.	Cod.	Description	Pos.	Cod.	Description
1	GA5221721	ELECTR.DISTRIBUTION CASING	17	F01200220	NUT M5X0,8 U5588 6.8ZN
2	GA5221731	TRANSMISSION AXLE			
3	GA5221741	BEARING-HOLDER FLANGE			
4	F05011793	RATIOMOTOR BRUSHLESS SHORT W/E			
5	F01070011	SCR. H4,2X1,41X9,5 U6950 4.8NI			
6	G19007720	SEED.UN.ELECTRIC ENGINE CASE			
7	F02150160	PARALLEL KEY 2X3,7X 10 U6606			
8	F05011459	SENSOR MC MTR 12V WITH AMP			
9	F01420011	FLAT WASHER 4-3X 16X1-5 6593 G			
10	F01030013	SCR. M 4X 0,7X 20 U5933 10.9ZD			
11	GA5223310	BRUSH SEEDING UNIT			
12	F02050034	ELASTIC RING DE 15X 1			
13	F04010306	BEARING d15 D28 B7 61902 2RS1			
14	GA5223940	THIN PLATE			
15	F01020378	SCR. M5X0,8X16 U5739 8.8ZN			
16	F01410023	WASHER M5 5,3X 10X 1 U6592			

TAV. 030

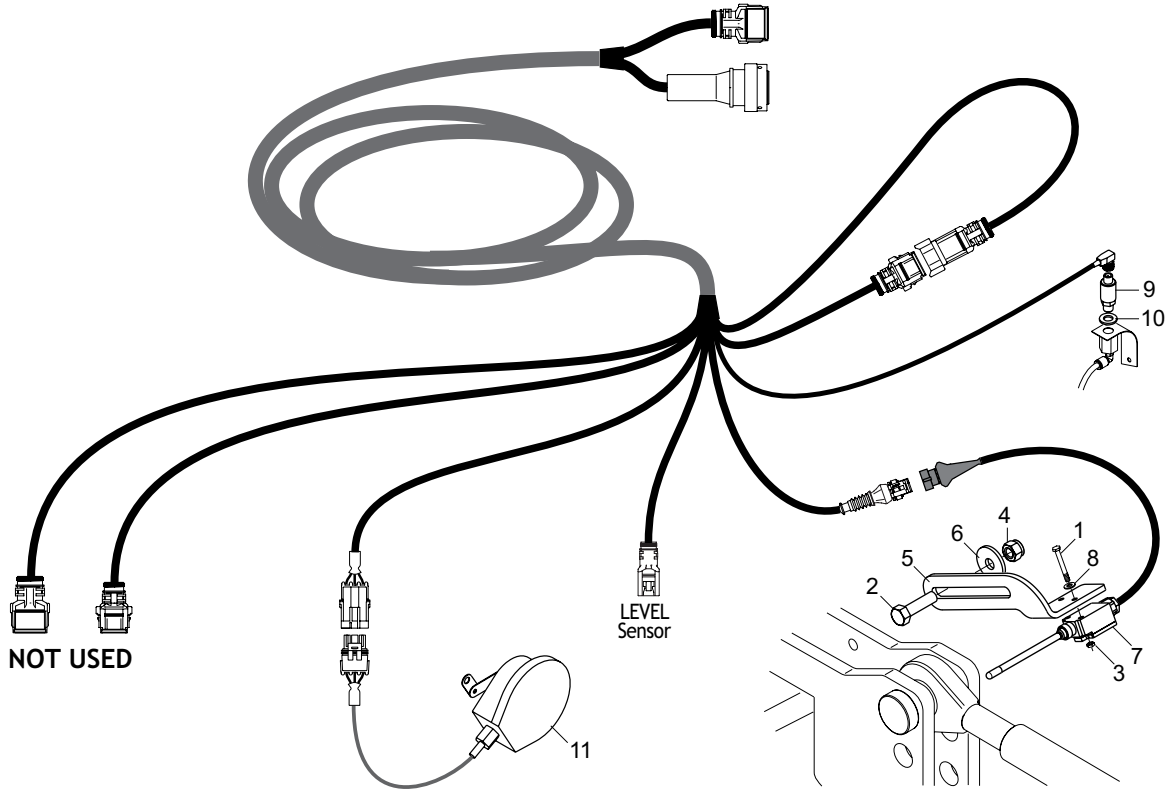
«ISOTRONIC» version NOT integrated hydraulic function

HYDRAULIC FUNCTIONS cable see Spare Parts book of the vacuum Precision Planters.

Pos.	Cod.	Description	Pos.	Cod.	Description
1	F01020024	SCR. M5X0,8X40 U5737 8.8ZN			
2	F01020521	SCR. M12X1,75X65 U5739 8.8ZN			
3	F01200220	NUT M5X0,8 U5588 6.8ZN			
4	F01230059	LOCK-NUT M12X1,75 D982 8ZN			
5	GA7912420	BLADE SUPPORT FINGER ZN			
6	G20970085	WASHER 40X4X13			
7	G17311430	FINGER WITH PIN			
8	F01420023	WASHER M5 5,3X 15X1,5 U6593			
9	F05011136	DEPRES.SENSOR -200MBAR 0,5-4,5			
10	F05150479	PRESSURE GAUGE REST WASHER			
11	F05010633	ENCODER DJ 360 IMP/RPM +CABLE			

TAV. 040

«ISOTRONIC» version WITH integrated hydraulic function

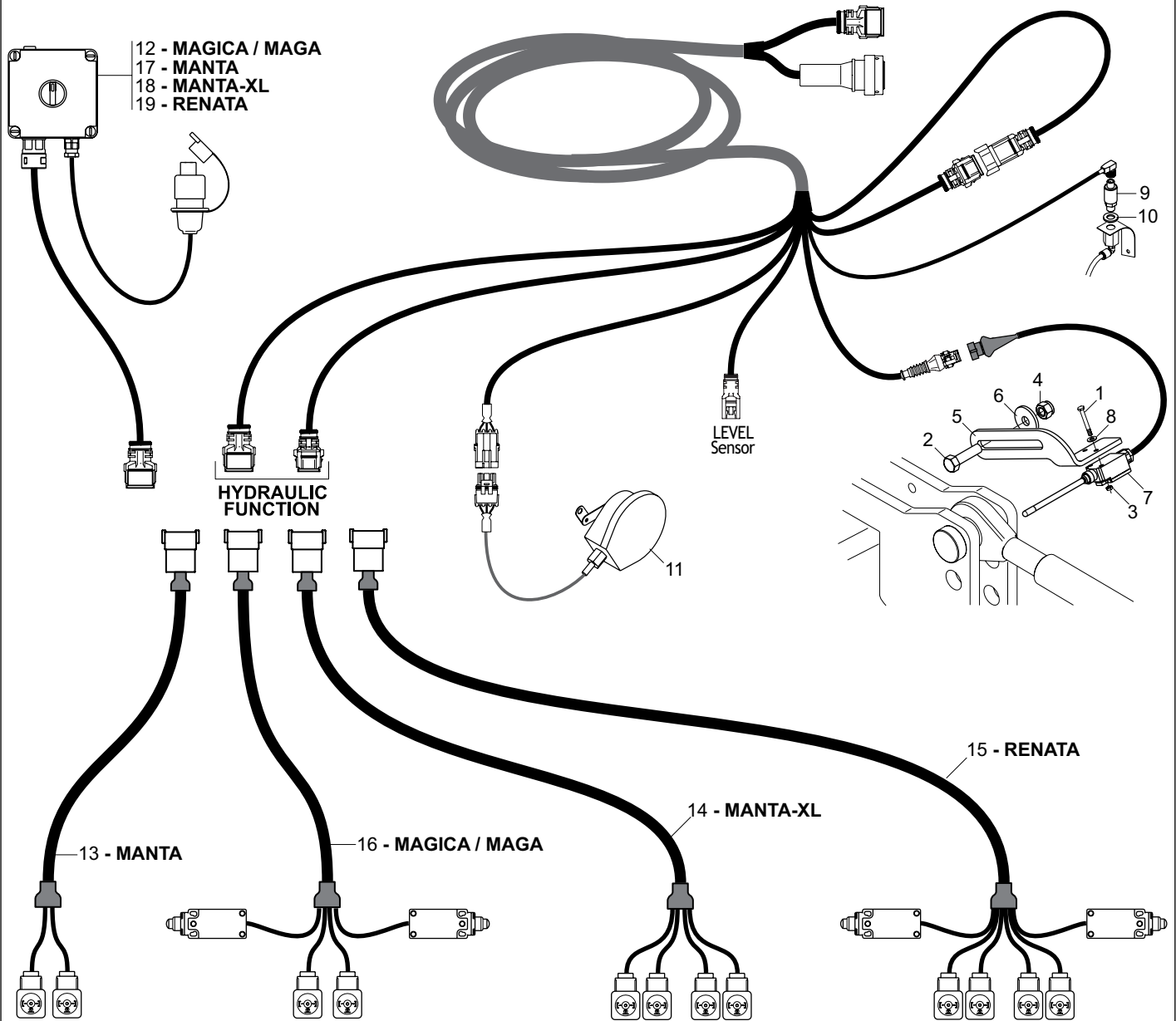

Pos.	Cod.	Description
1	F01020024	SCR. M5X0,8X40 U5737 8.8ZN
2	F01020521	SCR. M12X1,75X65 U5739 8.8ZN
3	F01200220	NUT M5X0,8 U5588 6.8ZN
4	F01230059	LOCK-NUT M12X1,75 D982 8ZN
5	GA7912420	BLADE SUPPORT FINGER ZN
6	G20970085	WASHER 40X4X13
7	G17311430	FINGER WITH PIN
8	F01420023	WASHER M5 5,3X 15X1,5 U6593
9	F05011136	DEPRES.SENSOR -200MBAR 0,5-4,5
10	F05150479	PRESSURE GAUGE REST WASHER
11	F05010633	ENCODER DJ 360 IMP/RPM +CABLE
12	F05011817	SHUNT BOX HYDR.COMMANDS
13	F05200404	CABLE 2 COM.EV.MAGICA G.M.
14	F05200367	CABLE 4 COMMANDS ELETTROVALVE
15	F05200753	CABL.EV.RENATA-MARISA G.M. >
16	F05200398	CABLE 2 COM.EV.MAGICA-MAGA G.M

Pos.	Cod.	Description
17	F05011936	BOX COM.HYDR. MANTA
18	F05011934	BOX COM.HYDR. MANTA XL
19	F05011935	BOX COM.HYDR. RENATA-MARISA

TAV. 050

«ISOTRONIC» version

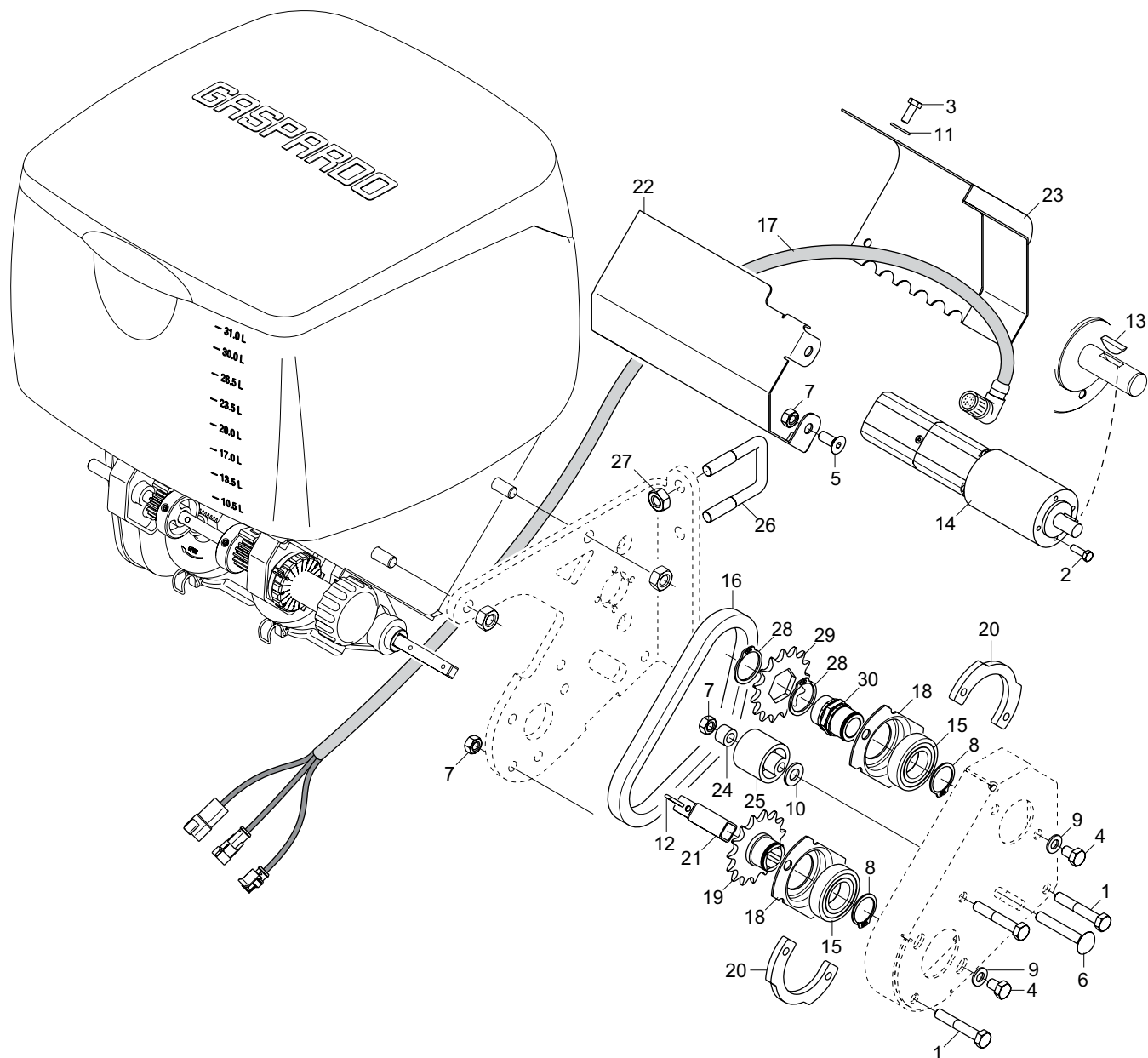

Pos.	Cod.	Description	Pos.	Cod.	Description
1	F01020072	SCR. M8X1,25X50 U5737 8.8ZN	17	F05200702	CABLE MICRO ELT. 2016
2	F01020378	SCR. M5X0,8X16 U5739 8.8ZN	18	G15725030	BEARING SUPPORT
3	F01020403	SCR. M6X1X16 U5739 8.8ZN	19	G15835470	ISO 08B-1 Z=15 PINION SQR16,4
4	F01020427	SCR. M8X1,25X12 U5739 8.8ZN	20	G14231510	COUNTERSUPPORT
5	F01030055	SCR. M8X1,25X20 U5933 10.9ZD	21	G14276440	MICRO SLEEVE L.55
6	F01060050	SCR. M8X1,25X55 U5732 4.6ZN	22	GA5275100	MICRO ELECTRIC ENGINE CASE
7	F01200244	NUT M8X1,25 U5588 6.8ZN	23	G17178020	MOTOR CASE
8	F02050101	SEEGER RING E. 25X1,2 7435 C70	24	G18801580	BUSH 8.5 X15 X10
9	F01410051	WASHER M8 8,4X17X1,6 U6592 ZN	25	G66248207	CHAIN TENSIONER
10	F01410064	WASHER M10 10,5X20X2 U6592 ZN	26	F20110706	U BOLT Q.B=35 M=10X1,5 L=60
11	F01420036	WASHER M6 6,4X 18X1,5 U6593 ZN	27	F01200270	NUT M10X1,5 U5588 6.8ZN
12	F02200162	SPLIT PIN 3 X20 1336 GALVAN.	28	F02050615	STOP RING 28 UNI 7435-75
13	F02150172	KEY 4X6,5X 16 U6606	29	G10522500	GEARB.RING Z15 1/2X3/16 ES27,2
14	F05011816	RATIOM.BRUSHL.SHORT BG45X15+P	30	G14231500	HUB CROWN
15	F04010135	BEARING D25 D47 B12 6005 2RS			
16	F06080138	CHAIN 1/2 ISO 084 36 LINKS			

TAV. 060

«ISOTRONIC» version

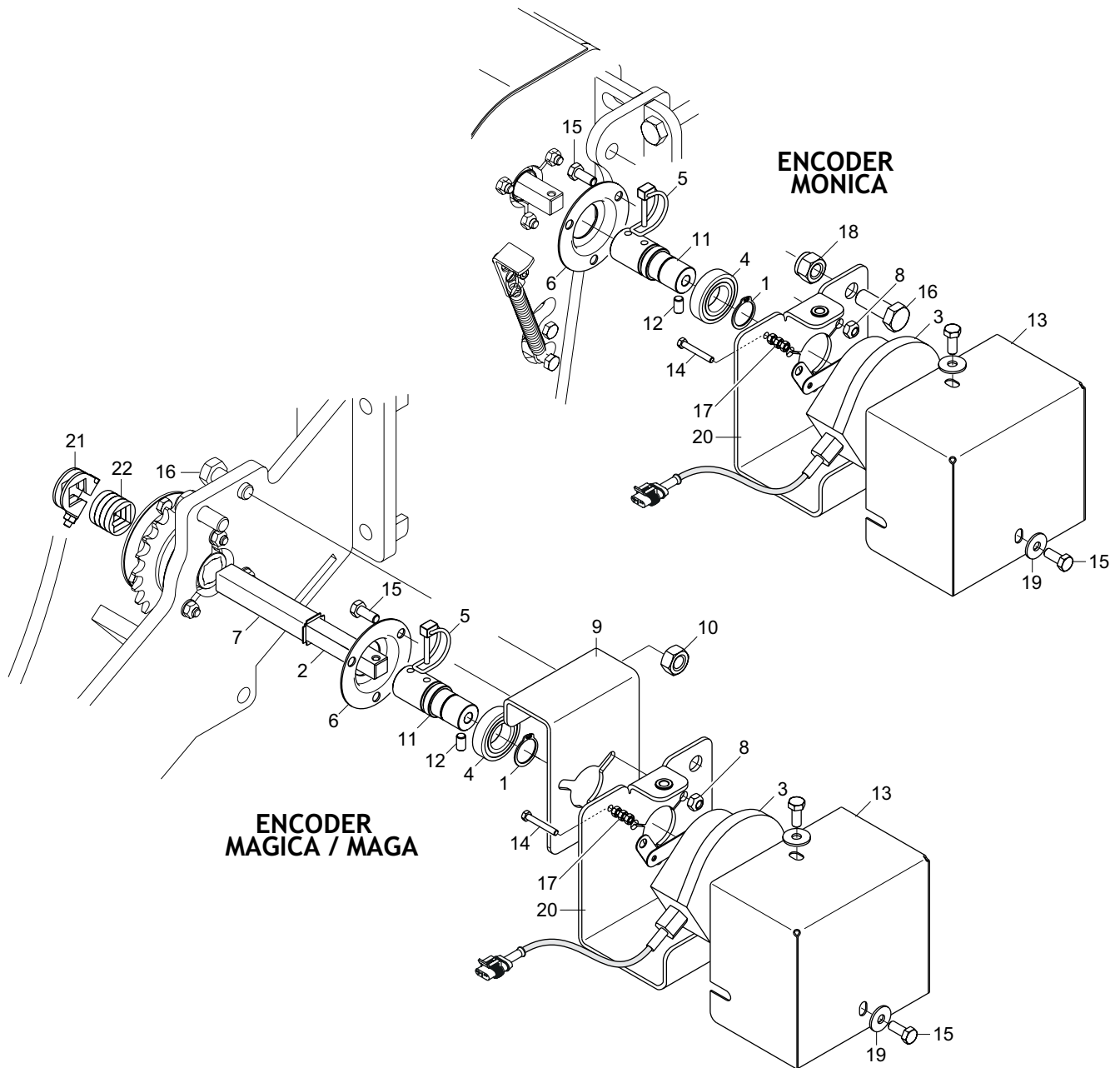

Pos.	Cod.	Description
1	F02050101	SEEGER RING E. 25X1,2 7435 C70
2	G15870380	TRANSMISSION AXLE L.120
3	F05010633	ENCODER DJ 360 IMP/RPM +CABLE
4	F04010135	BEARING D25 D47 B12 6005 2RS
5	F02200595	PIN X GEAR
6	G22230094	BEARING SUPPORT
7	G16621071	TUBE Q. 20X 1X 117 INOX
8	F01220022	NUT M8X1,25 D980 8ZN
9	G17132940	ENCODER BOX SUPPORT
10	F01200306	NUT M14X2 U5588 6.8ZN
11	G14231480	GALV.SHAFT ENCODER ASS.
12	F01050038	SCR. M8X1,25X4 U5923 8.8BR
13	G17116170	CASE ENCODER
14	F01020384	SCR. M5X0,8X35 U5739 8.8ZN
15	F01020436	SCR. M8X1,25X20 U5739 8.8ZN
16	F01020544	SCR. M14X2X40 U5739 8.8ZN
17	F01200220	NUT M5X0,8 U5588 6.8ZN

Pos.	Cod.	Description
18	F01230073	SELF LOCK NUT M14X2 D982 8ZN
19	F01420048	WASHER M8 8,4X 24X2 U6593 ZN
20	G17116150	TRANSM.SUPPORT ENCODER
21	G17131370	LOCK PLATE Q.20 COMPLETE
22	G17732240	WASHER 32XQ.20,5X6 ZN

TAV. 070

«ISOTRONIC» version

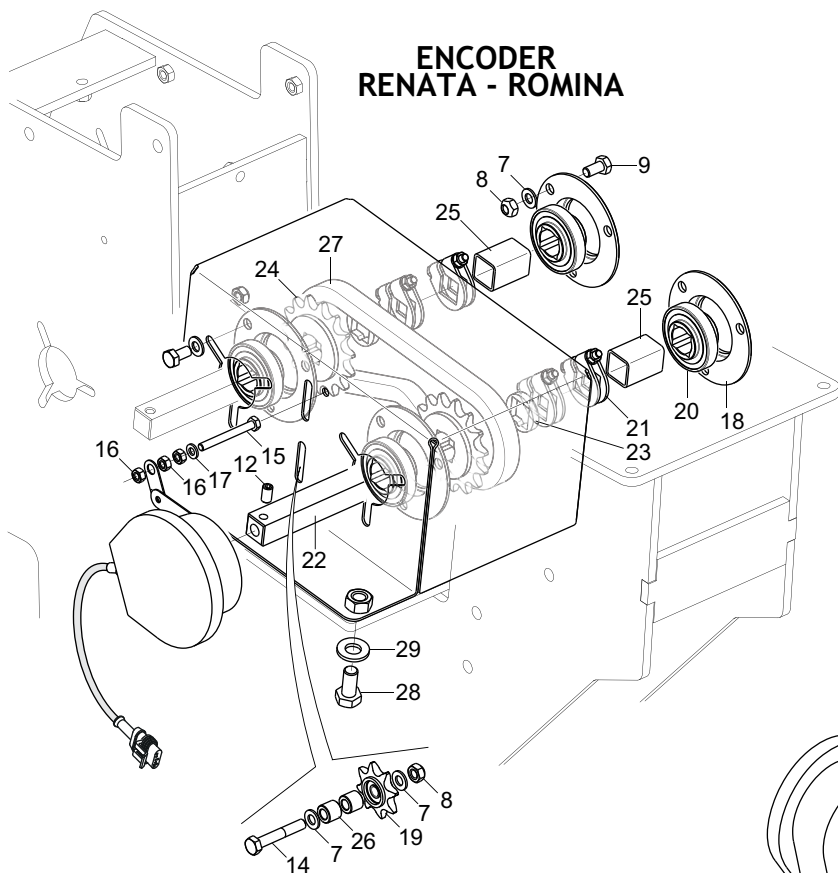
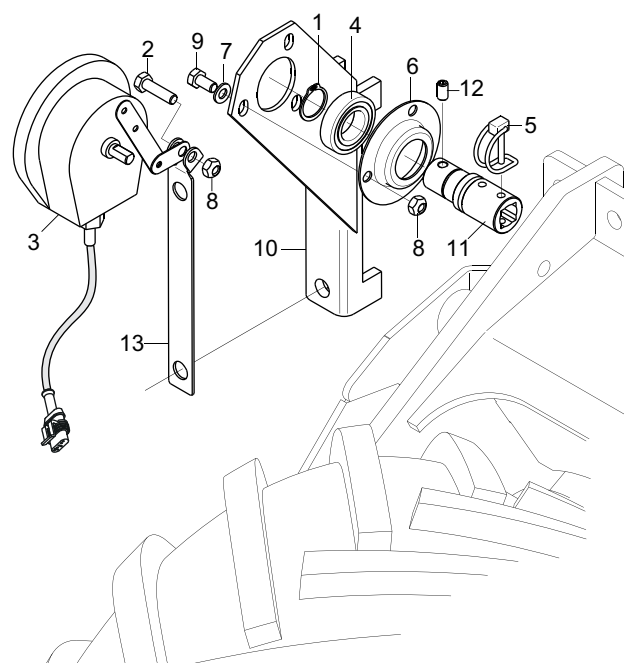
ENCODER
RENATA - ROMINAENCODER
MIRKA

Pos.	Cod.	Description
1	F02050101	SEEGER RING E. 25X1,2 7435 C70
2	F01020445	SCR. M8X1,25X30 U5739 8.8ZN
3	F05010633	ENCODER DJ 360 IMP/RPM +CABLE
4	F04010135	BEARING D25 D47 B12 6005 2RS
5	F02200595	PIN X GEAR
6	G22230094	BEARING SUPPORT
7	F01410051	WASHER M8 8,4X17X1,6 U6592 ZN
8	F01220022	NUT M8X1,25 D980 8ZN
9	F01020432	SCR. M8X1,25X16 U5739 8.8ZN
10	G15470381	TRANSM. SUPPORT FOR PIPE 150
11	G14231480	GALV.SHAFT ENCODER ASS.
12	F01050038	SCR. M8X1,25X4 U5923 8.8BR
13	G14231460	ENCODER ANTI-ROTATION
14	F01020072	SCR. M8X1,25X50 U5737 8.8ZN
15	F01020416	SCR. M6X1X55 U5739 8.8ZN
16	F01200232	NUT M6X1 U5588 6.8ZN
17	F01410037	WASHER M6 6,4X12,5X1,6 U6592ZN

Pos.	Cod.	Description
18	G22500092	BEARING SUPPORT
19	G16630790	GEAR Z8 5/8X3/8 CHAIN
20	G16631040	BEARING D35-55 B10 61907 20,5
21	G17131370	LOCK PLATE Q.20 COMPLETE
22	G17632650	TRANSMISS.AXLE L. 265 SQ.20
23	G17732240	WASHER 32XQ.20,5X6 ZN
24	G17732540	PINION Z15 5/8-3/8 SQ.20,4 ZN
25	G17733430	SQ.TUBE 25X 2X 37,5 IX
26	G18801880	BUSHING 8,25 X15 X13 ZN
27	F06080258	CHAIN 5/8 ASA 50 L 36 LINKS
28	F01020506	SCR. M12X1,75X20 U5739 8.8ZN
29	F01410076	WASHER 12 13X 24X2,5 U6592 ZN

TAV. 080

«ISOTRONIC» version

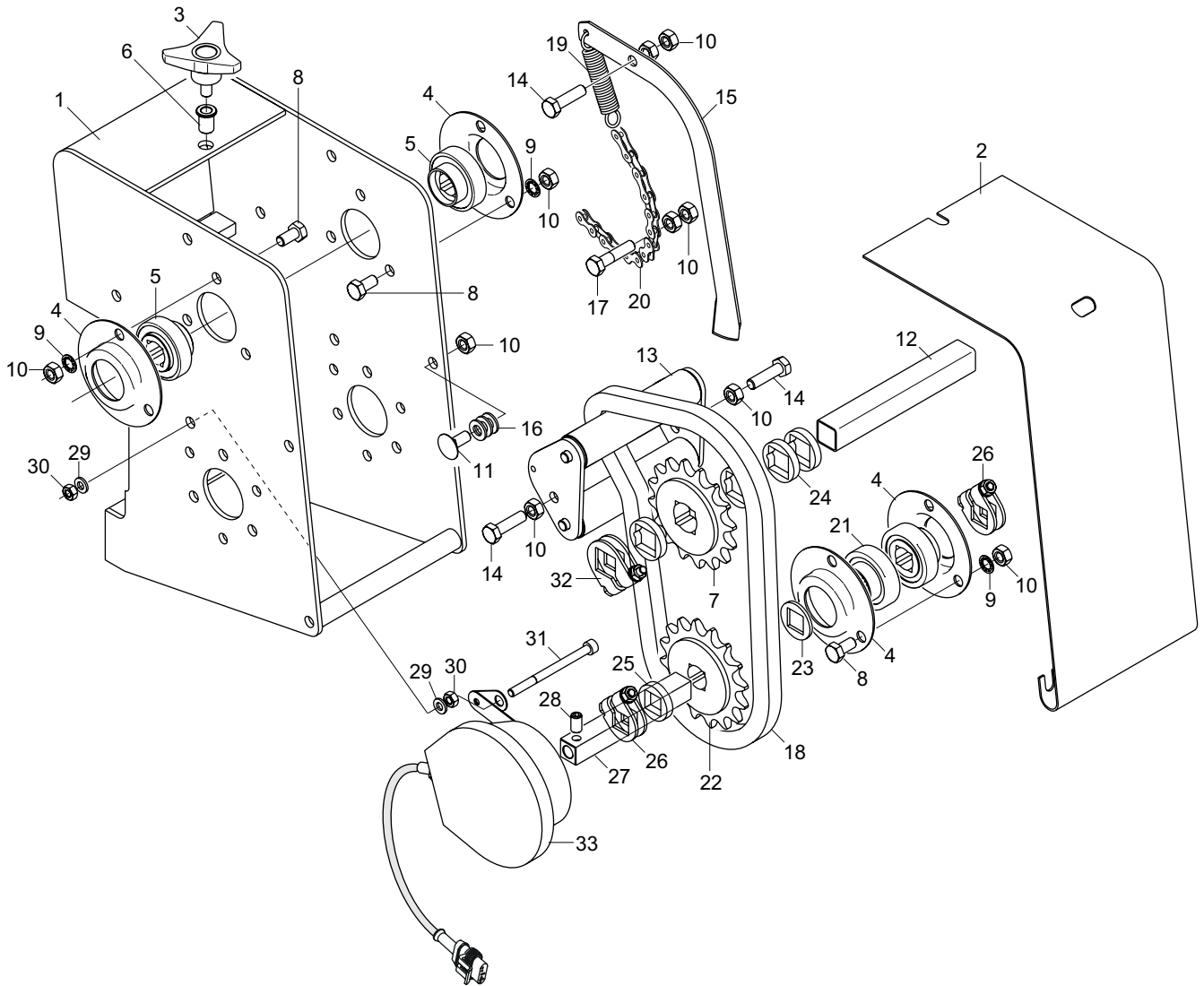

Pos.	Cod.	Description	Pos.	Cod.	Description
1	G15430292	GEARBOX Q.150	18	F06080230	CHAIN 5/8 ASA 50 L 46 LINKS
2	G15430711	GEAR COVER	19	G18902970	GALVAN. GEAR TRACT. SPRING SP
3	F06220018	3-LOBE HANDWHEEL D.65-M8X15	20	F06080008	CHAIN 1/2 ISO 083 16 LINKS
4	G22230094	BEARING SUPPORT	21	G10538350	SQUARE HOLE BEARING
5	G14830390	SQUARE-HOLED BEARING	22	G16630400	PINION Z-16 ZN.
6	F02250683	CYLINDRICAL NUT 8 TC 40	23	G18701650	WASHER 16,5X30X2,5 SQ.HOLE GAL
7	G17732210	PINION Z16 5/8-3/8 SQ.20,4 ZN	24	G17732240	WASHER 32XQ.20,5X6 ZN
8	F01020432	SCR. M8X1,25X16 U5739 8.8ZN	25	G66248218	MAN. SPR. SPACER WASHER
9	F01430059	WASHER M8 8,4X15X0,8 U8842J ZN	26	G22505085	PLATE AXLE STOP
10	F01200244	NUT M8X1,25 U5588 6.8ZN	27	G15232380	TRANSMISS.AXLE L.120 ENCODER
11	F01060040	SCR. M8X1,25X20 U5732 4.6ZG	28	F01050038	SCR. M8X1,25X4 U5923 8.8BR
12	G15430340	GEAR SPINDLE L.144	29	F01410037	WASHER M6 6,4X12,5X1,6 U6592ZN
13	G15430321	CHAIN STRETCHER ROLLER	30	F01200232	NUT M6X1 U5588 6.8ZN
14	F01020445	SCR. M8X1,25X30 U5739 8.8ZN	31	F01040071	SCR. M6X1X80 U5931 8.8ZN
15	G15430331	GEAR LEVER	32	G17131370	LOCK PLATE Q.20 COMPLETE
16	F01410051	WASHER M8 8,4X17X1,6 U6592 ZN	33	F05010633	ENCODER DJ 360 IMP/RPM +CABLE
17	F01020063	SCR. M8X1,25X35 U5737 8.8ZN			

TAV. 090

«SEDD CONTROL» version NOT integrated hydraulic function

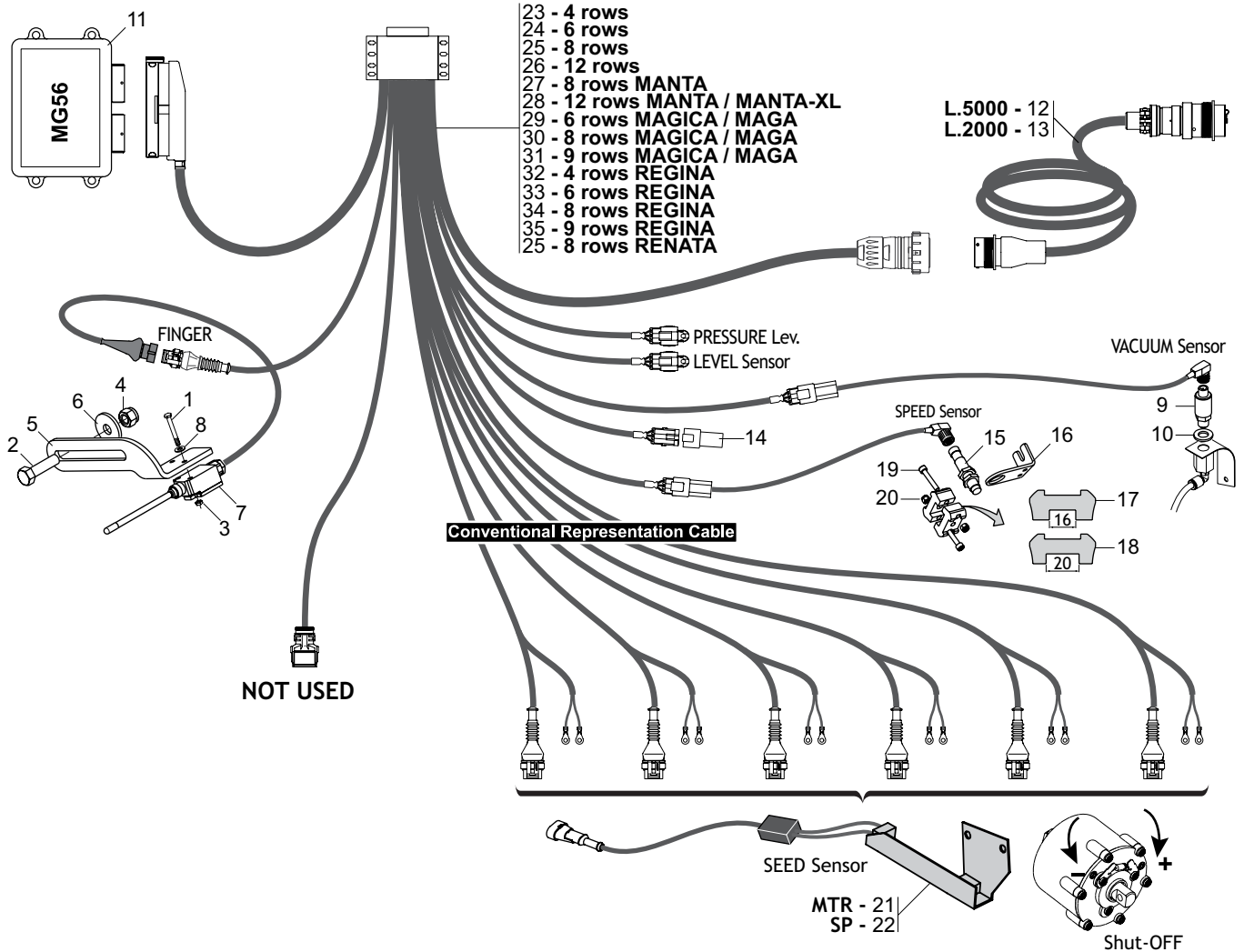

HYDRAULIC FUNCTIONS cable see Spare Parts book of the vacuum Precision Planters.

Pos.	Cod.	Description	Pos.	Cod.	Description
1	F01020024	SCR. M5X0,8X40 U5737 8.8ZN	23	F05200354	CABLE 4R 80 GM
2	F01020521	SCR. M12X1,75X65 U5739 8.8ZN	24	F05200356	CABLE 6R 80 GM
3	F01200220	NUT M5X0,8 U5588 6.8ZN	25	F05200358	CABLE 8R 80 GM
4	F01230059	LOCK-NUT M12X1,75 D982 8ZN	26	F05200362	CABLE 12R 50 GM
5	GA7912420	BLADE SUPPORT FINGER ZN	27	F05200518	CABLE 8R 80 MANTA GM
6	G20970085	WASHER 40X4X13	28	F05200363	CABLE 12R 75 MANTA XL GM
7	G17311430	FINGER WITH PIN	29	F05200516	CABLE 6R 80 MAGICA GM
8	F01420023	WASHER M5 5,3X 15X1,5 U6593	30	F05200517	CABLE 8R 80 MAGICA GM
9	F05011136	DEPRES.SENSOR -200MBAR 0,5-4,5	31	F05200360	CABLE 9R MAGICA GM
10	F05150479	PRESSURE GAUGE REST WASHER	32	F05200560	CABLE REGINA 4R 80 GM
11	F05011503	ECU-ASSY MG 56 GM MECH.PR.	33	F05200561	CABLE REGINA 6R 80 GM
12	F05200320	M-F ISOBUS CABLE 5 METERS	34	F05200562	CABLE REGINA 8R 80 GM
13	F05200285	M-F ISOBUS CABLE 2 METERS	35	F05200563	CABLE REGINA 9R GM
14	GB5940150	CAN TERM 120 OHM			
15	F05010396	SENSOR IND. NBN4-12GM50-EO-V1			
16	G16610240	GALVANIS. UNIVERSAL SENSOR BRA			
17	G16610250	SENSOR READING BLOCK Q.16			
18	G16610440	SENSOR READING BLOCK Q.20			
19	F01040047	SCR. M5X0,8X30 U5931 A2IX			
20	F01230019	NUT M5X0,8 D982 8ZN			
21	F05011459	SENSOR MC MTR 12V WITH AMP			
22	F05011515	SENSOR MC SP 12V WITH AMP			

TAV. 100

«SEDD CONTROL» version WITH integrated hydraulic function

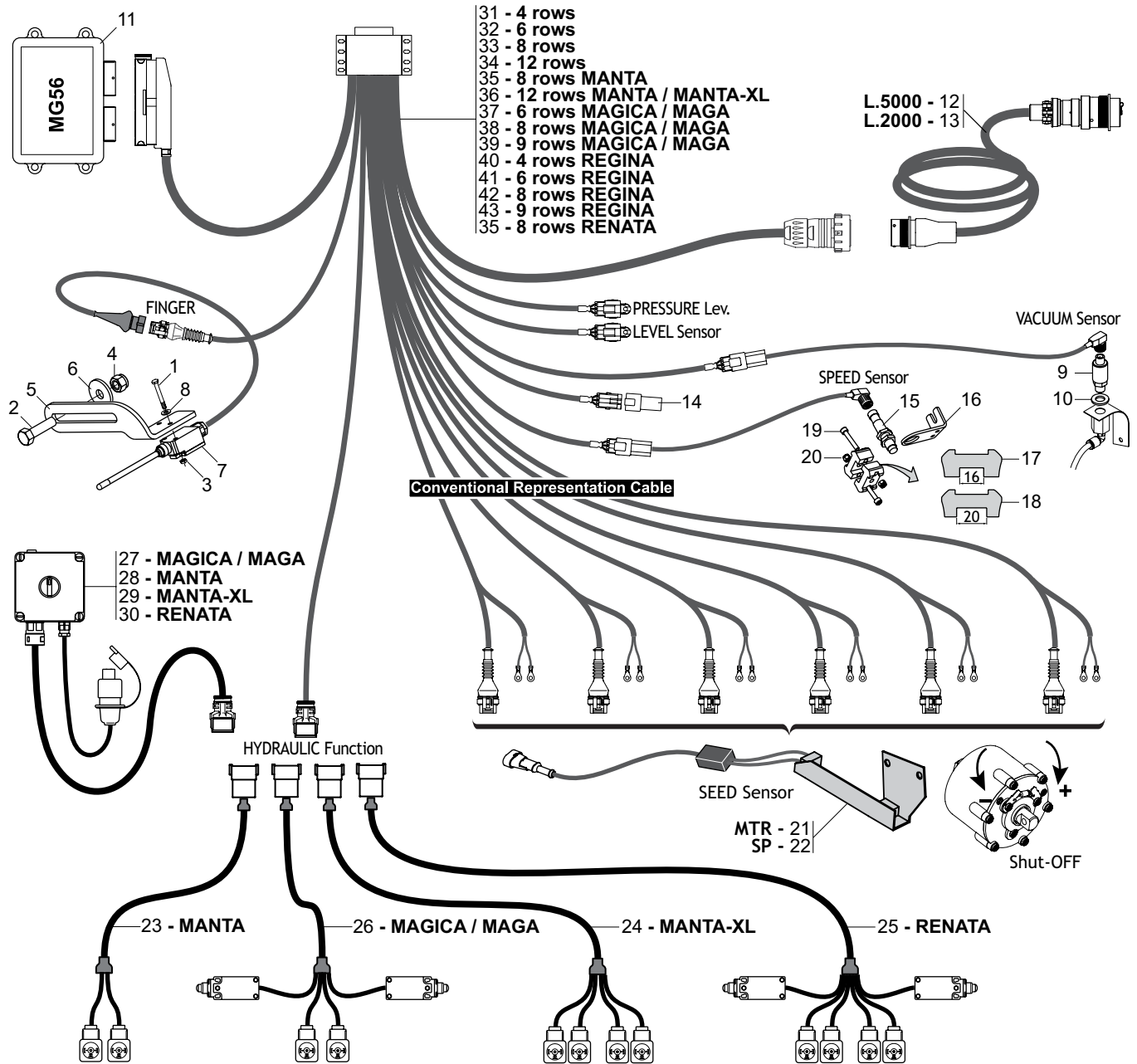

Pos.	Cod.	Description	Pos.	Cod.	Description
1	F01020024	SCR. M5X0,8X40 U5737 8.8ZN	23	F05200404	CABLE 2 COM.EV.MAGICA G.M.
2	F01020521	SCR. M12X1,75X65 U5739 8.8ZN	24	F05200367	CABLE 4 COMMANDS ELETTROVALVE
3	F01200220	NUT M5X0,8 U5588 6.8ZN	25	F05011145	WIRING RENATA-MARISA
4	F01230059	LOCK-NUT M12X1,75 D982 8ZN	26	F05200398	CABLE 2 COM.EV.MAGICA-MAGA G.M
5	GA7912420	BLADE SUPPORT FINGER ZN	27	F05011817	SHUNT BOX HYDR.COMMANDS
6	G20970085	WASHER 40X4X13	28	F05011936	BOX COM.HYDR. MANTA
7	G17311430	FINGER WITH PIN	29	F05011934	BOX COM.HYDR. MANTA XL
8	F01420023	WASHER M5 5,3X 15X1,5 U6593	30	F05011935	BOX COM.HYDR. RENATA-MARISA
9	F05011136	DEPRES. SENSOR -200MBAR 0,5-4,5	31	F05200354	CABLE 4R 80 GM
10	F05150479	PRESSURE GAUGE REST WASHER	32	F05200356	CABLE 6R 80 GM
11	F05011503	ECU-ASSY MG 56 GM MECH.PR.	33	F05200358	CABLE 8R 80 GM
12	F05200320	M-F ISOBUS CABLE 5 METERS	34	F05200362	CABLE 12R 50 GM
13	F05200285	M-F ISOBUS CABLE 2 METERS	35	F05200518	CABLE 8R 80 MANTA GM
14	GB5940150	CAN TERM 120 OHM	36	F05200363	CABLE 12R 75 MANTA XL GM
15	F05010396	SENSOR IND. NBN4-12GM50-EQ-V1	37	F05200516	CABLE 6R 80 MAGICA GM
16	G16610240	GALVANIS. UNIVERSAL SENSOR BRA	38	F05200517	CABLE 8R 80 MAGICA GM
17	G16610250	SENSOR READING BLOCK Q.16	39	F05200360	CABLE 9R MAGICA GM
18	G16610440	SENSOR READING BLOCK Q.20	40	F05200560	CABLE REGINA 4R 80 GM
19	F01040047	SCR. M5X0,8X30 U5931 A2IX	41	F05200561	CABLE REGINA 6R 80 GM
20	F01230019	NUT M5X0,8 D982 8ZN	42	F05200562	CABLE REGINA 8R 80 GM
21	F05011459	SENSOR MC MTR 12V WITH AMP	43	F05200563	CABLE REGINA 9R GM
22	F05011515	SENSOR MC SP 12V WITH AMP			

TAV. 110

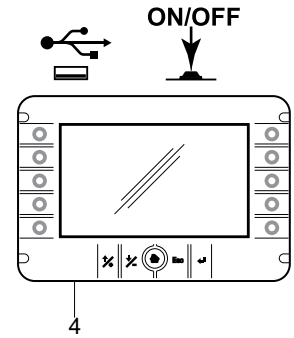
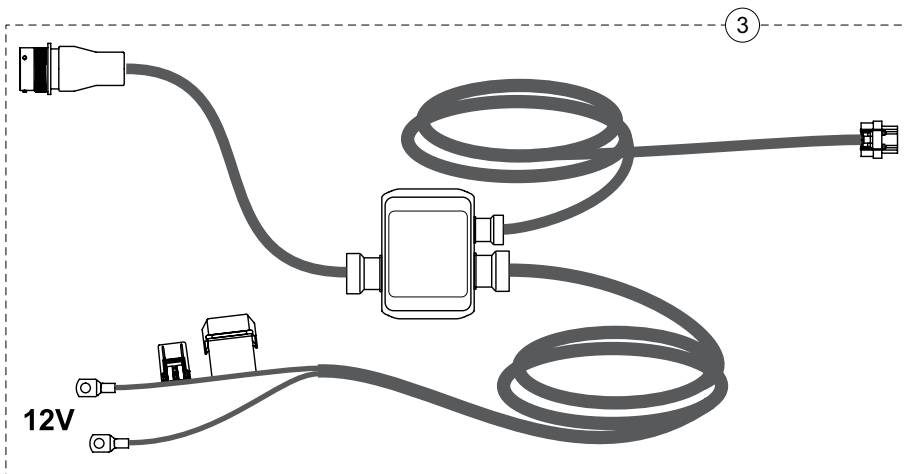
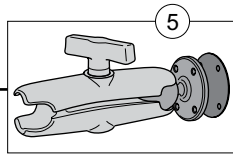
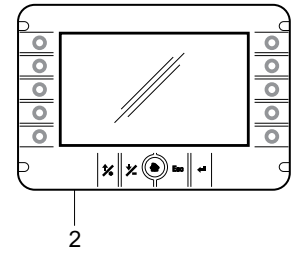
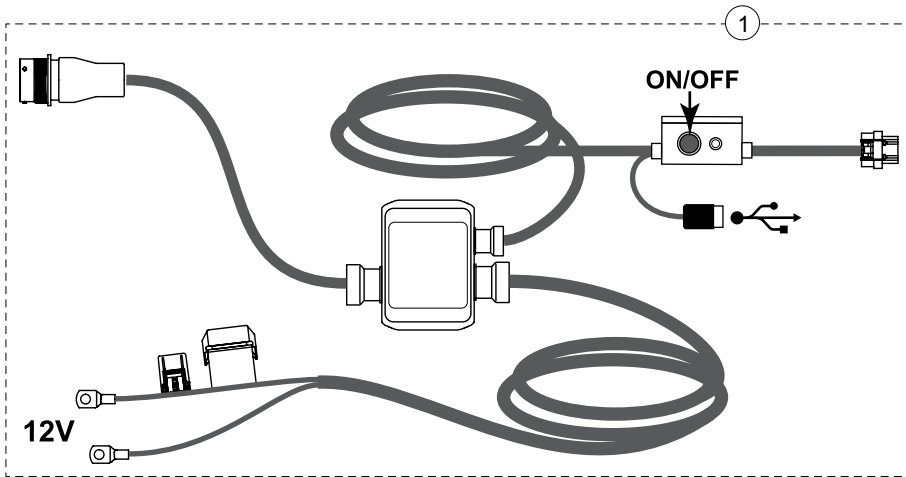

Pos.	Cod.	Description	Pos.	Cod.	Description
1	F05200365	CABLE MONITOR GM 7"			
2	F05011497	MONITOR ASSY TERA 7"			
3	F05200546	CABLE MONITOR GM 7"			
4	F05011637	MONITOR ASSY TERA 7" UT W/USB			
5	F05011600	KIT BRACKET RAM BASE TERA 7			

Notes

USATE SEMPRE RICAMBI ORIGINALI
ALWAYS USE ORIGINAL SPARE PARTS
IMMER DIE ORIGINAL-ERSATZTEILE VERWENDEN
EMPLOYEZ TOUJOURS LES PIECES DE RECHANGE ORIGINALES
UTILIZAR SIEMPRE REPUESTOS ORIGINALES
ВСЕГДА ИСПОЛЬЗУЙТЕ ОРИГИНАЛЬНЫЕ ЗАПЧАСТИ
UTILIZAR SEMPRE PEÇAS DE REPOSIÇÃO ORIGINAIS

GASPARDO

Serviço de Assistência Técnica - After Sales Service: +39 0434 695557

Serviço de peças de reposição - Spare Parts Service: +39 0434 695496

www.maschionet.com

DEALER:



MASCHIO GASPARDO SpA
Registered Office and Production Plant
Via Marcello, 73 - 35011
Campodarsego (Padova) - Italy
Tel. +39 049 9289810
Fax +39 049 9289900
info@maschio.com
www.maschionet.com

MASCHIO GASPARDO SpA
Production Plant
Via Mussons, 7 - 33075
Morsano al Tagliamento (PN) - Italy
Tel. +39 0434 695410
Fax +39 0434 695425
info@gaspardo.it

MASCHIO DEUTSCHLAND GMBH
Äußere Nürnberger Straße 5
D-91177 Thalmässing - Deutschland
Tel. +49 (0) 9173 79000
Fax +49 (0) 9173 790079
dialog@maschio.de
www.maschionet.de

MASCHIO FRANCE Sarl
Rue Denis Papin ZA
F - 45240 La Ferté Saint Aubin
France
Tel. +33 (0) 2.38.64.12.12
Fax +33 (0) 2.38.64.66.79
info@maschio.fr

000 МАСКИО-ГАСПАРДО РУССИЯ
Улица Пушкина, 117 Б
404130 Волжский
Волгоградская область
Тел. +7 8443 203100
факс. +7 8443 203101
info@maschio.ru

MASCHIO-GASPARDO ROMANIA S.r.l.
Strada Înfrăţirii, 155 - F.N.
315100 Chisineu-Cris (Arad) - România
Tel. +40 257 307030
Fax +40 257 307040
info@maschio.ro

MASCHIO GASPARDO
NORTH AMERICA Inc
112 3rd Avenue East
Dewitt, IA 52742 - USA
Ph. +1 563 659 6400
Fax +1 563 659 6405
info@maschio.us

MASCHIO IBERICA S.L.
MASCHIO-GASPARDO POLAND
MASCHIO-GASPARDO UKRAINA
GASPARDO-MASCHIO TURCHIA
MASCHIO-GASPARDO CINA
MASCHIO-GASPARDO INDIA
MASCHIO-GASPARDO KOREA