

# COPERCHI E ACCESSORI

## TANK LIDS AND ACCESSORIES

### TAPAS Y ACCESORIOS

Coperchi di svariati tipi, filettati o a baionetta, fino al tipo ribaltabile a 180°, trovano applicazione, insieme ai filtri a cestello, nelle cisterne delle più svariate misure e configurazioni.

I coperchi costruiti in Polipropilene assicurano una ottima resistenza ai raggi U.V. ed una durata pressochè illimitata nel tempo.

Various types of lids, hinged up to 180°, threaded or bayonet lock, can be used, along with the filter baskets, with the largest range of different sizes and configuration of tanks.

The lids are made of U.V. resistant Polypropylene to offer an almost unlimited life.

Tapas de diferentes tipos, roscadas, de bayoneta o incluso rebatible a 180°, pueden aplicarse, junto a los filtros de fondo, en los tanques de las más variadas medidas y configuraciones.

Las tapas son realizadas en Polipropileno resistente a los rayos U.V. para asegurar una duración prácticamente ilimitada en el tiempo.

#### Legenda dei simboli - Symbols - Leyenda simbolos



flat

Fissaggio superiore  
For flat surfaces  
Para superficies planas



side

Fissaggio laterale  
Side connection  
Fijación lateral



twin gasket

Fissaggio superiore, con doppia guarnizione  
Twin gasket ring for flat surfaces  
Para superficies planas con doble junta

## COPERCHI RIBALTABILI HINGED TANK LIDS TAPAS REBATIBLES

### Coperchio ribaltabile 180° per serbatoi

- Coperchio ribaltabile 180° per atomizzatori e gruppi da diserbo completo di anello per fissaggio sul serbatoio.
- Versione con sfiato a labirinto.
  - Versione con valvola di sfiato con galleggiante per lavoro su terreni in pendio.
  - Versione chiusa.
  - Disponibili con e senza bloccaggio.
  - Disponibili sia con fissaggio laterale che superiore.
  - Guarnizione di tenuta sul coperchio di serie.
  - **Guarnizione anello da ordinare separatamente.**
  - Bloccaggio a baionetta su sei punti per una perfetta chiusura.
  - Ribaltamento a 180° per evitare sforzi sul coperchio e sul serbatoio.
  - Possibilità di montare la serie di filtri a cestelli in plastica o in acciaio di ns. produzione.

### Tank overturning lid 180°

- Overturning lid 180° with fixing ring to the tank.
- Labyrinth breather version.
  - Air valve with float version to work on sloped ground.
  - Closed version.
  - Available with and without blocking.
  - Available with lateral fixing and for flat surfaces.
  - Seal on the lid as standard.
  - **Ring gasket which must be ordered separately.**
  - Bayonet blocking system on six points for perfect lockup.
  - 180° overturn to prevent stress on lid and tank.
  - Possibility to mount the basket filter series made of plastic or steel of our production.

### Tapa rebatible 180° para tanque

- Tapa rebatible 180° con anillo de fijación al tanque.
- Versión con ventilación en forma de laberinto.
  - Versión con válvula de aireación con flotador para trabajos en terrenos con pendientes.
  - Versión cerrada.
  - Disponibles con y sin bloqueo.
  - Disponibles ya sea con fijación lateral o para superficies planas.
  - Junta de estanqueidad de serie en la tapa.
  - **Junta superior que debe ordenarse por separado.**
  - Bloqueo tipo bayoneta en seis puntos para un cierre perfecto.
  - Apertura 180° para evitar esfuerzos sobre la tapa y sobre el depósito.
  - Posibilidad de montar la serie de filtros de cesta de plástico o de acero de nuestra producción.

Versione senza bloccaggio di chiusura  
Version without lockup blocking  
Versión sin bloqueo de cierre



Versione con bloccaggio di chiusura  
Version with lockup blocking  
Versión con bloqueo de cierre



Fissaggio superiore  
For flat surfaces  
Para superficies planas

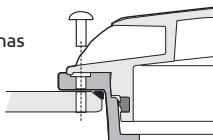

Fissaggio laterale  
Side fixing  
Fijación lateral

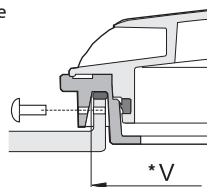

Guarnizione  
Gasket  
Junta

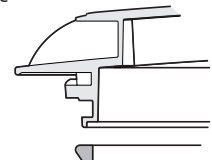

Sfiato con galleggiante e labirinto

Breather with float and labyrinth

Ventilación con flotador y laberinto

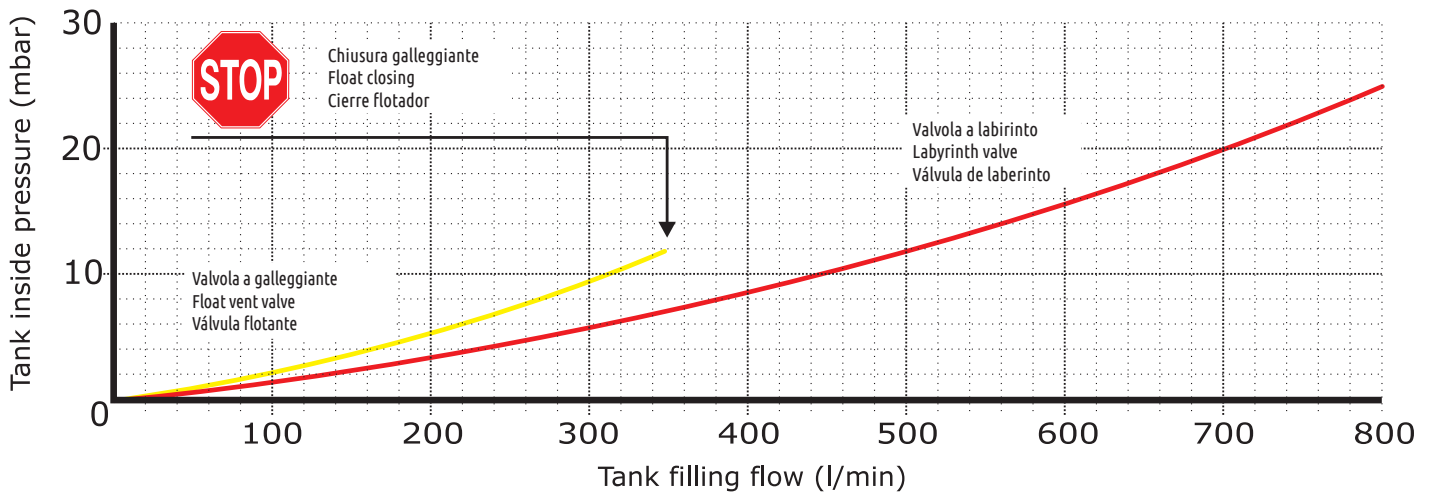

Sfiato con galleggiante

Float vent valve

Válvula con flotante

Con bloccaggio  
Lockable  
Con bloqueo

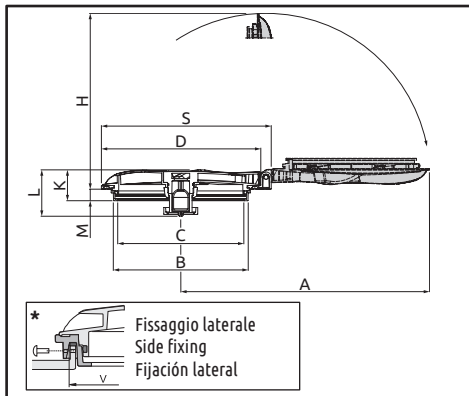

COD. CODE CÓD.	Lockable	D (mm)	B (mm)	C (mm)	K (mm)	M (mm)	H (mm)	S (mm)	A (mm)	V* (mm)	L (mm)	Box	COD. EPDM EPDM CODE CÓD. EPDM	COD. CODE CÓD.
356040	---	---	---	---	---	---	---	---	---	---	---	---	---	---
356041	●	Ø367	Ø320	Ø290	68	26.5	404	390	572	---	104	15	350 440.020	300120 300330
356045	←									336				
356046	●	---	---	---	---	---	---	---	---	---	---	---	---	---
356060	---	---	---	---	---	---	---	---	---	---	---	---	---	---
356061	●	Ø462	Ø415	Ø382	75	26.5	501	486	713	---	105	12	350 460.020	300126 300130 300134
356065	←									428				
356066	●	---	---	---	---	---	---	---	---	---	---	---	---	---

Accessori da ordinare separatamente  
Accessories to order separately  
Accesorios a pedir por separado

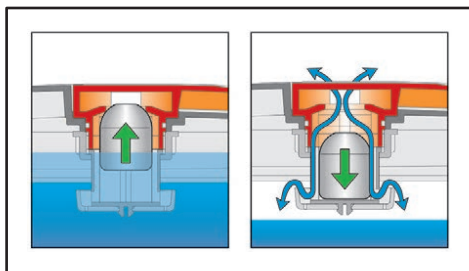

1  
La guarnizione coperchio è già compresa nel codice  
The cover gasket is already included in the code  
La junta de la tapa ya está incluida en el código

Guarniz. di ricambio  
Spare gasket  
Junta de recambio

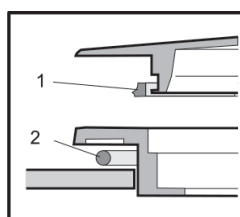

Tipo Type	COD. CODE CÓD.	per for para	Materiale Material
1	3562040.090	Ø 367	NBR
	3562060.090	Ø 462	
2	350440.020	Ø 367	EPDM
	350460.020	Ø 462	

# COPERCHI RIBALTABILI HINGED TANK LIDS TAPAS REBATIBLES

## Sfiato con labirinto

## Labyrinth valve

## Válvula con laberinto

Con bloccaggio  
Lockable  
Con bloqueo

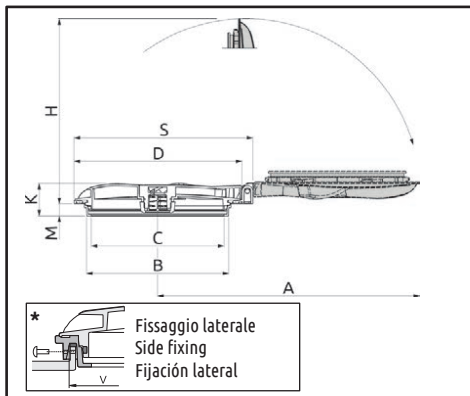

COD. CODE CÓD.	🔒	D (mm)	B (mm)	C (mm)	K (mm)	M (mm)	H (mm)	S (mm)	A (mm)	V* (mm)	📦	🔗 COD. EPDM EPDM CODE CÓD. EPDM	🧺 COD. CODE CÓD.
356240	---												
356241	↓	●	Ø367	Ø320	Ø290	68		404	390	572	15	350440.020	300120 300330
356245	---	●											
356246	←	●									336		
356260	---	●					26.5						
356261	↓	●	Ø462	Ø415	Ø382	75		501	486	713	12	350460.020	300126 300130 300134
356265	---	●											
356266	←	●									428		

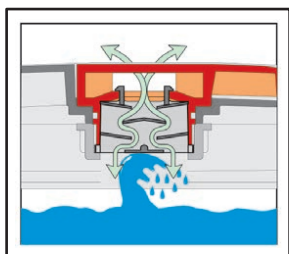

1  
La guarnizione coperchio è già compresa nel codice  
The cover gasket is already included in the code  
La junta de la tapa ya está incluida en el código

Accessori da ordinare separatamente  
Accessories to order separately  
Accesorios a pedir por separado

## Coperchio chiuso

## Closed lid

## Tapa cerrada

Con bloccaggio  
Lockable  
Con bloqueo

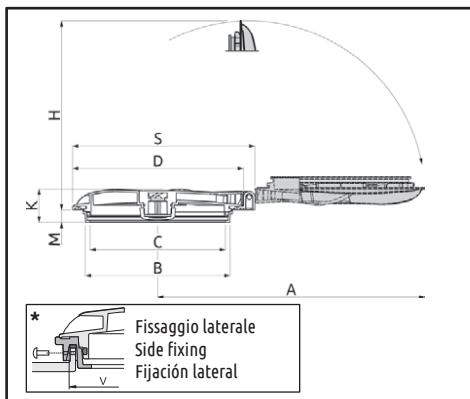

COD. CODE CÓD.	🔒	D (mm)	B (mm)	C (mm)	K (mm)	M (mm)	H (mm)	S (mm)	A (mm)	V* (mm)	📦	🔗 COD. EPDM EPDM CODE CÓD. EPDM	🧺 COD. CODE CÓD.
356140	---												
356141	↓	●	Ø367	Ø320	Ø290	68		404	390	572	15	350440.020	300120 300330
356145	---	●											
356146	←	●									336		
356160	---	●					26.5						
356161	↓	●	Ø462	Ø415	Ø382	75		501	486	713	12	350460.020	300126 300130 300134
356165	---	●											
356166	←	●									428		

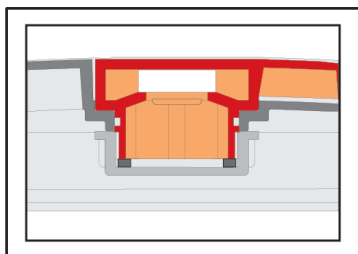

1  
La guarnizione coperchio è già compresa nel codice  
The cover gasket is already included in the code  
La junta de la tapa ya está incluida en el código

Accessori da ordinare separatamente  
Accessories to order separately  
Accesorios a pedir por separado

Guarniz. di ricambio  
Spare gasket  
Junta de recambio

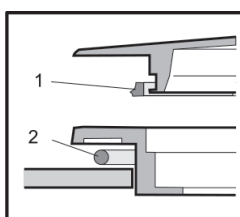

Tipo Type Tipo	COD. CODE CÓD.	per for para	Materiale Material Material
1	3562040.090	Ø 367	NBR
	3562060.090	Ø 462	
2	350440.020	Ø 367	EPDM
	350460.020	Ø 462	

# SMOOTH LINE 2

COPERCHIO CHIUSO  
CLOSED LID  
TAPA CERRADA

C113

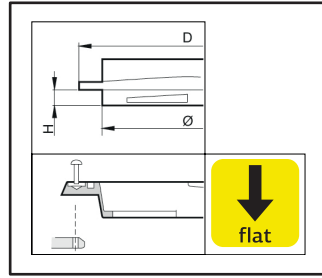

Diametro Diameter D mm	Coperchio Lid Tapa	Anello Ring Aro	Ø	H	Guarnizione Gasket Junta	Filtro Filter Filtro
			mm inches	mm		
140 (4")	3522100	350401	110 4.3"	7	352000.020	300304

Accessori da ordinare separatamente  
Accessories to order separately  
Accesorios a pedir por separado

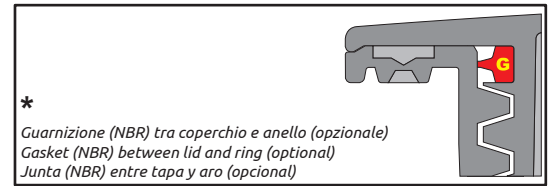
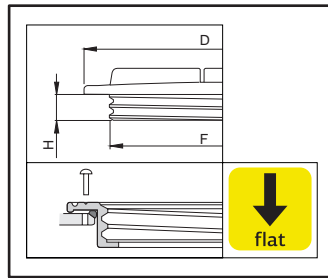

Diametro Diameter D mm	Kit Coperchio + Anello Kit Lid + Ring Kit Tapa + Aro		Coperchio Lid Tapa		Anello Ring Aro		F		H	Guarnizione* Gasket* Junta*	Filtro Filter Filtro
							mm	inches			
250 (8")	3510120	24	3522120	30	3502420	30	210	8.2"	31	3522120.020	300110 300116 300315
355 (12")	3510140	25	3522140	30	3502440	30	313	12.3"	31	3522140.020	300120 300330
455 (16")	3510160	18	3522160	25	3502460	23	410	16.1"	25	3522160.020	300126 300130 300134
620 (22")	3510180	15	3522180	20	350480	18	567	22.3"	30	---	---

Accessori da ordinare separatamente  
Accessories to order separately  
Accesorios a pedir por separado

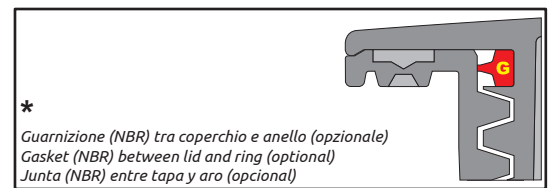
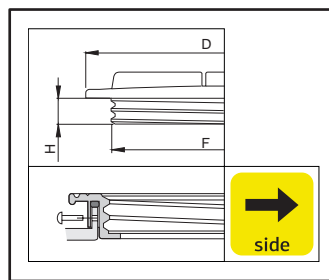

Diametro Diameter D mm	Kit Coperchio + Anello Kit Lid + Ring Kit Tapa + Aro		Coperchio Lid Tapa		Anello Ring Aro		F		H	Guarnizione* Gasket* Junta*	Filtro Filter Filtro
							mm	inches			
250 (8")	3516120	24	3522120	30	3502520	30	210	8,2"	31	3522120.020	300110 300116 300315
355 (12")	3516140	25	3522140	30	3502540	30	313	12,3"	31	3522140.020	300120 300330
455 (16")	3516160	18	3522160	25	3502560	23	410	16,1"	25	3522160.020	300126 300130 300134

Accessori da ordinare separatamente  
Accessories to order separately  
Accesorios a pedir por separado

# SMOOTH LINE 2

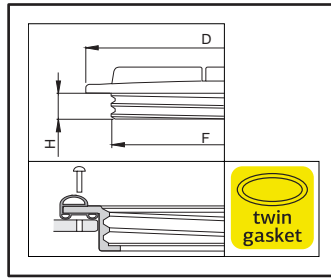

Pagina F-12  
Page F-12  
Página F-12

Diametro Diameter D mm	Kit Coperchio + Anello Kit Lid + Ring Kit Tapa + Aro		Coperchio Lid Tapa		Anello Ring Aro		F		H	Filtro Filter Filtro
							mm	inches	mm	
250 (8")	3514120	20	3522120	30	350620	25	210	8,2"	31	300110 300116 300315
355 (12")	3514140	20	3522140	30	350640	28	313	12,3"	31	300120 300330
455 (16")	3514160	18	3522160	25	350660	23	410	16,1"	25	300126 300130 300134
620 (22")	3514180	14	3522180	20	350680	18	567	22,3"	30	---

Accessori da ordinare separatamente  
Accessories to order separately  
Accesorios a pedir por separado

## MISTRAL

## GHIBLI

Il percorso dei labirinti di sfiato delle valvole **Mistral** e **Ghibli** è stato studiato e ottimizzato per consentire un ampio passaggio di aria e impedire nel contempo la possibile fuoriuscita del liquido dal serbatoio.

The vent circuit of **Mistral** and **Ghibli** has been computer designed to guarantee a large flow yet avoiding liquid out flow.

El recorrido de las válvulas a laberinto **Mistral** y **Ghibli** ha sido estudiado y optimizado para permitir un amplio paso de aire e impedir, mientras tanto, la posible salida de líquido del depósito.

MISTRAL

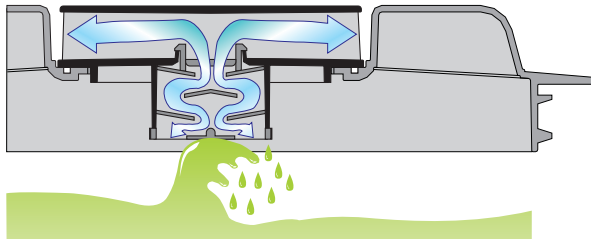

GHIBLI

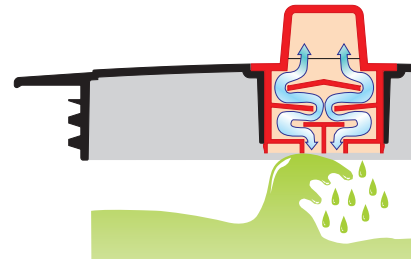

Le nuove valvole sfiato **Mistral** e **Ghibli** sono caratterizzate da una grande capacità di scarico dell'aria per consentire un rapido riempimento del serbatoio. Nel grafico si possono notare le curve (rossa e blu) decisamente più basse e quindi con migliori prestazioni, rispetto alla precedente serie (curva nera).

The new breather valves **Mistral** and **Ghibli** feature a great flow allowing fast tank filling with big pumps. See the flow diaphragm lines (red and blue) definitely more performant than the black line referred to our old series and to the competition's flow.

Las nuevas válvulas de laberinto **Mistral** y **Ghibli** se caracterizan por una gran capacidad de descargue del aire, para permitir un rápido llenado del depósito. En el gráfico pueden apreciarse las curvas (roja y azul) evidentemente más bajas, y por lo tanto con mejores prestaciones, respecto a la serie anterior (curva negra).

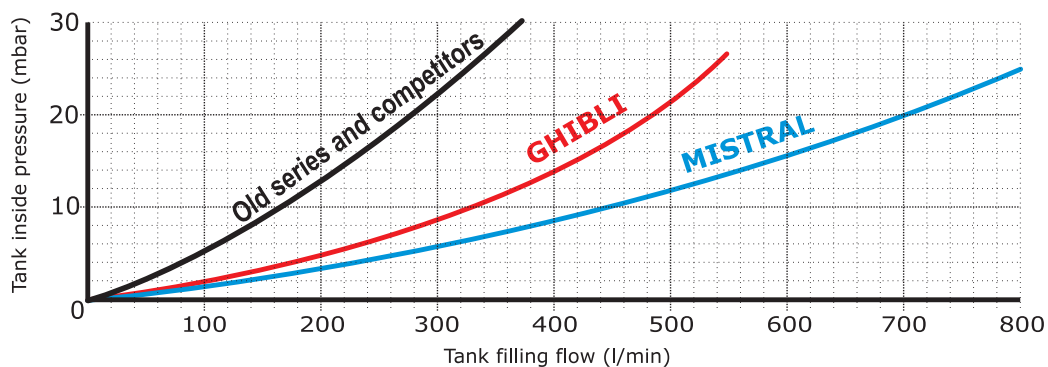

# SMOOTH LINE 2

## MISTRAL

### Coperchio filettato serie "Smooth-line 2" con sfiato a labirinto estraibile "MISTRAL"

Realizzato secondo le attuali norme antinquinamento è munito di un gruppo valvola a doppio sfiato che permette lo svuotamento rapido del serbatoio a coperchio chiuso anche con pompa di grossa portata.

### "Smooth-line 2" threaded lids with removable labyrinth breather "MISTRAL"

Made to current anti-pollution standards, the lid is equipped with a double breather valve to empty the tank quickly with the lid closed, even with a high-delivery pump.

### Tapas roscadas serie "Smooth-line 2" con respiradero de laberinto extraíble "MISTRAL"

Realizada según las actuales normas anticontaminación, está provista de un grupo válvula de doble respiradero que permite el vaciado rápido de la cisterna con la tapa cerrada, incluso con bombas de gran caudal.

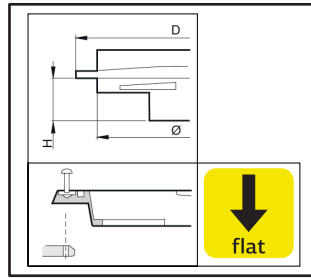

Diametro Diameter D mm	Kit Coperchio + Anello Kit Lid + Ring Kit Tapa + Aro	Coperchio Lid Tapa	Anello Ring Aro	Ø		H	Guarnizione Gasket Junta	Filtro Filter Filtro
				mm	inches			
140 (4")	3510000	3522000	350401	110	4.3"	33	352000.020	300304

Accessori da ordinare separatamente  
Accessories to order separately  
Accesorios a pedir por separado

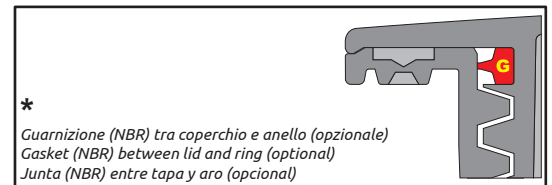
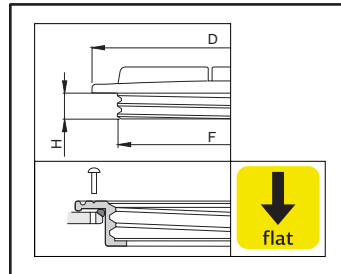

Diametro Diameter D mm	Kit Coperchio + Anello Kit Lid + Ring Kit Tapa + Aro	Coperchio Lid Tapa	Anello Ring Aro	F		H	Guarnizione* Gasket* Junta*	Filtro Filter Filtro			
				mm	inches				mm		
355 (12")	3510040	25	3522040	30	3502440	30	313	12.3"	31	3522140.020	300120 300330
455 (16")	3510060	18	3522060	25	3502460	23	410	16.1"	25	3522160.020	300126 300130 300134
620 (22")	3510080	15	3522080	20	350480	18	567	22.3"	30	---	---

Accessori da ordinare separatamente  
Accessories to order separately  
Accesorios a pedir por separado

# MISTRAL

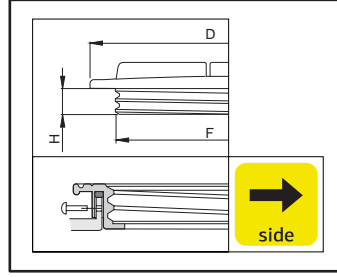

**\***  
 Guarnizione (NBR) tra coperchio e anello (opzionale)  
 Gasket (NBR) between lid and ring (optional)  
 Junta (NBR) entre tapa y aro (opcional)

Diametro Diameter D mm	Kit Coperchio + Anello Kit Lid + Ring Kit Tapa + Aro	Coperchio Lid Tapa	Anello Ring Aro	F		H	Guarnizione* Gasket* Junta*	Filtro Filter Filtro
				mm	inches			
355 (12")	3516040	3522040	3502540	313	12.3"	31	3522140.020	300120 300330
455 (16")	3516060	3522060	3502560	410	16.1"	25	3522160.020	300126 300130 300134

Accessori da ordinare separatamente  
 Accessories to order separately  
 Accesorios a pedir por separado

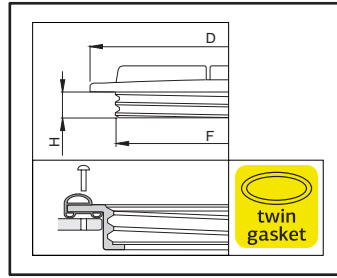

Pagina F-12  
 Page F-12  
 Página F-12

Diametro Diameter D mm	Kit Coperchio + Anello Kit Lid + Ring Kit Tapa + Aro	Coperchio Lid Tapa	Anello Ring Aro	F		H	Filtro Filter Filtro
				mm	inches		
355 (12")	3514040	3522040	350640	313	12.3"	31	300120 300330
455 (16")	3514060	3522060	350660	410	16.1"	25	300126 300130 300134
620 (22")	3514080	3522080	350680	567	22.3"	30	—

Accessori da ordinare separatamente  
 Accessories to order separately  
 Accesorios a pedir por separado



**COD. / CODE / CÓD.**  
**352 000.020**

Guarnizione (EPDM) tra valvola e coperchio (opzionale)  
 Gasket (EPDM) between valve and lid (optional)  
 Junta (EPDM) entre válvula y tapa (opcional)



# SMOOTH LINE 2

COPERCHI  
LIDS  
TAPAS

C113

## GHIBLI

### Coperchio filettato serie "Smooth-line 2" con sfiato fisso a labirinto "GHIBLI"

Realizzato secondo le attuali norme antinquinamento è munito di un gruppo valvola a doppio sfiato che permette lo svuotamento rapido del serbatoio a coperchio chiuso anche con pompa di grande portata.

### "Smooth-line 2" threaded lids with fixed labyrinth breather "GHIBLI"

Made to current anti-pollution standards, the lid is equipped with a double breather valve to empty the tank quickly with the lid closed, even with a high-delivery pump.

### Tapas roscadas serie "Smooth-line 2" con respiradero fijo de laberinto "GHIBLI"

Realizada según las actuales normas anticontaminación, está provista de un grupo válvula de doble respiradero que permite el vaciado rápido de la cisterna con la tapa cerrada, incluso con bombas de gran caudal.

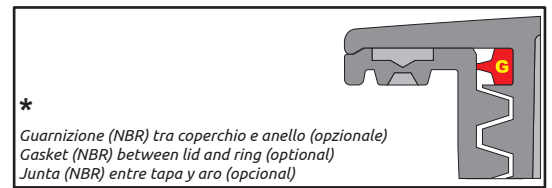
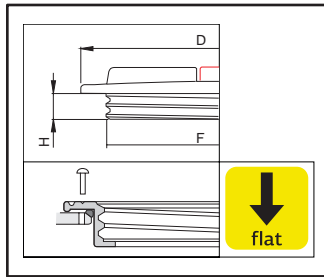

\*  
Guarnizione (NBR) tra coperchio e anello (opzionale)  
Gasket (NBR) between lid and ring (optional)  
Junta (NBR) entre tapa y aro (opcional)

Diametro Diameter Diametro D mm	Kit Coperchio + Anello Kit Lid + Ring Kit Tapa + Aro	Coperchio Lid Tapa	Anello Ring Aro	F		H	Guarnizione* Gasket* Junta*	Filtro Filter Filtro			
				mm	inches						
250 (8")	3510221	23	3522221	28	3502420	30	210	8,2"	31	3522120.020	300110 300116 300315
355 (12")	3510241	25	3522241	30	3502440	30	313	12.3"	31	3522140.020	300120 300330
455 (16")	3510261	18	3522261	25	3502460	23	410	16.1"	25	3522160.020	300126 300130 300134

Accessori da ordinare separatamente  
Accessories to order separately  
Accesorios a pedir por separado



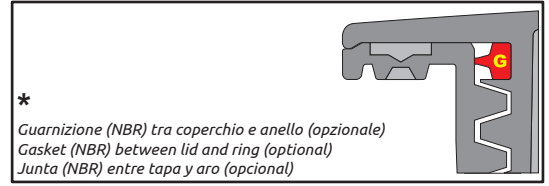
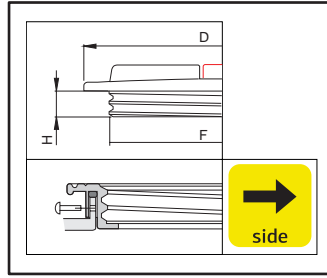

Diametro Diameter D mm	Kit Coperchio + Anello Kit Lid + Ring Kit Tapa + Aro		Coperchio Lid Tapa		Anello Ring Aro		F		H	Guarnizione* Gasket* Junta*	Filtro Filter Filtro
							mm	inches			
250 (8")	3516221	23	3522221	28	3502520	30	210	8.2"	31	3522120.020	300110 300116 300315
355 (12")	3516241	25	3522241	30	3502540	30	313	12.3"	31	3522140.020	300120 300330
455 (16")	3516261	18	3522261	25	3502560	23	410	16.1"	25	3522160.020	300126 300130 300134

Accessori da ordinare separatamente  
Accessories to order separately  
Accesorios a pedir por separado

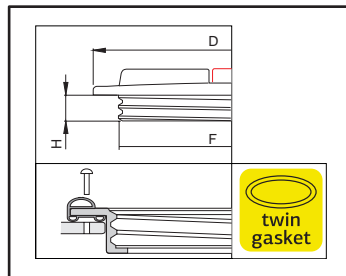

Pagina F-12  
Page F-12  
Página F-12

Diametro Diameter D mm	Kit Coperchio + Anello Kit Lid + Ring Kit Tapa + Aro		Coperchio Lid Tapa		Anello Ring Aro		F		H	Filtro Filter Filtro
							mm	inches		
250 (8")	3514221	20	3522221	28	350620	25	210	8.2"	31	300110 300116 300315
355 (12")	3514241	22	3522241	30	350640	28	313	12.3"	31	300120 300330
455 (16")	3514261	18	3522261	25	350660	23	410	16.1"	25	300126 300130 300134

Accessori da ordinare separatamente  
Accessories to order separately  
Accesorios a pedir por separado

Coperchio chiuso



Closed lid

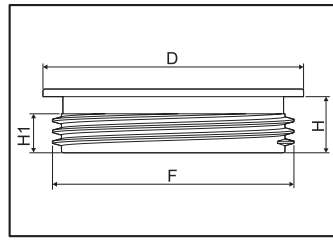

Tapa cerrada

COD. CODE CÓD.	D (mm)	H (mm)	H1 (mm)	F	
				(mm)	(inches)
<b>C00001</b>	137	30	21	127	5"

ANELLI PER COPERCHI  
LID RINGS  
AROS PARA TAPAS

Anello filettato con fissaggio superiore



Threaded ring for flat surfaces

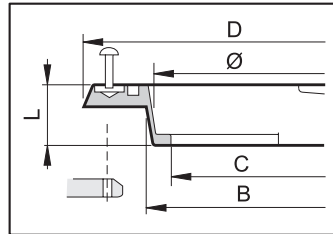

Aro roscado para superficies planas

COD. CODE CÓD.	D (mm)	B (mm)	C (mm)	L (mm)	Ø		COD. CODE CÓD.
					(mm)	(inches)	
<b>350401</b>	159	125	112	17	120	4,7"	<b>300304</b>

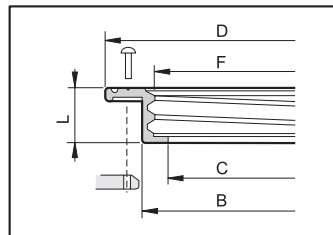

COD. CODE CÓD.	D (mm)	B (mm)	C (mm)	L (mm)	F		COD. CODE CÓD.	
					(mm)	(inches)		
<b>3502420</b>	255	219	192	38	210	8,2"	300110 300116 300315 300120 300330	
<b>3502440</b>	360	320	290		313	12,3"		
<b>3502460</b>	462	415	382	35	410	16,1"		
<b>350480</b>	620	575	540	41	567	22,3"	18	---

Anello filettato fissaggio laterale



Threaded ring with side connection

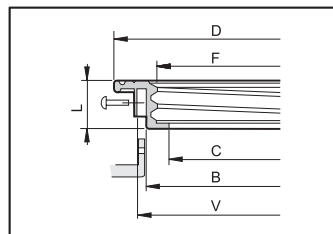

Aro roscado fijación lateral

COD. CODE CÓD.	D (mm)	B (mm)	C (mm)	V (mm)	L (mm)	F		COD. CODE CÓD.
						(mm)	(inches)	
<b>3502520</b>	255	219	192	230	38	210	8,2"	300110 300116 300315 300120 300330
<b>3502540</b>	360	320	290	335		313	12,3"	
<b>3502560</b>	462	415	382	430	35	410	16,1"	

Guarnizioni di tenuta tra serbatoio e anello

Sealing gaskets between tank and ring

Juntas de sellado entre tanque y aro

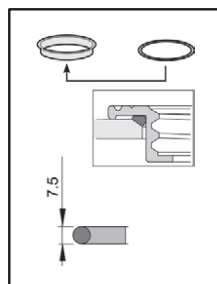

COD. CODE CÓD.	Per anelli For ring Para aros
<b>350401.020</b>	350401
<b>350420.020</b>	3502420 3502520
<b>350440.020</b>	3502440 3502540
<b>350460.020</b>	3502460 3502560
<b>350480.020</b>	350480

# COPERCHI LIDS TAPAS

Anello filettato con doppia guarnizione  
per fissaggio superiore



Threaded ring for flat surfaces with  
double gasket

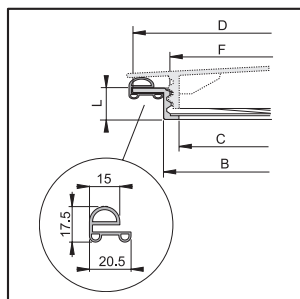

Aro roscado para superficies planas con  
doble junta

COD. CODE CÓD.	D (mm)	B (mm)	C (mm)	L (mm)	F		COD. CODE CÓD.
					(mm)	(inches)	
350620	255	215	192	38	210	8,2"	300110 300116 300315
					313	12,3"	300120 300330
350660	462	415	382	35	410	16,1"	300126 300130 300134
350680	620	575	540	41	567	22,3"	---

Ricambi  
Spare parts  
Repuestos

D (mm)	Guarnizione Gasket Junta
255 (8")	350620.020
355 (12")	350640.020
460 (16")	350660.020
620 (22")	350680.020

# COPERCHI IN GOMMA RUBBER LIDS TAPAS DE GOMA

Coperchio in gomma con valvola di  
aspirazione



Rubber lids with suction valve

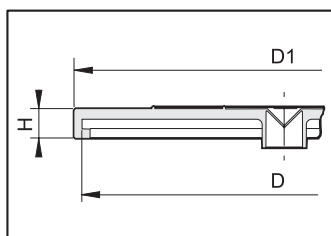

Tapas de goma con válvula de aspiración

COD. CODE CÓD.	D (mm)	H (mm)	D1 (mm)	COD. CODE CÓD.
352420	240	15	265	300112 300118 300212 300320
			370	300120 300330
			450	300128 300132 300136
352440	360	22	450	---



Coperchio con valvola di sfiato a labirinto completo di guarnizione



Lid with labyrinth breather valve complete with gasket

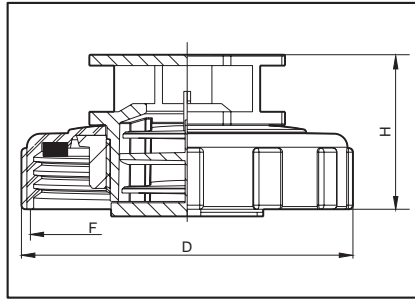

COD. CODE CÓD.	D (mm)	H (mm)	F (mm) (inches)	
<b>354231</b>	122	57	113	4.5"

Tapa con válvula de ventilación laberíntica completa con junta

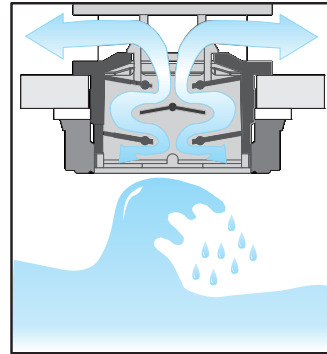

Guarniz. di ricambio (NBR)  
Spare gasket (NBR)  
Junta de recambio (NBR)

**COD.  
CODE  
CÓD.**  
**354030.020**

Coperchio con valvola di sfiato a membrana completo di guarnizione



Lid with diaphragm breather valve complete with gasket

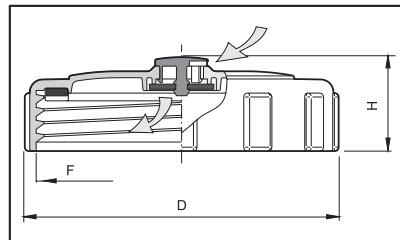

COD. CODE CÓD.	D (mm)	H (mm)	F (mm) (inches)	
<b>354230</b>	122	36.5	113	4,5"

Guarniz. di ricambio (NBR)  
Spare gasket (NBR)  
Junta de recambio (NBR)

**COD.  
CODE  
CÓD.**  
**354030.020**

Tapa con membrana de respiradero completa con junta

Coperchio chiuso completo di guarnizione



Closed lid complete with gasket

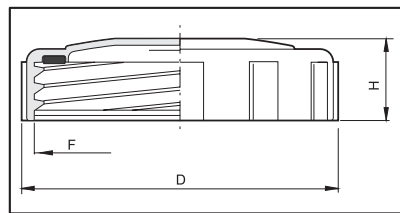

COD. CODE CÓD.	D (mm)	H (mm)	F (mm) (inches)	
<b>354130</b>	122	32	113	4.5"

Guarniz. di ricambio (NBR)  
Spare gasket (NBR)  
Junta de recambio (NBR)

**COD.  
CODE  
CÓD.**  
**354030.020**

Tapa cerrada completa con junta

Coperchio chiuso trasparente completo di guarnizione



Transparent closed lid complete with gasket

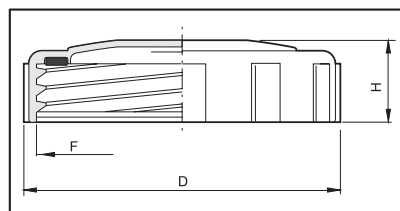

COD. CODE CÓD.	D (mm)	H (mm)	F (mm) (inches)	
<b>354130T</b>	122	32	113	4.5"

Guarniz. di ricambio (NBR)  
Spare gasket (NBR)  
Junta de recambio (NBR)

**COD.  
CODE  
CÓD.**  
**354030.020**

Tapa cerrada transparente completa con junta

# COPERCHI FILETTO FEMMINA PER SERBATOI FEMALE THREADED TANK LIDS TAPAS DE ROSCA HEMBRA PARA CISTERNAS

354

Coperchio con valvola di sfiato a labirinto completo di guarnizione



Lid with labyrinth breather valve complete with gasket

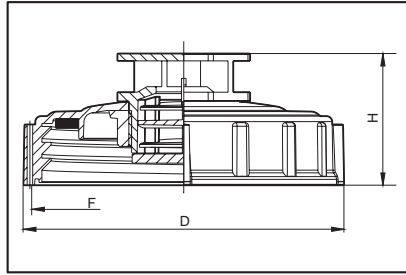

COD. CODE CÓD.	D (mm)	H (mm)	F	
			(mm)	(inches)
<b>3542011</b>	166	71	154	6"

Tapa con válvula de ventilación laberíntica completa con junta

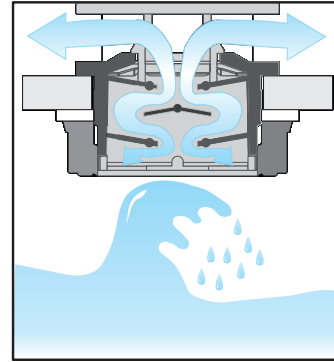

Guarniz. di ricambio (NBR)  
Spare gasket (NBR)  
Junta de recambio (NBR)

COD.  
CODE  
CÓD.

**3542010.020**

Coperchio con sfiato a molla completo di guarnizione



Lid with spring breather and gasket

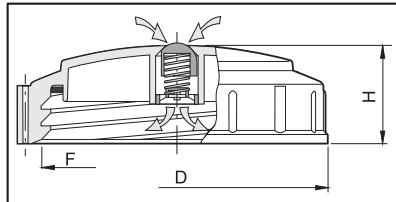

COD. CODE CÓD.	D (mm)	H (mm)	F	
			(mm)	(inches)
<b>3542010</b>	166	47	154	6"

Guarniz. di ricambio (NBR)  
Spare gasket (NBR)  
Junta de recambio (NBR)

COD.  
CODE  
CÓD.

**3542010.020**

Coperchio chiuso completo di guarnizione



Closed lid with gasket

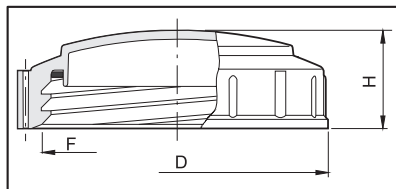

COD. CODE CÓD.	D (mm)	H (mm)	F	
			(mm)	(inches)
<b>3542110</b>	166	47	154	6"

Guarniz. di ricambio (NBR)  
Spare gasket (NBR)  
Junta de recambio (NBR)

COD.  
CODE  
CÓD.

**3542010.020**



Coperchio con foro per valvola di sfiato

Lid with hole for breather valve

Tapa con orificio para válvula de respiradero

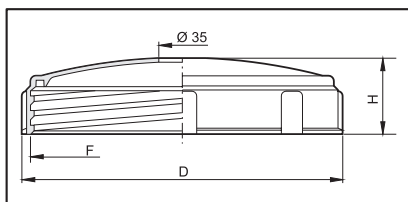

COD. CODE CÓD.	D (mm)	H (mm)	F	
			(mm)	(inches)
<b>354320</b>	240	57	226	9"

Guarniz. opzionale (EPDM)  
Optional gasket (EPDM)  
Junta opcional (EPDM)

COD. CODE CÓD.
<b>G11069</b>

È possibile montare le valvole di sfiato cod. 504201 o 504203 (pag. F-18)  
This lid can also be fitted with breather valves 504201 or 504203 (page F-18)  
Se pueden montar las válvulas de respiradero cód. 504201 ó 504203 (pág. F-18)

Coperchio con valvola di sfiato a membrana

Lid with diaphragm breather valve

Tapa con membrana de respiradero

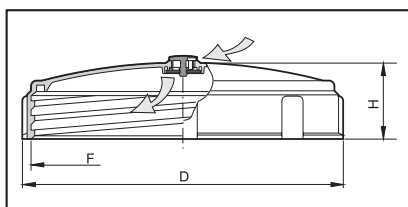

COD. CODE CÓD.	D (mm)	H (mm)	F	
			(mm)	(inches)
<b>354220</b>	240	58.5	226	9"

Guarniz. opzionale (EPDM)  
Optional gasket (EPDM)  
Junta opcional (EPDM)

COD. CODE CÓD.
<b>G11069</b>

Coperchio chiuso

Closed lid

Tapa cerrada

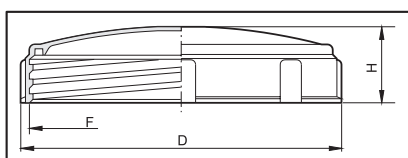

COD. CODE CÓD.	D (mm)	H (mm)	F	
			(mm)	(inches)
<b>354120</b>	240	58.5	226	9"

Guarniz. opzionale (EPDM)  
Optional gasket (EPDM)  
Junta opcional (EPDM)

COD. CODE CÓD.
<b>G11069</b>

Coperchio chiuso "DOT" completo di guarnizione

Closed lid "DOT" with gasket

Tapa cerrada "DOT" con junta

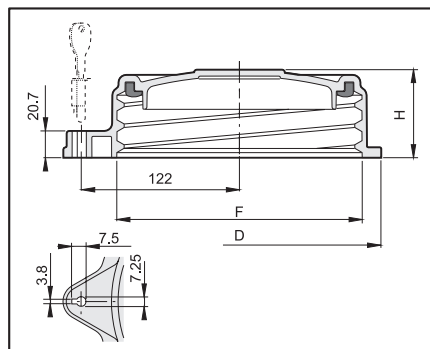

COD. CODE CÓD.	D (mm)	H (mm)	F	
			(mm)	(inches)
<b>354142</b>	219	68	189	7.5"

Guarniz. di ricambio (EPDM)  
Spare gasket (EPDM)  
Junta de recambio (EPDM)

COD. CODE CÓD.
<b>354040.020</b>

# FILTRI IMMISSIONE SERBATOIO

## TANK FILLING FILTER

### FILTROS LLENADO TANQUES

300

Filtro a sacco (rete 18 mesh)

Basket filter (screen 18 mesh)

Filtros en forma de sacco (18 mesh)

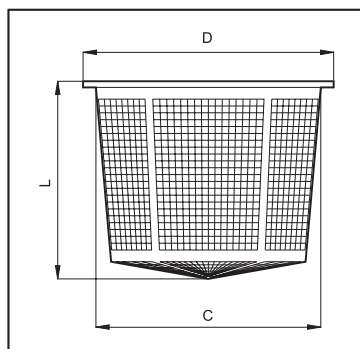

COD. CODE CÓD.	D (mm)	C (mm)	L (mm)	per for para
300140	140	127	203	3542010 3542110
300101	295	285	230	---
300110	203	188	120	3502420 3502520
300116			235	
300112	210	188	120	---
300118			235	
300120	300	288	245	350640 3502440 3502540
				356040 356041 356045 356046
				350660 3502460 3502560
				356060 356065
300126	400	380	185	350660 3502460 3502560
300130			275	
300134			330	
300128	410	380	185	---
300132			275	
300136			330	
300114	194	188	235	Versioni speciali Special versions Versiones especiales
300119	230			
300122	322	288	245	
300124	337			

Filtro a sacco in polipropilene

Polypropylene basket filter

Filtro en forma de sacco de polipropileno

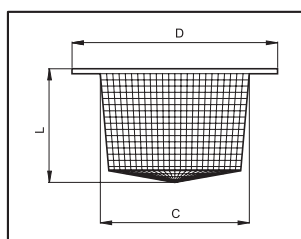

COD. CODE CÓD.	D (mm)	C (mm)	L (mm)
300212	208	162	115

Filtro a tazza

Cup filter

Filtro de taza

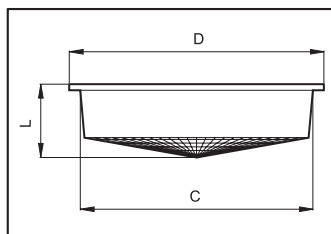

COD. CODE CÓD.	D (mm)	C (mm)	L (mm)	per for para
300309	104	94	35	---
300304	118	108	40	350401
300310	194	187	60	---
300315	204			3502420 3502520 350620
300320	208	194	40	---
300330	302	288	46	350640 3502440 3502540
				356040 356041 356045 356046
				---
				---
300335	322			---



Coperchi e filtri per pompa a spalla

Lids and filters for back-pack sprayer

Tapas y filtros para equipos de mochila

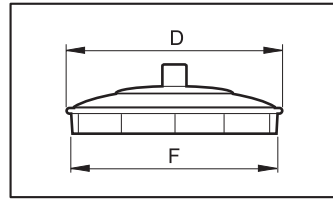

COD. CODE CÓD.	D (mm)	F	
		(mm)	(inches)
<b>300303</b>	90	85	3.3"

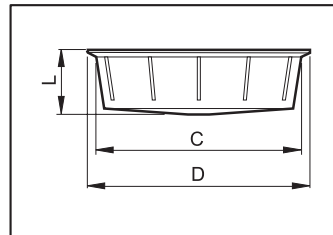

COD. CODE CÓD.	D (mm)	C (mm)	L (mm)
	<b>300302</b>	98	90
<b>300304</b>	118	108	40

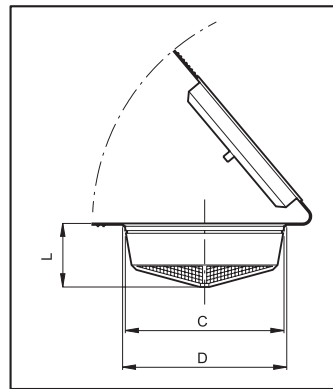

COD. CODE CÓD.	D (mm)	C (mm)	L (mm)
	<b>300307</b>	112	111

Filtro a cestello inox AISI 304

Stainless steel AISI 304 basket filter

Filtro de cesta inox AISI 304

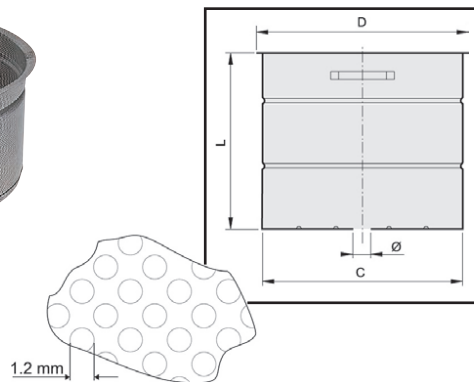

COD. CODE CÓD.	D (mm)	C (mm)	L (mm)	Ø	
				(mm)	(inches)
<b>006960</b>	400	382	333	26	1"

VALVOLE DI SFIATO  
BREATHER VALVES  
VÁLVULAS DE RESPIRADERO

Valvola di sfiato a labirinto

Labyrinth breather valve

Válvula respiradero de laberinto

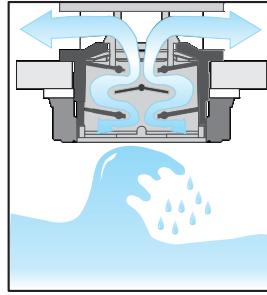
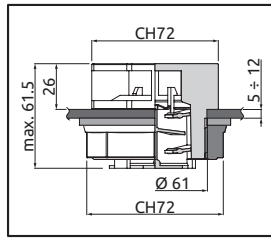

COD.  
CODE  
CÓD.  
**504220**

Valvola di sfiato a sfera galleggiante

Floating ball breather valve

Válvula respiradero de bola flotante

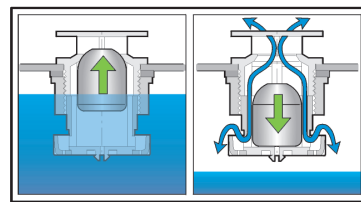
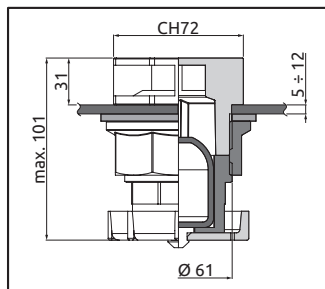

COD.  
CODE  
CÓD.  
**504210**

Valvola in PVC

PVC valve

Válvula de PVC

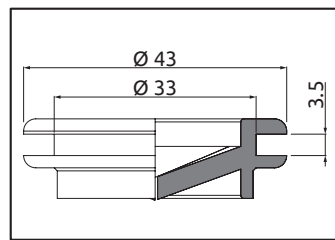
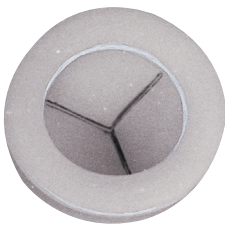

COD.  
CODE  
CÓD.  
**504201**

Valvola di sfiato a labirinto

Labyrinth breather valve

Válvula respiradero de laberinto

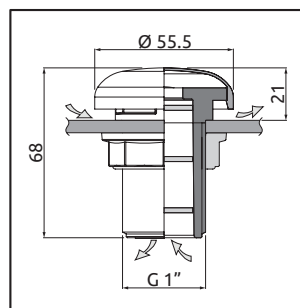

COD.  
CODE  
CÓD.  
**504203**