

# SISTEMI DI CONTROLLO

## CONTROL UNITS

### SISTEMAS DE CONTROL

ARAG, dopo aver realizzato l'attacco a forchetta, continua ad allineare la produzione per renderla completamente modulare e conformata alle esigenze più disparate, nell'ottica di un servizio sempre migliore al cliente.

La gamma dei comandi ARAG è disponibile per i più disparati impieghi in agricoltura e spazia dalle singole valvole ai più sofisticati gruppi di comando.

After having designed the fork coupling, ARAG continues to align the production to make it modular and suitable to meet any requirement with the purpose of providing a constantly improved service to customers.

The series of ARAG controls is suitable to many different agricultural applications and ranges from the single valves to more sophisticated control units.

ARAG, luego de haber hecho la toma de horquilla, sigue alineando la producción para hacerla completamente modular y de acuerdo a las normas más dispares, para ofrecer un servicio cada vez mejor al cliente.

La gama de los mandos ARAG está disponible para los usos más variados en agricultura y su gama va desde las válvulas individuales hasta los más sofisticados grupos de mando.

#### Legenda dei simboli - Symbols - Leyenda simbolos

	Utilizzo consigliato su macchine da diserbo Recommended for use on crop sprayers Se aconseja su uso en máquinas pulverizadoras		Utilizzo consigliato su atomizzatori Recommended for use on orchard sprayers Se aconseja su uso en atomizadores
	Utilizzo consigliato su macchine a basso volume Recommended for use on low-volume machines Se aconseja su uso en máquinas de baja presión		Componente modulare Modular component Componente modular
	Accessorio specifico per computer Specific accessory for computers Accesorio específico para ordenador		Protocollo di comunicazione ARAG conforme alle specifiche CAN BUS. ARAG communication protocol in compliance with CAN BUS specifications. Protocolo de comunicación ARAG conforme a las especificaciones CAN BUS.
	SOLO per valvole MOTORIZZATE For MOTORIZED valves ONLY SOLO para válvulas MOTORIZADAS		SOLO per valvole a SOLENOIDE ONLY for SOLENOID valves SOLO para válvulas de SOLENOIDE
	Raccordo con attacco a forchetta Fitting with fork coupling Racor con conexión de horquilla		Codice O'ring da ordinare separatamente O'ring code to be ordered separately Codigo de O'ring da pedir por separado
	Prodotto codificato secondo norma ISO19732 Product codified in compliance with the Standard ISO19732 Codificación del producto según la norma ISO19732		Valvola con sfera in acciaio AISI 316 Valve with ball in AISI 316 steel Válvula con bola de acero AISI 316
	Valore tipico di assorbimento Typical absorption Valor típico de absorción		Pressione di esercizio Operating pressure Presión de trabajo
	Portata Flow rate Caudal		Tempo di azionamento Operating time Tiempo de accionamiento
	Dimensioni di ingombro Overall dimensions Dimensiones máximas		Caduta di pressione alla massima portata. Pressure drop at maximum flow. Caída de presión en la máxima caudal.
	Nuovi prodotti New items Nuevos productos		Nuovi prodotti New items Nuevos productos



# New 863T electric section valves 3<sup>rd</sup> generation



Both 2 and 3 wire control

Operating  
status LED

New sealed  
connector  
integrated into  
the motor body

Internal protection

New cables  
with molded  
watertight  
connectors

T fork coupling

# COMING SOON

# 863T - 863

## VALVOLE SEZIONE DI BARRA BOOM SECTION VALVES VÁLVULAS SECCIÓN DE BARRA

C113

Le valvole di sezione serie 863T e 863 rappresentano l'evoluzione delle precedenti serie 463 e sono caratterizzate da notevoli migliorie tecniche e progettuali che garantiscono migliori prestazioni e durata nel tempo.

### CARATTERISTICHE GENERALI

- Completamente intercambiabili con le precedenti serie 463.
- Possono essere utilizzate indipendentemente con comando a 2 o 3 fili.
- Connettore incassato nel corpo motore per un montaggio più semplice e sicuro.
- Fusibile interno resettabile (togliendo l'alimentazione per 20 secondi).
- Le valvole di regolazione proporzionale specifiche per computer sono dotate di nuovo sistema di azionamento a lunga durata.

The section valves, series 863T and 863 represent the evolution of the previous series 463 and feature important technical and design improvements that ensure better performance and duration.

### MAIN FEATURES

- Fully interchangeable with the previous 463 series.
- They can be used either with 2-wire or 3-wire control.
- Built-in connector in the motor housing for a simple and safe installation.
- Internal resettable fuse (disconnecting power for 20 seconds).
- The computer-specific proportional control valves are equipped with a new long-lasting drive system.

Las válvulas de sección serie 863T y 863 representan la evolución de las series precedentes 463, se caracterizan por importantes mejoras técnicas y de diseño que garantizan mejores prestaciones así como una mayor duración.

### CARACTERÍSTICAS GENERALES

- Completamente intercambiables con las anteriores series 463.
- Pueden ser utilizadas independientemente con mando de 2 o 3 cables.
- Conector introducido en el cuerpo motor para un montaje más simple y seguro.
- Fusible interior rearmable (parando l'alimentacion para 20 sec.).
- Las válvulas de regulación proporcional, específicas para ordenador, están dotadas de nuevo sistema de accionamiento de larga duración.

## 863T

**T5**  
fork  
coupling

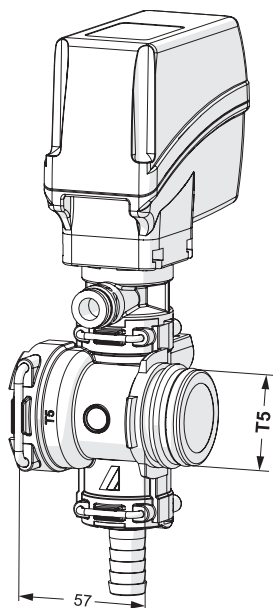
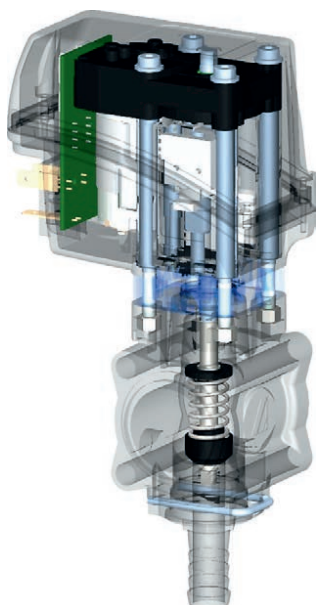

## 863

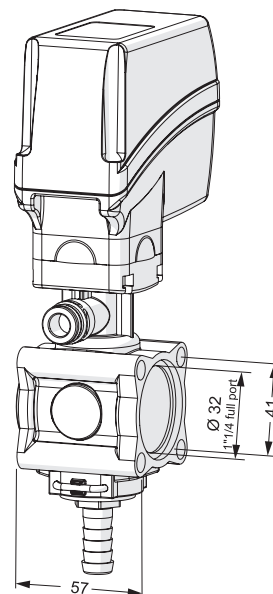

Attacco del connettore incassato nel motore: minore ingombro e connettore più protetto.

Connector integrated in the motor: it saves space and increases the protection of the connector.

Toma del conector integrado en el motor: menor tamaño y conector más protegido.



Il coperchio del gruppo motore è libero e tutti i cablaggi sono contenuti all'interno del gruppo motore: maggiore affidabilità e comodità nell'assistenza.

The motor gear cover is free and all the wiring is included inside the unit: better reliability and easy maintenance.

Tapa del motorreductor libre, todo el cableado está en el interior del grupo motorreductor para mayor fiabilidad y simple asistencia.



863

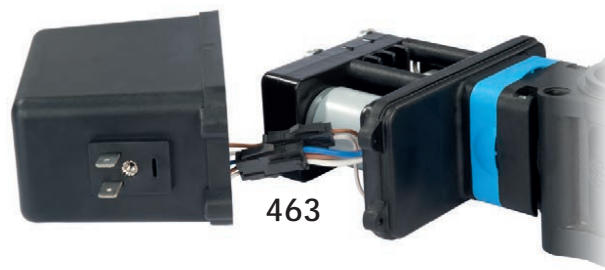

463

# VALVOLE SEZIONE DI BARRA CON ATTACCO A FORCHETTA

## BOOM SECTION VALVES WITH FORK COUPLING

### VÁLVULAS SECCION DE BARRA CON CONEXIÓN DE HORQUILLA

# 863T - 463T

#### Valvola sezione di barra singola ad azionamento elettrico o manuale, con attacco a forchetta

Nate come evoluzione delle precedenti serie 463 e 863, le nuove valvole modulari serie 463T e 863T rappresentano uno straordinario miglioramento sia dal punto di vista tecnico che di modularità.

Grazie infatti alla disponibilità di valvole singole e di gruppi a 3 vie in un solo corpo monoblocco, è possibile comporre gruppi di comando con facilità, senza l'ausilio di attrezzi e secondo le esigenze dell'installatore.

Partendo da una singola valvola o da un gruppo monocorpo a 3 vie è possibile aumentarne il numero aggiungendo altri moduli con attacco a forchetta T5.

Il gruppo può essere finito a discrezione dell'utilizzatore con i raccordi di completamento a forchetta T5 e di uscita T3.

- Disponibili in versione con o senza ritorni calibrati.
- **Sede della tenuta valvola sostituibile ed indipendente dal raccordo di uscita.**
- Sistema di fissaggio integrato brevettato: non necessita di tiranti di assemblaggio né di staffe di supporto.
- Compatibili con tutti i componenti ARAG con attacco a forchetta T5.
- Ampia gamma di raccordi di uscita con attacco a forchetta T3.
- Struttura in Nylon® rinforzato con fibra di vetro.
- Particolari interni in Delrin® e acciaio Inox AISI 303
- Valvole fornite complete di O'ring in Viton® e forchette.
- O'ring e forchette per accessori di completamento T5 e T3 da ordinare separatamente.

#### Single boom section valve with electric or manual activation, with fork coupling

Developed from the previous 463 and 863 series, the new 463T and 863T modular valves represent an extraordinary improvement both technically and in terms of modular features. Thanks to the availability of single valves and 3-way units in a single block body, it is easy to set up control units without using tools and according to installer needs.

Starting from a single valve or a 3-way single block unit it is possible to add other modules with T5 fork coupling.

The unit can be complemented with T5 fork end fittings and T3 outlet fittings as required by user.

- Available with or without metered by-pass.
- **Possibility to replace the valve seal seat which is independent from the outlet connector.**
- Patented integrated fixing system eliminates the need for retaining bolts or support brackets.
- Compatible with all ARAG components featuring T5 fork coupling.
- Wide range of T3 outlet fittings with fork coupling.
- Structure in fiber glass reinforced Nylon.
- Internal parts in Delrin® and AISI 303 stainless steel.
- Valves provided with O-rings in Viton® and forks.
- O-rings and forks for T5 and T3 accessories to be ordered separately.

#### Válvula sección de barra individual de accionamiento eléctrico o manual, con empalme de horquilla

Nacidas como una evolución de las anteriores serie 463 y 863, las nuevas válvulas modulares serie 463T y 863T representan una extraordinaria mejora desde el punto de vista técnico y modular.

Gracias a la disponibilidad de válvulas individuales y grupos de 3 vías en un solo cuerpo monobloque, es posible componer los grupos de mando con facilidad, sin el uso de herramientas y de acuerdo con las exigencias del instalador.

Comenzando por una válvula individual o por un grupo monocuerpo de 3 vías, es posible aumentar el número agregando otros módulos con empalme de horquilla T5.

El grupo puede ser terminado a discreción del usuario con los empalmes para completar con horquilla T5 y salida T3.

- Disponibles en versión con o sin retornos calibrados.
- **El alojamiento de la estanqueidad válvula sustituible es independiente del empalme de salida.**
- Sistema de fijación integrado patentado; no necesita tirantes de ensamblado ni sostenes de soporte.
- Compatibles con todos los componentes ARAG con empalme de horquilla T5.
- Amplia gama de empalmes de horquilla de salida T3.
- Estructura de Nylon reforzada con fibra de vidrio.
- Componentes internos de Delrin® y acero Inoxidable AISI 303
- Válvulas suministradas completas, con juntas tóricas de Viton® y horquillas.
- Juntas tóricas y horquillas T5 y T3 para completar, se deben pedir por separado.

La manutenzione è un'operazione semplicissima: una volta rimossi forchetta e gruppo motore dalla sede, quest'ultima può essere sostituita semplicemente sfilandola. Il perno si toglie svitandolo per sostituirlo con uno nuovo.

Easy maintenance: once fork and motor unit are removed from their seat, the latter can be replaced by simply pulling it out. Unscrew the pin to remove and replace it with a new one.

El mantenimiento es una operación muy simple: una vez que se ha extraído la horquilla y el grupo motor de su alojamiento, esta última puede ser sustituida simplemente extrayéndola. El perno se extrae desatornillándolo para sustituirlo por uno nuevo.

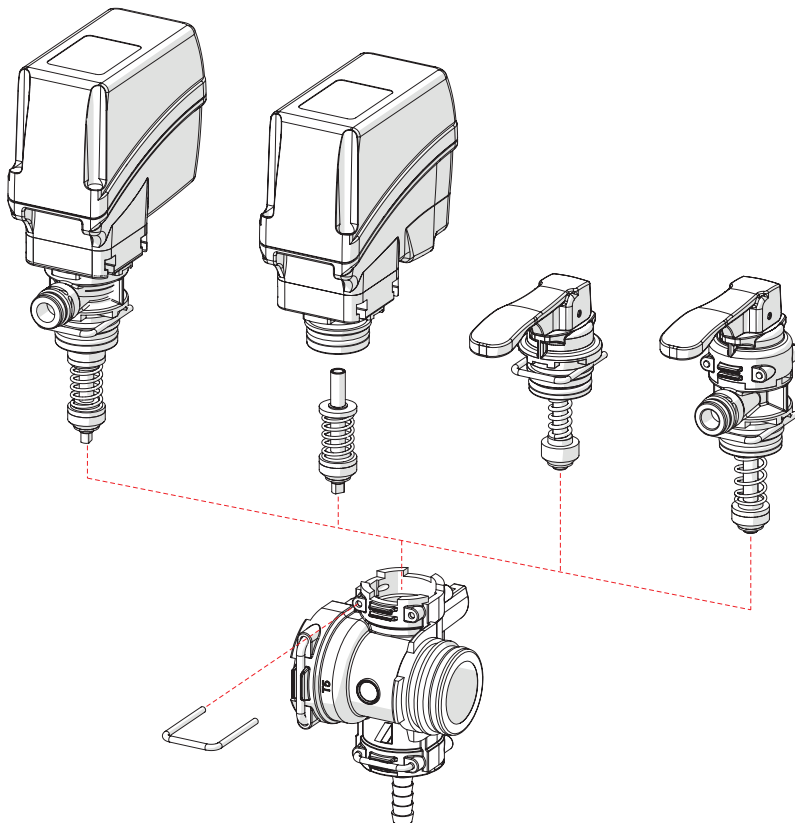

La connessione tra azionamento e corpo valvola è assicurata da un attacco a forchetta per rendere molto semplice la manutenzione.

Actuator and valve body are connected by a fork coupling to facilitate maintenance operations.

La conexión entre accionamiento y cuerpo válvula está asegurada por una toma de horquilla para que el mantenimiento sea muy simple.

# 863T - 463T

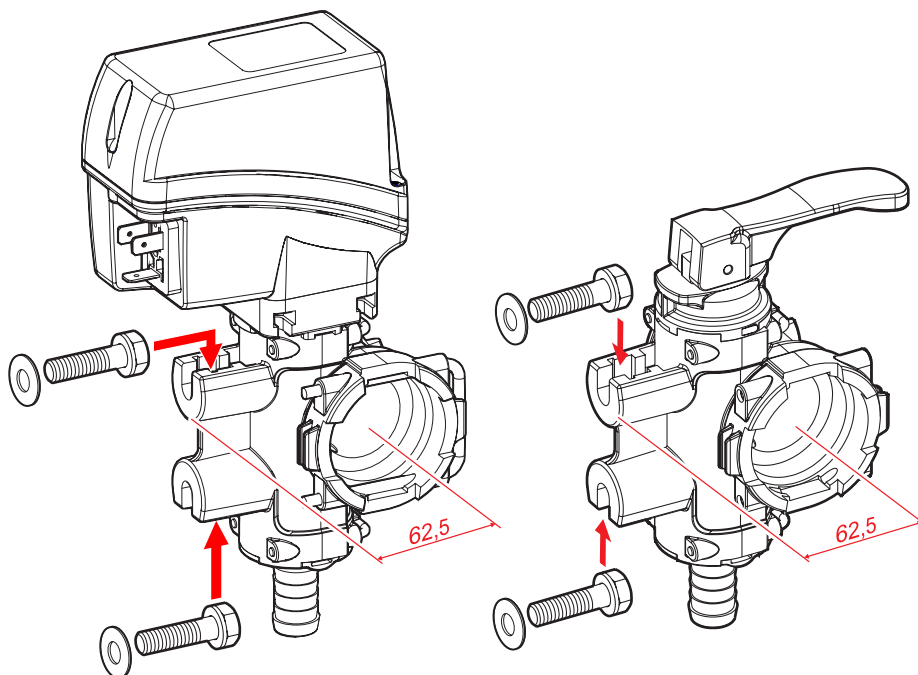

Le valvole delle serie 463T e 863T sono dotate di un sistema di fissaggio integrato direttamente nel corpo valvola, che si ottiene mediante due viti TE M8 (o 5/16 UN) e due rondelle e mantiene la medesima distanza delle staffe metalliche normalmente utilizzate con le altre valvole ARAG, così da consentire la compatibilità con gruppi standard di produzione precedente (passo 62,5 mm).

The 463T and 863T series valves are provided with a fixing system integrated directly in the valve body, consisting in two M8 (or 5/16 UN) hexagon-head screws and two washers. The distance of the metal brackets is the same used with other ARAG valves, in order to ensure perfect compatibility with previous version standard units (step 62.5 mm).

Las válvulas serie 463T y 863T están dotadas de un sistema de fijación integrado directamente al cuerpo de la válvula, que se obtiene a través de dos tornillos TE M8 (o 5/16 UN) y dos arandelas y mantiene la misma distancia de los sostenes metálicos normalmente utilizados con las otras válvulas ARAG, para garantizar de esta manera una perfecta compatibilidad con grupos estándar de producción anterior (paso 62,5 mm).

# 863T - 863

## Funzionamento a 3 fili

- Alimentazione 12 Vdc sempre collegata
- Alimentando il comando di apertura/chiusura a 12 Vdc la valvola si apre.
- Togliendo tensione al comando, la valvola si chiude.

## 3-wire operation

- 12 Vdc power supply always on
- Valve opens when opening/closing control is fed with 12 Vdc.
- Valve closes when control power is cut.

## Funcionamiento de 3 cables

- Alimentación 12 Vcc siempre conectada
- Alimentando el mando de apertura/cierre de 12 Vcc, la válvula se abre.
- Quitando tensión al mando, la válvula se cierra.

## Funzionamento a 2 fili

- Movimento di apertura/chiusura ottenuto invertendo la polarità di alimentazione con un doppio deviatore.

## 2-wire operation

- Opening/closing movement obtained by reversing power polarity with a double switch.

## Funcionamiento de 2 cables

- Movimiento de apertura/cierre obtenido invirtiendo la polaridad de alimentación con un doble conmutador.

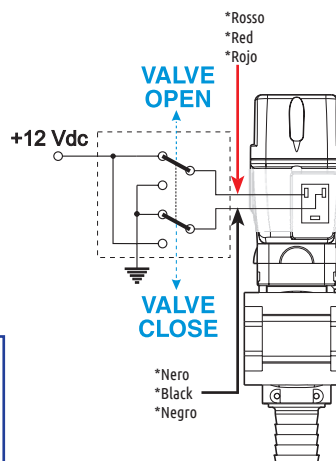
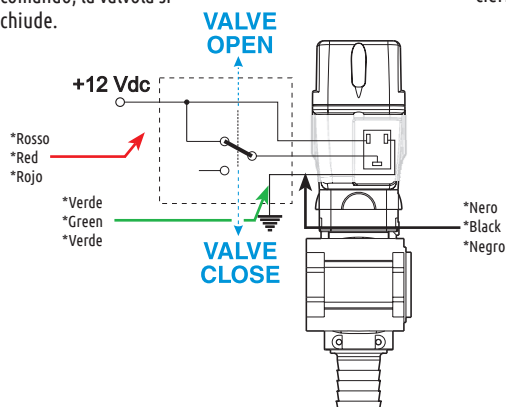

\*I colori dei fili sono riferiti al cavo  
 COD. 8650900.140  
 \*The wire colours refer to the cable  
 COD. 8650900.140  
 \*Los colores de los hilos se refieren al cable  
 COD. 8650900.140

In entrambi i casi il motore assorbe corrente solo durante il movimento della valvola.

In both cases, the motor absorbs current only during the valve movement.

En ambos casos, el motor absorbe corriente solo durante el movimiento de la válvula.

# LA SCELTA DEI GRUPPI DI COMANDO CON ATTACCO A FORCHETTA THE CHOICE OF CONTROL UNITS WITH FORK COUPLING LA ELECCIÓN DE LOS GRUPOS DE MANDO CON EMPALME DE HORQUILLA

I gruppi di comando con attacco a forchetta sono il frutto di una lunga progettazione mirata alla funzionalità e alla riduzione dei costi di gestione grazie alla possibilità di configurare le parti per creare un gruppo ad hoc come in un gioco di mattoncini.

Ogni parte del gruppo, dalle valvole, ai flussometri, ai raccordi di completamento, agli accessori è assolutamente intercambiabile e componibile a piacere. I fissaggi integrati nelle valvole consentono di posizionare il gruppo senza staffe di supporto.

Da adesso ogni progettista o utilizzatore può davvero configurare un gruppo di comando sulle proprie esigenze senza vincoli e con la qualità che da sempre contraddistingue i prodotti ARAG.

## Sistema componibile per gruppi di comando

- Minori costi di gestione delle scorte
- Maggiore rapidità di risposta al cliente
- Flessibilità di impiego
- Facile manutenzione

The control units with fork coupling are the result of a special design focused on functionality and management costs reduction thanks to the possibility to set up the components to create an ad hoc unit as in a brick game. Each part of the unit, from valves to flowmeters, end fittings and accessories is completely interchangeable and can be composed at will.

Thanks to the fixing devices integrated in the valves, the unit can be positioned without supporting brackets. From now on any designer or user can set up the control unit according to their needs without restraints and with the quality that has always distinguished ARAG's products.

## Modular system for control units

- Reduction of stock management costs
- Quicker reply to the customer
- Flexibility of use
- Easy maintenance

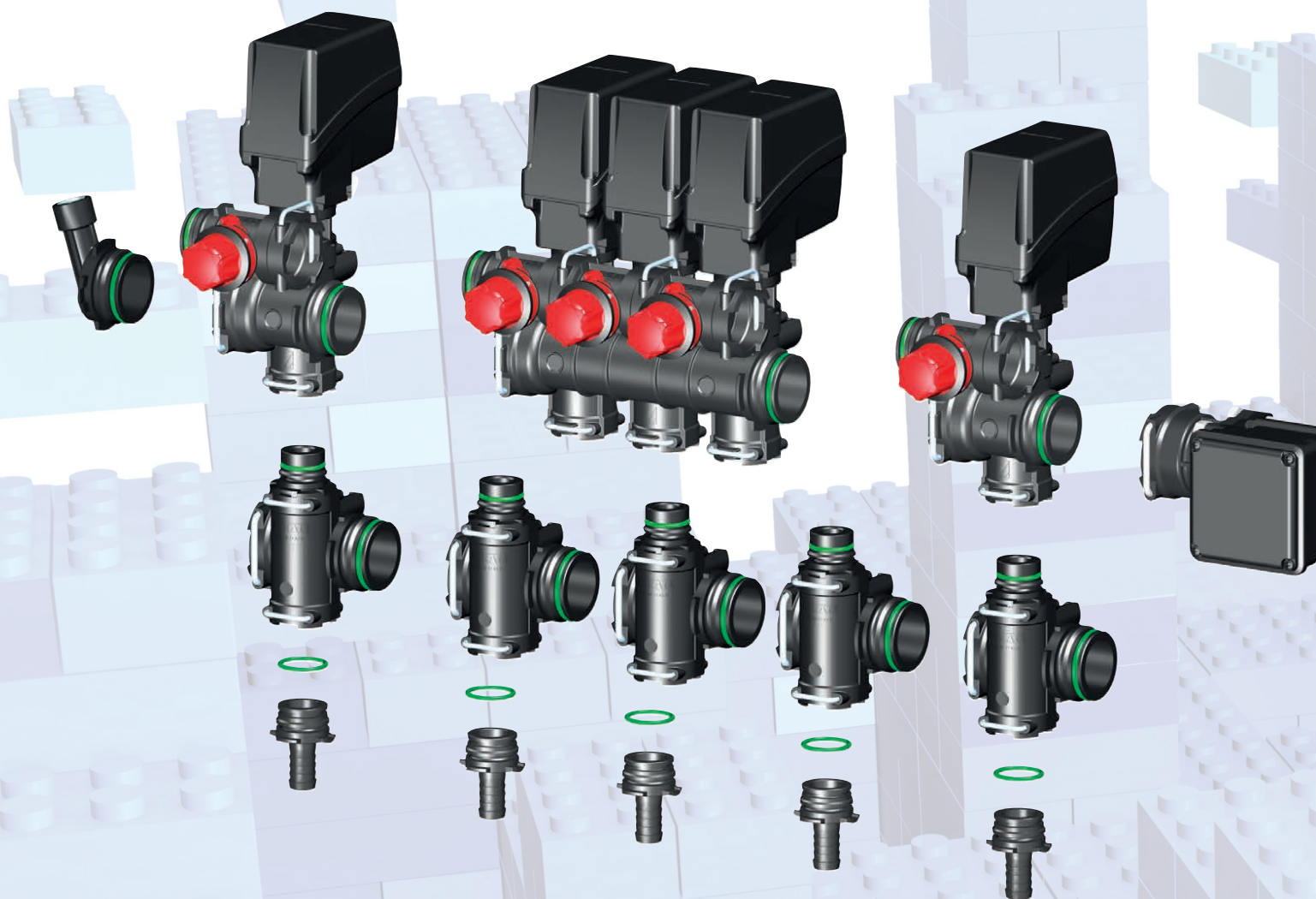

Los grupos de mando con empalme de horquilla son el resultado de un prolongado estudio de diseño dirigido al funcionamiento y a la reducción de los costes de gestión gracias a la posibilidad de configurar las partes para crear un grupo específico como en un juego de bloques.

Cada parte del grupo, desde las válvulas, hasta los medidores de caudal, a los empalmes para completar, a los accesorios, es completamente intercambiable y se puede componer según la preferencia.

Las fijaciones integradas en las válvulas permiten posicionar el grupo sin sostenes de soporte.

Desde ahora cada diseñador o usuario puede realmente configurar un grupo de mando según sus exigencias sin vínculos y con la calidad que desde siempre ha caracterizado a los productos ARAG.

#### Sistema para componer para grupos de mando

- Menores costes de gestión de las existencias
- Mayor velocidad de respuesta al cliente
- Flexibilidad de empleo
- Fácil mantenimiento

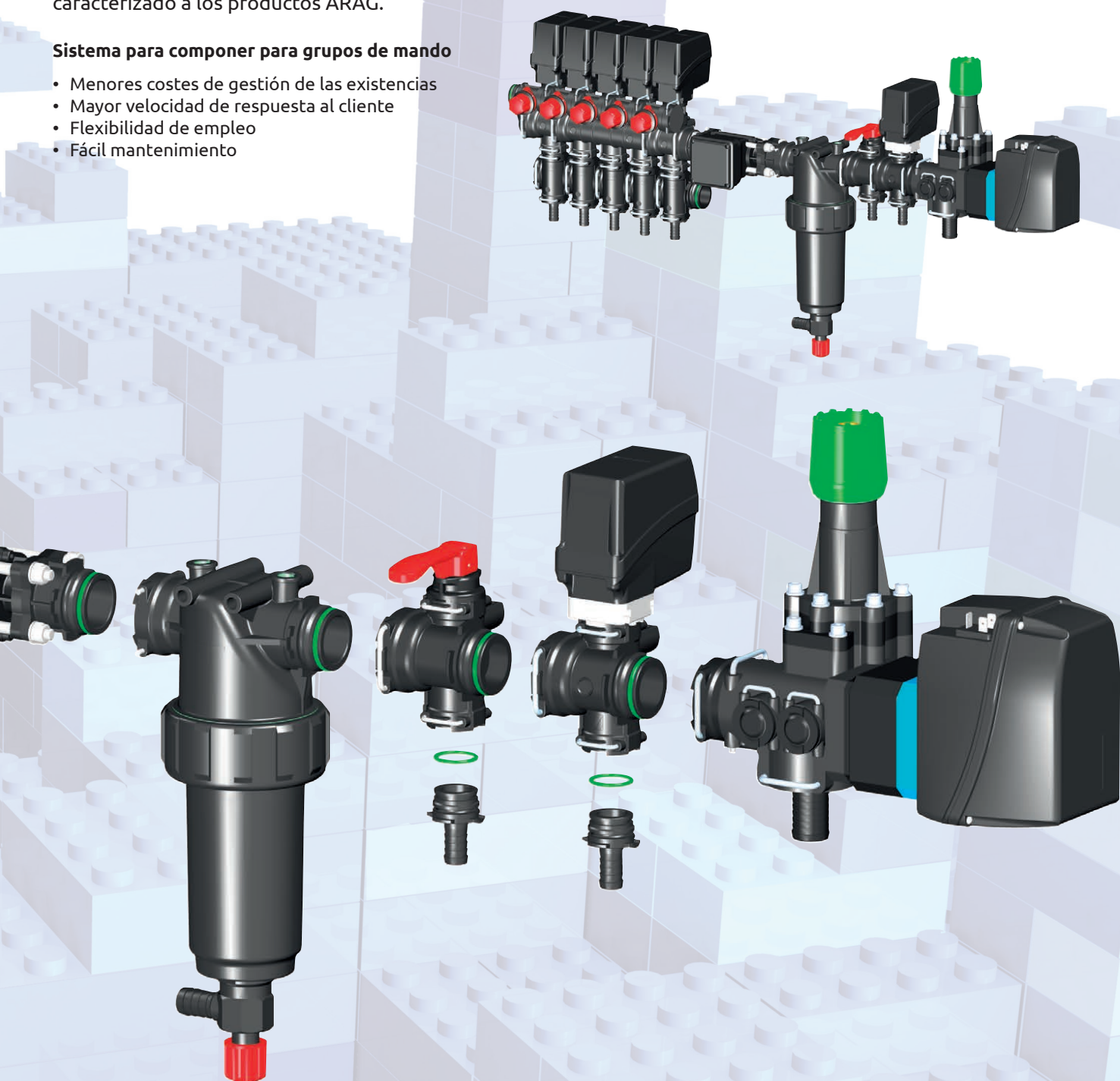

# GRUPPI DI COMANDO componibili con attacco a FORCHETTA FORK COUPLING MODULAR CONTROL UNITS GRUPOS DE MANDOS MODULARES con ENPALME DE HORQUILLA

## Sistema componibile per gruppi di comando

- Minori costi di gestione delle scorte
- Flessibilità di impiego
- Maggiore rapidità di risposta al cliente

## Modular system for control units

- Lower management cost of the supply
- Flexibility of use
- Shorter response time to the customer

## Sistema modulare para grupos de mandos

- Menor costo de gestión de las existencias
- Flexibilidad de empleo
- Mayor rapidez de respuesta al cliente

Gruppi valvole di sezione serie 863 elettriche e 463 manuali.  
Series 863 and 463 section valves, with electric and manual controls.  
Grupos válvulas de sección serie 863 eléctricas y 463 manuales.

**Pag. - Page - Pág. B-20**

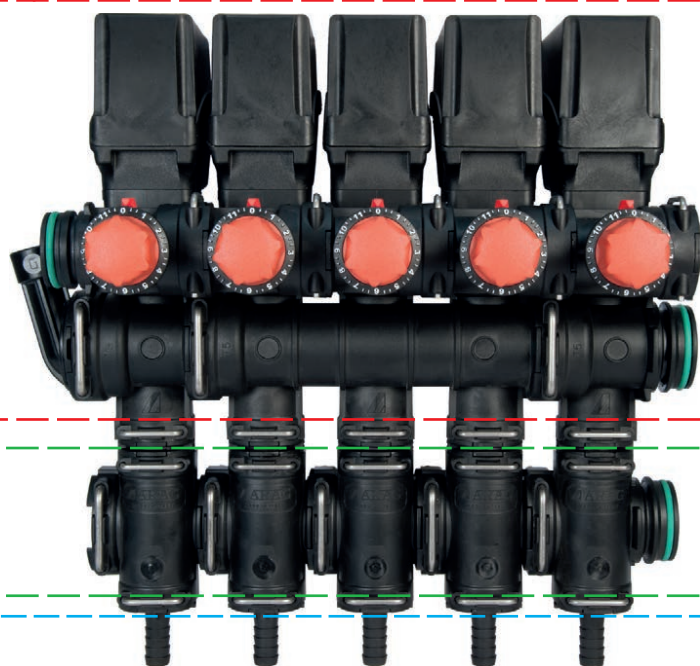

Raccordi di uscita con attacco a forchetta T3 da ordinare separatamente nel capitolo:  
Output fitting with T3 fork coupling to be ordered separately in chapter:  
Empalme de salida con toma de horquilla T3 para pedir por separado en el capítulo:

**FITTINGS**

Collettori con valvola di scarico pressione  
Manifold with bleeder valve  
Colectores con válvula de descarga presión

**Pag. - Page - Pág. B-22**

Flussometri elettromagnetici ORION2.  
ORION2 electromagnetic flow-meters.  
Caudalímetros electromagnéticos ORION2.

**Pag. - Page - Pág. B-18**



Flussometri a palette WOLF.  
WOLF paddle flow-meter.  
Caudalímetros de paletas WOLF.

**Pag. - Page - Pág. B-18**







Filtri in linea serie 322 e 326 con attacco a forchetta, con e senza valvola di scarico.  
Series 322 and 326 line filters with fork connections, with and without drain valve.  
Filtros en línea serie 322 y 326 con empalme con acople de horquilla, con o sin válvula de descarga.

**Pag. - Page - Pág. B-19**



Valvola proporzionale serie 863 con attacco a forchetta T5.  
Series 863 proportional valve with T5 fork connector.  
Válvula proporcional serie 863 con empalme de horquilla T5.

**Pag. - Page  
Pág. B-14**



Gruppo valvola generale serie 871.  
Series 871 main valve.  
Grupo válvula general serie 871.

**Pag. - Page  
Pág. B-10**



Valvola proporzionale serie 863 con attacco a forchetta T5.  
Series 863 proportional valve with T5 fork connector.  
Válvula proporcional serie 863 con empalme de horquilla T5.

**Pag. - Page  
Pág. B-14**



Gruppo valvola generale serie 864 con attacco a forchetta T5.  
Series 864 main valve unit with T5 fork connector.  
Grupo válvula general serie 864 con empalme de horquilla T5.

**Pag. - Page - Pág. B-12**

# VALVOLE DI COMANDO GENERALE MAIN CONTROL VALVES VÁLVULAS DE MANDO GENERAL

# 871T - 471T T5

## Valvola di comando generale con valvola di massima pressione regolabile e attacco a forchetta T5

- Struttura in Nylon® rinforzato con fibra di vetro
- Particolari interni in Delrin® e acciaio Inox AISI 303
- Guarnizioni in Viton®
- Basso assorbimento di corrente



## Main control valve with adjustable max. pressure valve and T5 fork-connection

- Fibreglass-reinforced Nylon body
- Internal parts in Delrin® and AISI 303 stainless steel
- Gaskets made of Viton®
- Low power consumption

## Válvula de mando general de accionamiento eléctrico con válvula de presión máxima regulable y empalme con acople de horquilla T5

- Estructura de Nylon reforzado con fibra de vidrio
- Piezas interiores de Delrin® y acero Inox AISI 303
- Juntas de Viton®
- Bajo consumo de amperaje

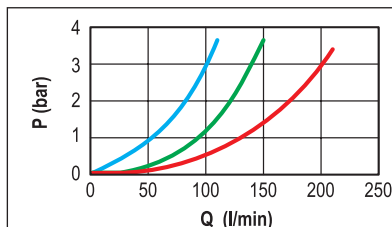

Pressione residua valvola in scarico (portagomma con risucchio).  
Back pressure during dump phase (hose tail with suck back device).  
Presión residual durante la descarga (racor portamanguera con reaspiracion).

Ø BY PASS:	<span style="color: blue;">■</span> 25 mm
	<span style="color: green;">■</span> 30-32 mm - 1" 1/4
	<span style="color: red;">■</span> 35 mm - 1" 1/4

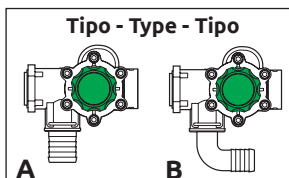

Cavi e spine DIN a 3 fili  
3-wires DIN cables and plugs  
Cables y tomas DIN a 3 hilos

COD. / CODE / CÓD.	ECS0033
--------------------	---------

COD. / CODE / CÓD.	8650900.140 (1.3 m)
--------------------	---------------------

COD. CODE / CÓD.	Pressure		ON-OFF	Flow		Ø IN		Ø BY PASS	
	bar	PSI		lt/1'	US GPM	mm	type		
871T 501	10	145	0.6 sec.	12 Vdc 0.5 A	150	40	19	A	25 30 32 35 1" 1/4 (♦♦)
871T 502	20	290					25	A - B	
			30	A					
			32	A					
			3/4"	A					
			1"	A					
			1" 1/4	A					

	A	B	C
mm	239	135	246
inches	9.4	5.3	9.7

## Valvola di comando generale con valvola di massima pressione regolabile e attacco a forchetta T5

- Struttura in Nylon® rinforzato con fibra di vetro
- Particolari interni in Delrin® e acciaio Inox AISI 303
- Guarnizioni in Viton®

## Main manual control valve with adjustable max. pressure valve and T5 fork connector

- Fibreglass-reinforced Nylon body
- Internal parts in Delrin® and AISI 303 stainless steel
- Gaskets made of Viton®

## Válvula de mando general de accionamiento manual con válvula de presión máxima regulable y empalme con acople de horquilla T5

- Estructura de Nylon reforzado con fibra de vidrio
- Piezas interiores de Delrin® y acero Inox AISI 303
- Juntas de Viton®

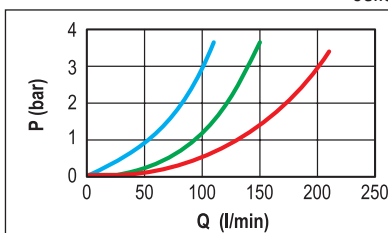

Pressione residua valvola in scarico (portagomma con risucchio).  
Back pressure during dump phase (hose tail with suck back device).  
Presión residual durante la descarga (racor portamanguera con reaspiracion).

Ø BY PASS:	<span style="color: blue;">■</span> 25 mm
	<span style="color: green;">■</span> 30-32 mm - 1" 1/4
	<span style="color: red;">■</span> 35 mm - 1" 1/4



	A	B	C
mm	235	135	246
inches	9.3	5.3	9.7

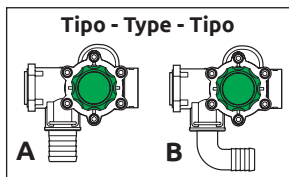

COD. CODE / CÓD.	Pressure		Flow	Ø IN		Ø BY PASS	
	bar	PSI		mm	type		
471T 201	10	145	150	40	19	A	25 30 32 35 1" 1/4 (♦♦)
471T 202	20	290			25	A - B	
			30	A			
			32	A			
			3/4"	A			
			1"	A			
			1" 1/4	A			

- ♦ Massimo portata della valvola di massima pressione a 3 bar / 45 PSI (portagomma con Venturi).
- ♦ Maximum flow rate of the relief valve at 3 bar / 45 PSI (hose tail with Venturi)
- ♦ Máximo caudal de la válvula de presión máx. a 3 bar / 45 PSI (racor puerta manguera con Venturi)

♦♦ Ø e colore del portagomma by-pass in funzione della portata pompa.

♦♦ Ø and colour of the by-pass hose fitting depend on the pump case.

♦♦ Ø y color del portamanguera by-pass en función del caudal de la bomba.

Ø BY PASS (mm)	lt/1'	MAX POMPA / PUMP US GPM
25	70	19
30-32 - 1" 1/4	120	32
35 - 1" 1/4	180	48

Specificare il diametro dei portagomma indicati in tabella.

Specify the diameter of the hose fittings indicated in the table.

Especifiquen el diámetro de los portamangueras indicados en la tabla.

# 871T - 471T

ACCESSORI PER VALVOLE MODULARI  
ACCESSORIES FOR MODULAR VALVES  
ACCESORIOS PARA VÁLVULAS MODULARES

## 471T 871T

**T5**  
fork  
coupling

COD. / CODE / CÓD.	Ø	Ør
471 202.B50	G 1 1/4 (BSP)	
471 202.B51	G 1 1/4 (BSP)	● 19 mm
471 202.B52	G 1 1/4 (BSP)	● 16 mm

Ør  
diametro interno portagomma con venturi  
hose tail with venturi internal diameter  
diámetro interior racor porta manguera con venturi

COD. CODE CÓD.	Ø
471 202.C25	25 mm
471 202.C30	30 mm

COD. CODE CÓD.	Ø
473 001.C25C	25 mm

COD. / CODE / CÓD.	Ø		MAX POMPA PUMP	
			lt/1'	US GPM
471 202.A40	25 mm	●	70	19
471 202.A41	30 mm	●	120	32
471 202.A43	32 mm	●	120	32
471 202.A45	35 mm	●	180	48

COD. CODE CÓD.	Ø
473 001.A19C	19 mm
473 001.A25C	25 mm
473 001.A30C	30 mm
473 001.A32C	32 mm

COD. CODE CÓD.	Ø
473 001.B30C	G 3/4 (BSP)
473 001.B40C	G 1 (BSP)
473 001.B50C	G 1 1/4 (BSP)

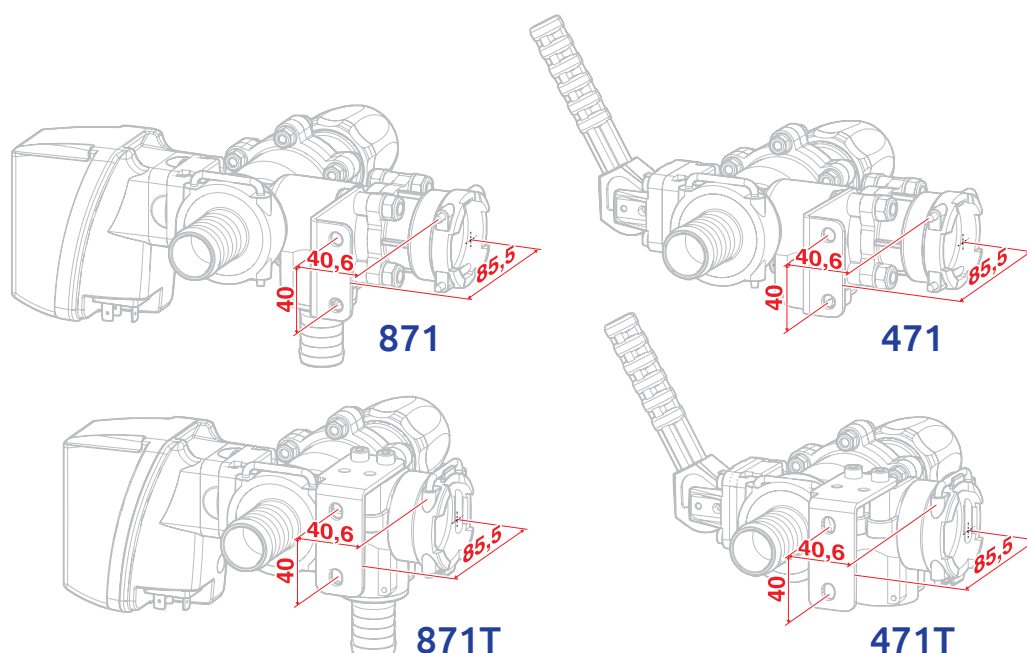

I punti di fissaggio e le distanze di connessione delle valvole con attacco a forchetta serie 471T e 871T sono pienamente compatibili con le serie 471 e 871 e non necessitano di modifiche in fase di sostituzione.

The retaining points and the connection distances of 471T and 871T series valves with fork coupling are completely compatible with series 471 and 871 and do not require changes during replacement.

Los puntos de fijación y las distancias de conexión de las válvulas con empalme de horquilla serie 471T y 871T son completamente compatibles con las series 471 y 871 y no necesitan modificaciones en fase de sustitución.

# VALVOLE DI COMANDO GENERALE MAIN CONTROL VALVES VÁLVULAS DE MANDO GENERAL

# 864 - 464 T5

## Valvola di comando generale con valvola di massima pressione regolabile e attacco a forchetta T5

- Struttura in Nylon® rinforzato con fibra di vetro
- Particolari interni in Delrin® e acciaio Inox AISI 303
- Guarnizioni in Viton®



## Main control valve with adjustable max. pressure valve and T5 fork-connection

- Fibreglass-reinforced Nylon body
- Internal parts in Delrin® and AISI 303 stainless steel
- Gaskets made of Viton®

## Válvula de mando general con válvula de presión máxima regulable y empalme con acople de horquilla T5

- Estructura de Nylon reforzado con fibra de vidrio
- Piezas interiores de Delrin® y acero Inox AISI 303
- Juntas de Viton®

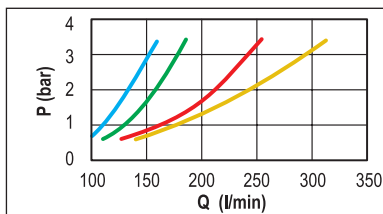

Pressione residua valvola in scarico (portagomma con risucchio).  
Back pressure during dump phase (hose tail with suck back device).  
Presión residual durante la descarga (racor portamanguera con reaspiración).

Ø BY PASS:	35 mm	35 mm
	35 mm	40 mm

COD. CODE CÓD.	Pressure		ON-OFF	Voltage	Flow	US GPM	Ø	
	bar	PSI					IN	BY PASS
864 050150	10	145	1 sec.	12 Vdc 3 A	200	53	25	35 40
864 050250	20	290					30	35

	A	B	C
mm	270	309	175
inches	10.6"	12.2"	6.9"

Cavi e spine DIN a 3 fili  
3-wires DIN cables and plugs  
Cables y tomas DIN a 3 hilos

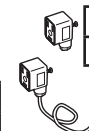

COD. / CODE / CÓD.  
ECS0033

COD. / CODE / CÓD.  
8650900.140 (1.3 m)

## Valvola di comando generale con valvola di massima pressione regolabile e attacco a forchetta T5

- Struttura in Nylon® rinforzato con fibra di vetro
- Particolari interni in Delrin® e acciaio Inox AISI 303
- Guarnizioni in Viton®



## Main control valve with adjustable max. pressure valve and T5 fork connector

- Fibreglass-reinforced Nylon body
- Internal parts in Delrin® and AISI 303 stainless steel
- Gaskets made of Viton®

## Válvula de mando general con válvula de presión máxima regulable y empalme con acople de horquilla T5

- Estructura de Nylon reforzado con fibra de vidrio
- Piezas interiores de Delrin® y acero Inox AISI 303
- Juntas de Viton®

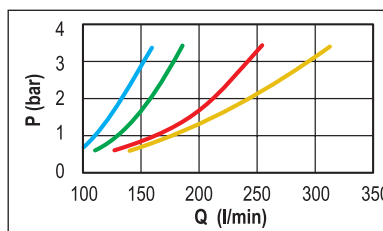

Pressione residua valvola in scarico (portagomma con risucchio).  
Back pressure during dump phase (hose tail with suck back device).  
Presión residual durante la descarga (racor portamanguera con reaspiración).

Ø BY PASS:	35 mm	35 mm
	35 mm	40 mm

COD. CODE CÓD.	Pressure		Flow	US GPM	Ø	
	bar	PSI			IN	BY PASS
464 20150	10	145	200	53	25	35 40
464 20250	20	290			30	35

	A	B	C
mm	214-388	299	171
inches	8.5"-15"	11.8"	6.7"

- ◆ massima portata della valvola di massima pressione a 3 bar / 45 PSI (portagomma con Venturi).
- ◆ maximum flow rate of the relief valve at 3 bar / 45 PSI (hose tail with Venturi)
- ◆ máximo caudal de la válvula de presión máx. a 3 bar / 45 PSI (racor puerta manguera con Venturi)

- ◆◆ Ø e colore del portagomma by-pass in funzione della portata pompa.
- ◆◆ Ø and colour of the by-pass hose fitting depend on the pump case.
- ◆◆ Ø y color del portamanguera by-pass en función del caudal de la bomba.

Ø BY PASS (mm)	MAX POMP / PUMP (l/1' / US GPM)
35	60 / 16
	120 / 32
	180 / 48
40	280 / 74

Specificare il diametro dei portagomma indicati in tabella.  
Specify the diameter of the hose fittings indicated in the table.  
Especificar el diámetro de los portamangueras indicados en la tabla.

# 864 - 464

## ACCESSORI PER VALVOLE MODULARI ACCESSORIES FOR MODULAR VALVES ACCESORIOS PARA VÁLVULAS MODULARES

**T5**  
fork  
coupling

**464**  
**864**

COD. CODE CÓD.	Ø	MAX POMPA / PUMP	
		lt/1'	US GPM
<b>464 402.A40</b>	35 mm	60	16
<b>464 402.A41</b>	35 mm	120	32
<b>464 402.A42</b>	35 mm	180	48
<b>464 402.A43</b>	40 mm	280	74

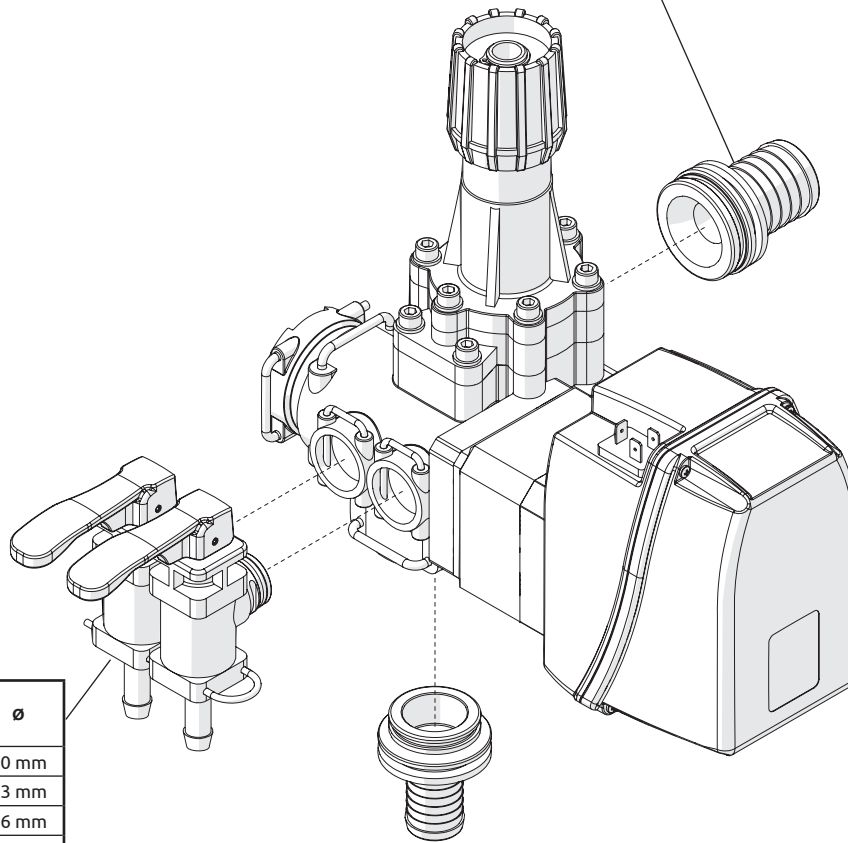

COD. CODE CÓD.	Ø
<b>464 402.150</b>	10 mm
	13 mm
	16 mm
	19 mm
	25 mm

COD. CODE CÓD.	Ø
<b>464 402.A90</b>	25 mm
<b>464 402.A91</b>	30 mm
<b>464 402.A92</b>	35 mm
<b>464 402.A93</b>	38 mm

# VALVOLE DI REGOLAZIONE PROPORZIONALE PROPORTIONAL CONTROL VALVES VÁLVULAS DE REGULACIÓN PROPORCIONAL

# 863T

## Valvola di regolazione proporzionale elettrica

- Regola il flusso nei gruppi di distribuzione che effettuano trattamenti proporzionali ai giri motore (DPM)
- Struttura in Nylon® rinforzato con fibra di vetro
- Particolari interni in Delrin® e acciaio Inox AISI 303
- Guarnizioni in Viton®
- Fusibile interno resettabile (togliendo l'alimentazione per 20 secondi)

## Electric proportional control valve

- Adjusts the flow in the control units in which treatments vary in proportion with engine rpm (DPM)
- Fibreglass-reinforced Nylon body
- Internal parts in Delrin® and AISI 303 stainless steel
- Gaskets made of Viton®
- Internal resettable fuse (disconnecting power for 20 seconds)

## Válvula de regulación proporcional eléctrica

- Regula el flujo en los grupos de distribución que efectúan tratamientos proporcionales a las revoluciones del motor (DPM)
- Estructura de Nylon reforzado con fibra de vidrio
- Piezas interiores de Delrin® y acero Inox AISI 303
- Juntas de Viton®
- Fusible interior rearmable (parando l'alimentacion para 20 sec.)

## Valvola di regolazione proporzionale elettrica



## Electric proportional control valve

## Válvula de regulación proporcional eléctrica

COD. CODE CÓD.	Pressure		ON-OFF	12 Vdc 0.5 A	Flow		Ø*	
	bar	PSI			lt/1'	US GPM	mm	inches
<b>863T 026</b>	20	290	14 sec.	12 Vdc 0.5 A	25	6	13	1/2"
<b>863T 022</b>					60	16	13	1/2"
<b>863T 020</b>					100	26	19	3/4"
<b>863T 024</b>					150	40	25	1"
<b>863T 028</b>					180	48	25	1"
<b>863T 026S</b>	20	290	7 sec.	12 Vdc 0.5 A	25	6	13	1/2"
<b>863T 022S</b>					60	16	13	1/2"
<b>863T 020S</b>					100	26	19	3/4"
<b>863T 024S</b>					150	40	25	1"
<b>863T 028S</b>					180	48	25	1"

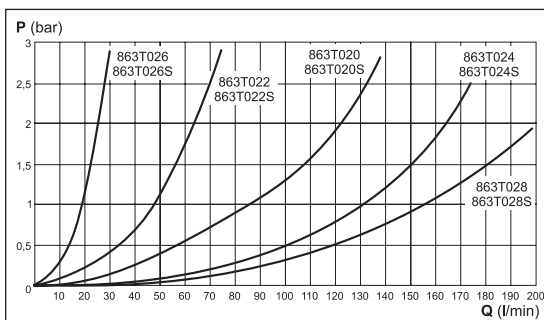
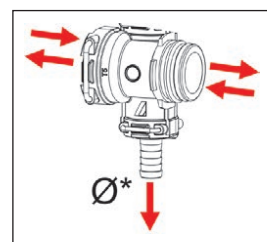

Caduta di pressione con valvola tutta aperta

Pressure drop with fully open valve

Caída de presión con válvula toda abierta

A	B	C	
mm	81	230	109
inches	3.2	9.1	4.3

Cavi e spine DIN a 3 fili  
3-wires DIN cables and plugs  
Cables y tomas DIN a 3 hilos

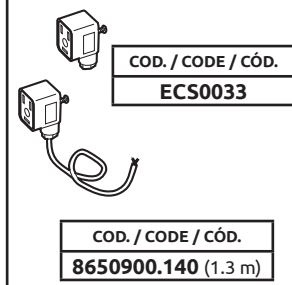

Valvola specifica per l'utilizzo con i computer BRAVO e DELTA: nuovo sistema di azionamento a diametro maggiorato, con trattamento antiusura per garantire una lunga durata.

Specific valve for use with BRAVO and DELTA computers: new larger-diameter drive system, with wear-proof coating for a longer life.

Válvula específica para el uso con los ordenadores BRAVO y DELTA: nuevo sistema de accionamiento de mayor diámetro, con tratamiento anti desgaste para garantizar una prolongada durabilidad.

## Valvola di regolazione proporzionale manuale



## Manual proportional control valve

## Válvula de regulación proporcional manual

COD. CODE CÓD.	Pressure		Flow	Ø*		
	bar	PSI		mm	inches	
<b>463T 072</b>	20	290	60	16	13	1/2"
<b>463T 070</b>			100	26	19	3/4"
<b>463T 074</b>			150	40	25	1"
<b>463T 078</b>			180	48	25	1"



A	B	C	
mm	81	225	109
inches	3.2	8.9	4.3

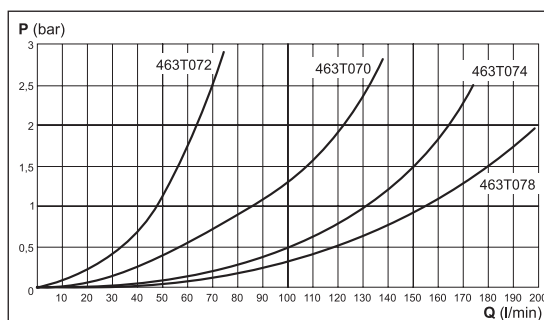
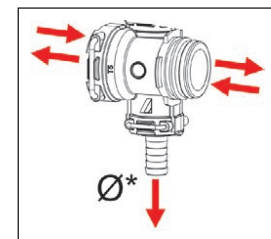

Caduta di pressione con valvola tutta aperta

Pressure drop with fully open valve

Caída de presión con válvula toda abierta

### Valvola di regolazione proporzionale elettrica

- Dimensioni compatte
- Regola il flusso nei gruppi di distribuzione che effettuano trattamenti proporzionali ai giri motore (DPM)
- Struttura in Nylon® rinforzato con fibra di vetro
- Particolari interni in Delrin® e acciaio Inox AISI 303
- Guarnizioni in Viton®
- Fusibile interno resettabile (togliendo l'alimentazione per 20 secondi)

### Electric proportional control valve

- Compact sizes
- Adjusts the flow in the control units in which treatments vary in proportion with engine rpm (DPM)
- Fibreglass-reinforced Nylon body
- Internal parts in Delrin® and AISI 303 stainless steel
- Gaskets made of Viton®
- Internal resettable fuse (disconnecting power for 20 seconds)

### Válvula de regulación proporcional eléctrica

- Tamaños compactos
- Regula el flujo en los grupos de distribución que efectúan tratamientos proporcionales a las revoluciones del motor (DPM)
- Estructura de Nylon reforzado con fibra de vidrio
- Piezas interiores de Delrin® y acero Inox AISI 303
- Juntas de Viton®
- Fusible interior rearmable (parando l'alimentacion para 20 sec.)



COD. CODE COD.	bar	PSI	sec.	12 Vdc 3 A	lt/1' US GPM	Ø1	Ø2	Ø BY PASS
875 46150S	15	220	7	12 Vdc 3 A	320 85	T6 F	T6 F	T6 F



Valvola specifica per l'utilizzo con i computer BRAVO e DELTA: nuovo sistema di azionamento a diametro maggiorato, con trattamento antiusura per garantire una lunga durata.

Specific valve for use with BRAVO and DELTA computers: new larger-diameter drive system, with wear-proof coating for a longer life.

Válvula específica para el uso con los ordenadores BRAVO y DELTA: nuevo sistema de accionamiento de mayor diámetro, con tratamiento anti desgaste para garantizar una prolongada durabilidad.



		A	B	C
mm		170	220	119
inches		6.7"	8.7"	4.7"

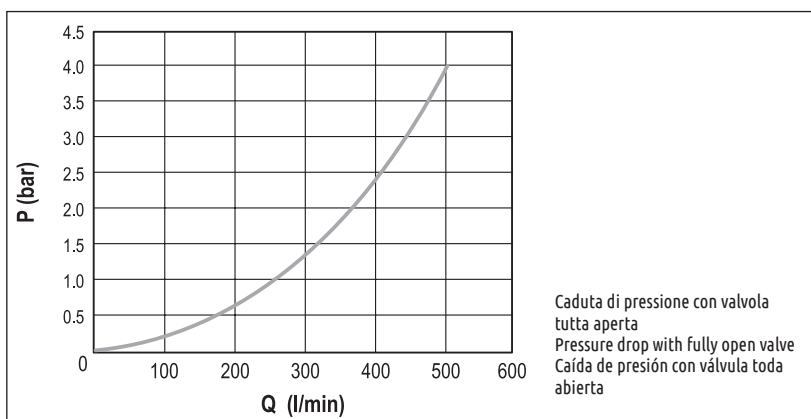
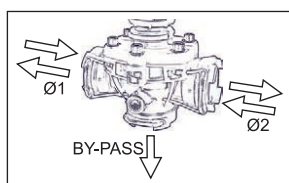

Accessori di completamento nel capitolo:  
Accessories available in chapter:  
Accesorios de terminación en el capítulo:

### FITTINGS

Cavi e spine DIN  
DIN cables and plugs  
Cables y tomas DIN

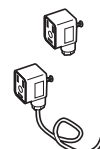

COD. / CODE / CÓD.  
**ECS0033**

COD. / CODE / CÓD.  
**8650900.140 (1.3 mt)**

# VALVOLE DI REGOLAZIONE MASSIMA PRESSIONE PRESSURE RELIEF CONTROL VALVES VÁLVULAS DE REGULACIÓN MAXIMA PRESIÓN

# 475

- Bypassa il liquido in eccesso e consente di mantenere costante la pressione di linea
- Con membrana di separazione per una migliore sensibilità di regolazione
- Struttura in Nylon® rinforzato con fibra di vetro
- Particolari interni in Delrin® e acciaio Inox AISI 303
- Guarnizioni in Viton®

- By-passes the excess liquid and maintains constant line pressure
- Equipped with a separation diaphragm for enhanced control sensitivity
- Fibreglass reinforced Nylon body
- Internal parts in Delrin® and AISI 303 stainless steel
- Gaskets made of Viton®

- Deriva el líquido en exceso y permite mantener constante la presión de línea
- Con membrana de separación para mayor sensibilidad de regulación
- Estructura de Nylon reforzado con fibra de vidrio
- Piezas interiores de Delrin® y acero Inox AISI 303
- Juntas de Viton®

La clip estraibile permette di bloccare la valvola 475 alla pressione impostata.

The removable clip allows to block the valve 475 at the set pressure.

El clip extraíble permite bloquear la válvula 475 a la presión establecida.



Valvola di regolazione massima pressione manuale a membrana, attacco a forchetta

Manual diaphragm pressure relief control valve with fork coupling

Válvula de regulación máxima presión manual de membrana con conexión de horquilla



COD. CODE CÓD.	⌚		🔑 @ 3 bar @ 40 PSI		Ø1	Ø2	Ø BY PASS
	bar	PSI	lt/1'	US GPM			
475 551	10	145	200	53	T5 F	T5 F	T5 F
475 552	20	290					

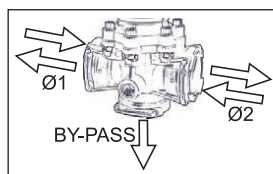

	A	B	C
mm	114	210	91
inches	4,5"	8,3"	3,6"

Valvola di regolazione massima pressione manuale a membrana, attacco a forchetta

Manual diaphragm pressure relief control valve with fork coupling

Válvula de regulación máxima presión manual de membrana con conexión de horquilla



## HI-FLOW

450 l/min

COD. CODE CÓD.	⌚		🔑 @ 3 bar @ 40 PSI		Ø1	Ø2	Ø BY PASS
	bar	PSI	lt/1'	US GPM			
475 560	8	116	450	120	T6 F	T6 F	T6 F
475 5612	12	174					

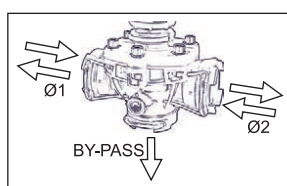

	A	B	C
mm	158	218	119
inches	6,3"	8,6"	4,7"

F= femmina  
M= maschio  
T= attacco a forchetta

F= female  
M= male  
T= fork coupling

F= hembra  
M= macho  
T= toma de horquilla

Accessori di completamento nel capitolo:  
Accessories available in chapter:  
Accesorios de terminación en el capítulo:

**FITTINGS**



- Bypassa il liquido in eccesso e consente di mantenere costante la pressione di linea
- Con membrana di separazione per una migliore sensibilità di regolazione
- Dimensioni compatte
- Struttura in Nylon® rinforzato con fibra di vetro
- Particolari interni in Delrin® e acciaio Inox AISI 303
- Guarnizioni in Viton®

- By-passes the excess liquid and maintains constant line pressure
- Equipped with a separation diaphragm for enhanced control sensitivity
- Compact sizes
- Fibreglass reinforced Nylon body
- Internal parts in Delrin® and AISI 303 stainless steel
- Gaskets made of Viton®

- Deriva el líquido en exceso y permite mantener constante la presión de línea
- Con membrana de separación para mayor sensibilidad de regulación
- Tamaños compactos
- Estructura de Nylon reforzado con fibra de vidrio
- Piezas interiores de Delrin® y acero Inox AISI 303
- Juntas de Viton®

### Valvola di regolazione massima pressione elettrica a membrana, attacco a forchetta

### Electric diaphragm pressure relief control valve with fork coupling

### Válvula de regulación máxima presión eléctrica de membrana con conexión de horquilla



COD. CODE CÓD.	Pressure		sec.	12 Vdc 3 A	lt/1'	US GPM	Ø1	Ø2	Ø BY PASS
	bar	PSI							
<b>875 0651</b>	10	145	16	12 Vdc 3 A	200	53	T5 F	T5 F	T5 F
<b>875 0652</b>	20	290							

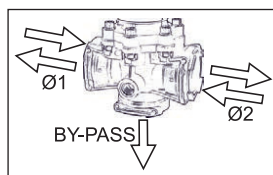

		A	B	C
A	B	mm 114	246	152
	C	inches 4,5"	9,7"	6,0"

### Valvola di regolazione massima pressione elettrica a membrana, attacco a forchetta

### Electric diaphragm pressure relief control valve with fork coupling

### Válvula de regulación máxima presión eléctrica de membrana con conexión de horquilla

**HI-FLOW**  
450 l/min



COD. CODE CÓD.	Pressure		sec.	12 Vdc 3 A	lt/1'	US GPM	Ø1	Ø2	Ø BY PASS
	bar	PSI							
<b>875 0660</b>	8	116	16	12 Vdc 3 A	450	120	T6 F	T6 F	T6 F
<b>875 06612</b>	12	174							

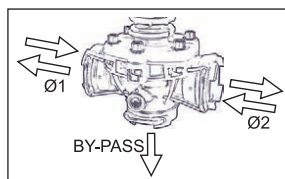

		A	B	C
A	B	mm 158	254	152
	C	inches 6,3"	10,0"	6,0"

Accessori di completamento nel capitolo:  
Accessories available in chapter:  
Accesorios de terminación en el capítulo:

**FITTINGS**

Cavi e spine DIN a 3 fili  
3-wires DIN cables and plugs  
Cables y tomas DIN a 3 hilos



COD. / CODE / CÓD.  
**ECS0033**

COD. / CODE / CÓD.  
**8650900.140 (1.3 m)**

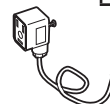

# FLUSSOMETRI FLOWMETERS CAUDALIMETROS



## Flussometro elettromagnetico ORION 2

- Attacco a forchetta maschio/femmina T5 per collegamento diretto ai gruppi di comando
- Assenza di organi meccanici in movimento
- Insensibilità alla densità ed alla viscosità del fluido
- Bassa sensibilità alle turbolenze
- Elevata precisione
- Ridotta manutenzione
- Errore tipico 0,5% del fondoscala
- Tensione di alimentazione 11÷15 Vdc
- Uscita ad impulsi 0-12 Vdc con frequenza proporzionale alla portata
- Consumo massimo 300 mA
- Emissione di segnale solo in presenza di fluido in movimento
- Parti a contatto con il fluido in polipropilene e acciaio Inox 316
- LED indicatore di funzionamento
- Connettore integrato nel corpo

## ORION 2 electromagnetic flow-meter

- T5 male/female fork connector for direct connection to control units
- No mechanical moving parts inside the pipe
- Performances independent from fluid density and viscosity
- Low sensitivity to turbulence
- High precision
- Low maintenance
- Typical error: 0,5% of full scale
- Power supply: 11 to 15 Vdc
- 0-12 Vdc pulse output with frequency proportional to rate
- Max consumption: 300 mA
- Output only by flowing fluid
- Parts in contact with fluid made of polypropylene and Stainless Steel 316
- Operating status LED
- Connector integrated in the body

## Caudalímetro electromagnético ORION 2

- Empalme con acople de horquilla macho / hembra T5 para conexión directa a los grupos de mando
- Sin elementos mecánicos en movimiento
- Funcionamiento independiente de la densidad y de la viscosidad del fluido
- Baja sensibilidad a las turbulencias
- Elevada precisión
- Error típico 0,5% del fondo escala
- Tensión de alimentación 11÷15 Vcc
- Salida a impulsos 0-12 Vcc con frecuencia proporcional al caudal
- Consumo máximo 300 mA
- Transmisión de la señal solo en presencia de fluido en movimiento
- Componentes en contacto con el fluido en polipropileno y acero Inox 316
- LED indicador de funcionamiento
- Conector integrado al cuerpo



COD. CODE CÓD.	Fork Coupling		Pressure		Attacco Connection Toma	Passaggi interni Internal passages Pasos internos	Impulsi Pulses Impulse	
	lt/1'	US GPM	bar	PSI			mm	pls/l
<b>46211A3A5B5</b>	5÷100	1.3÷26	20	290	T5 F/M	14	600	2271
<b>46211A4A5B5</b>	10÷200	2.6÷53	20	290	T5 F/M	18,5	300	1135



**Cavo di alimentazione  
Feeding cable  
Cable de alimentación**

COD. CODE CÓD.	Poli Poles Polos	mt	per for para
<b>4621AA10000.100</b>	3	3	ORION2/WOLF

## Flussometro a palette WOLF

- Alta precisione e ottimo rapporto prezzo/prestazioni
- Attacco a forchetta maschio/femmina T5 per collegamento diretto ai gruppi di comando
- LED indicatore di funzionamento
- Perno delle palette in zaffiro per ridurre al minimo gli attriti durante la rotazione e aumentare al massimo sensibilità e precisione
- Gruppo palette con sistema "TWIST" per la pulizia o la sostituzione senza bisogno di attrezzi
- Sensore elettronico completamente sigillato e a tenuta stagna
- Errore tipico 1% del fondoscala
- Tensione di alimentazione 4÷26 Vdc
- Consumo massimo 25 mA
- Uscita ad impulsi 0-12 Vdc con frequenza proporzionale alla portata
- Parti a contatto con il fluido in Nylon® rinforzato con fibra di vetro e Delrin®

## WOLF paddle flow-meter

- Hi-precision and good price/performance ratio
- T5 male/female fork connector for direct connection to control units
- Operating status LED
- Sapphire paddle pin to minimize rotational friction and maximize sensitivity and accuracy
- Paddle assembly equipped with "TWIST" system for either cleaning or replacing operations without the need of any tools
- Fully sealed and watertight electronic sensor
- Typical error: 1% of the full scale
- Power supply: 4 to 26 Vdc
- Max. consumption: 25 mA
- 0-12 Vdc pulse output with frequency proportional to rate
- Parts in contact with the fluid are made of fiberglass and Delrin® reinforced Nylon

## Caudalímetro de paletas WOLF

- Alta precisión y excelente relación precio/prestaciones
- Empalme con acople de horquilla macho / hembra T5 para conexión directa a los grupos de mando
- LED indicador de funcionamiento
- Perno de las paletas de zafiro para reducir al mínimo los rozos durante la rotación y aumentar al máximo la sensibilidad y la precisión
- Grupo paleta con sistema "TWIST" para la limpieza o la sustitución sin necesidad de herramientas
- Sensor electrónico completamente sellado y hermético
- Error típico 1% del fondo escala
- Tensión de alimentación 4÷26 Vcc
- Consumo máximo 25 mA
- Salida a impulsos 0-12 Vcc con frecuencia proporcional al caudal
- Piezas en contacto con el líquido de Nylon reforzado con fibra de vidrio y Delrin®



COD. CODE CÓD.	Fork Coupling		Attacco Connection Toma	Ø Equiv.	Pressure	
	lt/1'	US GPM			P max (bar)	P max (PSI)
<b>462 6315</b>	5-100	1.3-26	T5 F/M	1" 1/4	20	290
<b>462 6415</b>	10-200	2.6-53	T5 F/M	1" 1/4	20	290



**Cavo di alimentazione  
Feeding cable  
Cable de alimentación**

COD. CODE CÓD.	Poli Poles Polos	mt	per for para
<b>4621AA10000.100</b>	3	3	ORION2/WOLF

# 326 - 322

FILTRI IN LINEA  
LINE FILTERS  
FILTROS EN LINEA

C113  
FORK  
COUPLING

## Filtri in linea serie 326

- Attacco a forchetta T5 maschio/femmina
- Cartuccia Ø 58x210mm
- Corpo in polipropilene rinforzato
- Guarnizioni in EPDM (a richiesta in Viton®)
- Capacità filtrante 200÷280 l/min
- Versione autopulente con valvola di scarico



## Line filters series 326

- T5 male/female fork coupling
- Cartridge Ø 58x210mm
- Reinforced Polypropylene body
- EPDM gaskets (Viton® optional)
- Filtering capacity 200÷280 l/min
- Self-cleaning version with drain valve

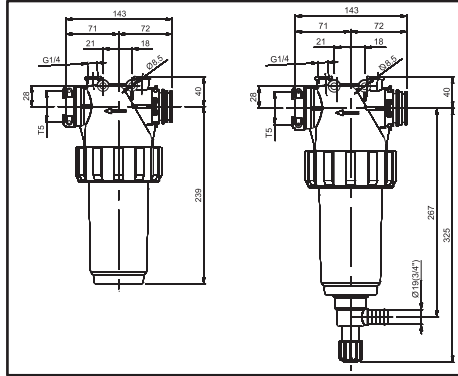

## Filtros en línea serie 326

- Toma de horquilla T5 macho / hembra
- Cartucho Ø 58x210mm
- Cuerpo de polipropileno reforzado
- Juntas en EPDM (bajo demanda, en Viton®)
- Capacidad filtrante 200÷280 l/min
- Versión autolimpiante con válvula de descarga





**T5**  
fork  
coupling

**ISO**  
colour  
coding

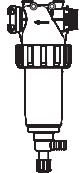

Ricambio  
Spare part  
Repuesto

COD. / CODE / CÓD.	Tipo / Type / Tipo
<b>3262003.030</b>	Inox 50 mesh
<b>32620035.030</b>	Inox 80 mesh

		 20 bar max 290 PSI max		
		 210 l/min @ 0,4 bar 55 US GPM @ 5 PSI		
STANDARD STANDARD ESTÁNDAR	AUTOPULENTE SELF-CLEANING AUTOLIMPIANTE	TIPO DI RETE SCREEN TYPE TIPO DE RED	AREA EFFETTIVA EFFECTIVE AREA ÁREA EFECTIVA	
COD. / CODE / CÓD.	COD. / CODE / CÓD.		cm <sup>2</sup>	sq. inches
<b>326 20M3</b>	<b>326 21M3</b>	Inox 50 mesh	106	16.4
<b>326 20M35</b>	<b>326 21M35</b>	Inox 80 mesh	97	15

## Filtri in linea serie 322

- Attacco a forchetta T5 maschio/femmina
- Cartuccia Ø 38x125mm
- Corpo in polipropilene rinforzato
- Guarnizioni in EPDM (a richiesta in Viton®)
- Capacità filtrante 150÷160 l/min
- Versione autopulente con valvola di scarico



## Line filters series 322

- T5 male/female fork coupling
- Cartridge Ø 38x125mm
- Reinforced Polypropylene body
- EPDM gaskets (Viton® optional)
- Filtering capacity 150÷160 l/min
- Self-cleaning version with drain valve

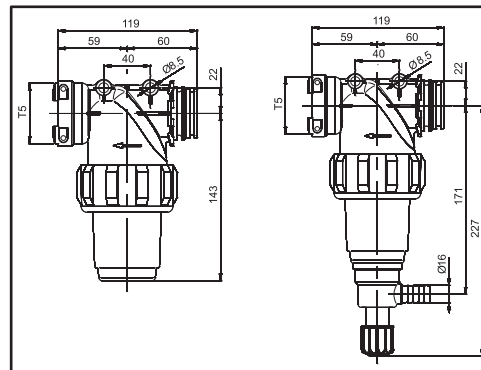



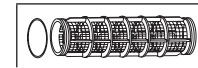

**T5**  
fork  
coupling

**ISO**  
colour  
coding



Ricambio  
Spare part  
Repuesto

COD. / CODE / CÓD.	Tipo / Type / Tipo
<b>3232003.030</b>	Inox 50 mesh
<b>32320035.030</b>	Inox 80 mesh

		 20 bar max 290 PSI max		
		 150 l/min @ 0,4 bar 40 US GPM @ 5 PSI		
STANDARD STANDARD ESTÁNDAR	AUTOPULENTE SELF-CLEANING AUTOLIMPIANTE	TIPO DI RETE SCREEN TYPE TIPO DE RED	AREA EFFETTIVA EFFECTIVE AREA ÁREA EFECTIVA	
COD. / CODE / CÓD.	COD. / CODE / CÓD.		cm <sup>2</sup>	sq. inches
<b>322 20M3</b>	<b>322 21M3</b>	Inox 50 mesh	38	5.9
<b>322 20M35</b>	<b>322 21M35</b>	Inox 80 mesh	34	5.3

# VALVOLE SEZIONE DI BARRA CON ATTACCO A FORCHETTA BOOM SECTION VALVES WITH FORK COUPLING VÁLVULAS SECCION DE BARRA CON CONEXIÓN DE HORQUILLA

# 863T

## Valvola sezione di barra singola ad azionamento elettrico con attacco a forchetta

- Struttura in Nylon® rinforzato con fibra di vetro
- Particolari interni in Delrin® e acciaio Inox AISI 303
- Guarnizioni in Viton®
- Fusibile interno resettabile (togliendo l'alimentazione per 20 secondi)
- Idonea al collegamento con i ritorni calibrati (solo cod. 863T011)

## Electric boom section valve with fork connection

- Fibreglass-reinforced Nylon body
- Internal parts in Delrin® and AISI 303 stainless steel
- Gaskets made of Viton®
- Internal resettable fuse (disconnecting power for 20 seconds)
- Suitable for connection to metered-by-pass (only code 863T011)

## Válvula sección de barra de accionamiento eléctrico con empalme de horquilla

- Estructura de Nylon reforzado con fibra de vidrio
- Piezas interiores de Delrin® y acero Inox AISI 303
- Juntas de Viton®
- Fusible interior rearmable (parando l'alimentacion para 20 sec.)
- Idonea para la conexión con retornos calibrados (solo cod. 863T011)



COD. CODE Cód.	TIPO TYPE TIPO	Pressure		Time	Voltage	Flow @ 0,5 bar		Ø OUT
		bar	PSI			lt/1'	US GPM	
863T 001	ON/OFF	20	290	0,6	12 Vdc	50	13	*
863T 011	BY-PASS				0,5 A			

A B C	863T001			863T011			
	A	B	C	A	B	C	
	mm	81	195	99	81	218	99
	inches	3.2	7.7	3.9	3.2	8.6	3.9

## Gruppo a 3 sezioni di barra ad azionamento elettrico, con attacco a forchetta



## 3 way- electric control unit with fork couplings



## Grupo de 3 secciones de barra de accionamiento electrico, con empalme de horquilla



COD. CODE Cód.	TIPO TYPE TIPO	Pressure		Time	Voltage	Flow @ 0,5 bar		Ø OUT
		bar	PSI			lt/1'	US GPM	
863T 003	ON/OFF	20	290	0,6	12 Vdc	50	13	*
863T 013	BY-PASS				0,5 A			

A B C	863T003			863T013			
	A	B	C	A	B	C	
	mm	195	195	99	195	218	99
	inches	7.7	7.7	3.9	7.7	8.6	3.9

\*Raccordo di uscita con attacco a forchetta T3 da ordinare separatamente.  
Output fitting with T3 fork coupling to be ordered separately.  
Empalme de salida con toma de horquilla T3 para pedir por separado.

O'ring da ordinare separatamente.  
O'ring to be ordered separately.  
O'ring a pedir por separado.



COD.	T	Ø (mm)	L (mm)	L	O'ring	
					COD. (EPDM)	COD. (Viton®)
109 1310	T3	10	37	25	G11058	G11058V
109 1313		13	39	25		
109 1316		16	39	25		
109 1320		20	44	25		
109 1325		25	44	25		
109 1330		30	48	25		

### ! IMPORTANTE! - !IMPORTANT! - !¡IMPORTANTE!

Raccordi di completamento con attacco a forchetta da ordinare **SEPARATAMENTE** dal capitolo "FITTINGS"  
End fork fittings must be ordered **SEPARATELY** in the chapter "FITTINGS"  
Empalmes de terminación con toma de horquilla deben pedirse **POR SEPARADO** a la sección "FITTINGS"

### Valvola sezione di barra ad azionamento elettrico con collegamento A-net e attacco a forchetta T5

La nuova valvola serie 863T con collegamento A-net può essere collegata al computer per sistemi ausiliari Syncro insieme alle valvole a sfera 853, per eseguire quelle funzioni in cui non è richiesto un posizionamento intermedio o elevate portate (es. lavaggio cisterna, mixer, ecc.), riducendo il costo e gli ingombri del sistema.

La stessa valvola può essere montata in sistemi misti con le valvole Seletron, in macchine da diserbo dove è richiesta un'elevata parzializzazione della barra solo sulle estremità (Seletron), rispetto alla parte centrale (863T).

- Porta di collegamento A-net, per comando e diagnostica valvola.
- Attacco a forchetta T5, per raccordo di scarico T3.
- Elettronica integrata di controllo e gestione motore.
- Fusibile interno resettabile (togliendo l'alimentazione per 20 secondi)
- Led di segnalazione stato valvola.
- Struttura in Nylon® rinforzato con fibra di vetro.
- Particolari interni in Delrin® e acciaio Inox AISI 303.
- Guarnizioni in Viton®.
- Versione per il collegamento con i ritorni calibrati (cod. 863TA11).

### Boom section valve with electric activation with A-net connection and T5 fork coupling

The new 863T series valve with A-net connection can be connected to the computer for Syncro auxiliary systems together with 853 ball valves for those functions that do not require an intermediate positioning or a high flowrate (e.g. tank flushing, mixer etc.), reducing at the same time the system cost and dimensions.

This valve can be fitted in mixed systems with Seletron valves, on crop sprayers where a high adjustment is required at boom ends (Seletron) and not in the central section (863T).

- A-net connection port for valve control and diagnostics.
- Integrated engine control and management electronics.
- Internal resettable fuse (disconnecting power for 20 seconds)
- Valve status LED.
- Structure in fiber glass reinforced Nylon.
- Internal parts in Delrin® and AISI 303 stainless steel.
- Seals in Viton®.
- Version for connection to the metered by-pass (code 863TA11).

### Válvula sección de barra con accionamiento eléctrico con conexión A-net y empalme de horquilla T5

La nueva válvula serie 863T con conexión A-net se puede conectar al ordenador para sistemas auxiliares Syncro junto a las válvulas de bola 853 para realizar las funciones donde no se requieren posicionamiento intermedio o elevados caudales (ej. lavado cisterna, mixer, etc.), reduciendo el costo y los espacios del sistema.

La misma válvula puede ser montada en sistemas mixtos con las válvulas Seletron, en máquinas pulverizadoras donde se requiere una elevada parzialización de la barra sólo en los extremos (Seletron), respecto a la parte central (863T).

- Conexión A-net, para mando y diagnosis válvula.
- Electrónica integrada de control y gestión motor.
- Fusible interior rearmable (parando l'alimentacion para 20 sec.)
- Led de señalización estado válvula.
- Estructura de Nylon reforzada con fibra de vidrio.
- Componentes internos de Delrin® y acero Inoxidable AISI 303.
- Juntas de Viton®.
- Versión para la conexión con los retornos calibrados (cód. 863TA11).



863TA01



863TA11

COD. CODE Cód.	TIPO TYPE TIPO	bar		sec.	12 Vdc 0,5 A	@ 0,5 bar lt/1'	US GPM	Ø OUT
		bar	PSI	sec.				
863T A01	ON/OFF	20	290	0,6	12 Vdc 0,5 A	50	13	*
863T A11	BY-PASS							



A B C	863TA01			863TA11			
	A	B	C	A	B	C	
	mm	mm	mm	mm	mm	mm	
	81	195	109	81	218	109	
	inches	3.2	7.7	4.3	3.2	8.6	4.3

#### ! IMPORTANTE! - IMPORTANT! - ¡IMPORTANTE!

Raccordi di completamento con attacco a forchetta da ordinare **SEPARATEMENTE** dal capitolo "FITTINGS"

End fork fittings must be ordered **SEPARATELY** in the chapter "FITTINGS"

Empalmes de terminación con toma de horquilla deben pedirse **POR SEPARADO** a la sección "FITTINGS"

\*Raccordo di uscita con attacco a forchetta T3 da ordinare separatamente.  
Output fitting with T3 fork coupling to be ordered separately.  
Empalme de salida con toma de horquilla T3 para pedir por separado.



O'ring da ordinare separatamente.  
O'ring to be ordered separately.  
O'ring a pedir por separado.

COD.	T	Ø (mm)	L (mm)	COD. (EPDM)	COD. (Viton®)
109 1310		10	37	G11058	G11058V
109 1313		13	39		
109 1316	T3	16	39		
109 1320		20	44		
109 1325		25	44		
109 1330		30	48		

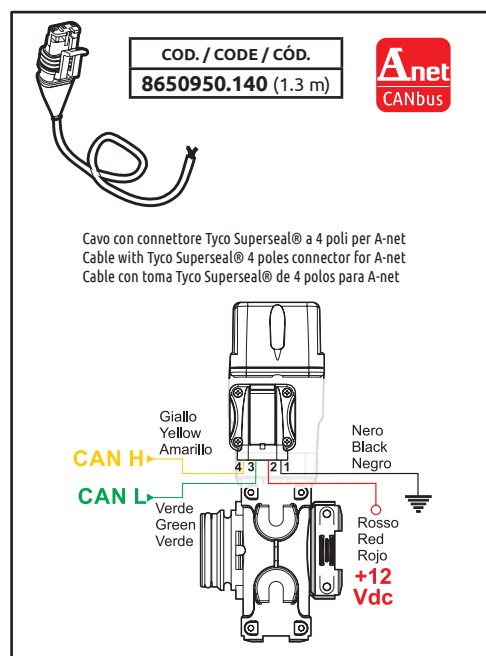

# ACCESSORI PER VALVOLE MODULARI ACCESSORIES FOR MODULAR VALVES ACCESORIOS PARA VÁLVULAS MODULARES

# 863T

## Collettori con valvola di scarico pressione

- Consentono di azzerare la pressione residua del liquido che rimane intrappolato tra le valvole di sezione e valvola antigoccia, riducendo il gocciolamento.
- Azionamento a comando indotto dal motoriduttore della valvola
- Montaggio modulare con attacco a forchetta per facilitare l'installazione e l'ispezione
- Applicabili a tutti i gruppi ARAG serie 863T.

## Manifold with bleeder valve

- Used to bleed off the residual pressure of the liquid that remains trapped between the section valves and check valve, thus reducing dripping.
- Induced control drive via valve geared motor
- Modular assembly with fork coupling for easier installation and inspection
- Can be fitted and retrofitted to all electric ARAG units series 863T.

## Colectores con válvula de descarga presión

- Permiten poner a cero la presión residual del líquido que permanece atrapado entre las válvulas de sección y la válvula antigoteo, reduciendo el goteo.
- Accionamiento con mando inducido por el motorreductor de la válvula
- Montaje modular con toma de horquilla para facilitar la instalación y la inspección
- Pueden aplicarse en todos los grupos eléctricos ARAG serie 863T.

COD. CODE CÓD.	Per valvole For valves Para válvulas
863T 2000.300	863T



**T5**  
fork  
coupling  
Maschio  
Male  
Macho



**T5**  
fork  
coupling  
Femmina  
Female  
Hembra

bar  
20  
290  
PSI

**T3**  
fork  
coupling  
Maschio  
Male  
Macho

Raccordi di completamento con attacco a forchetta nel capitolo:  
End fittings with fork coupling in chapter:  
Empalmes de terminación con toma de horquilla en el capítulo:

**FITTINGS**

Forchette e O-ring sono già compresi nel collettore e non devono essere ordinati.

Forks and O-rings included in the manifold and therefore should not be ordered separately.

Horquillas y O-ring ya incluidos en el colector y no se deben pedir.

### Possibilità di utilizzo:

1. Azzeramento pressione residua nelle tubazioni delle sezioni di barra per ridurre al minimo gli sgocciolamenti.
1. Residual pressure zeroing into boom section tubes to minimize dripping.
1. Puesta en cero presión residual en los tubos de la sección de barra para reducir al mínimo el goteo.

### Use examples:

2. Circolazione continua del liquido nelle sezioni di barra durante la fase di by-pass, per ridurre la sedimentazione dei prodotti chimici.
2. Steady fluid flowing into boom sections during by-pass to reduce chemical settling.
2. Circulación continua del líquido en las secciones de barra durante la fase de by-pass, para reducir el sedimento de los productos químicos.

3. Lavaggio delle tubazioni delle sezioni di barra a fine trattamento con consumo ridotto di acqua pulita.
3. Boom section tube cleaning at the end of the spraying session with reduced fresh water consumption.
3. Lavado de los tubos de las secciones de barra al finalizar el tratamiento con consumo reducido de agua limpia.

### Posibilidad de uso:

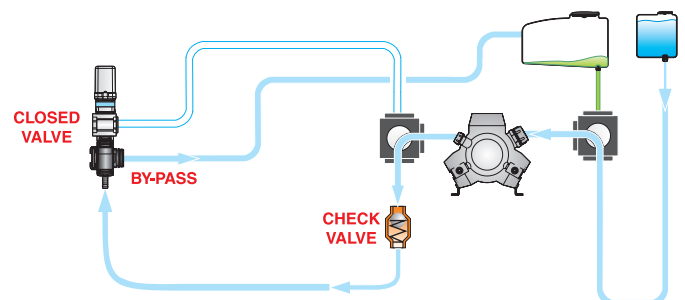
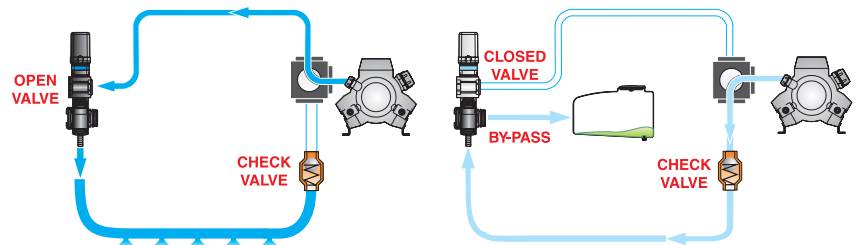
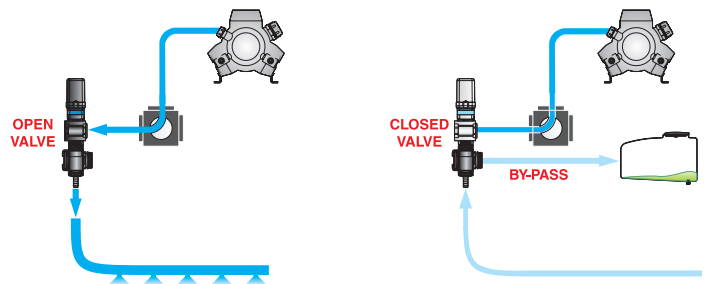

# 863T

## GRUPPI VALVOLE VALVE UNITS GRUPOS VÁLVULAS

C113  
FORK  
COUPLING

Gruppo elettrovalvole serie 863T con ritorni calibrati e attacco a forchetta T5  
Composto dalle valvole 863T011 e 863T013.

Series 863T electrovalve set with metered by-pass and T5 fork connection  
Consisting of 863T011 and 863T013 valves.

Grupo electroválvulas serie 863T con retornos calibrados y empalme con acople de horquilla T5  
Compuesto por las válvulas 863T011 y 863T013.



Ingresso Inlet  
Entrada

T5  
fork  
coupling



COD. CODE CÓD.	Vie Ways Vías		
		bar	PSI
863T 0120	2	20	290
863T 0130	3		
863T 0140	4		
863T 0150	5		
863T 0160	6		
863T 0170	7		

### BY-PASS

T4  
fork  
coupling

Accessori di completamento nel capitolo:  
Accessories available in chapter:  
Accesorios de terminación en el capítulo:

**FITTINGS**

Gruppo elettrovalvole serie 863T ON/OFF con attacco a forchetta T5  
Composto dalle valvole 863T001 e 863T003.

Series 863T ON-OFF electrovalve set with T5 fork connection  
Consisting of 863T001 and 863T003 valves.

Grupo electroválvulas serie 863T ON/OFF con empalme con acople de horquilla T5  
Compuesto por las válvulas 863T001 y 863T003.



Ingresso Inlet  
Entrada

T5  
fork  
coupling



COD. CODE CÓD.	Vie Ways Vías		
		bar	PSI
863T 0020	2	20	290
863T 0030	3		
863T 0040	4		
863T 0050	5		
863T 0060	6		
863T 0070	7		

\*Raccordo di uscita con attacco a forchetta T3 da ordinare separatamente.  
Output fitting with T3 fork coupling to be ordered separately.  
Empalme de salida con toma de horquilla T3 para pedir por separado.

O'ring da ordinare separatamente.  
O'ring to be ordered separately.  
O'ring a pedir por separado.



COD.	T	Ø (mm)	L (mm)		COD. (EPDM)	COD. (Viton®)
109 1310	T3	10	37	25	G11058	G11058V
109 1313		13	39	25		
109 1316		16	39	25		
109 1320		20	44	25		
109 1325		25	44	25		
109 1330		30	48	25		

### ! IMPORTANTE! - IMPORTANT! - ¡IMPORTANTE!

Raccordi di completamento con attacco a forchetta da ordinare **SEPARATEMENTE** dal capitolo "FITTINGS"

End fork fittings must be ordered **SEPARATELY** in the chapter "FITTINGS"

Empalmes de terminación con toma de horquilla deben pedirse **POR SEPARADO** a la sección "FITTINGS"

VALVOLE SEZIONE DI BARRA CON ATTACCO A FORCHETTA  
BOOM SECTION VALVES WITH FORK COUPLING  
VÁLVULAS SECCION DE BARRA CON CONEXIÓN DE HORQUILLA

863T

Gruppi elettrici con ritorni calibrati

Raccordo maschio T5 con portamanometro G1/4F  
T5 Male fitting with pressure gauge G1/4F  
Racor macho T5 con portamanómetro G1/4F

COD.	O'ring	
	COD. (EPDM)	COD. (Viton®)
219 350	G11063	G11063V

Electric control units with metered by-pass

**T5**  
fork coupling

Raccordi di completamento con attacco a forchetta T5 e O'ring nel capitolo:  
End fittings with T5 fork coupling and O-ring in chapter:  
Empalmes de terminación con toma de horquilla T5 y O'ring en el capítulo:

**FITTINGS**

Grupos electricos con retornos calibrados

Corpo a 3 vie con attacco a forchetta T5 e uscita T3  
3-way body with T5 fork and T3 output couplings  
Cuerpo de 3 vías con toma de horquilla T5 y salida T3

COD.
863T013

Corpo singolo con attacco a forchetta T5 e uscita T3  
Single body with T5 fork and T3 output couplings  
Cuerpo individual con toma de horquilla T5 y salida T3

COD.
863T011

Raccordo femmina T5 con portamanometro G1/4F  
T5 Female fitting for pressure gauge G1/4F  
Racor hembra T5 con portamanómetro G1/4F

COD.
219 250

**T4**  
fork coupling

Ritorni calibrati con attacco a forchetta (compresa)  
Metered by-pass with fork coupling (included)  
Retornos calibrados con toma de horquilla (incluida)

Descr.	COD.
Ritorno calibrato per valvole 863T Metered by-pass for valve 863T Retorno calibrado para válvulas 863T	4632010.810

Tappo maschio T4 per chiusura ritorno calibrato  
T4 Male plug for metered by-pass closing  
Tapón macho T4 para cierre del retorno calibrado

COD.	O'ring	
	COD. (EPDM)	COD. (Viton®)
219 140	G11054	G11054V

**T3**  
fork coupling

Raccordi di completamento con attacco a forchetta T3 e O'ring nel capitolo:  
End fittings with T3 fork coupling and O-ring in chapter:  
Empalmes de terminación con toma de horquilla T3 y O'ring en el capítulo:

**FITTINGS**

**T5**  
fork coupling

Raccordi di completamento con attacco a forchetta T5 e O'ring nel capitolo:  
End fittings with T5 fork coupling and O-ring in chapter:  
Empalmes de terminación con toma de horquilla T5 y O'ring en el capítulo:

**FITTINGS**

Forchetta Fork  
Horquilla

COD.
010 005

**! IMPORTANTE! - IMPORTANT! - ¡IMPORTANTE!**  
Raccordi di completamento con attacco a forchetta da ordinare **SEPARATAMENTE** dal capitolo "FITTINGS"  
End fork fittings must be ordered **SEPARATELY** in the chapter "FITTINGS"  
Empalmes de terminación con toma de horquilla deben pedirse **POR SEPARADO** a la sección "FITTINGS"

Cavi e spine DIN a 3 fili  
3-wires DIN cables and plugs  
Cables y tomas DIN a 3 hilos

COD. / CODE / CÓD.
ECS0033

COD. / CODE / CÓD.
8650900.140 (1.3 m)



### Gruppi elettrici on/off

### On/off electric control units

### Grupos electricos on/off

Raccordo maschio T5 con portamanometro G1/4F  
T5 Male fitting with pressure gauge G1/4F  
Racor macho T5 con portamanómetro G1/4F

COD.	O'ring	
	COD. (EPDM)	COD. (Viton®)
219 350	G11063	G11063V

Corpo singolo con attacco a forchetta T5 e uscita T3  
Single body with T5 fork and T3 output couplings  
Cuerpo individual con toma de horquilla T5 y salida T3

COD.
863T001

Corpo a 3 vie con attacco a forchetta T5 e uscita T3  
3-way body with T5 fork and T3 output couplings  
Cuerpo de 3 vías con toma de horquilla T5 y salida T3

COD.
863T003



Raccordo femmina T5 con portamanometro G1/4F  
T5 Female fitting for pressure gauge G1/4F  
Racor hembra T5 con portamanómetro G1/4F

COD.
219 250



**T5**  
fork coupling

Raccordi di completamento con attacco a forchetta T5 e O'ring nel capitolo:  
End fittings with T5 fork coupling and O-ring in chapter:  
Empalmes de terminación con toma de horquilla T5 y O'ring en el capítulo:

**FITTINGS**

**! IMPORTANTE! - IMPORTANT! - ¡IMPORTANTE!**

Raccordi di completamento con attacco a forchetta da ordinare **SEPARATEMENTE** dal capitolo "FITTINGS"  
End fork fittings must be ordered **SEPARATELY** in the chapter "FITTINGS"  
Empalmes de terminación con toma de horquilla deben pedirse **POR SEPARADO** a la sección "FITTINGS"

**T3**  
fork coupling

Raccordi di completamento con attacco a forchetta T3 e O'ring nel capitolo:  
End fittings with T3 fork coupling and O-ring in chapter:  
Empalmes de terminación con toma de horquilla T3 y O'ring en el capítulo:

**FITTINGS**

Forchetta  
Fork  
Horquilla

COD.
010 005

**T5**  
fork coupling

Raccordi di completamento con attacco a forchetta T5 e O'ring nel capitolo:  
End fittings with T5 fork coupling and O-ring in chapter:  
Empalmes de terminación con toma de horquilla T5 y O'ring en el capítulo:

**FITTINGS**

Cavi e spine DIN  
DIN cables and plugs  
Cables y tomas DIN

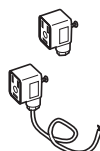

COD. / CODE / CÓD.
ECS0033

COD. / CODE / CÓD.
8650900.140 (1.3 mt)

# VALVOLE SEZIONE DI BARRA CON ATTACCO A FORCHETTA BOOM SECTION VALVES WITH FORK COUPLING VÁLVULAS SECCION DE BARRA CON CONEXIÓN DE HORQUILLA

862 **NEW**

## Valvola sezione di barra singola, a due vie ad azionamento elettrico

Le valvole serie 862 sono state progettate per l'inserimento diretto sulla barra e permettono di semplificare la costruzione di una barra da diserbo.

- Corpo disponibile con attacco a forchetta T3 e T3 + EASYFIT.
- Disponibile con attacchi in linea o a 90°.
- Connettore a tenuta stagna integrato nel corpo del motore.
- LED di segnalazione dello stato della valvola.
- Membrana di sfiato traspirante in PTFE.
- Struttura in Nylon® rinforzato con fibra di vetro
- Particolari interni in Delrin® e acciaio Inox AISI 303
- Guarnizioni in Viton®
- Fusibile interno resettabile (togliendo l'alimentazione per 20 secondi).

## Two-way electrically operated single boom section valve

862 series valves have been designed to be directly inserted onto the boom and allow to easily construct a crop spraying boom.

- Body available with T3 and T3 + EASYFIT fork coupling.
- Available with in-line or 90° couplings.
- Watertight connector integrated in the motor body.
- Valve status LED.
- Breather membrane in PTFE.
- Structure in fiber glass reinforced Nylon®.
- Internal parts in Delrin® and AISI 303 stainless steel.
- Seals in Viton®.
- Internal resettable fuse (disconnect the power supply for 20 seconds to reset).

## Válvula sección de barra individual, de dos vías de accionamiento eléctrico

Las válvulas serie 862 han sido diseñadas para la introducción directa en la barra y permiten simplificar la construcción de una barra de pulverización.

- Cuerpo disponible con conexión de horquilla T3 y T3 + EASYFIT.
- Disponible con conexiones en línea o a 90°.
- Conector de estanqueidad integrado en el cuerpo del motor.
- LED de señalización del estado de la válvula.
- Membrana de ventilación traspirante en PTFE
- Estructura de Nylon® reforzada con fibra de vidrio
- Componentes internos de Delrin® y acero inoxidable AISI 303
- Juntas de Viton®
- Fusible interno programable (interrumpir la alimentación por 20 segundos)

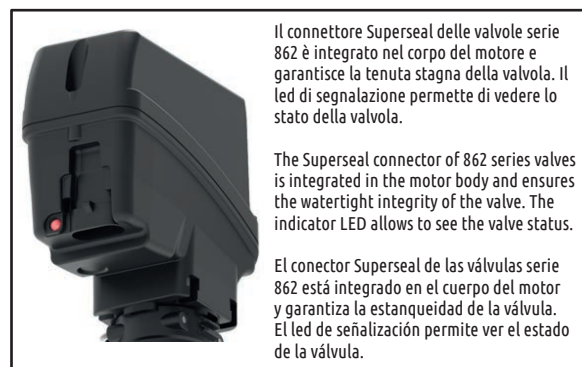

Il connettore Superseal delle valvole serie 862 è integrato nel corpo del motore e garantisce la tenuta stagna della valvola. Il led di segnalazione permette di vedere lo stato della valvola.

The Superseal connector of 862 series valves is integrated in the motor body and ensures the watertight integrity of the valve. The indicator LED allows to see the valve status.

El conector Superseal de las válvulas serie 862 está integrado en el cuerpo del motor y garantiza la estanqueidad de la válvula. El led de señalización permite ver el estado de la válvula.

## Valvola di regolazione PROPORZIONALE elettrica con attacco a forchetta

- Attacco T3/T3 femmina in linea.

## Electric PROPORTIONAL control valve with fork coupling

- In-line female T3/T3 coupling.

## Válvula de regulación PROPORCIONAL eléctrica con conexión de horquilla

- Conexión T3/T3 hembra en línea.



COD. CODE Cód.	bar	PSI	ON-OFF	12 Vdc 0.5 A	60 100	@ 1.5 bar @ 22 PSI 16 26
862A 3110	20	290	14 sec.	12 Vdc 0.5 A	60	16
862A 3120	20	290	14 sec.	12 Vdc 0.5 A	100	26
862A 3110S	20	290	7 sec.	12 Vdc 0.5 A	60	16
862A 3120S	20	290	7 sec.	12 Vdc 0.5 A	100	26

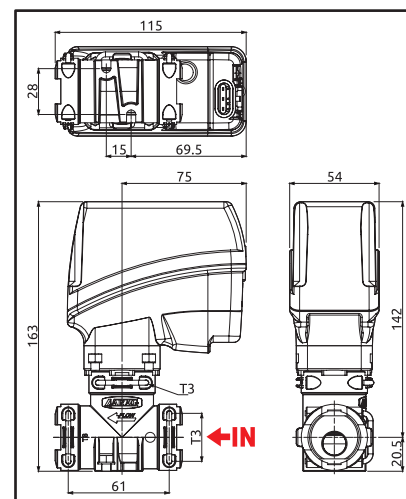
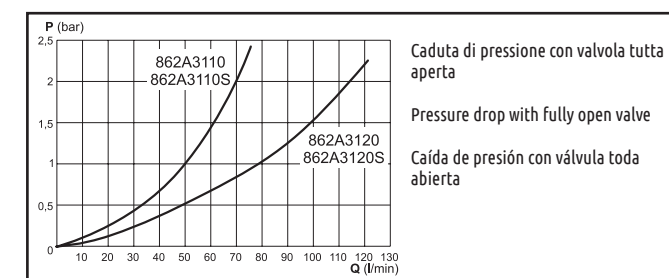

863T001			
	A	B	C
mm	54	163	115
inches	2.1	6.4	4.5



Valvola specifica per l'utilizzo con i computer BRAVO e DELTA: nuovo sistema di azionamento a diametro maggiorato, con trattamento antiusura per garantire una lunga durata.

Specific valve for use with BRAVO and DELTA computers: new larger-diameter drive system, with wear-proof coating for a longer life.

Válvula específica para el uso con los ordenadores BRAVO y DELTA: nuevo sistema de accionamiento de mayor diámetro, con tratamiento anti desgaste para garantizar una prolongada durabilidad.

**NEW****862**

# VALVOLE SEZIONE DI BARRA CON ATTACCO A FORCHETTA BOOM SECTION VALVES WITH FORK COUPLING VÁLVULAS SECCION DE BARRA CON CONEXIÓN DE HORQUILLA

C113  
FORK  
COUPLING

Valvola sezione di barra singola ad azionamento elettrico con attacco a forchetta

- Attacco T3/T3 femmina in linea.



COD. CODE CÓD.	TIPO TYPE TIPO	bar		sec.	@ 0,5 bar		
		bar	PSI	sec.	lt/1'	US GPM	
▶ <b>862A 1120</b>	ON/OFF	20	290	0,6	12 Vdc 0,5 A	50	13

862A 1120			
	A	B	C
mm	54	163	115
inches	2.1	6.4	4.5

Válvula sección de barra individual de accionamiento eléctrico con conexión de horquilla

- Conexión T3/T3 hembra en línea.

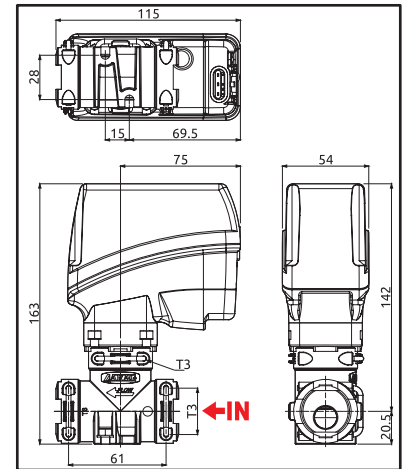

Valvola sezione di barra singola ad azionamento elettrico con attacco a forchetta

- Attacco T3F / EASYFIT 1/2 in linea.



COD. CODE CÓD.	TIPO TYPE TIPO	bar		sec.	@ 0,5 bar		
		bar	PSI	sec.	lt/1'	US GPM	
▶ <b>862A 1220</b>	ON/OFF	20	290	0,6	12 Vdc 0,5 A	50	13

862A 1220			
	A	B	C
mm	54	164	135
inches	2.1	6.5	5.3

Válvula sección de barra individual de accionamiento eléctrico con conexión de horquilla

- Conexión T3F/EASYFIT 1/2 en línea.

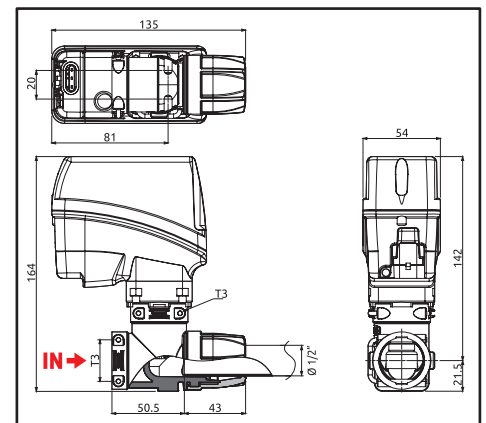

Valvola sezione di barra singola ad azionamento elettrico con attacco a forchetta

- Attacco T3/T3 femmina 90°.



COD. CODE CÓD.	TIPO TYPE TIPO	bar		sec.	@ 0,5 bar		
		bar	PSI	sec.	lt/1'	US GPM	
▶ <b>862A 2120</b>	ON/OFF	20	290	0,6	12 Vdc 0,5 A	50	13

862A 2120			
	A	B	C
mm	54	178	108
inches	2.1	7.0	4.2

Válvula sección de barra individual de accionamiento eléctrico con conexión de horquilla

- Conexión T3/T3 hembra 90°.

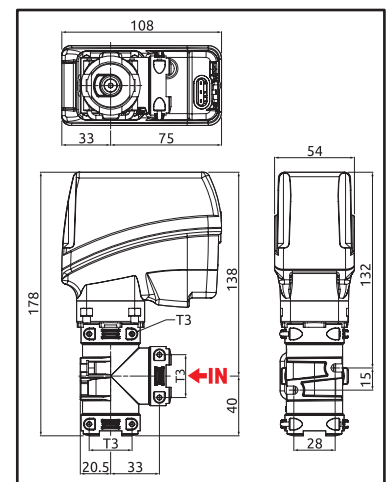

Cavo con connettore Tyco Superseal® a 3 poli  
Cable with Tyco Superseal® 3 poles connector  
Cable con toma Tyco Superseal® de 3 polos



COD. CODE CÓD.	mt
<b>4621AA10000.100</b>	3

# VALVOLE SEZIONE DI BARRA CON ATTACCO A FORCHETTA BOOM SECTION VALVES WITH FORK COUPLING VÁLVULAS SECCION DE BARRA CON CONEXIÓN DE HORQUILLA

# 463T

## Valvola sezione di barra singola ad azionamento manuale, con attacco a forchetta

- Struttura in Nylon® rinforzato con fibra di vetro
- Particolari interni in Delrin® e acciaio Inox AISI 303
- Guarnizioni in Viton®
- Idonea al collegamento con i ritorni calibrati (solo cod. 463T061)

## Manual single section valve with fork couplings

- Fibreglass-reinforced Nylon body
- Internal parts in Delrin® and AISI 303 stainless steel
- Gaskets made of Viton®
- Suitable for connection to metered by-pass (only code 463T061)

## Válvula de sección individual de accionamiento manual con empalme de horquilla

- Estructura de Nylon reforzado con fibra de vidrio
- Piezas interiores de Delrin® y acero Inox AISI 303
- Juntas de Viton®
- Idonea para la conexión con retornos calibrados (solo cod. 463T061)



COD. CODE CÔD.	TIPO TYPE TIPO	Pressure		Flow @ 0,5 bar		Ø OUT
		bar	PSI	lt/1'	US GPM	
463T 051	ON/OFF	20	290	50	13	*
463T 061	BY-PASS					

A B C	463T051			463T061			
	mm	A	B	C	A	B	C
	inches	81	127	92	81	156	92
		3.2	5	3.6	3.2	6.2	3.6

## Gruppo a 3 sezioni di barra ad azionamento manuale, con attacco a forchetta

## 3 way- manual control unit with fork couplings

## Grupo de 3 secciones de barra de acciona-miento manual, con empalme de horquilla



COD. CODE CÔD.	TIPO TYPE TIPO	Pressure		Flow @ 0,5 bar		Ø OUT
		bar	PSI	lt/1'	US GPM	
463T 053	ON/OFF	20	290	50	13	*
463T 063	BY-PASS					

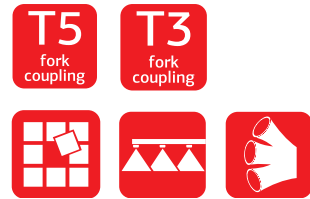

A B C	463T053			463T063			
	mm	A	B	C	A	B	C
	inches	195	127	92	195	156	92
		7.7	5	3.6	7.7	6.2	3.6

**\*Raccordo di uscita con attacco a forchetta T3 da ordinare separatamente.  
Output fitting with T3 fork coupling to be ordered separately.  
Empalme de salida con toma de horquilla T3 para pedir por separado.**

O'ring da ordinare separatamente.  
O'ring to be ordered separately.  
O'ring a pedir por separado.



COD.	T	Ø (mm)	L (mm)	Box	O'ring	
					COD. (EPDM)	COD. (Viton®)
109 1310	T3	10	37	25	G11058	G11058V
109 1313		13	39	25		
109 1316		16	39	25		
109 1320		20	44	25		
109 1325		25	44	25		
109 1330		30	48	25		

### ! IMPORTANTE! - IMPORTANT! - ¡IMPORTANTE!

Raccordi di completamento con attacco a forchetta da ordinare **SEPARATAMENTE** dal capitolo "FITTINGS"

End fork fittings must be ordered **SEPARATELY** in the chapter "FITTINGS"

Empalmes de terminación con toma de horquilla deben pedirse **POR SEPARADO** a la sección "FITTINGS"

# 463T

## GRUPPI VALVOLE MANUALI MANUAL VALVE UNITS GRUPOS VÁLVULAS MANUALES

Gruppo valvole manuali serie 463T  
componibili con attacco a forchetta T5 e  
ritorni calibrati.

Composto dalle valvole 463T061 e 463T063.

Series 463T modular manual valve unit  
with T5 fork coupling and metered by-  
pass

Consisting of 463T061 and 463T063 valves.

Grupo válvulas manuales serie 463T  
componibles con empalme de horquilla  
T5 y retornos calibrados.

Compuesto por válvulas 463T061 y 463T063.



Ingresso  
Inlet  
Entrada



COD. CODE CÓD.	Vie Ways Vias	Ingresso Inlet Entrada	
		bar	PSI
463T 0620	2	20	290
463T 0630	3		
463T 0640	4		
463T 0650	5		
463T 0660	6		
463T 0670	7		

Gruppo valvole manuali serie 463T ON/OFF  
componibili con attacco a forchetta T5.

Composto dalle valvole 463T051 e 463T053.

Series 463T ON/OFF modular manual  
valve unit with T5 fork coupling.

Consisting of 463T051 and 463T053 valves.

Grupo válvulas manuales serie 463T  
ON/OFF componibles con empalme de  
horquilla T5.

Compuesto por válvulas 463T051 y 463T053.



Ingresso  
Inlet  
Entrada



COD. CODE CÓD.	Vie Ways Vias	Ingresso Inlet Entrada	
		bar	PSI
463T 0520	2	20	290
463T 0530	3		
463T 0540	4		
463T 0550	5		
463T 0560	6		
463T 0570	7		

\*Raccordo di uscita con attacco a forchetta T3 da ordinare separatamente.

Output fitting with T3 fork coupling to be ordered separately.

Empalme de salida con toma de horquilla T3 para pedir por separado.

O'ring da ordinare  
separatamente.  
O'ring to be ordered  
separately.  
O'ring a pedir por separado.



COD.	T	Ø (mm)	L (mm)	L	O'ring	
					COD. (EPDM)	COD. (Viton®)
109 1310	T3	10	37	25	G11058	G11058V
109 1313		13	39	25		
109 1316		16	39	25		
109 1320		20	44	25		
109 1325		25	44	25		
109 1330		30	48	25		

**IMPORTANTE! - IMPORTANT! - ¡IMPORTANTE!**

Raccordi di completamento con attacco a forchetta da  
ordinare **SEPARATAMENTE** dal capitolo "FITTINGS"

End fork fittings must be ordered **SEPARATELY** in the  
chapter "FITTINGS"

Empalmes de terminación con toma de horquilla deben  
pedirse **POR SEPARADO** a la sección "FITTINGS"

# VALVOLE SEZIONE DI BARRA CON ATTACCO A FORCHETTA BOOM SECTION VALVES WITH FORK COUPLING VÁLVULAS SECCION DE BARRA CON CONEXIÓN DE HORQUILLA

# 463T

Gruppi manuali con ritorni calibrati

Manual units with metered by-pass

Grupos manuales con retornos calibrados

Raccordo maschio T5 con portamanometro G1/4F  
T5 Male fitting with pressure gauge G1/4F  
Racor macho T5 con portamanómetro G1/4F

Corpo singolo con attacco a forchetta T5 e uscita T3  
Single body with T5 fork and T3 output couplings  
Cuerpo individual con toma de horquilla T5 y salida T3

Corpo a 3 vie con attacco a forchetta T5 e uscita T3  
3-way body with T5 fork and T3 output couplings  
Cuerpo de 3 vías con toma de horquilla T5 y salida T3

Raccordo femmina T5 con portamanometro G1/4F  
T5 Female fitting for pressure gauge G1/4F  
Racor hembra T5 con portamanómetro G1/4F

COD.	O'ring	
	COD. (EPDM)	COD. (Viton®)
219 350	G11063	G11063V

COD.
463T 061

COD.
463T 063

COD.
219 250

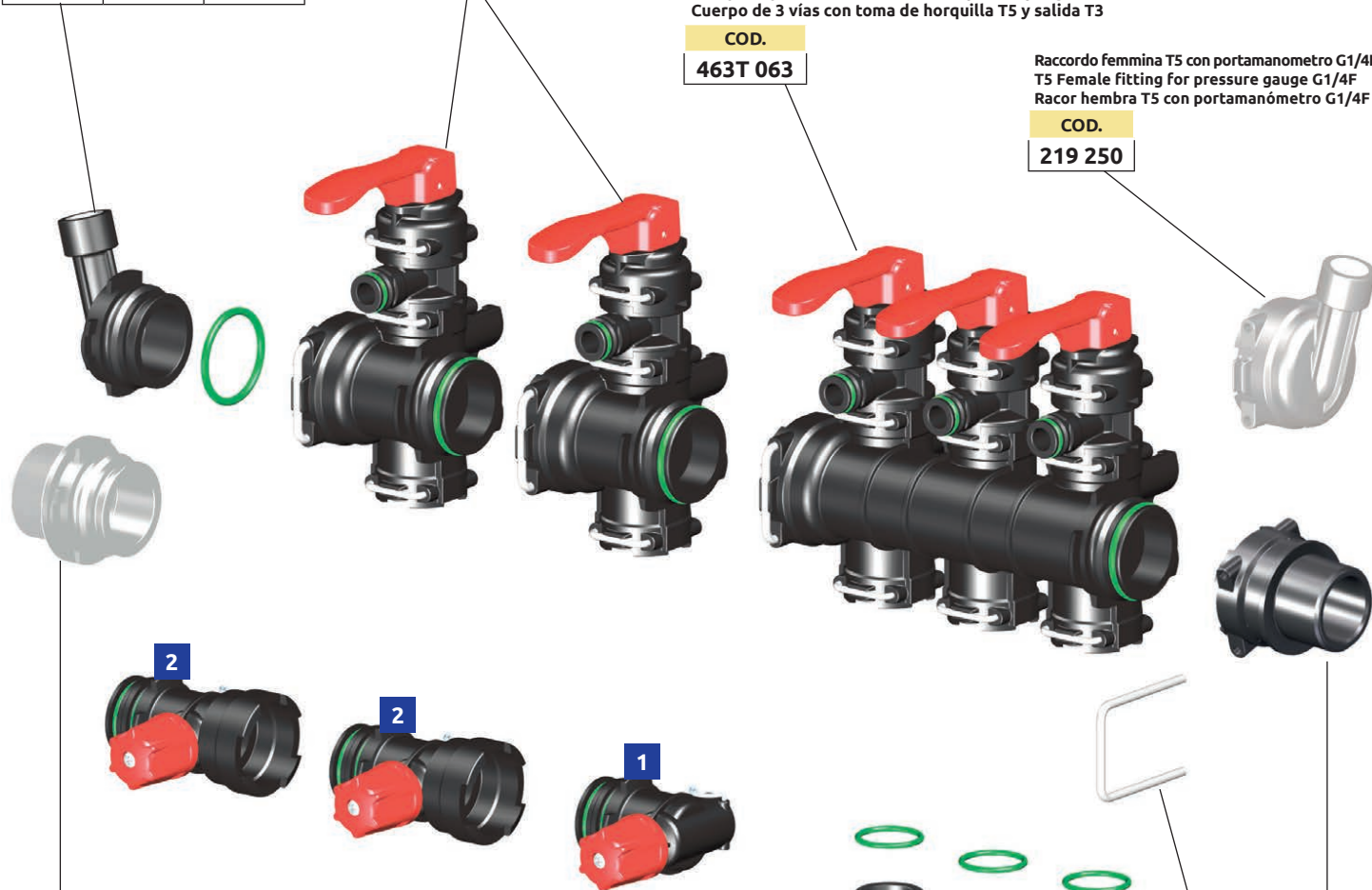

Ritorni calibrati con attacco a forchetta (compresa)  
Metered by-pass with fork coupling (included)  
Retornos calibrados con toma de horquilla (incluida)

Pos.	Descr.	COD.
1	Ritorno calibrato terminale per valvole manuali End metered by-pass for manual valves Retorno calibrado terminal para válvulas manuales	4631010.800
2	Ritorno calibrato T4 per valvole manuali T4 metered by-pass for manual valves Retorno calibrado T4 para válvulas manuales	4631010.810

**T5**  
fork  
coupling

Raccordi di completamento con attacco a forchetta T5 e O'ring nel capitolo:  
End fittings with T5 fork coupling and O-ring in chapter:  
Empalmes de terminación con toma de horquilla T5 y O'ring en el capítulo:

**FITTINGS**

**T3**  
fork  
coupling

Raccordi di completamento con attacco a forchetta T3 e O'ring nel capitolo:  
End fittings with T3 fork coupling and O-ring in chapter:  
Empalmes de terminación con toma de horquilla T3 y O'ring en el capítulo:

**FITTINGS**

**T5**  
fork  
coupling

Raccordi di completamento con attacco a forchetta T5 e O'ring nel capitolo:  
End fittings with T5 fork coupling and O-ring in chapter:  
Empalmes de terminación con toma de horquilla T5 y O'ring en el capítulo:

**FITTINGS**

**! IMPORTANTE! - IMPORTANT! - ¡IMPORTANTE!**

Raccordi di completamento con attacco a forchetta da ordinare **SEPARATEMENTE** dal capitolo "FITTINGS"

End fork fittings must be ordered **SEPARATELY** in the chapter "FITTINGS"

Empalmes de terminación con toma de horquilla deben pedirse **POR SEPARADO** a la sección "FITTINGS"

# 463T

## VALVOLE SEZIONE DI BARRA CON ATTACCO A FORCHETTA BOOM SECTION VALVES WITH FORK COUPLING VÁLVULAS SECCION DE BARRA CON CONEXIÓN DE HORQUILLA

Gruppi manuali ON/OFF

ON/OFF manual control units

Grupos manuales ON/OFF

Raccordo maschio T5 con portamanometro G1/4F  
T5 Male fitting with pressure gauge G1/4F  
Racor macho T5 con portanómetro G1/4F

COD.	O'ring	
	COD. (EPDM)	COD. (Viton®)
219 350	G11063	G11063V

COD.  
463T 053

Corpo a 3 vie con attacco a forchetta T5 e uscita T3  
3-way body with T5 fork and T3 output couplings  
Cuerpo de 3 vías con toma de horquilla T5 y salida T3

Corpo singolo con attacco a forchetta T5 e uscita T3  
Single body with T5 fork and T3 output couplings  
Cuerpo individual con toma de horquilla T5 y salida T3

COD.  
463T 051

Raccordo femmina T5 con portamanometro G1/4F  
T5 Female fitting for pressure gauge G1/4F  
Racor hembra T5 con portanómetro G1/4F

COD.  
219 250

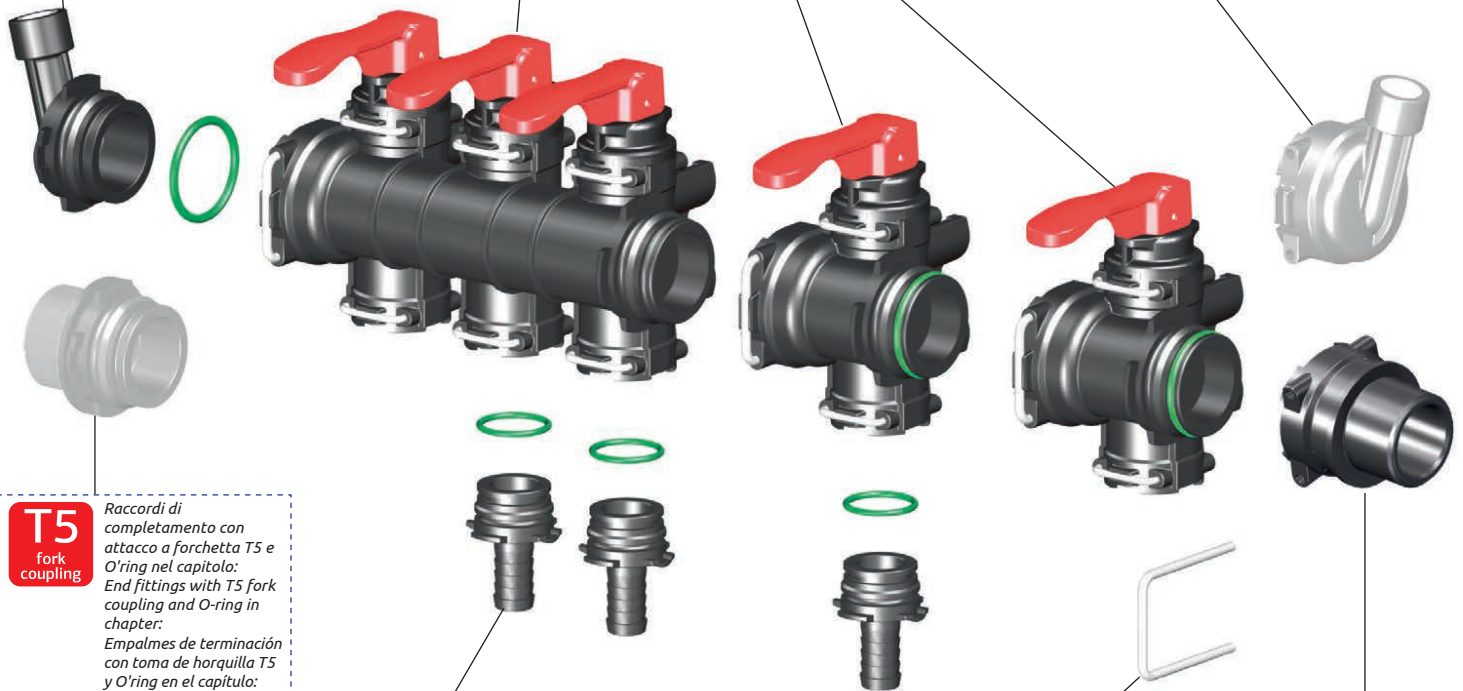

**T5**  
fork  
coupling

Raccordi di completamento con attacco a forchetta T5 e O'ring nel capitolo:  
End fittings with T5 fork coupling and O-ring in chapter:  
Empalmes de terminación con toma de horquilla T5 y O'ring en el capítulo:

**FITTINGS**

**T3**  
fork  
coupling

Raccordi di completamento con attacco a forchetta T3 e O'ring nel capitolo:  
End fittings with T3 fork coupling and O-ring in chapter:  
Empalmes de terminación con toma de horquilla T3 y O'ring en el capítulo:

**FITTINGS**

Forchetta  
Fork  
Horquilla

COD.  
010 005

**T5**  
fork  
coupling

Raccordi di completamento con attacco a forchetta T5 e O'ring nel capitolo:  
End fittings with T5 fork coupling and O-ring in chapter:  
Empalmes de terminación con toma de horquilla T5 y O'ring en el capítulo:

**FITTINGS**

**! IMPORTANTE! - IMPORTANT! - ¡IMPORTANTE!**

Raccordi di completamento con attacco a forchetta da ordinare **SEPARATAMENTE** dal capitolo "FITTINGS"  
End fork fittings must be ordered **SEPARATELY** in the chapter "FITTINGS"  
Empalmes de terminación con toma de horquilla deben pedirse **POR SEPARADO** a la sección "FITTINGS"

# GRUPPI DI COMANDO componibili

## MODULAR CONTROL UNITS

### GRUPOS DE MANDOS MODULARES

#### Sistema componibile per gruppi di comando

- Minori costi di gestione delle scorte
- Flessibilità di impiego
- Maggiore rapidità di risposta al cliente

#### Modular system for control units

- Lower management cost of the supply
- Flexibility of use
- Shorter response time to the customer

#### Sistema modulare para grupos de mandos

- Menor costo de gestión de las existencias
- Flexibilidad de empleo
- Mayor rapidez de respuesta al cliente

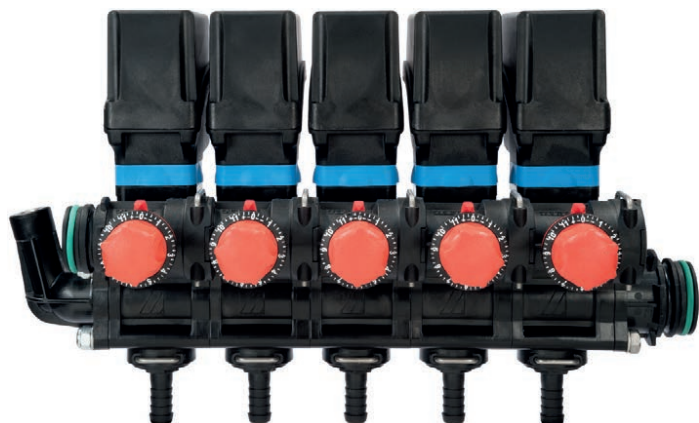

Gruppi valvole di sezione serie 863 elettriche e 463 manuali.  
Series 863 and 463 section valves, with electric and manual controls.  
Grupos válvulas de sección serie 863 eléctricas y 463 manuales.

**Pag. - Page**  
**Pág. B-49**



Collettori con valvola di scarico pressione  
Manifold with bleeder valve  
Colectores con válvula de descarga presión

**Pag. - Page**  
**Pág. B-54**

Flussometri elettromagnetici ORION2.  
ORION2 electromagnetic flow-meters.  
Caudalímetros electromagnéticos ORION2.

**Pag. - Page - Pág. B-18**



Flussometri a palette WOLF.  
WOLF paddle flow-meter.  
Caudalímetros de paletas WOLF.

**Pag. - Page - Pág. B-18**







Filtri in linea serie 322 e 326 con e senza valvola di scarico.  
Series 322 and 326 line filters with and without drain valve.  
Filtros en línea serie 322 y 326 con o sin válvula de descarga.

**Pag. - Page - Pág. B-19/B-47**



Gruppo valvola generale serie 871 + valvola proporzionale serie 863 con attacco a forchetta T5.  
Series 871 main valve unit + series 863 proportional valve with T5 fork connector.  
Grupo válvula general serie 871 + válvula proporcional serie 863 con empalme con acople de horquilla T5.

**Pag. - Page - Pág. B-34**



Gruppo valvola generale serie 864 + valvola proporzionale serie 873 con attacco a forchetta T5.  
Series 864 main valve unit + series 873 proportional valve with T5 fork connector.  
Grupo válvula general serie 864 + válvula proporcional serie 873 con empalme con acople de horquilla T5.

**Pag. - Page - Pág. B-36**

# VALVOLE DI COMANDO GENERALE MAIN CONTROL VALVES VÁLVULAS DE MANDO GENERAL

# 871 T5

## Valvola di comando generale con valvola proporzionale elettrica o manuale e attacco a forchetta T5

- Struttura in Nylon® rinforzato con fibra di vetro
- Particolari interni in Delrin® e acciaio Inox AISI 303
- Guarnizioni in Viton®
- Basso assorbimento di corrente
- Composta dalle valvole generale serie 871 e proporzionale serie 863

## Main control valve with manual/ electric proportional valve and T5 fork connector

- Fibreglass-reinforced Nylon body
- Internal parts in Delrin® and AISI 303 stainless steel
- Gaskets made of Viton®
- Low power consumption
- Consisting of series 871 main valve and series 863 proportional valve

## Válvula de mando general de con válvula proporcional eléctrica o manual y empalme con acople de horquilla T5

- Estructura de Nylon reforzado con fibra de vidrio
- Piezas interiores de Delrin® y acero Inox AISI 303
- Juntas de Viton®
- Bajo consumo de amperaje
- Compuesta por válvulas general serie 871 proporcional serie 863



COD. CODE CÓD.	⚡	⌚		⏸	⚒ @ 1.5 bar @ 22 PSI		∅		⏸	⚒		∅ IN		∅ BY PASS		
		bar	PSI		ON-OFF	lt/1'	US GPM	mm		inches	ON-OFF	lt/1'	US GPM	mm	type	mm
<b>871 520D50</b>	12 Vdc 1 A	20	290	14 sec.	60	16	13	1/2"	0.6 sec.	150	40	19	A	25 30 32 35 1" 1/4 (♦♦)		
<b>871 520E50</b>					100	26	19	3/4"				25	1"		30	A - B
<b>871 520F50</b>					150	40	25	1"				32	A			
<b>871 520Q50</b>	12 Vdc 1 A	20	290	7 sec.	60	16	13	1/2"	0.6 sec.	150	40	19	A	25 30 32 35 1" 1/4 (♦♦)		
<b>871 520P50</b>					100	26	19	3/4"				25	1"		30	A
<b>871 520R50</b>					150	40	25	1"				32	A			

Designed for use with BRAVO and DELTA computers



COD. CODE CÓD.	⚡	⌚		⚒ @ 1.5 bar @ 22 PSI	∅		⏸	⚒		∅ IN		∅ BY PASS				
		bar	PSI		ON-OFF	lt/1'		US GPM	mm	inches	ON-OFF	lt/1'	US GPM	mm	type	mm
<b>871 520A50</b>	12 Vdc 0,5 A	20	290	0.6 sec.	60	16	13	1/2"	0.6 sec.	150	40	19	A	25 30 32 35 1" 1/4 (♦♦)		
<b>871 520B50</b>					100	26	19	3/4"				25	1"		30	A - B
<b>871 520C50</b>					150	40	25	1"				32	A			

- ♦ Massima portata della valvola di massima pressione a 3 bar / 45 PSI (portagomma con Venturi).
- ♦ Maximum flow rate of the relief valve at 3 bar / 45 PSI (hose tail with Venturi)
- ♦ Máximo caudal de la válvula de presión máx. a 3 bar / 45 PSI (racor puerta manguera con Venturi)

- ♦♦ ∅ e colore del portagomma by-pass in funzione della portata pompa.
- ♦♦ ∅ and colour of the by-pass hose fitting depend on the pump case.
- ♦♦ ∅ y color del portamanguera by-pass en función del caudal de la bomba.

∅ BY PASS (mm)	MAX POMPA / PUMP
	lt/1' US GPM
25	70 19
30 - 32 - 1" 1/4	120 32
35 - 1" 1/4	180 48

Specificare il diametro dei portagomma indicati in tabella.

Specify the diameter of the hose fittings indicated in the table.

Especifiquen el diámetro de los portamangueras indicados en la tabla.

Cavi e spine DIN a 3 fili  
3-wires DIN cables and plugs  
Cables y tomas DIN a 3 hilos

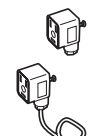

COD. / CODE / CÓD.  
**ECS0033**

COD. / CODE / CÓD.  
**8650900.140 (1.3 m)**

### Valvola di comando generale con valvola proporzionale manuale e attacco a forchetta T5

- Struttura in Nylon® rinforzato con fibra di vetro
- Particolari interni in Delrin® e acciaio Inox AISI 303
- Guarnizioni in Viton®
- Composta dalle valvole generale serie 471 e proporzionale serie 463

### Main control valve with manual proportional valve and T5 fork connector

- Fibreglass-reinforced Nylon body
- Internal parts in Delrin® and AISI 303 stainless steel
- Gaskets made of Viton®
- Consisting of series 471 main valve and series 463 proportional valve

### Válvula de mando general con válvula proporcional manual y empalme con acople de horquilla T5

- Estructura de Nylon reforzado con fibra de vidrio
- Piezas interiores de Delrin® y acero Inox AISI 303
- Juntas de Viton®
- Compuesta por válvulas general serie 471 proporcional serie 463



COD. CODE CÓD.	Pressure		Flow Rate		Ø		Flow Rate		Ø IN		Ø BY PASS
	bar	PSI	lt/1'	US GPM	mm	inches	lt/1'	US GPM	mm	type	
471 220A50	20	290	60	16	13	1/2"	150	40	19	A	25 30 32 35 1" 1/4 (♦♦)
471 220B50			100	26	19	3/4"			25	A - B	
471 220C50			150	40	25	1"			30	A	

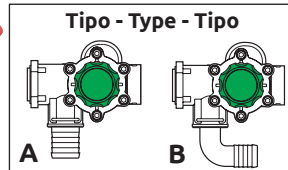

- ♦ Massima portata della valvola di massima pressione a 3 bar / 45 PSI (portagomma con Venturi).
- ♦ Maximum flow rate of the relief valve at 3 bar / 45 PSI (hose tail with Venturi)
- ♦ Máximo caudal de la válvula de presión máx. a 3 bar / 45 PSI (racor puerta manguera con Venturi)

- ♦♦ Ø e colore del portagomma by-pass in funzione della portata pompa.
- ♦♦ Ø and colour of the by-pass hose fitting depend on the pump case.
- ♦♦ Ø y color del portamanguera by-pass en función del caudal de la bomba.

Ø BY PASS (mm)	MAX POMPA / PUMP	
	lt/1'	US GPM
25	70	19
30 - 32 - 1" 1/4	120	32
35 - 1" 1/4	180	48

Specificare il diametro dei portagomma indicati in tabella.  
Specify the diameter of the hose fittings indicated in the table.  
Especificquen el diámetro de los portamangueras indicados en la tabla.



**VALVOLE DI COMANDO GENERALE**  
**MAIN CONTROL VALVES**  
**VÁLVULAS DE MANDO GENERAL**

**864 - 464** **T5**

**Valvola di comando generale con valvola proporzionale elettrica e attacco a forchetta T5**

- Struttura in Nylon® rinforzato con fibra di vetro
- Particolari interni in Delrin® e acciaio Inox AISI 303
- Guarnizioni in Viton®
- Fusibile interno resettabile (togliendo l'alimentazione per 20 secondi)
- Ridotto assorbimento
- Composta dalle valvole generale serie 864 e proporzionale serie 873

**Main control valve with electric proportional valve and T5 fork connector**

- Fibreglass-reinforced Nylon body
- Internal parts in Delrin® and AISI 303 stainless steel
- Gaskets made of Viton®
- Internal resettable fuse (disconnecting power for 20 seconds)
- Low power consumption
- Consisting of series 864 main valve and series 873 proportional valve

**Válvula de mando general con válvula proporcional eléctrica y empalme con acople de horquilla T5**

- Estructura de Nylon reforzado con fibra de vidrio
- Piezas interiores de Delrin® y acero Inox AISI 303
- Juntas de Viton®
- Fusible interior rearmable (parando l'alimentacion para 20 sec.)
- Bajo consumo de amperaje
- Compuesta por válvulas general serie 864 proporcional serie 873



Cavi e spine DIN a 3 fili  
 3-wires DIN cables and plugs  
 Cables y tomas DIN a 3 hilos

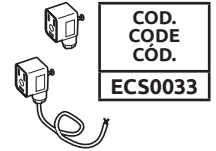

**COD. CODE Cód.**  
**8650900.140 (1.3 m)**

COD. CODE Cód.	⚡	⌚		⌚	⚒ @ 1.5 bar @ 22 PSI		∅		⌚	⚒		∅ IN	∅ BY PASS
		bar	PSI		ON-OFF	lt/1'	US GPM	mm		inches	ON-OFF		
<b>864 52N50</b>	12 Vdc 3,5 A	20	290	14 sec.	200	53	25	1"	1 sec.	200	53	25 30 35 38	35 40 (♦♦)
<b>864 52M50</b>					240	63	30	---					
<b>864 52U50</b>	12 Vdc 3,5 A	20	290	7 sec.	200	53	25	1"	1 sec.	200	53	25 30 35 38	35 40 (♦♦)
<b>864 52T50</b>					240	63	30	---					

Designed for use with BRAVO and DELTA computers



**Valvola di comando generale con valvola proporzionale manuale e attacco a forchetta T5**

- Struttura in Nylon® rinforzato con fibra di vetro
- Particolari interni in Delrin® e acciaio Inox AISI 303
- Guarnizioni in Viton®
- Composta dalle valvole generale serie 464 e proporzionale serie 473

**Main control valve with manual proportional valve and T5 fork connector**

- Fibreglass-reinforced Nylon body
- Internal parts in Delrin® and AISI 303 stainless steel
- Gaskets made of Viton®
- Consisting of series 464 main valve and series 473 proportional valve

**Válvula de mando general con válvula proporcional manual y empalme con acople de horquilla T5**

- Estructura de Nylon reforzado con fibra de vidrio
- Piezas interiores de Delrin® y acero Inox AISI 303
- Juntas de Viton®
- Compuesta por válvulas general serie 464 proporcional serie 473



COD. CODE Cód.	⌚		⚒ @ 1.5 bar @ 22 PSI		∅		⚒		∅ IN	∅ BY PASS
	bar	PSI	lt/1'	US GPM	mm	inches	lt/1'	US GPM		
<b>464 22J50</b>	20	290	200	53	25	1"	200	53	25 30 35 38	35 40 (♦♦)
<b>464 22L50</b>			240	63	30	---				

- ♦♦ massima portata della valvola di massima pressione a 3 bar / 45 PSI (portagomma con Venturi).
- ♦♦ maximum flow rate of the relief valve at 3 bar / 45 PSI (hose tail with Venturi)
- ♦♦ máximo caudal de la válvula de presión máx. a 3 bar / 45 PSI (racor puerta manguera con Venturi)

- ♦♦ ∅ e colore del portagomma by-pass in funzione della portata pompa.
- ♦♦ ∅ and colour of the by-pass hose fitting depend on the pump case.
- ♦♦ ∅ y color del portamanguera by-pass en función del caudal de la bomba.

∅ BY PASS (mm)	MAX POMPA / PUMP	
	lt/1'	US GPM
35	60	16
35	120	32
40	180	48
40	280	74

Specificare il diametro dei portagomma indicati in tabella.

Specify the diameter of the hose fittings indicated in the table.

Especificar el diámetro de los portamangueras indicados en la tabla.

### Valvola di comando generale con valvola di massima pressione regolabile

- Struttura in Nylon® rinforzato con fibra di vetro
- Particolari interni in Delrin® e acciaio Inox AISI 303
- Guarnizioni in Viton®
- Fusibile interno resettabile (togliendo l'alimentazione per 20 secondi)

### Main control valve with adjustable pressure relief valve

- Fibreglass-reinforced Nylon body
- Internal parts in Delrin® and AISI 303 stainless steel
- Gaskets made of Viton®
- Internal resettable fuse (disconnecting power for 20 seconds)

### Válvula de mando general con válvula de máxima presión regulable

- Estructura de Nylon reforzado con fibra de vidrio
- Piezas interiores de Delrin® y acero Inox AISI 303
- Juntas de Viton®
- Fusible interior rearmable (parando l'alimentación para 20 sec.)

### Azionamento elettrico



### Electric operation

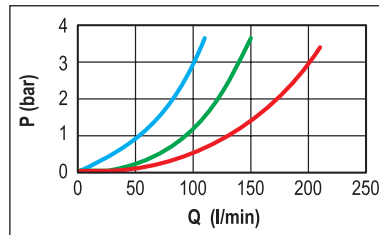

Pressione residua valvola in scarico (portagomma con risucchio).  
Back pressure during dump phase (hose tail with suck back device).  
Presión residual durante la descarga (racor portamanguera con reaspiración).

Ø BY PASS:	25 mm
	30-32 mm - 1" 1/4
	35 mm - 1" 1/4

### Accionamiento eléctrico



	A	B	C
mm	225	180	246
inches	8.8"	7.1"	9.7"

COD. CODE CÓD.	Pressure		ON-OFF	12 Vdc 0.5 A	150	40	Ø IN		Ø BY PASS
	bar	PSI					mm	type	
871 0501	10	145	0.6 sec.				19	A	25 30 32 35 1" 1/4 (♦♦)
871 0502	20	290					25	A - B	
871 0503	30	435					30	A	

### Azionamento manuale

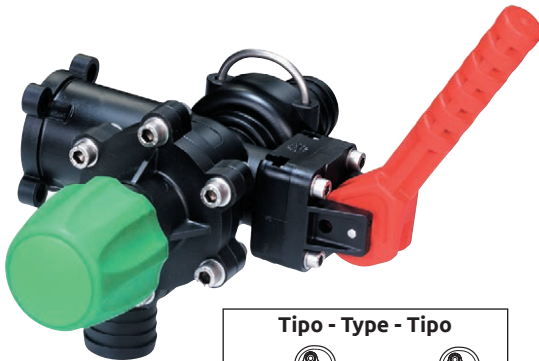

### Manual operation

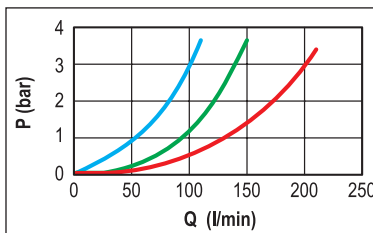

Pressione residua valvola in scarico (portagomma con risucchio).  
Back pressure during dump phase (hose tail with suck back device).  
Presión residual durante la descarga (racor portamanguera con reaspiración).

Ø BY PASS:	25 mm
	30-32 mm - 1" 1/4
	35 mm - 1" 1/4

### Accionamiento manual



	A	B	C
mm	220-277	180	246
inches	8.6"-10.9"	7.1"	9.7"

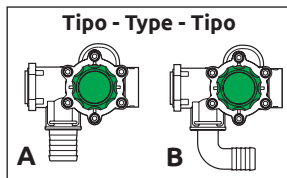

COD. CODE CÓD.	Pressure		150	40	Ø IN		Ø BY PASS
	bar	PSI			mm	type	
471 201	10	145			19	A	25 30 32 35 1" 1/4 (♦♦)
471 202	20	290			25	A - B	
471 203	30	435			30	A	

- ♦ Massima portata della valvola di massima pressione a 3 bar / 45 PSI (portagomma con Venturi).
- ♦ Maximum flow rate of the relief valve at 3 bar / 45 PSI (hose tail with Venturi)
- ♦ Máximo caudal de la válvula de presión máx. a 3 bar / 45 PSI (racor puerta manguera con Venturi)

- ♦♦ Ø e colore del portagomma by-pass in funzione della portata pompa.
- ♦♦ Ø and colour of the by-pass hose fitting depend on the pump case.
- ♦♦ Ø y color del portamanguera by-pass en función del caudal de la bomba.

Ø BY PASS (mm)	MAX POMPA / PUMP	
	lt/1'	US GPM
25	70	19
30-32 - 1" 1/4	120	32
35 - 1" 1/4	180	48

Specificare il diametro dei portagomma indicati in tabella.

Specify the diameter of the hose fittings indicated in the table.

Especificquen el diámetro de los portamangueras indicados en la tabla.

Cavi e spine DIN a 3 fili  
3-wires DIN cables and plugs  
Cables y tomas DIN a 3 hilos



COD. / CODE / CÓD.  
**ECS0033**



COD. / CODE / CÓD.  
**8650900.140 (1.3 m)**

# VALVOLE DI COMANDO GENERALE MAIN CONTROL VALVES VÁLVULAS DE MANDO GENERAL

# 864 - 464

## Valvola di comando generale con valvola di massima pressione regolabile

- Struttura in Nylon® rinforzato con fibra di vetro
- Particolari interni in Delrin® e acciaio Inox AISI 303
- Guarnizioni in Viton®
- Basso assorbimento di corrente

## Main control valve with adjustable pressure relief valve

- Fibreglass-reinforced Nylon body
- Internal parts in Delrin® and AISI 303 stainless steel
- Gaskets made of Viton®
- Low power consumption

## Válvula de mando general con válvula de máxima presión regulable

- Estructura de Nylon reforzado con fibra de vidrio
- Piezas interiores de Delrin® y acero Inox AISI 303
- Juntas de Viton®
- Bajo consumo de amperaje

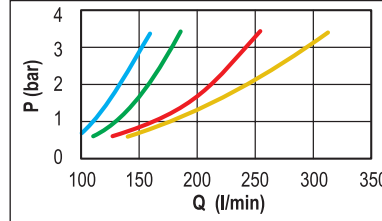

Pressione residua valvola in scarico (portagomma con risucchio).  
Back pressure during dump phase (hose tail with suck back device).  
Presión residual durante la descarga (racor portamanguera con reaspiracion).

Ø BY PASS: 35 mm (Blue) 35 mm (Red) 35 mm (Green) 40 mm (Yellow)

COD. CODE CÓD.	Pressure		ON-OFF	Power	Flow	Flow	Ø IN	Ø BY PASS
	bar	PSI						
864 0501	10	145	1 sec.	12 Vdc 3 A	200	53	25	35 40
864 0502	20	290					35	38

CE, Safety icons, Dimensions table:

	A	B	C
mm	270	309	175
inches	10.6"	12.2"	6.9"

Cavi e spine DIN a 3 fili  
3-wires DIN cables and plugs  
Cables y tomas DIN a 3 hilos

COD. / CODE / CÓD.  
8650900.140 (1.3 m)

COD. / CODE / CÓD.  
ECS0033

## Valvola di comando generale con valvola di massima pressione regolabile

- Struttura in Nylon® rinforzato con fibra di vetro
- Particolari interni in Delrin® e acciaio Inox AISI 303
- Guarnizioni in Viton®

## Main control valve with adjustable pressure relief valve

- Fibreglass-reinforced Nylon body
- Internal parts in Delrin® and AISI 303 stainless steel
- Gaskets made of Viton®

## Válvula de mando general con válvula de máxima presión regulable

- Estructura de Nylon reforzado con fibra de vidrio
- Piezas interiores de Delrin® y acero Inox AISI 303
- Juntas de Viton®

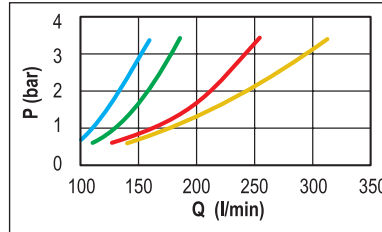

Pressione residua valvola in scarico (portagomma con risucchio).  
Back pressure during dump phase (hose tail with suck back device).  
Presión residual durante la descarga (racor portamanguera con reaspiracion).

Ø BY PASS: 35 mm (Blue) 35 mm (Red) 35 mm (Green) 40 mm (Yellow)

COD. CODE CÓD.	Pressure		Flow	Flow	Ø IN	Ø BY PASS
	bar	PSI				
464 201	10	145	200	53	25	35 40
464 202	20	290			35	38

Safety icons, Dimensions table:

	A	B	C
mm	214-388	299	171
inches	8.5"-15"	11.8"	6.7"

- ♦♦ massima portata della valvola di massima pressione a 3 bar / 45 PSI (portagomma con Venturi).
- ♦♦ maximum flow rate of the relief valve at 3 bar / 45 PSI (hose tail with Venturi)
- ♦♦ máximo caudal de la válvula de presión máx. a 3 bar / 45 PSI (racor puerta manguera con Venturi)

- ♦♦ Ø e colore del portagomma by-pass in funzione della portata pompa.
- ♦♦ Ø and colour of the by-pass hose fitting depend on the pump case.
- ♦♦ Ø y color del portamanguera by-pass en función del caudal de la bomba.

Ø BY PASS (mm)	MAX POMPA / PUMP (lt/' / US GPM)
35	120
180	48
40	280
	74

Specificare il diametro dei portagomma indicati in tabella.

Specify the diameter of the hose fittings indicated in the table.

Especifiquen el diámetro de los portamangueras indicados en la tabla.

# ACCESSORI PER VALVOLE MODULARI ACCESSORIES FOR MODULAR VALVES ACCESORIOS PARA VÁLVULAS MODULARES

## 871-471

COD. CODE CÓD.	Ø	MAT. (*)
463 000.130	G 3/4 (BSP)	1
463 000H.130	G 3/4 (BSP)	2
463 000.131	3/4" NPT	1
463 000.140	G 1 (BSP)	1
463 000H.140	G 1 (BSP)	2
463 000.141	1" NPT	1
463 000.150	G 1 1/4 (BSP)	1
463 000.151	1" 1/4 NPT	1

COD. CODE CÓD.	MAT. (*)
473 000.010	1

COD. / CODE / CÓD.	Ø	Ør	MAT. (*)
471 202.B50	G 1 1/4 (BSP)		1
471 202.B51	G 1 1/4 (BSP)	19 mm	1
471 202.B52	G 1 1/4 (BSP)	16 mm	1

Ør  
diámetro interno portagomma con venturi  
hose tail with venturi internal diameter  
diámetro interior racor porta manguera con venturi

COD. CODE CÓD.	Ø	MAT. (*)
471 202.C25	25 mm	1
471 202.C30	30 mm	1

COD. CODE CÓD.	Ø	MAT. (*)
463 000.157	T5	1

COD. CODE CÓD.	Ø	MAT. (*)
463 000.132	G 3/4 (BSP)	1
463 000.133	3/4" NPT	1
463 000.142	G 1 (BSP)	1
463 000.143	1" NPT	1

COD. CODE CÓD.	Ø	MAT. (*)
473 001.C25C	25 mm	1

COD. CODE CÓD.	Ø	MAT. (*)
473 001.A19C	19 mm	1
473 001.A25C	25 mm	1
473 001.A30C	30 mm	1
473 001.A32C	32 mm	1

COD. / CODE / CÓD.	Ø	MAX POMPA PUMP		MAT. (*)
		lt/1'	US GPM	
471 202.A40	25 mm	70	19	1
471 202.A41	30 mm	120	32	1
471 202.A43	32 mm	120	32	1
471 202.A45	35 mm	180	48	1

COD. CODE CÓD.	Ø	MAT. (*)
473 001.B30C	G 3/4 (BSP)	1
473 001.B40C	G 1 (BSP)	1
473 001.B50C	G 1 1/4 (BSP)	1

(\*) materiale 1= Nylon  
2= Ottone  
(\*) material 1= Nylon  
2= Brass  
(\*) material 1= Nylon  
2= Latón

## 864-464

COD. CODE CÓD.	Ø	MAT. (*)
464 400.028	473	1
464 400.029	463	1

COD. CODE CÓD.	Ø	MAT. (*)
464 400.023	G 3/4 (BSP)	1
464 400.024	G 1 (BSP)	1
464 400.025	G 1 1/4 (BSP)	1

(\*) materiale 1= Nylon  
(\*) material 1= Nylon  
(\*) material 1= Nylon

COD. CODE CÓD.	Ø	MAT. (*)
464 400.026	T5	1

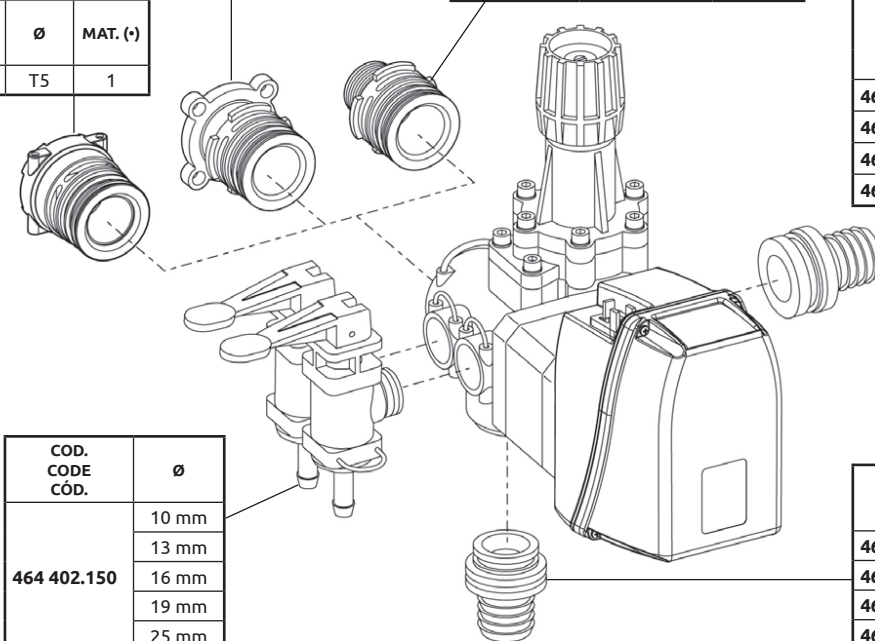

COD. CODE CÓD.	Ø	MAX POMPA / PUMP		MAT. (*)
		lt/1'	US GPM	
464 402.A40	35 mm	60	16	1
464 402.A41	35 mm	120	32	1
464 402.A42	35 mm	180	48	1
464 402.A43	40 mm	280	74	1

COD. CODE CÓD.	Ø
464 402.150	10 mm
	13 mm
	16 mm
	19 mm
	25 mm

COD. CODE CÓD.	Ø	MAT. (*)
464 402.A90	25 mm	1
464 402.A91	30 mm	1
464 402.A92	35 mm	1
464 402.A93	38 mm	1

# VALVOLE DI REGOLAZIONE PROPORZIONALI PROPORTIONAL CONTROL VALVES VÁLVULAS DE REGULACIÓN PROPORCIONAL

# 863 - 463

## Valvola di regolazione proporzionale elettrica

- Regola il flusso nei gruppi di distribuzione che effettuano trattamenti proporzionali ai giri motore (DPM)
- Struttura in Nylon® rinforzato con fibra di vetro
- Particolari interni in Delrin® e acciaio Inox AISI 303
- Guarnizioni in Viton®
- Fusibile interno resettabile (togliendo l'alimentazione per 20 secondi)

## Electric proportional control valve

- Adjusts the flow in the control units in which treatments vary in proportion with engine rpm (DPM)
- Fibreglass-reinforced Nylon body
- Internal parts in Delrin® and AISI 303 stainless steel
- Gaskets made of Viton®
- Internal resettable fuse (disconnecting power for 20 seconds)

## Válvula de regulación proporcional eléctrica

- Regula el flujo en los grupos de distribución que efectúan tratamientos proporcionales a las revoluciones del motor (DPM)
- Estructura de Nylon reforzado con fibra de vidrio
- Piezas interiores de Delrin® y acero Inox AISI 303
- Juntas de Viton®
- Fusible interior rearmable (parando l'alimentacion para 20 sec.)

## Valvola di regolazione proporzionale elettrica



## Electric proportional control valve

COD. CODE CÓD.	Pressure		ON-OFF	Voltage	Flow		Ø*	
	bar	PSI			lt/1'	US GPM	mm	inches
<b>863 0026</b>	40	580	14 sec.	12 Vdc 0.5 A	25	6	13	1/2"
<b>863 0022</b>					60	16	13	1/2"
<b>863 0020</b>					100	26	19	3/4"
<b>863 0024</b>					150	40	25	1"
<b>863 0026S</b>	40	580	7 sec.	12 Vdc 0.5 A	25	6	13	1/2"
<b>863 0022S</b>					60	16	13	1/2"
<b>863 0020S</b>					100	26	19	3/4"
<b>863 0024S</b>					150	40	25	1"

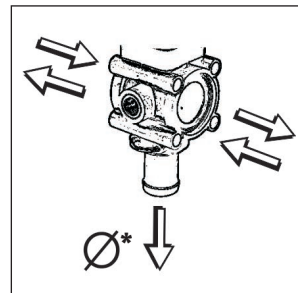
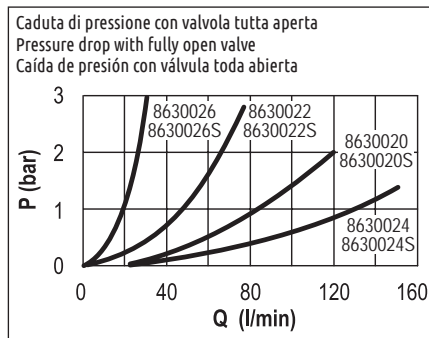

Valvola specifica per l'utilizzo con i computer BRAVO e DELTA: nuovo sistema di azionamento a diametro maggiorato, con trattamento antiusura per garantire una lunga durata.

Specific valve for use with BRAVO and DELTA computers: new larger-diameter drive system, with wear-proof coating for a longer life.

Válvula específica para el uso con los ordenadores BRAVO y DELTA: nuevo sistema de accionamiento de mayor diámetro, con tratamiento anti desgaste para garantizar una prolongada durabilidad.



	A	B	C
mm	62	217	111
inches	2.5"	8.5"	4.5"

Flange di accoppiamento e accessori per valvole modulari, pag. B-52

Adapters and accessories for modular valves, page B-52

Bridas de acoplamiento y accesorios para válvulas modulares, pag. B-52

Cavi e spine DIN a 3 fili  
3-wires DIN cables and plugs  
Cables y tomas DIN a 3 hilos



COD. / CODE / CÓD.
<b>ECS0033</b>

COD. / CODE / CÓD.
<b>8650900.140</b> (1.3 m)



## Valvola di regolazione proporzionale manuale



## Manual proportional control valve

COD. CODE CÓD.	Pressure		Flow	Ø		
	bar	PSI				
<b>463 072</b>	40	580	60	16	13	1/2"
<b>463 070</b>			100	26	19	3/4"
<b>463 074</b>			150	40	25	1"

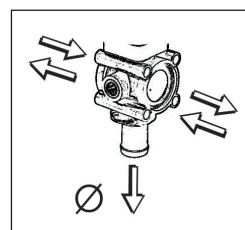
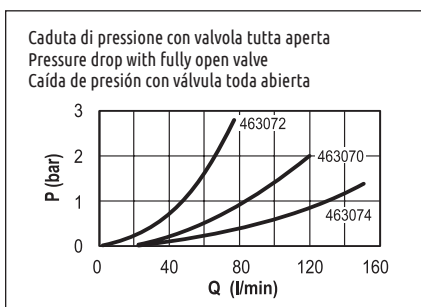

## Válvula de regulación proporcional manual

	A	B	C
mm	62	206	63
inches	2.5"	8"	2.5"



### Valvola di regolazione proporzionale

- Regola il flusso nei gruppi di distribuzione che effettuano trattamenti proporzionali ai giri motore (DPM)
- Struttura in Nylon® rinforzato
- Particolari interni in acciaio Inox AISI 303
- Guarnizioni in Viton®
- Fusibile interno resettabile (togliendo l'alimentazione per 20 secondi)
- Portata 240 l/min

### Proportional control valve

- Adjusts the flow in the control units in which treatments vary in proportion with engine rpm (DPM)
- Reinforced Nylon body
- Internal parts in AISI 303 stainless steel
- Gaskets made of Viton®
- Internal resettable fuse (disconnecting power for 20 seconds)
- Flow rate 240 l/min (63 US GPM)**

### Válvula de regulación proporcional

- Regula el flujo en los grupos de distribución que efectúan tratamientos proporcionales a las revoluciones del motor (DPM)
- Estructura de Nylon reforzado
- Piezas interiores de acero Inox AISI 303
- Juntas de Viton®
- Fusible interior rearmable (parando l'alimentación para 20 sec.)
- Caudal 240 l/min**

### Valvola di regolazione proporzionale elettrica



### Electric proportional control valve

COD. CODE CÓD.	Pressure		sec.	12 Vdc 0,5 A	Flow rate		Ø*	
	bar	PSI			lt/1'	US GPM	mm	inches
<b>873 0022</b>	20	290	14	12 Vdc 0,5 A	190	50	25	1"
<b>873 0020</b>					240	63	30	---
<b>873 0022S</b>	20	290	7	12 Vdc 0,5 A	190	50	25	1"
<b>873 0020S</b>					240	63	32	1" 1/4

Caduta di pressione con valvola tutta aperta  
Pressure drop with fully open valve  
Caída de presión con válvula toda abierta

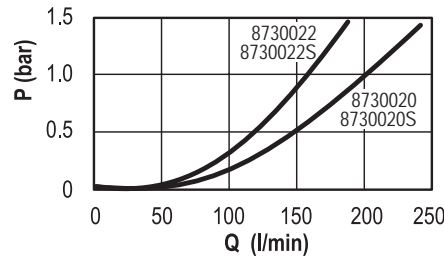

### Válvula de regulación proporcional eléctrica



Valvola specifica per l'utilizzo con i computer BRAVO e DELTA: nuovo sistema di azionamento a diametro maggiorato, con trattamento antiusura per garantire una lunga durata.

Specific valve for use with BRAVO and DELTA computers: new larger-diameter drive system, with wear-proof coating for a longer life.

Válvula específica para el uso con los ordenadores BRAVO y DELTA: nuevo sistema de accionamiento de mayor diámetro, con tratamiento anti desgaste para garantizar una prolongada durabilidad.

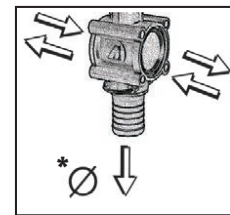

	A	B	C
mm	62	240	111
inches	2,5"	9,5"	4,5"



Flange di accoppiamento e accessori per valvole modulari, pag. B-42

Adapters and accessories for modular valves, page B-42

Bridas de acoplamiento y accesorios para válvulas modulares, pág. B-42

Cavi e spine DIN a 3 fili  
3-wires DIN cables and plugs  
Cables y tomas DIN a 3 hilos



COD. / CODE / CÓD.  
**ECS0033**

COD. / CODE / CÓD.  
**8650900.140 (1.3 m)**



### Valvola di regolazione proporzionale manuale



### Manual proportional control valve

COD. CODE CÓD.	Pressure		lt/1'	US GPM	Ø	
	bar	PSI			mm	inches
<b>473 072</b>	20	290	190	50	25	1"
<b>473 070</b>			240	63	30	---
					32	1" 1/4

Caduta di pressione con valvola tutta aperta  
Full open valve pressure drop  
Perdita de caudal a válvula abierta

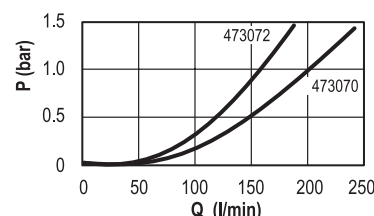

### Válvula de regulación proporcional manual

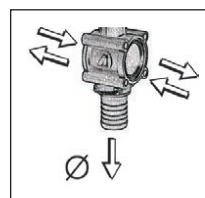

	A	B	C
mm	62	235	58
inches	2,5"	9,3"	2,3"

# FLANGE DI ACCOPPIAMENTO PER VALVOLE SERIE 873 VALVE ADAPTERS SERIES 873 BRIDAS DE ACOPLAMIENTO PARA VÁLVULAS SERIE 873

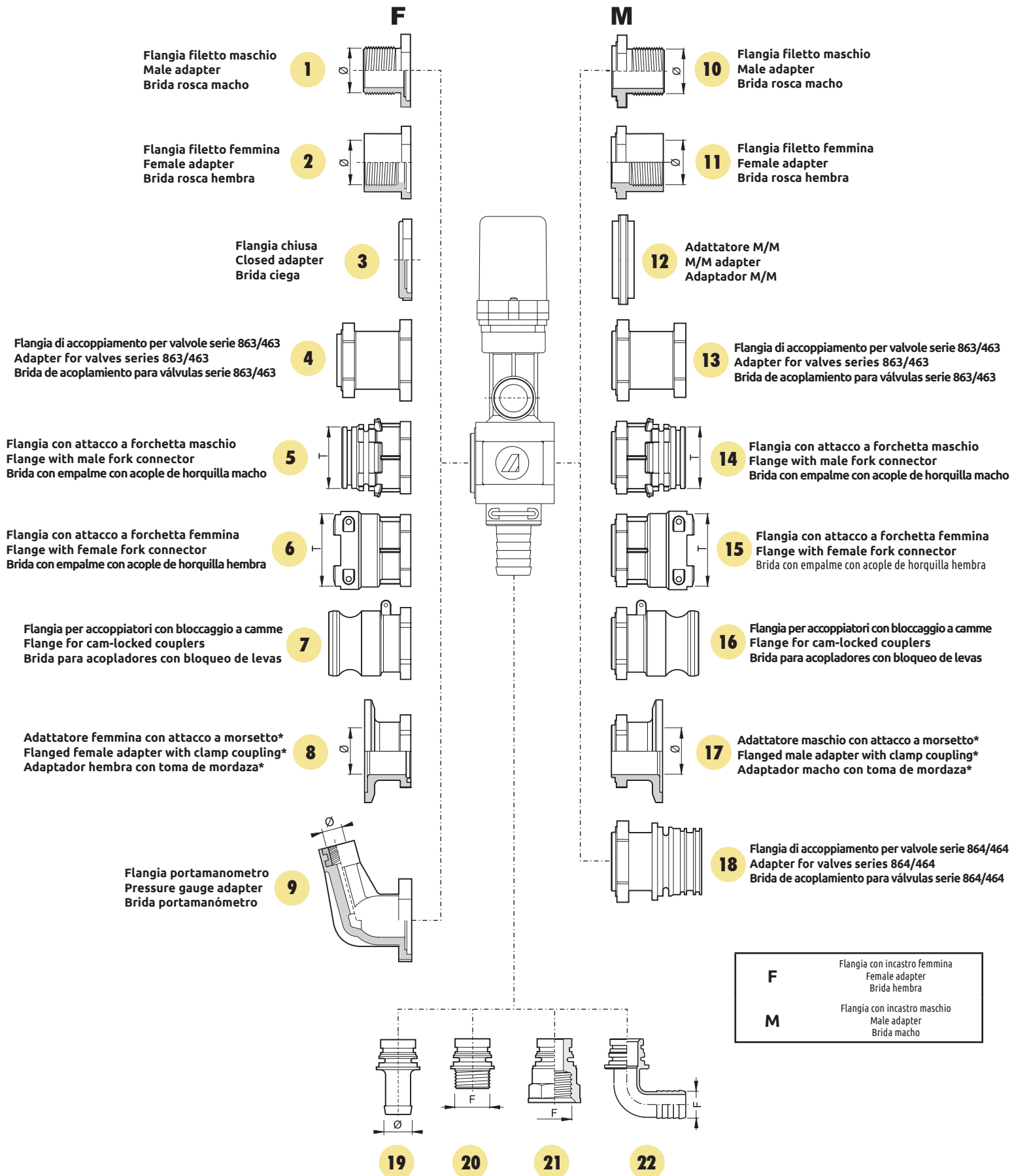

\*Compatibile con attacchi tipo Banjo®, Hypro® e Bee Valve®  
\*Compatible with Banjo®, Hypro® and Bee Valve® couplings  
\*Compatible con tomas tipo Banjo®, Hypro® y Bee Valve®

# FLANGE DI ACCOPPIAMENTO PER VALVOLE SERIE 873

## VALVE ADAPTERS SERIES 873

### BRIDAS DE ACOPLAMIENTO PARA VÁLVULAS SERIE 873

**1** Flangia filetto maschio  
Male adapter  
Brida rosca macho

COD. / CODE / CÓD.	Ø	MAT.
473 000.150	G1 1/4 (BSP)	Nylon
473 000.151	1 1/4 NPT	Nylon
473 000.160	G1 1/2 (BSP)	Nylon
473 000.161	1 1/2 NPT	Nylon
473 000.170	G2 (BSP)	Nylon
473 000.171	2 NPT	Nylon

**2** Flangia filetto femmina  
Female adapter  
Brida rosca hembra

COD. / CODE / CÓD.	Ø	MAT.
473 000.152	1 1/4 (BSP)	Nylon
473 000.153	1 1/4 NPT	Nylon
473 000.163	1 1/2 NPT	Nylon

**3** Flangia chiusa  
Closed adapter  
Brida ciega

COD. / CODE / CÓD.	MAT.
473 011.120	Nylon

**4** Flangia di accoppiamento per valvole serie 863/463  
Adapter for valves series 863/463  
Brida de acoplamiento para válvulas serie 863/463

COD. / CODE / CÓD.	MAT.
473 000.110	Nylon

**5** Flangia con attacco a forchetta maschio  
Flange with male fork connector  
Brida con empalme con acople de horquilla macho

COD. / CODE / CÓD.	T	MAT.	O'ring	
			EPDM	Viton®
473 000.156	T5	Nylon	G11063	G11063V
473 000.166	T6	Nylon	G11023	G11023V

**6** Flangia con attacco a forchetta femmina  
Flange with female fork connector  
Brida con empalme con acople de horquilla hembra

COD. / CODE / CÓD.	T	MAT.	Forchetta Fork Horquilla
473 000.157	T5	Nylon	010005
473 000.167	T6	Nylon	010006

**7** Flangia per accoppiatori con bloccaggio a camme  
Flange for cam-locked couplers  
Brida para acopladores con bloqueo de levas

COD. / CODE / CÓD.	Ø	MAT.
473 000.164	1" 1/2	Nylon
473 000.174	2"	Nylon

**8** Adattatore femmina con attacco a morsetto\*  
Flanged female adapter with clamp coupling\*  
Adaptador hembra con toma de mordaza\*

COD. / CODE / CÓD.	Ø	MAT.
473 000.175	2" FULL PORT	Nylon
473 000.165	2" STANDARD PORT	Nylon

**9** Flangia portamanometro  
Pressure gauge adapter  
Brida portamanómetro

COD. / CODE / CÓD.	Ø	MAT.
473 011.130	G 1/4 (BSP)	Nylon
473 011N.130	1/4" NPT	Nylon

**10** Flangia filetto maschio  
Male adapter  
Brida rosca macho

COD. / CODE / CÓD.	Ø	MAT.
473 000.050	G 1 1/4 (BSP)	Nylon
473 000.051	1 1/4 NPT	Nylon
473 000.060	G 1 1/2 (BSP)	Nylon
473 000.061	1 1/2 NPT	Nylon
473 000.070	G 2 (BSP)	Nylon
473 000.071	2 NPT	Nylon

**11** Flangia filetto femmina  
Female adapter  
Brida rosca hembra

COD. / CODE / CÓD.	Ø	MAT.
473 000.052	1 1/4 (BSP)	Nylon
473 000.053	1 1/4 NPT	Nylon
473 000.063	1 1/2 NPT	Nylon

**12** Adattatore M/M  
M/M adapter  
Adaptador M/M

COD. / CODE / CÓD.	MAT.
473 011.135	Nylon

**13** Flangia di accoppiamento per valvole serie 863/463  
Adapter for valves series 863/463  
Brida de acoplamiento para válvulas serie 863/463

COD. / CODE / CÓD.	MAT.
473 000.010	Nylon

**14** Flangia con attacco a forchetta maschio  
Flange with male fork connector  
Brida con empalme con acople de horquilla macho

COD. / CODE / CÓD.	T	MAT.	O'ring	
			EPDM	Viton®
473 000.056	T5	Nylon	G11063	G11063V
473 000.066	T6	Nylon	G11023	G11023V

**15** Flangia con attacco a forchetta femmina  
Flange with female fork connector  
Brida con empalme con acople de horquilla hembra

COD. / CODE / CÓD.	T	MAT.	Forchetta Fork Horquilla
473 000.067	T6	Nylon	010006

**16** Flangia per accoppiatori con bloccaggio a camme  
Flange for cam-locked couplers  
Brida para acopladores con bloqueo de levas

COD. / CODE / CÓD.	Ø	MAT.
473 000.064	1" 1/2	Nylon
473 000.074	2"	Nylon

**17** Adattatore maschio con attacco a morsetto\*  
Flanged male adapter with clamp coupling\*  
Adaptador macho con toma de mordaza\*

COD. / CODE / CÓD.	Ø	MAT.
473 000.075	2" FULL PORT	Nylon
473 000.065	2" STANDARD PORT	Nylon

**18** Flangia di accoppiamento per valvole serie 864/464  
Adapter for valves series 864/464  
Brida de acoplamiento para válvulas serie 864/464

COD. / CODE / CÓD.	MAT.
464 400.028	Nylon

**Raccordi per lo scarico - By-pass fittings - Racores para la descarga**

**19**

COD. / CODE / CÓD.	Ø	MAT.
473 001.A19C	19 mm	Nylon
473 001.A25C	25 mm	Nylon
473 001.A30C	30 mm	Nylon
473 001.A32C	32 mm	Nylon

**20**

COD. / CODE / CÓD.	F	MAT.
473 001.B30C	G3/4 (BSP)	Nylon
473 001.B40C	G1 (BSP)	Nylon
473 001.B50C	G1 1/4 (BSP)	Nylon

**21**

COD. / CODE / CÓD.	F	MAT.
473 001.B45NC	1" NPT	Nylon

**22**

COD. / CODE / CÓD.	Ø	MAT.
473 001.C25C	25 mm	Nylon

# VALVOLE DI REGOLAZIONE PROPORZIONALI PROPORTIONAL CONTROL VALVES VÁLVULAS DE REGULACION PROPORCIONAL

465

- Regola il flusso nei gruppi di distribuzione che effettuano trattamenti proporzionali ai giri motore (DPM)
- Struttura in Nylon® rinforzato con fibra di vetro
- Particolari interni in Delrin® e acciaio Inox AISI 303
- Guarnizioni in Viton®

- Adjusts the flow in the control units in which treatments vary in proportion with engine rpm (DPM)
- Fibreglass reinforced Nylon body
- Internal parts in Delrin® and AISI 303 stainless steel
- Gaskets made of Viton®

- Regula el flujo en los grupos de distribución que efectúan tratamientos proporcionales a las revoluciones del motor (DPM)
- Estructura de Nylon reforzado con fibra de vidrio
- Piezas interiores de Delrin® y acero Inox AISI 303
- Juntas de Viton®

## Valvola di regolazione proporzionale manuale attacco filettato



## Manual proportional control valve with threaded coupling

Caduta di pressione con valvola tutta aperta  
Pressure drop with fully open valve  
Caída de presión con válvula toda abierta

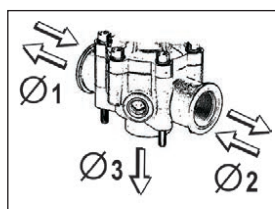
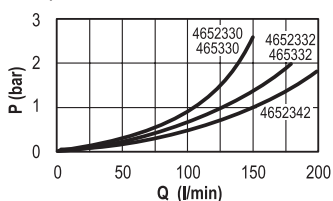

## Válvula de regulación proporcional manual con conexión enroscada

COD. CODE CÓD.	⌚		🔧 @ 1.5 bar @ 22 PSI		Ø1	Ø2	Ø3
	bar	PSI	lt/1'	US GPM	BSP	BSP	BSP
<b>465 2330</b>	20	290	125	33	G 3/4 F	G 3/4 F	G 3/4 F
<b>465 330</b>	50	725	125	33			
<b>465 2332</b>	20	290	160	42			
<b>465 332</b>	50	725	160	42	G 1 M	G 1 M	G 1 M
<b>465 2342</b>	20	290	180	48			



		A	B	C
B A C	mm	120	148	87
	inches	4,5"	6"	3,5"

## Valvola di regolazione proporzionale manuale attacco flangiato



## Manual proportional control valve with flanged coupling

Caduta di pressione con valvola tutta aperta  
Pressure drop with fully open valve  
Caída de presión con válvula toda abierta

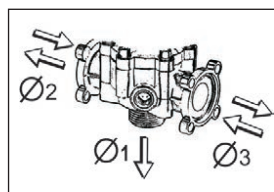
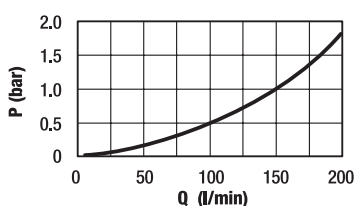

## Válvula de regulación proporcional manual con brida de conexión

COD. CODE CÓD.	⌚		🔧 @ 1.5 bar @ 22 PSI		Ø1	Ø2	Ø3
	bar	PSI	lt/1'	US GPM	BSP		
<b>465 2322</b>	20	290	180	48	G1 M	863	863



		A	B	C
B A C	mm	124	148	87
	inches	4,9"	6"	3,5"

F= femmina  
M= maschio

F= female  
M= male

F= hembra  
M= macho

Flange di accoppiamento e accessori per valvole modulari, pag. B-52

Adapters and accessories for modular valves, page B-52

Bridas de acoplamiento y accesorios para válvulas modulares, pág. B-52

- Bypassa il liquido in eccesso e consente di mantenere costante la pressione di linea
- Con membrana di separazione per una migliore sensibilità di regolazione
- Struttura in Nylon® rinforzato con fibra di vetro
- Particolari interni in Delrin® e acciaio Inox AISI 303
- Guarnizioni in Viton®

- By-passes the excess liquid and maintains constant line pressure
- Equipped with a separation diaphragm for enhanced control sensitivity
- Fibreglass reinforced Nylon body
- Internal parts in Delrin® and AISI 303 stainless steel
- Gaskets made of Viton®

- Deriva el líquido en exceso y permite mantener constante la presión de línea
- Con membrana de separación para mayor sensibilidad de regulación
- Estructura de Nylon reforzado con fibra de vidrio
- Piezas interiores de Delrin® y acero Inox AISI 303
- Juntas de Viton®

La clip estraibile permette di bloccare la valvola 475 alla pressione impostata.

The removable clip allows to block the valve 475 at the set pressure.

El clip extraíble permite bloquear la válvula 475 a la presión establecida.



### Valvola di regolazione massima pressione manuale a membrana, attacco filettato

### Manual diaphragm pressure relief control valve with threaded coupling

### Válvula de regulación máxima presión manual de membrana con conexión enroscada



COD. CODE CÓD.	⌚		🔌 @ 3 bar @ 40 PSI		Ø1	Ø2	Ø BY PASS
	bar	PSI	lt/1'	US GPM	BSP	BSP	BSP
475 533	30	435	200	53	G3/4 F	G3/4 F	G3/4 F
475 534	40	580					
475 535	50	725					

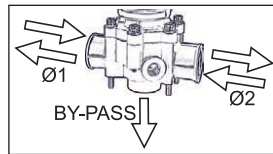

	A	B	C
mm	120	192	87
inches	4,5"	7,6"	3,5"

### Valvola di regolazione massima pressione manuale a membrana, attacco flangiato 863

### Manual diaphragm pressure relief control valve with 863 type flanged coupling

### Válvula de regulación máxima presión manual de membrana con brida de conexión 863



COD. CODE CÓD.	⌚		🔌 @ 3 bar @ 40 PSI		Ø BY PASS	Ø1 / Ø2
	bar	PSI	lt/1'	US GPM		
475 511	10	145	150	40	T5 F	863
475 512	20	290				
475 513	30	435	150	40	T5 F	863
475 514	40	580				

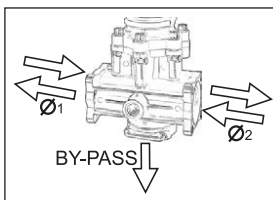

	A	B	C
mm	114	235	108
inches	4,5"	9,3"	4,3"

Accessori di completamento nel capitolo:  
Accessories available in chapter:  
Accesorios de terminación en el capítulo:

**FITTINGS**

F= femmina  
M= maschio  
T= attacco a forchetta

F= female  
M= male  
T= fork coupling

F= hembra  
M= macho  
T= toma de horquilla

Flange di accoppiamento e accessori per valvole modulari, pag. B-52

Adapters and accessories for modular valves, page B-52

Bridas de acoplamiento y accesorios para válvulas modulares, pág. B-52

# VALVOLE DI REGOLAZIONE MASSIMA PRESSIONE PRESSURE RELIEF CONTROL VALVES VÁLVULAS DE REGULACIÓN MÁXIMA PRESIÓN

# 865 - 875

- Bypassa il liquido in eccesso e consente di mantenere costante la pressione di linea
- Con membrana di separazione per una migliore sensibilità di regolazione
- Dimensioni compatte
- Struttura in Nylon® rinforzato con fibra di vetro
- Particolari interni in Delrin® e acciaio Inox AISI 303
- Guarnizioni in Viton®

- By-passes the excess liquid and maintains constant line pressure
- Equipped with a separation diaphragm for enhanced control sensitivity
- Compact sizes
- Fibreglass reinforced Nylon body
- Internal parts in Delrin® and AISI 303 stainless steel
- Gaskets made of Viton®

- Deriva el líquido en exceso y permite mantener constante la presión de línea
- Con membrana de separación para mayor sensibilidad de regulación
- Tamaños compactos
- Estructura de Nylon reforzado con fibra de vidrio
- Piezas interiores de Delrin® y acero Inox AISI 303
- Juntas de Viton®

## Valvola di regolazione massima pressione elettrica a membrana attacco filettato

## Electric diaphragm pressure relief control valve with threaded coupling

## Válvula de regulación máxima presión eléctrica de membrana con conexión enroscada



COD. CODE Cód.	Pressure		sec.	12 Vdc 3 A	Fittings	@ 3 bar @ 40 PSI	Ø1	Ø2	Ø BY PASS
	bar	PSI							
865 0633S	30	435	16	12 Vdc 3 A	200	53	G3/4 F	G3/4 F	G3/4 F
865 0634S	40	580							
865 0635S	50	725							

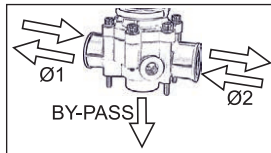

		A	B	C
mm	B	120	228	152
	A C	4,7"	9,0"	6,0"

## Valvola di regolazione massima pressione elettrica a membrana attacco flangiato 863

## Electric diaphragm pressure relief control valve with flanged coupling type 863

## Válvula de regulación máxima presión eléctrica de membrana con brida de conexión 863



COD. CODE Cód.	Pressure		sec.	12 Vdc 3 A	Fittings	@ 3 bar @ 40 PSI	Ø BY PASS	Ø1 / Ø2
	bar	PSI						
875 0612	20	290	16	12 Vdc 3 A	150	40	T5 F	863
875 0613	30	435						
875 0614	40	580						

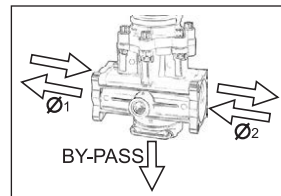

		A	B	C
mm	B	114	272	152
	A C	4,5"	10,7"	6,0"

Accessori di completamento nel capitolo:  
Accessories available in chapter:  
Accesorios de terminación en el capítulo:

### FITTINGS

Flange di accoppiamento e accessori per valvole modulari, pag. B-52

Adapters and accessories for modular valves, page B-52

Bridas de acoplamiento y accesorios para válvulas modulares, pág. B-52

Cavi e spine DIN a 3 fili  
3-wires DIN cables and plugs  
Cables y tomas DIN a 3 hilos

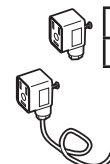

COD. / CODE / Cód.  
**ECS0033**

COD. / CODE / Cód.  
**8650900.140 (1.3 m)**

# 326 - 322

## FILTRI IN LINEA FLANGIATI FLANGED LINE FILTERS FILTROS EN LINEA BRIDADOS

### Filtri in linea serie 326

- Flangiabile direttamente alle valvole serie 871, 863 e 864
- Cartuccia Ø 58x210mm
- Corpo in polipropilene rinforzato
- Guarnizioni in EPDM (a richiesta in Viton®)
- Capacità filtrante 200÷280 l/min
- Versione autopulente con valvola di scarico



### Line filters series 326

- Can be connected directly to the valves series 871, 863 and 864
- Cartridge Ø 58x210mm
- Reinforced Polypropylene body
- EPDM gaskets (VITON® optional)
- Filtering capacity 200÷280 l/min
- Self-cleaning version with drain valve

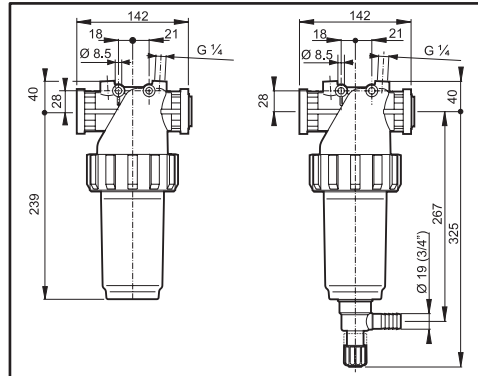

### Filtros en línea serie 326

- Puede acoplarse directamente a las válvulas serie 871, 863 y 864
- Cartucho Ø 58x210mm
- Cuerpo de polipropileno reforzado
- Juntas en EPDM (bajo demanda, en VITON®)
- Capacidad filtrante 200÷280 l/min
- Versión autolimpiante con válvula de descarga

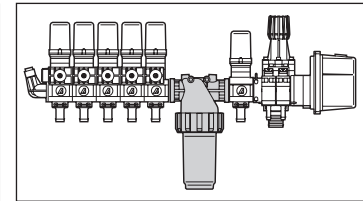

	Ricambio Spare part Repuesto
<b>COD. / CODE / CÓD.</b>	<b>Tipo / Type / Tipo</b>
<b>3262003.030</b>	Inox 50 mesh
<b>32620035.030</b>	Inox 80 mesh

			20 bar max 290 PSI max
			210 l/min @ 0,4 bar 55 US GPM @ 5 PSI
<b>STANDARD STANDARD ESTÁNDAR</b>	<b>AUTOPULENTE SELF-CLEANING AUTOLIMPIANTE</b>	<b>TIPO DI RETE SCREEN TYPE TIPO DE RED</b>	<b>AREA EFFETTIVA EFFECTIVE AREA ÁREA EFECTIVA</b>
<b>COD. / CODE / CÓD.</b>	<b>COD. / CODE / CÓD.</b>		<b>cm<sup>2</sup></b> <b>sq. inches</b>
<b>326 9013</b>	<b>326 9113</b>	Inox 50 mesh	106    16.4
<b>326 90135</b>	<b>326 91135</b>	Inox 80 mesh	97    15

### Filtri in linea serie 322

- Flangiabile direttamente alle valvole serie 871 e 863
- Cartuccia Ø 38x125mm
- Corpo in polipropilene rinforzato
- Guarnizioni in EPDM (a richiesta in Viton®)
- Capacità filtrante 150÷160 l/min
- Versione autopulente con valvola di scarico



### Line filters series 322

- Can be connected directly to the valves series 871 and 863
- Cartridge Ø 38x125mm
- Reinforced Polypropylene body
- EPDM gaskets (Viton® optional)
- Filtering capacity 150÷160 l/min
- Self-cleaning version with drain valve

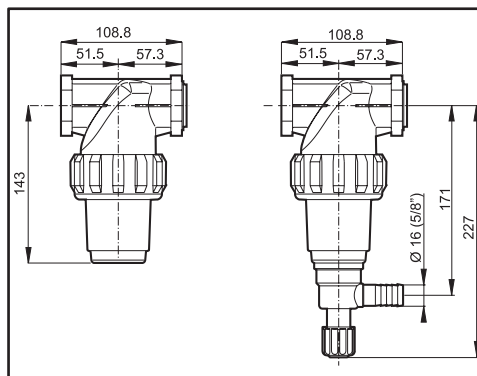

### Filtros en línea serie 322

- Puede acoplarse directamente a las válvulas serie 871 y 863
- Cartucho Ø 38x125mm
- Cuerpo de polipropileno reforzado
- Juntas en EPDM (bajo demanda, en Viton®)
- Capacidad filtrante 150÷160 l/min
- Versión autolimpiante con válvula de descarga

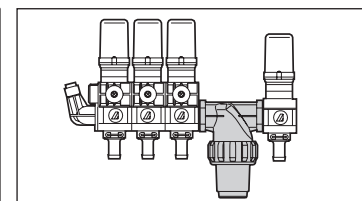

	Ricambio Spare part Repuesto
<b>COD. / CODE / CÓD.</b>	<b>Tipo / Type / Tipo</b>
<b>3232003.030</b>	Inox 50 mesh
<b>32320035.030</b>	Inox 80 mesh

			20 bar max 290 PSI max
			150 l/min @ 0,4 bar 40 US GPM @ 5 PSI
<b>STANDARD STANDARD ESTÁNDAR</b>	<b>AUTOPULENTE SELF-CLEANING AUTOLIMPIANTE</b>	<b>TIPO DI RETE SCREEN TYPE TIPO DE RED</b>	<b>AREA EFFETTIVA EFFECTIVE AREA ÁREA EFECTIVA</b>
<b>COD. / CODE / CÓD.</b>	<b>COD. / CODE / CÓD.</b>		<b>cm<sup>2</sup></b> <b>sq. inches</b>
<b>322 9013</b>	<b>322 9113</b>	Inox 50 mesh	38    5.9
<b>322 90135</b>	<b>322 91135</b>	Inox 80 mesh	34    5.3

**FILTRI IN LINEA FLANGIATI  
FLANGED LINE FILTERS  
FILTROS EN LINEA BRIDADOS**

**326**

**Filtri in linea serie 326**

- Flangiabile direttamente alle valvole serie 873
- Cartuccia Ø 58x210mm
- Corpo in polipropilene rinforzato
- Guarnizioni in EPDM (a richiesta in Viton®)
- Capacità filtrante 200÷280 l/min
- Versione autopulente con valvola di scarico



**Line filters series 326**

- Can be connected directly to the valves series 873
- Cartridge Ø 58x210mm
- Reinforced Polypropylene body
- EPDM gaskets (Viton® optional)
- Filtering capacity 200÷280 l/min
- Self-cleaning version with drain valve

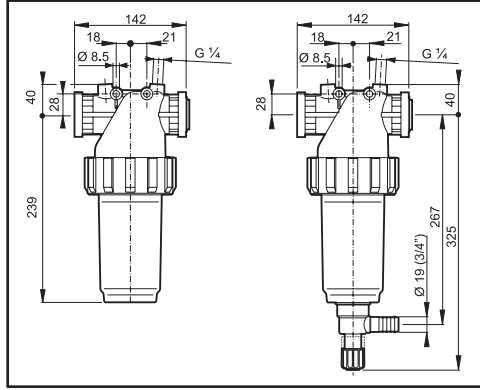

**Filtros en línea serie 326**

- Puede acoplarse directamente a las válvulas serie 873
- Cartucho Ø 58x210mm
- Cuerpo de polipropileno reforzado
- Juntas en EPDM (bajo demanda, en Viton®)
- Capacidad filtrante 200÷280 l/min
- Versión autolimpiante con válvula de descarga

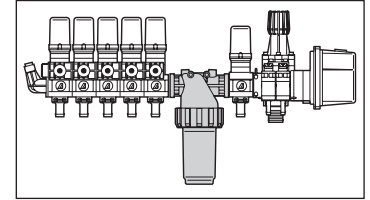

	Ricambio Spare part Repuesto
<b>COD. / CODE / CÓD.</b>	<b>Tipo / Type / Tipo</b>
<b>3262003.030</b>	Inox 50 mesh
<b>32620035.030</b>	Inox 80 mesh

			20 bar max 290 PSI max
			210 l/min @ 0,4 bar 55 US GPM @ 5 PSI
<b>STANDARD STANDARD ESTÁNDAR</b>	<b>AUTOPULENTE SELF-CLEANING AUTOLIMPIANTE</b>	<b>TIPO DI RETE SCREEN TYPE TIPO DE RED</b>	<b>AREA EFFETTIVA EFFECTIVE AREA ÁREA EFECTIVA</b>
<b>COD. / CODE / CÓD.</b>	<b>COD. / CODE / CÓD.</b>		<b>cm<sup>2</sup></b> <b>sq. inches</b>
<b>326 9003</b>	<b>326 9103</b>	Inox 50 mesh	106      16.4
<b>326 90035</b>	<b>326 91035</b>	Inox 80 mesh	97      15





# 863 T5

## GRUPPI VALVOLE VALVE UNITS GRUPOS VÁLVULAS

C113

**Gruppo elettrovalvole serie 863 con ritorni calibrati e attacco a forchetta T5**  
Composto dalle valvole 8630011 (n. 2÷7)

**Series 863 electrovalve set with metered by-pass and T5 fork connector**  
Consisting of 8630011 valves (no. 2 to 7)

**Grupo electroválvulas serie 863 con retornos calibrados y empalme con acople de horquilla T5**  
Compuesto por las válvulas 8630011 (Nº 2÷7)



Ingresso  
Inlet  
Entrada

**T5**  
fork  
coupling

COD. CODE CÓD.	Vie Ways Vias		
		bar	PSI
<b>863 01251</b>	2	20	290
<b>863 01351</b>	3		
<b>863 01451</b>	4		
<b>863 01551</b>	5		
<b>863 01651</b>	6		
<b>863 01751</b>	7		

### BY-PASS

**T4**  
fork  
coupling

Accessori di completamento per ritorni calibrati nel capitolo:  
Accessories for metered by-pass available in chapter:  
Accesorios para retornos calibrados en el capítulo:

### FITTINGS

**Gruppo elettrovalvole serie 863 ON/OFF con attacco a forchetta T5**  
Composto dalle valvole 8630001 (n. 2÷7)

**Series 863 ON-OFF electrovalve set with T5 fork connector**  
Consisting of 8630001 valves (no. 2 to 7)

**Grupo electroválvulas serie 863 ON/OFF con empalme con acople de horquilla T5**  
Compuesto por las válvulas 8630001 (Nº 2÷7)



Ingresso  
Inlet  
Entrada

**T5**  
fork  
coupling

COD. CODE CÓD.	Vie Ways Vias		
		bar	PSI
<b>863 00251</b>	2	20	290
<b>863 00351</b>	3		
<b>863 00451</b>	4		
<b>863 00551</b>	5		
<b>863 00651</b>	6		
<b>863 00751</b>	7		

Accessori di completamento nel capitolo:  
Accessories available in chapter:  
Accesorios de terminación en el capítulo:

### FITTINGS

Cavi e spine DIN a 3 fili  
3-wires DIN cables and plugs  
Cables y tomas DIN a 3 hilos

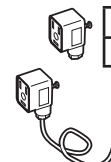

COD. / CODE / CÓD.  
**ECS0033**

COD. / CODE / CÓD.  
**8650900.140 (1.3 m)**

# VALVOLE SEZIONE DI BARRA BOOM SECTION VALVES VÁLVULAS SECCIÓN DE BARRA

# 863

## Valvola sezione di barra ad azionamento elettrico

- Struttura in Nylon® rinforzato con fibra di vetro
- Particolari interni in Delrin® e acciaio Inox AISI 303
- Guarnizioni in Viton®
- Fusibile interno resettabile (togliendo l'alimentazione per 20 secondi)
- Idonea al collegamento con i ritorni calibrati (solo cod. 8630011)

## Electric boom section valve

- Fibreglass-reinforced Nylon body
- Internal parts in Delrin® and AISI 303 stainless steel
- Gaskets made of Viton®
- Internal resettable fuse (disconnecting power for 20 seconds)
- Suitable for connection to metered by-pass (only code 8630011)

## Válvula sección de barra de accionamiento eléctrico

- Estructura de Nylon reforzado con fibra de vidrio
- Piezas interiores de Delrin® y acero Inox AISI 303
- Juntas de Viton®
- Fusible interior rearmable (parando l'alimentacion para 20 sec.)
- Idonea para la conexión con retornos calibrados (solo cod. 8630011)



8630001



8630011

COD. CODE Cód.	TIPO TYPE TIPO	Pressure		sec.	Electrical	Fittings	Ø OUT	
		bar	PSI				mm	inches
863 0001	ON/OFF	20	290	0,6	12 Vdc 0,5 A	(♦)	10-13-16	3/8"-1/2"-5/8"
		10	145				19-25	3/4"-1"
863 0011	BY-PASS	20	290	0,6	12 Vdc 0,5 A	(♦)	10-13-16	3/8"-1/2"-5/8"
		10	145				19-25	3/4"-1"



A	8630001			8630011		
	A	B	C	A	B	C
	mm	62	217	111	62	239
inches	2,5"	8,5"	4,5"	2,5"	9,5"	4,5"

- ♦ Portata a 0,5 bar (7 PSI) di caduta di pressione:
- ♦ Flow rate at 0,5 bar (7 PSI) pressure drop:
- ♦ Caudal a 0,5 bar (7 PSI) de caída de presión:

Ø OUT		Fittings		TYPE
mm	inches	lt/1'	US GPM	
10	3/8"	15	4	
13	1/2"	24	6	
16	5/8"	34	9	
19	3/4"	44	12	
25	1"	44	12	

Ø OUT		Fittings		TYPE
inches	lt/1'	US GPM		
G3/4 BSP	44	12		
3/4" NPT	44	12		
G3/4 BSP	44	12		

Specificare il diametro dei portagomma indicati in tabella.  
Specify the diameter of the hose fittings indicated in the table.  
Especificiquen el diámetro de los portamangueras indicados en la tabla.

## Valvola sezione di barra ad azionamento elettrico

- Struttura in Nylon® rinforzato con fibra di vetro
- Particolari interni in Delrin® e acciaio Inox AISI 303
- Guarnizioni in Viton®
- Fusibile interno resettabile (togliendo l'alimentazione per 20 secondi)
- Idonea al collegamento con i ritorni calibrati (solo cod. 8630011H)

## Electric boom section valve

- Fibreglass-reinforced Nylon body
- Internal parts in Delrin® and AISI 303 stainless steel
- Gaskets made of Viton®
- Internal resettable fuse (disconnecting power for 20 seconds)
- Suitable for connection to metered by-pass (only code 8630011H)

## Válvula sección de barra de accionamiento eléctrico

- Estructura de Nylon reforzado con fibra de vidrio
- Piezas interiores de Delrin® y acero Inox AISI 303
- Juntas de Viton®
- Fusible interior rearmable (parando l'alimentacion para 20 sec.)
- Idonea para la conexión con retornos calibrados (solo cod. 8630011H)



8630001H



8630011H

COD. CODE Cód.	TIPO TYPE TIPO	Pressure		sec.	Electrical	Fittings	@ 0.5 bar @ 7 PSI		Ø OUT BSP
		bar	PSI				lt/1'	US GPM	
863 0001H	ON/OFF	40	580	0,6	12 Vdc 0,7 A	35	9	G1/2	
863 0011H	BY-PASS								



A	8630001H			8630011H		
	A	B	C	A	B	C
	mm	62	200	111	62	222
inches	2,5"	8"	4,5"	2,5"	8,7"	4,5"

Flange di accoppiamento e accessori per valvole modulari, pag. B-52

Adapters and accessories for modular valves, page B-52

Bridas de acoplamiento y accesorios para válvulas modulares, pág. B-52

Cavi e spine DIN a 3 fili  
3-wires DIN cables and plugs  
Cables y tomas DIN a 3 hilos

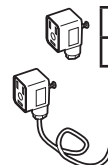

COD. / CODE / Cód.  
ECS0033

COD. / CODE / Cód.  
8650900.140 (1.3 m)

### Ritorni calibrati con valvola di bilanciamento graduata per valvole elettriche serie 863

I gruppi di comando elettrici ARAG vengono forniti con i nuovi ritorni calibrati graduati. Avendo sezioni di barra uguali è sufficiente effettuare la regolazione di una sola sezione e quindi posizionare gli altri regolatori sulla medesima tacca di riferimento della scala graduata per ottenere un'identica calibrazione.

- Estrema semplicità d'uso
- Regolazione della portata con scala graduata
- O'ring in Viton®
- Corpo in Nylon® rinforzato con fibra di vetro
- Forchetta di unione fra i moduli per garantire maggiore solidità
- Attacchi a forchetta con connessione **T4** per raccordi di completamento da ordinare separatamente

### Metered by-pass with graduated balancing valve for electric valves series 863

With the same boom sections it is enough regulate only one section and place the other regulators on the same notch of the graduated dial to obtain the same calibration.

- Easy to use
- Flow regulation with the graduated dial
- O'rings in Viton®
- Nylon reinforced with fibre glass body
- Union fork between the blocks to grant higher solidity
- Fork coupling with **T4** connection for the fittings

### Retornos calibrados con válvula de balance graduada para válvulas eléctricas serie 863

Teniendo secciones de barra iguales es suficiente efectuar la regulación de una sola sección y luego colocar los otros reguladores en la misma muesca de referencia de la escala graduada para obtener una idéntica calibración.

- Exrtema sencillez de empleo
- Regulación del caudal con escala graduada
- O'ring en Viton®
- Cuerpo de Nylon reforzado con fibra de vidrio
- Horquilla de unión entre los modulos para garantizar mayor solidez
- Enlaces de horquilla con conexión **T4** para racores para completar

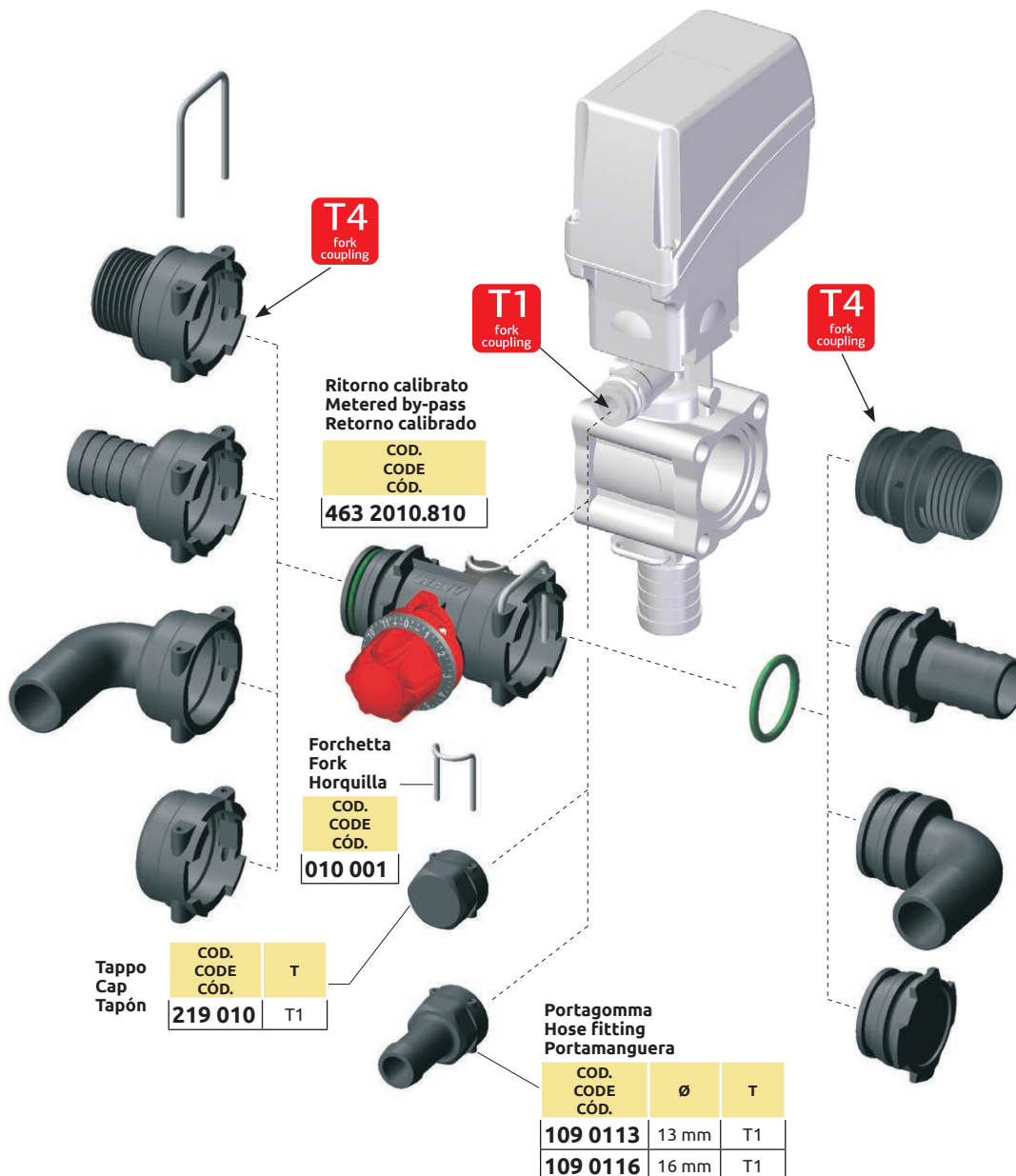

**T4**  
fork coupling

**T1**  
fork coupling

**T4**  
fork coupling

**Ritorno calibrato  
Metered by-pass  
Returno calibrado**  
COD.  
CODE  
CÓD.  
**463 2010.810**

**Forchetta  
Fork  
Horquilla**  
COD.  
CODE  
CÓD.  
**010 001**

**Tappo  
Cap  
Tapón**  
COD.  
CODE  
CÓD.    T  
**219 010**    T1

**Portagomma  
Hose fitting  
Portamanguera**  
COD.  
CODE  
CÓD.    Ø    T  
**109 0113**    13 mm    T1  
**109 0116**    16 mm    T1

**T1**  
fork coupling

**T4**  
fork coupling

**! IMPORTANTE! - IMPORTANT! - ¡IMPORTANTE!**  
Raccordi di completamento con attacco a forchetta da ordinare **SEPARATAMENTE** dal capitolo "FITTINGS"  
End fork fittings must be ordered **SEPARATELY** in the chapter "FITTINGS"  
Empalmes de terminación con toma de horquilla deben pedirse **POR SEPARADO** a la sección "FITTINGS"

**FLANGE DI ACCOPPIAMENTO PER VALVOLE SERIE 863**  
**VALVE ADAPTERS SERIES 863**  
**BRIDAS DE ACOPLAMIENTO PARA VÁLVULAS SERIE 863**

**F**

Flangia filetto maschio  
Male adapter  
Brida rosca macho

**1**

Flangia filetto femmina  
Female adapter  
Brida rosca hembra

**2**

Flangia chiusa  
Closed adapter  
Brida ciega

**3**

Flangia di accoppiamento per valvole serie 873/473  
Adapter for valves series 873/473  
Brida de acoplamiento para válvulas serie 873/473

**4**

Flangia con attacco a forchetta maschio  
Flange with male fork connector  
Brida con empalme con acople de horquilla macho

**5**

Adattatore F/F  
F/F adapter  
Adaptador H/H

**6**

Adattatore femmina con attacco a morsetto\*  
Flanged female adapter with clamp coupling\*  
Adaptador hembra con toma de mordaza\*

**7**

Flangia con attacco a forchetta femmina  
Flange with female fork connector  
Brida con empalme con acople de horquilla hembra

**8**

Flangia portamanometro  
Pressure gauge adapter  
Brida portamanómetro

**9**

Flangia portamanometro  
Pressure gauge adapter  
Brida portamanómetro

**10**

**M**

Flangia filetto maschio  
Male adapter  
Brida rosca macho

**11**

Flangia filetto femmina  
Female adapter  
Brida rosca hembra

**12**

Flangia chiusa  
Closed adapter  
Brida ciega

**13**

Flangia di accoppiamento per valvole serie 873/473  
Adapter for valves series 873/473  
Brida de acoplamiento para válvulas serie 873/473

**14**

Flangia con attacco a forchetta maschio  
Flange with male fork connector  
Brida con empalme con acople de horquilla macho

**15**

Adattatore M/M  
M/M adapter  
Adaptador M/M

**16**

Adattatore maschio con attacco a morsetto\*  
Flanged male adapter with clamp coupling\*  
Adaptador macho con toma de mordaza\*

**17**

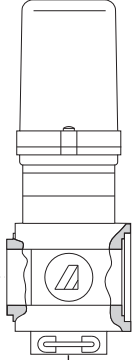

Valvole sezione di barra  
Boom section valves  
Válvulas seccion de barra

**18** **19** **20** **21**

Valvole sezione di barra (HS)  
Boom section valves (HS)  
Válvulas seccion de barra (HS)

**22**

Valvole proporzionali  
Proportional valves  
Válvulas proporcional

**23**

Valvole regolaz. pressione  
Pressure control valves  
Válvulas regulacion presión

**24**

<b>F</b>	Flangia con incastro femmina Female adapter Brida hembra
<b>M</b>	Flangia con incastro maschio Male adapter Brida macho

# FLANGE DI ACCOPPIAMENTO PER VALVOLE SERIE 863 VALVE ADAPTERS SERIES 863 BRIDAS DE ACOPLAMIENTO PARA VÁLVULAS SERIE 863

## 1 Flangia filetto maschio Male adapter Brida rosca macho

COD. / CODE / CÓD.	Ø	MAT. (*)
463 000.130	G 3/4	1
463 000H.130	G 3/4	2
463 000.131	3/4 NPT	1
463 000.140	G 1	1
463 000H.140	G 1	2
463 000.141	1 NPT	1
463 000.150	G 1 1/4	1
463 000.151	1 1/4 NPT	1

## 2 Flangia filetto femmina Female adapter Brida rosca hembra

COD. / CODE / CÓD.	Ø	MAT. (*)
463 000.132	G 3/4	1
463 000.133	3/4 NPT	1
463 000.142	G 1	1
463 000.143	1 NPT	1

## 3 Flangia chiusa Closed adapter Brida ciega

COD. / CODE / CÓD.	MAT. (*)
463 011.120	1
463 011H.120	2

## 4 Flangia di accoppiamento per valvole serie 873/473 Adapter for valves series 873/473 Brida de acoplamiento para válvulas serie 873/473

COD. / CODE / CÓD.	MAT. (*)
473 000.010	1

## 5 Flangia con attacco a forchetta maschio Flange with male fork connector Brida con empalme con acople de horquilla macho

COD. / CODE / CÓD.	T	MAT. (*)	O'ring	
			EPDM	Viton®
463 000.156	T5	1	G11063	G11063V

## 6 Adattatore F/F F/F adapter Adaptador H/H

COD. / CODE / CÓD.	MAT. (*)
463 011.140	1

## 7 Adattatore femmina con attacco a morsetto\* Flanged female adapter with clamp coupling\* Adaptador hembra con toma de mordaza\*

COD. / CODE / CÓD.	Ø	MAT. (*)
463 000.165	2" STANDARD PORT	1

## 8 Flangia con attacco a forchetta femmina Flange with female fork connector Brida con empalme con acople de horquilla hembra

COD. / CODE / CÓD.	T	MAT. (*)	Forchetta Fork Horquilla
463 000.157	T5	1	010005

## 9 Flangia portamanometro Pressure gauge adapter Brida portamanómetro

COD. / CODE / CÓD.	Ø	MAT. (*)
463 011.130	G 1/4	1
463 011N.130	1/4 NPT	1

## 10 Flangia portamanometro Pressure gauge adapter Brida portamanómetro

COD. / CODE / CÓD.	Ø	MAT. (*)
463 011H.130	G 1/4	2

## 11 Flangia filetto maschio Male adapter Brida rosca macho

COD. / CODE / CÓD.	Ø	MAT. (*)
463 000.030	G 3/4	1
463 000H.030	G 3/4	2
463 000.031	3/4 NPT	1
463 000.040	G 1	1
463 000H.040	G 1	2
463 000.041	1 NPT	1
463 000.050	G 1 1/4	1
463 000.051	1 1/4 NPT	1

## 12 Flangia filetto femmina Female adapter Brida rosca hembra

COD. / CODE / CÓD.	Ø	MAT. (*)
463 000.032	G 3/4	1
463 000.033	3/4 NPT	1
463 000.042	G 1	1
463 000.043	1 NPT	1

## 13 Flangia chiusa Closed adapter Brida ciega

COD. / CODE / CÓD.	MAT. (*)
463 011.110	1

## 14 Flangia di accoppiamento per valvole serie 873/473 Adapter for valves series 873/473 Brida de acoplamiento para válvulas serie 873/473

COD. / CODE / CÓD.	MAT. (*)
473 000.110	1

## 15 Flangia con attacco a forchetta maschio Flange with male fork connector Brida con empalme con acople de horquilla macho

COD. / CODE / CÓD.	T	MAT. (*)	O'ring	
			EPDM	Viton®
463 000.056	T5	1	G11063	G11063V

## 16 Adattatore M/M M/M adapter Adaptador M/M

COD. / CODE / CÓD.	MAT. (*)
463 011.135	1

## 17 Adattatore maschio con attacco a morsetto\* Flanged male adapter with clamp coupling\* Adaptador macho con toma de mordaza\*

COD. / CODE / CÓD.	Ø	MAT. (*)
463 000.065	2" STANDARD PORT	1

- (\*) materiale 1= Nylon®  
2= Ottone
- (\*) material 1= Nylon®  
2= Brass
- (\*) material 1= Nylon®  
2= Latón

### Raccordi per lo scarico - By-pass fittings - Racores para la descarga

18	COD. / CODE / CÓD.	Ø	MAT. (*)
	463 001.A10	10 mm	1
	463 001.A13	13 mm	1
	463 001.A16	16 mm	1
	463 001.A19	19 mm	1
	463 001.A25M	25 mm	1

19	COD. / CODE / CÓD.	Ø	MAT. (*)
	463 001.C13	13 mm	1

20	COD. / CODE / CÓD.	Ø	MAT. (*)
	463 001.B70	G 3/4	1
	463 001.B40M	G 1	1

21	COD. / CODE / CÓD.	Ø	MAT. (*)
	463 001.B75	G 3/4	1
	463 001.B75N	3/4 NPT	1

22	COD. / CODE / CÓD.	Ø	MAT. (*)
	463 001.B20 (*)	G 1/2	2
	463 001.B21M (*)	G 1/2	2

(\*) x Valvole manuali H / H manual valves / Válvulas manuales H  
(\*) x Valvole elettriche H / H electrical valves / Válvulas eléctricas H

23	COD. / CODE / CÓD.	Ø	MAT. (*)
	463 022.A13 (*)	13 mm	1
	463 001.A19 (*)	19 mm	1
	463 001.A25 (*)	25 mm	1

(\*) x 463072 / 8630026-S / 8630022-S

(\*) x 463070 / 8630020-S

(\*) x 463074 / 8630024-S

24	COD. / CODE / CÓD.	Valv.	Ø	MAT. (*)
	463 080.A19	463 080 463 081 463 083	19 mm	1
	463 082.A19	463 082	19 mm	1

\*Compatibile con attacchi tipo Banjo®, Hypro® e Bee Valve®  
\*Compatible with Banjo®, Hypro® and Bee Valve® couplings  
\*Compatible con tomas tipo Banjo®, Hypro® y Bee Valve®

**Collettori con valvola di scarico pressione**

- Consentono di azzerare la pressione residua del liquido che rimane intrappolato tra le valvole di sezione e valvola antigoccia, riducendo il gocciolamento.
- Azionamento a comando indotto dal motoriduttore della valvola
- Montaggio modulare con attacco a forchetta per facilitare l'installazione e l'ispezione
- Applicabili a tutti i gruppi ARAG serie 863 elettrici fino a 20 bar, sia nuovi che già in uso.

**Manifold with bleeder valve**

- Used to bleed off the residual pressure of the liquid that remains trapped between the section valves and check valve, thus reducing dripping.
- Induced control drive via valve geared motor
- Modular assembly with fork coupling for easier installation and inspection
- Can be fitted and retrofitted to all electric ARAG units series 863 up to 20 bar.

**Colectores con válvula de descarga presión**

- Permiten poner a cero la presión residual del líquido que permanece atrapado entre las válvulas de sección y la válvula antigoteo, reduciendo el goteo.
- Accionamiento con mando inducido por el motorreductor de la válvula
- Montaje modular con toma de horquilla para facilitar la instalación y la inspección
- Pueden aplicarse en todos los grupos eléctricos ARAG serie 863, tanto nuevos como ya en uso hasta 20 bar.

COD. CODE CÓD.	Per valvole For valves Para válvulas
<b>463 2000.300</b>	863

Raccordi di completamento con attacco a forchetta nel capitolo:  
 End fittings with fork coupling in chapter:  
 Empalmes de terminación con toma de horquilla en el capítulo:

**FITTINGS**



**T5**  
fork coupling

Maschio  
Male  
Macho

**T5**  
fork coupling

Femmina  
Female  
Hembra

bar  
**20**  
PSI



**T3**  
fork coupling

Maschio  
Male  
Macho

Forchette e O-ring sono già compresi nel collettore e non devono essere ordinati.

Forks and O-rings included in the manifold and therefore should not be ordered separately.

Horquillas y O-ring ya incluidos en el colector y no se deben pedir.

**Kit di assemblaggio**

Per completare il gruppo valvole ricordarsi di ordinare sempre una flangia tipo **M** ed una tipo **F** (pag. B-52).

**Assembly kit**

To complete the valve unit always remember to order an **M** type and **F** type adapter (page B-52).

**Kit de ensamblaje**

Para completar el grupo válvulas recuerden pedir siempre una brida tipo **M** y otra tipo **F** (pág. B-52)

n. valvole 463 n. valves 463 n. válvulas 463	Zincati (+) Galvanized (+) Cincado (+)	Acciaio Inox (**) Stainless Steel (**) Acero Inox (**)	L mm
	COD. CODE CÓD.	COD. CODE CÓD.	
1	463 000.910	463 900.910	90
2	463 000.920	463 900.920	150
3	463 000.930	463 900.930	207
4	463 000.940	463 900.940	264
5	463 000.950	463 900.950	321
6	463 000.960	463 900.960	378
7	463 000.970	463 900.970	436
8	463 000.980	463 900.980	493
9	463 000.990	463 900.990	550
10	463 000.9100	463 900.9100	610

F = Flangia con incastro femmina  
 M = Flangia con incastro maschio  
 F = Female adapter  
 M = Male adapter  
 F = Brida hembra  
 M = Brida macho

\* = Standard su gruppi manuali e per atomizzatori  
 \*\* = Standard su gruppi di comando elettrici  
 \* = Standard on manual & orchard control units  
 \*\* = Standard on electric control units

\* = Standard sobre log grupos manuales y para atomizadores  
 \*\* = Standard sobre los grupos de mando electrico

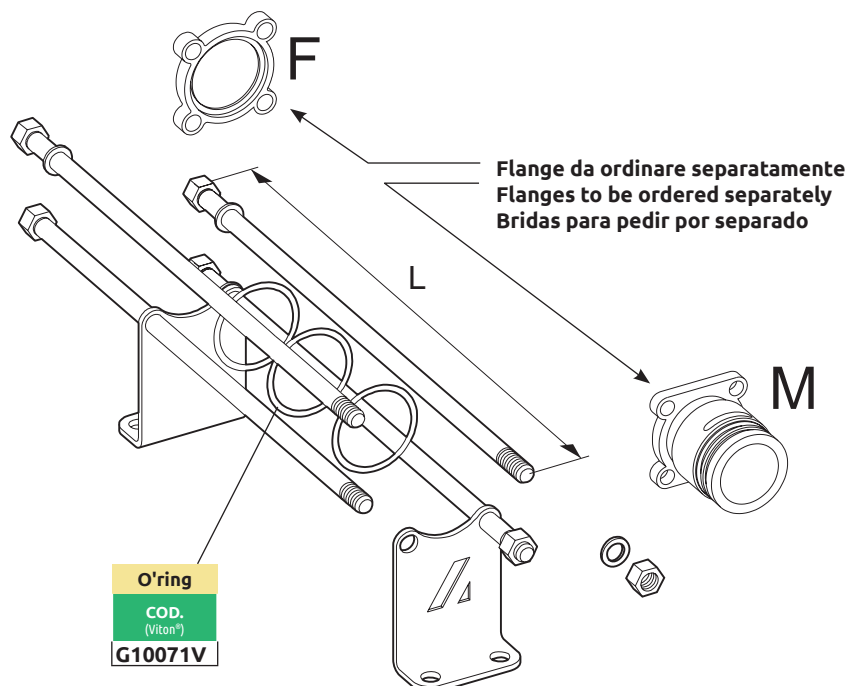

O'ring  
 COD.  
(Viton®)  
**G10071V**

Flange da ordinare separatamente  
 Flanges to be ordered separately  
 Bridas para pedir por separado

### Collettori di scarico modulari

Utilizzabili nei gruppi dove sia possibile unificare i ritorni verso la cisterna.

### Modular manifold

For use in units where all returns can be conveyed to the tank.

### Colectores de descarga modulares

Se utilizan en los grupos donde se pueden unificar los retornos hacia el tanque.

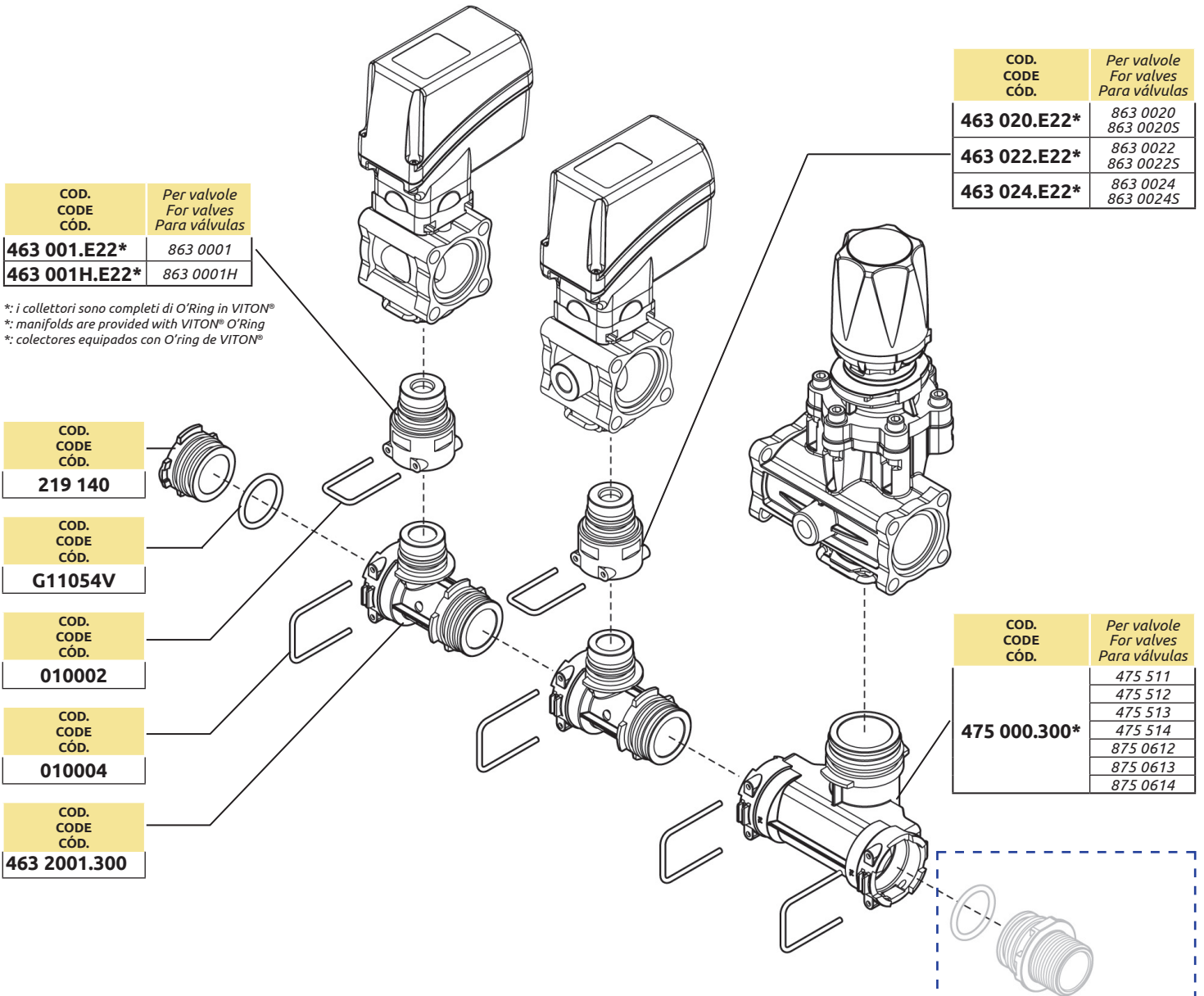

COD. CODE CÓD.	Per valvole For valves Para válvulas
<b>463 001.E22*</b>	863 0001
<b>463 001H.E22*</b>	863 0001H

\*: i collettori sono completi di O'Ring in VITON®  
\*: manifolds are provided with VITON® O'Ring  
\*: colectores equipados con O'ring de VITON®

COD. CODE CÓD.
<b>219 140</b>

COD. CODE CÓD.
<b>G11054V</b>

COD. CODE CÓD.
<b>010002</b>

COD. CODE CÓD.
<b>010004</b>

COD. CODE CÓD.
<b>463 2001.300</b>

COD. CODE CÓD.	Per valvole For valves Para válvulas
<b>463 020.E22*</b>	863 0020 863 0020S
<b>463 022.E22*</b>	863 0022 863 0022S
<b>463 024.E22*</b>	863 0024 863 0024S

COD. CODE CÓD.	Per valvole For valves Para válvulas
<b>475 000.300*</b>	475 511
	475 512
	475 513
	475 514
	875 0612
	875 0613 875 0614

**T4**  
fork  
coupling

Accessori di completamento nel capitolo:  
Accessories available in chapter:  
Accesorios de terminación en el capítulo:

**FITTINGS**

**ACCESSORI PER VALVOLE MODULARI**  
**ACCESSORIES FOR MODULAR VALVES**  
**ACCESORIOS PARA VÁLVULAS MODULARES**

# 863T-875

**Collettori di scarico modulari**

Utilizzabili con le valvole serie 863T con attacco a forchetta e 875.

**Modular drain manifolds**

Usable with 875 and 863T series valves with fork couplings.

**Colectores de descarga modulares**

Se utilizan con las válvulas serie 863T con unión de horquilla y 875.

**NEW**

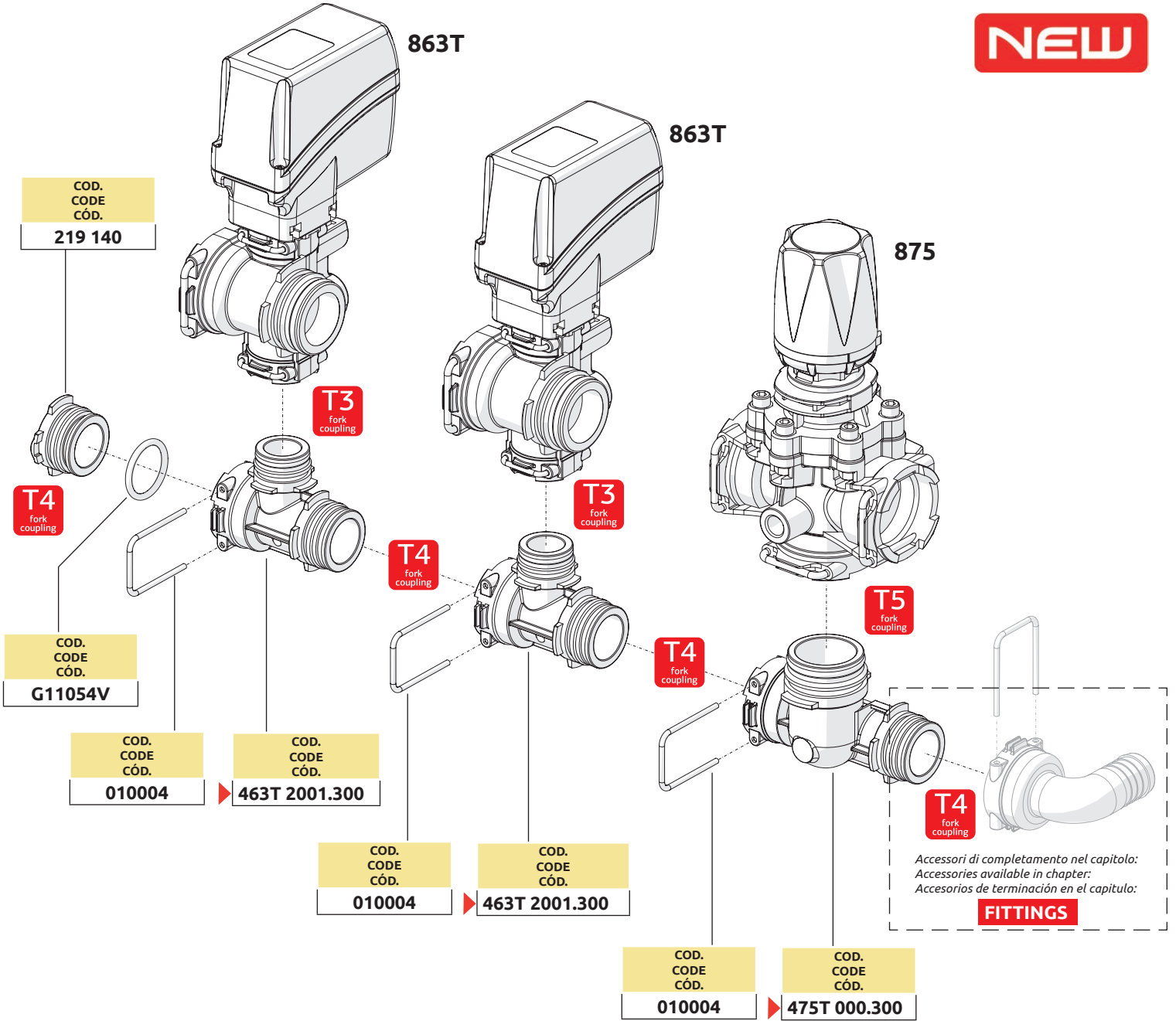



### Valvola sezione di barra ad azionamento manuale

- Struttura in Nylon® rinforzato con fibra di vetro
- Particolari interni in Delrin® e acciaio Inox AISI 303
- Guarnizioni in Viton®
- Idonea al collegamento con i ritorni calibrati (solo cod. 463061)

### Manually controlled boom section valve

- Fibreglass-reinforced Nylon body
- Internal parts in Delrin® and AISI 303 stainless steel
- Gaskets made of Viton®
- Suitable for connection to metered by-pass (only code 463061)

### Válvula sección de barra de accionamiento manual

- Estructura de Nylon reforzado con fibra de vidrio
- Piezas interiores de Delrin® y acero Inox AISI 303
- Juntas de Viton®
- Idonea para la conexión con retornos calibrados (solo cod. 463061)



COD. CODE CÓD.	TIPO TYPE TIPO	Pressure		Symbol	Ø OUT	
		bar	PSI		mm	inches
463 051	ON/OFF	20	290	⬇	10-13-16	3/8"-1/2"-5/8"
463 061	BY-PASS				19-25	3/4"-1"



A	463051			463061		
	B	C		A	B	C
	mm	62	214	100	62	236
inches	2,5"	8,4"	4"	2,5"	9,3"	4,5"

- ◆ Portata a 0,5 bar (7 PSI) di caduta di pressione:
- ◆ Flow rate at 0,5 bar (7 PSI) pressure drop:
- ◆ Caudal a 0,5 bar (7 PSI) de caída de presión:

Ø OUT		Pressure		TYPE
mm	inches	lt/1'	US GPM	
10	3/8"	15	4	
13	1/2"	24	6	
16	5/8"	34	9	
19	3/4"	44	12	
25	1"	44	12	

Ø OUT		Pressure		TYPE
inches	lt/1'	US GPM		
G3/4 BSP	44	12		
3/4" NPT	44	12		
G3/4 BSP	44	12		

Specificare il diametro dei portagomma indicati in tabella.  
Specify the diameter of the hose fittings indicated in the table.  
Especifiquen el diámetro de los portamangueras indicados en la tabla.

Flange di accoppiamento e accessori per valvole modulari, pag. B-52

Adapters and accessories for modular valves, page B-52

Bridas de acoplamiento y accesorios para válvulas modulares, pag. B-52

### Valvola sezione di barra ad azionamento manuale

- Struttura in Nylon® rinforzato con fibra di vetro
- Particolari interni in Delrin® e acciaio Inox AISI 303
- Guarnizioni in Viton®
- Idonea al collegamento con i ritorni calibrati (solo cod. 463061H)

### Manually controlled boom section valve

- Fibreglass-reinforced Nylon body
- Internal parts in Delrin® and AISI 303 stainless steel
- Gaskets made of Viton®
- Suitable for connection to metered by-pass (only code 463061H)

### Válvula sección de barra de accionamiento manual

- Estructura de Nylon reforzado con fibra de vidrio
- Piezas interiores de Delrin® y acero Inox AISI 303
- Juntas de Viton®
- Idonea para la conexión con retornos calibrados (solo cod. 463061H)



COD. CODE CÓD.	TIPO TYPE TIPO	Pressure		Symbol	Flow Rate @ 0.5 bar @ 7 PSI		Ø OUT
		bar	PSI		lt/1'	US GPM	
463 051H	ON/OFF	40	580	⬇	35	9	G1/2
463 061H	BY-PASS						



A	463051H			463061H		
	B	C		A	B	C
	mm	62	247	211	62	269
inches	2,5"	9,7"	8,3"	2,5"	10,6"	8,3"

Flange di accoppiamento e accessori per valvole modulari, pag. B-52

Adapters and accessories for modular valves, page B-52

Bridas de acoplamiento y accesorios para válvulas modulares, pag. B-52

# GRUPPI DI COMANDO PER DISERBO CONTROL UNITS FOR CROP SPRAYERS GRUPOS DE MANDO PARA PULVERIZADORES

# 464 - 471

## Gruppo manuale proporzionale

Composto dalle valvole:  
464202 + 463061 (n. 4÷6) + 463074

## Proportional manual unit

Valves in the assembly:  
464202 + 463061(n. 4÷6) + 463074

## Grupo manual proporcional

Con válvulas:  
464202 + 463061(n. 4÷6) + 463074

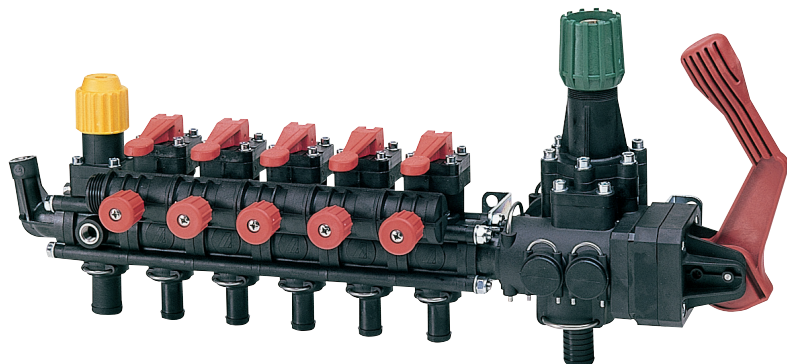

COD. CODE CÓD.	Vie Ways Vias	⌚		⚙️	
		bar	PSI	lt/1'	US GPM
<b>464 240</b>	4	20	290	200	53
<b>464 250</b>	5	20	290	250	66
<b>464 260</b>	6	20	290	250	66

## Gruppo manuale proporzionale

Composto dalle valvole:  
463070 + 463061 (n. 2÷5) + 471202

## Proportional manual unit

Valves in the assembly:  
463070 + 463061(n. 2÷5) + 471202

## Grupo manual proporcional

Con válvulas:  
463070 + 463061(n. 2÷5) + 471202

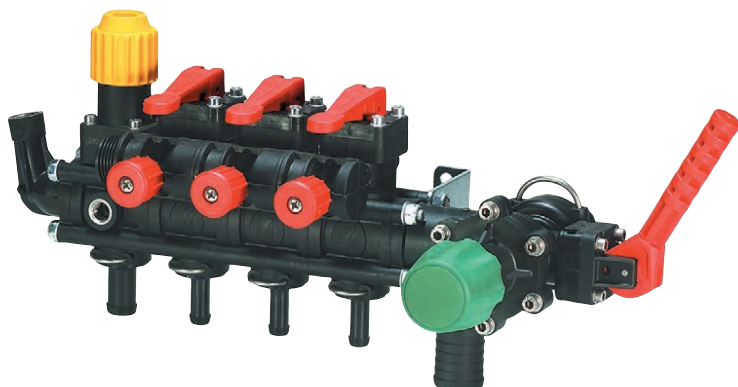

COD. CODE CÓD.	Vie Ways Vias	⌚		⚙️	
		bar	PSI	lt/1'	US GPM
<b>471 220 2B0</b>	2	20	290	120	32
<b>471 230 2B0</b>	3	20	290	140	37
<b>471 240 2B0</b>	4	20	290	160	42
<b>471 250 2B0</b>	5	20	290	180	48

## Gruppo manuale a pressione costante

Composto dalle valvole:  
471202 + 463051 (n. 2÷5)

## Constant pressure manual unit

Valves in the assembly:  
471202 + 463051(n. 2÷5)

## Grupo manual de presión constante

Con válvulas:  
471202 + 463051(n. 2÷5)

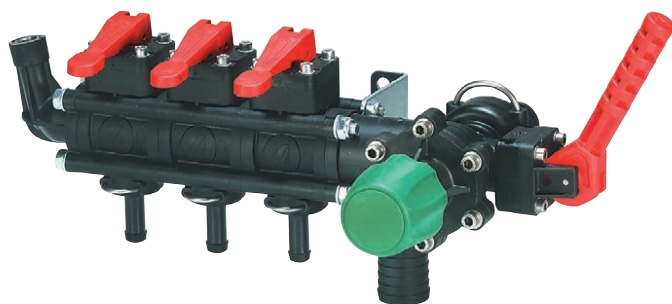

COD. CODE CÓD.	Vie Ways Vias	⌚		⚙️	
		bar	PSI	lt/1'	US GPM
<b>471 120 200</b>	2	20	290	120	32
<b>471 130 200</b>	3	20	290	140	37
<b>471 140 200</b>	4	20	290	160	42
<b>471 150 200</b>	5	20	290	180	48

Specificare nell'ordine il diametro dei raccordi portagomma di entrata e uscita.

When ordering specify the diameter of the inlet and outlet hose fittings.

Especifiquen en el pedido el diámetro de los racores portamangueras de entrada y salida mando.

# 461-465-471

## GRUPPI DI COMANDO PER DISERBO CONTROL UNITS FOR CROP SPRAYERS GRUPOS DE MANDO PARA PULVERIZADORES

### Gruppo manuale a pressione costante

Composto dalle valvole:  
471202 + 461020 (o 461030 o 461040 o 461050  
o 461060)

### Constant pressure manual unit

Valves in the assembly:  
471202 + 461020 (or 461030 or 461040 or  
461050 or 461060)

### Grupo manual de presión constante

Con válvulas:  
471202 + 461020 (o 461030 o 461040 o 461050  
o 461060)



COD. CODE CÓD.	Vie Ways Vias	bar		US GPM	
		bar	PSI	lt/1'	US GPM
471 020 200	2	20	290	100	26
471 030 200	3	20	290	120	32
471 040 200	4	20	290	140	37
471 050 200	5	20	290	160	42
471 060 200	6	20	290	180	48



### Gruppo manuale a pressione costante

Composto dalle valvole:  
465522 + 461020 (o 461030)

### Constant pressure manual unit

Valves in the assembly:  
465522 + 461020 (or 461030)

### Grupo manual de presión constante

Con válvulas:  
465522 + 461020 (o 461030)



COD. CODE CÓD.	Vie Ways Vias	bar		US GPM	
		bar	PSI	lt/1'	US GPM
465 0112	2	20	290	100	26
465 0113	3	20	290	120	32



### Gruppo valvole manuali con ingresso flangiato oppure filettato da G 1

### Manual valve unit with flanged inlet or 1" BSP threaded inlet

### Grupo válvulas manuales con entrada bridada o roscada G 1

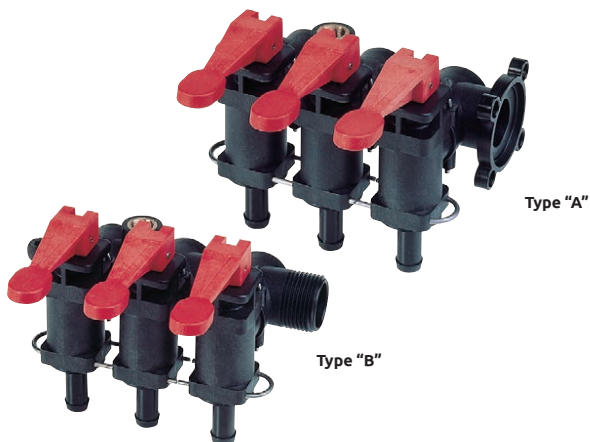

COD. CODE CÓD.		Vie Ways Vias	bar	
Type "A"	Type "B"		bar	PSI
461 020	461 021	2	20	290
461 030	461 031	3		
461 040	461 041	4		
461 050	461 051	5		
461 060	461 061	6		



Specificare nell'ordine il diametro dei raccordi portagomma di entrata e uscita.

When ordering specify the diameter of the inlet and outlet hose fittings.

Especifiquen en el pedido el diámetro de los racores portamangueras de entrada y salida mando.

# GRUPPI DI COMANDO CON VALVOLE A SFERA CONTROL UNITS WITH BALL VALVES GRUPOS DE MANDO CON VÁLVULAS DE BOLA

853

Gruppi di comando derivati dalle valvole a sfera della serie 853.

Identici nelle caratteristiche, sono dotati di attacchi rapidi, modulari, a forchetta che consentono una configurazione elastica e adattabile ad ogni necessità.

- Alta portata (290 lt. per singola sezione)
- Pressione di funzionamento 12 bar
- Nuovo sistema modulare con attacco a forchetta
- Assemblaggio rapido, semplice e compatto
- Perno di rotazione in acciaio Inox
- Sfera in acciaio Inox AISI 316 ricoperta in Teflon®
- Sedi di tenuta delle sfera in Teflon®
- O'ring interni in VITON®
- Tiranti di fissaggio flange in acciaio Inox, protetti dal corpo valvola
- Azionamento elettrico 12 Vdc
- Ogni tipo di configurazione a richiesta

Control units derived from ball valves of the 853 series.

With identical features, these valves have modular, fork-type quick couplings, enabling a flexible configuration suited to any need.

- High flow rate (290 l per single section)
- Operating pressure 12 bar
- New modular system with fork coupling
- Quick assembly, simple and compact
- Stainless steel rotating pin
- AISI 316 stainless steel ball coated with Teflon®
- Ball seats in Teflon®
- Internal O-rings in VITON®
- Flange fastening stays in stainless steel, protected by valve body
- Electric 12 Vdc operation
- Any type of configuration on request

Grupos de mando derivados de las válvulas de bola de la serie 853.

Idénticos en sus características, han sido dotados de acoples rápidos, modulares, de horquilla que permiten una configuración elástica y adaptable para cada necesidad.

- Alto caudal (290 lt. para cada sección)
- Presión de funcionamiento 12 bar
- Nuevo sistema modular con acople de horquilla
- Ensamblado rápido, simple y compacto
- Perno de rotación de acero Inox
- Bola de acero Inox AISI 316 recubierta de Teflón®
- Alojamiento herméticos de la bola de Teflón®
- O'ring internos de VITON®
- Tirantes de fijación bridas de acero Inox, protegidos del cuerpo de la válvula
- Accionamiento eléctrico 12 Vdc
- Cada tipo de configuración, a pedido

## Sistema di fissaggio integrato brevettato

- Realizzato direttamente sul corpo senza l'apporto di inserti
- Compensa errori di allineamento sulle forature
- Fissaggio con viti a testa esagonale M8 (o 5/16 UN)

## Patented integrated fixing system

- Directly on the body; no inserts
- Self adjustment in case of misalignment
- Fixing through hexagonal head screws M8 (or 5/16 UN)

## Sistema de bloqueo integrado patentado

- Realizado directamente sobre el cuerpo sin utilizar insertos
- Compensa los errores de alineamiento de los agujeros
- Sujeción con tornillos de cabeza hexagonal M8 (or 5/16 UN)

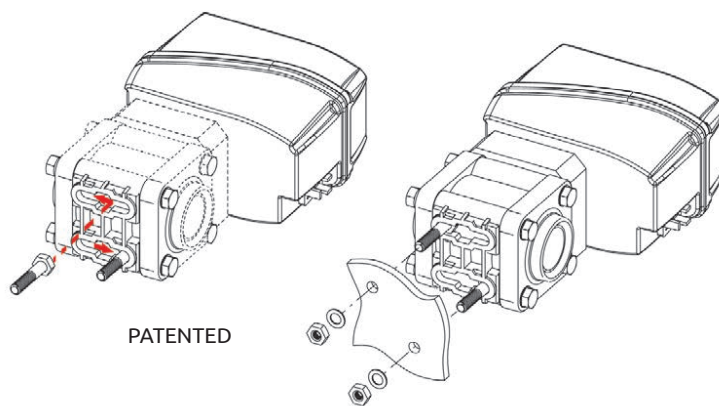

Valvole serie 853 con comando a 3 fili, compatibili con comando a 2 fili. Schemi e connessioni nel capitolo:

All valves series 853 are 3-wire control valves compatible with 2-wire controls. Diagrams and connections in chapter:

Todas las válvulas serie 853 son de mando con 3 cables, compatibles con mandos de 2 cables. Esquemas y conexiones en el capítulo:

**BALL VALVES**

Cavi e spine DIN a 3 fili  
3-wires DIN cables and plugs  
Cables y tomas DIN a 3 hilos

COD. / CODE / CÓD.

8650900.140 (1.3 m)

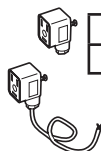

COD. / CODE / CÓD.

ECS0033

### Valvola di comando generale, elettrica a sfera

Valvola elettrica a sfera 3 vie, di comando generale, flangiata per gruppi serie 863 e 873.

### Electric main control ball valve

3-way electrical main ball valve, flanged for units Series 863 and 873.

### Válvula de bola eléctrica de mando general

Válvula de bola eléctrica 3 vías de mando general, bridada para grupos serie 863 y 873.



COD. CODE CÓD.	Pressure		ON-OFF	12 Vdc 3 A	lt/1'	@ 1.5 bar @ 22 PSI US GPM	Ø IN	Ø OUT	Ø BY-PASS
	bar	PSI							
853 K14SB6	12	174	1,4 sec.	12 Vdc 3 A	480	127	T6	473*	T6
853 K14SA6								463*	



		A	B	C
A	mm	165	228	155
	inches	6.5"	9"	6"



Accessori di completamento nel capitolo:  
Accessories available in chapter:  
Accesorios de terminación en el capítulo:

### FITTINGS

Valvola con comando a 3 fili compatibile con comandi a 2 fili. Schemi e connessioni a pag. B-3.  
3-wire control valve compatible with 2-wire controls. Refer to page B-3 for diagrams and connections.  
Válvula de mando de 3 cables compatible con mandos de dos cables. Esquemas y conexiones a pag. B-3.

Altre valvole serie 853 nel capitolo:  
Other valves series 853 in chapter:  
Otras valvulas serie 853 en el capítulo:

### BALL VALVES

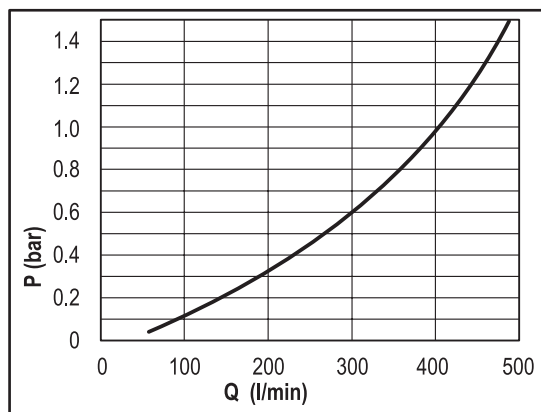
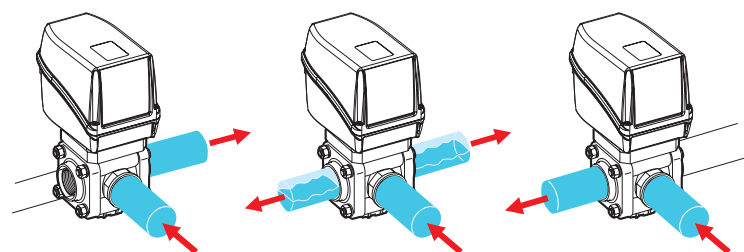

\*: anello adattatore e O'ring da ordinare separatamente  
\*: adapter ring and O-ring ordered separately  
\*: anillo adaptador y O'ring para pedir por separado



Adattatore M/M M/M adapter Adaptador M/M	O'ring	Tipo Type Tipo
COD. / CODE / CÓD.	COD. / CODE / CÓD.	
463 011.135	G10071V	863
473 011.135	454236.080V	873

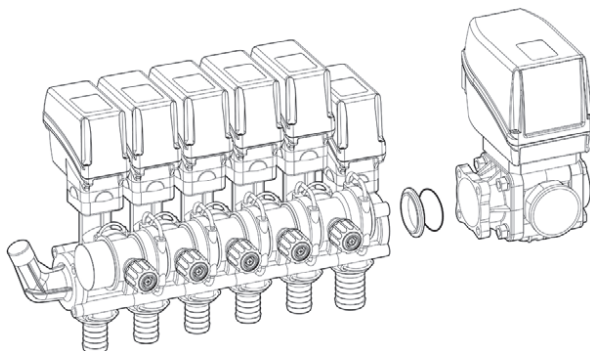

Cavi e spine DIN a 3 fili  
3-wires DIN cables and plugs  
Cables y tomas DIN a 3 hilos



COD. / CODE / CÓD.  
ECS0033

COD. / CODE / CÓD.  
8650900.140 (1.3 m)

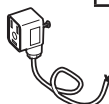

**GRUPPO DI COMANDO GENERALE CON VALVOLE A SFERA**  
**MAIN CONTROL UNIT WITH BALL VALVES**  
**GRUPO DE MANDO GENERAL CON VÁLVULAS DE BOLA**

**853 T6**

**Gruppi di comando generale**

Gruppo di comando composto da:

- Valvola generale a 3 vie (azion. 1,4 sec.) cod. 853L14S66J
- Valvola di regolazione proporzionale (azion. 7 sec.) cod. 853K740CCA
- Collettori di scarico

**Main control units**

Control unit composed of:

- 3-way main valve (switching time: 1.4 sec.) cod. 853814S66J
- Proportional control valve (switching time: 7 sec.) cod. 853K740CCA
- Drain manifolds

**Grupos de mando general**

Grupo de mando formado por:

- Válvula general de tres vías (accion. 1,4 seg.) cod. 853814S66J
- Válvula de regulación proporcional (accion. 7 seg.) cod. 853K740CCA
- Colectores de descarga





**T6**  
fork coupling

T6 = 1 1/4" = (Full port)  
1 1/2" = (Standard port)



**AISI 316 BALL**

Designed for use with BRAVO and DELTA computers

 COD. CODE CÓD.					Ø IN	Ø OUT	Ø BY-PASS
	bar	PSI	lt/1'	US GPM			
853 GA7C00A	12	174	480	127	T6	T6	T6

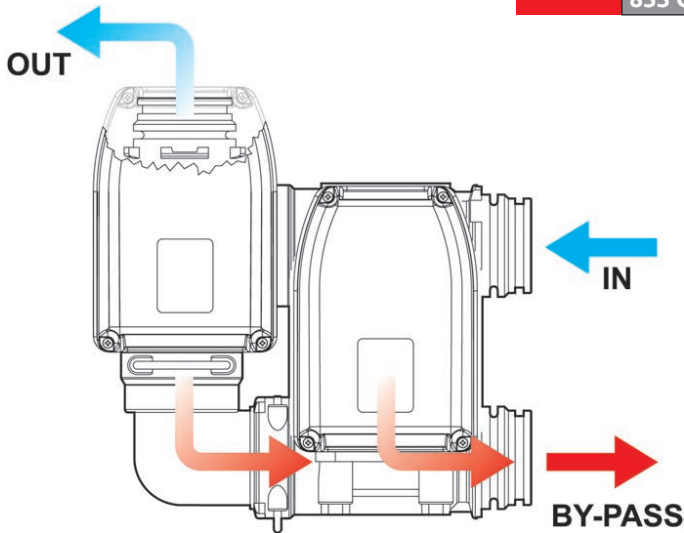

Altre valvole serie 853 nel capitolo:  
 Other valves series 853 in chapter:  
 Otras valvulas serie 853 en el capitulo:

**BALL VALVES**

Accessori di completamento nel capitolo:  
 Accessories available in chapter:  
 Accesorios de terminación en el capitulo:

**FITTINGS**

Cavi e spine DIN a 3 fili  
 3-wires DIN cables and plugs  
 Cables y tomas DIN a 3 hilos



COD. / CODE / CÓD.  
**ECS0033**

COD. / CODE / CÓD.  
**8650900.140 (1.3 m)**

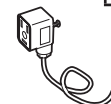

# GRUPPI DI COMANDO CON VALVOLE A SFERA CONTROL UNITS WITH BALL VALVES GRUPOS DE MANDO CON VÁLVULAS DE BOLA

## Gruppo valvole di sezione

Composto dalle valvole: 853K04SC6 (n. 3÷5)

## Section valve group

Valves in the assembly: 853K04SC6 (n. 3÷5)

## Grupo válvulas de sección

Con válvulas: 853K04SC6 (n. 3÷5)



COD. CODE CÓD.	Vie Ways Vías	⌚		⚙️		Ø IN	Ø OUT
		bar	PSI	lt/1'	US GPM		
<b>853 GA0030A</b>	3	12	174	290	77	T6	T6
<b>853 GA0050A</b>	5	12	174	290	77		

\* Portata indicativa riferita alla singola sezione alla pressione di 0,5 bar (7 PSI).  
La portata può variare a seconda del numero di sezioni presenti nel gruppo.  
\* Approximate flow rate referred to single section at 0.5 bar (7 PSI) pressure.  
Rate can vary according to the number of sections in the unit.  
\* Caudal indicativo referido a cada sección a la presión de 0,5 bar (7 PSI).  
El caudal puede variar de acuerdo al número de secciones que se encuentren en el grupo.

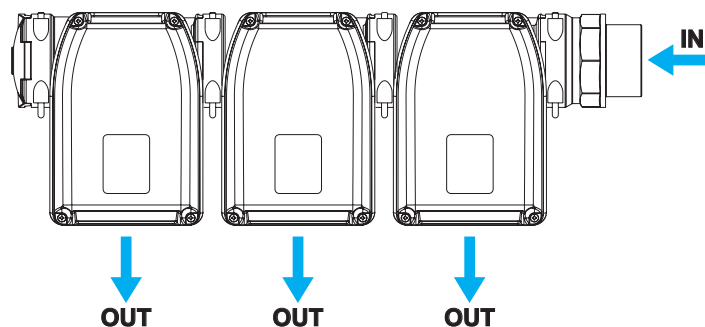

T6 = 1 1/4" = (Full port)  
1 1/2" = (Standard port)



Altre valvole serie 853 nel capitolo:  
Other valves series 853 in chapter:  
Otras válvulas serie 853 en el capítulo:

**BALL VALVES**

## Valvola sezione di barra

## Boom section valve

## Válvula sección de barra



COD. CODE CÓD.	⌚		⌚	⚡	⚙️	@ 0.5 bar @ 7 PSI	Ø IN	Ø OUT
	bar	PSI	sec.	lt/1'	US GPM			
<b>853 K04SC6</b>	12	174	1,4	12 Vdc 3 A	290	77	T6	T6

T6 = 1 1/4" = (Full port)  
1 1/2" = (Standard port)



	A	B	C
mm	146	228	150
inches	5,7"	9"	5,9"



Altre valvole serie 853 nel capitolo:  
Other valves series 853 in chapter:  
Otras válvulas serie 853 en el capítulo:

**BALL VALVES**

VALVOLE DI REGOLAZIONE PROPORZIONALE  
 PROPORTIONAL CONTROL VALVES  
 VÁLVULAS DE REGULACION PROPORCIONAL

853



Designed for use with BRAVO and DELTA computers



COD. CODE CÓD.	Pressure		ON-OFF	12 Vdc 1 A	Flow		F
	bar	PSI			lt/1'	US GPM	
853 K74A55A	12	174	7 sec.	12 Vdc 1 A	390	105	G1 1/4" F*
853 K75A66A	10	145			720	190	G1 1/2" F*
853 K76A77A	8	120			900	240	G2" F



\*: 1 1/4" = (Full port)  
 1 1/2" = (Full port)  
 2" = (Full port)

A B C	1 1/4"			1 1/2"			2"			
	A	B	C	A	B	C	A	B	C	
	mm	105	228	102	128	244	102	150	271	102
	inches	4.1"	9"	4"	5"	9.6"	4"	5.9"	10.7"	4"



Designed for use with BRAVO and DELTA computers



COD. CODE CÓD.	Pressure		ON-OFF	12 Vdc 1 A	Flow		F
	bar	PSI			lt/1'	US GPM	
853 K74S55A	12	174	7 sec.	12 Vdc 1 A	390	105	T5
853 K75S66A	10	145			720	190	T6
853 K76S77A	8	120			900	240	T7



Accessori di completamento nel capitolo:  
 Accessories available in chapter:  
 Accesorios de terminación en el capítulo:

**FITTINGS**

A B C	T5			T6			T7			
	A	B	C	A	B	C	A	B	C	
	mm	165	228	102	169	244	102	203	271	102
	inches	6.5"	9"	4"	6.7"	9.6"	4"	8"	10.7"	4"



Designed for use with BRAVO and DELTA computers

COD. CODE CÓD.	Pressure		ON-OFF	12 Vdc 1 A	Flow		F*
	bar	PSI			lt/1'	US GPM	
853 K75L66A	10	145	7 sec.	12 Vdc 1 A	720	190	2" Std. port
853 K76L77A	8	120			900	240	2" Full port



Accessori di completamento nel capitolo:  
 Accessories available in chapter:  
 Accesorios de terminación en el capítulo:

**FITTINGS**

A B C	2" Std. port			2" Full port			
	A	B	C	A	B	C	
	mm	133	230	102	170	248	102
	inches	5.2"	9"	4"	6.7"	9.8"	4"

\*: Compatibile con attacchi tipo Banjo®, Hypro® e Bee Valve®.  
 Suitable for use with Banjo®, Hypro® and Bee Valve® connections.  
 Compatible con las conexiones tipo Banjo®, Hypro® y Bee Valve®.

Altre valvole serie 853 nel capitolo:  
 Other valves series 853 in chapter:  
 Otras valvulas serie 853 en el capítulo:

**BALL VALVES**

Cavi e spine DIN a 3 fili  
 3-wires DIN cables and plugs  
 Cables y tomas DIN a 3 hilos

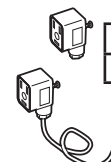

COD. / CODE / CÓD.  
**ECS0033**

COD. / CODE / CÓD.  
**8650900.140 (1.3 m)**





Designed for use with  
BRAVO and DELTA  
computers



COD. CODE CÓD.	bar	PSI	sec.	12 Vdc 3 A	@ 0.5 bar @ 7 PSI	Ø IN	Ø OUT
853 K745C6A	12	174	7	12 Vdc 3 A	290	77	T6 T6



Accessori di completamento nel capitolo:  
Accessories available in chapter:  
Accesorios de terminación en el capítulo:

**FITTINGS**

	A	B	C
mm	146	228	150
inches	5,7"	9"	5,9"

### Valvola di regolazione proporzionale elettrica con sfera sagomata

- La sfera sagomata permette una regolazione più accurata e lineare anche alle basse portate.
- Sfera e perno di rotazione in acciaio Inox AISI 316.
- Sedi di tenuta delle sfere in TEFLON®
- O'ring interni in Viton®
- Tiranti di fissaggio flange in acciaio Inox, protetti dal corpo valvola.
- Disponibile con filetto femmina o con attacco a forchetta.

### Electric proportional control valve with shaped ball

- The shaped ball allows a more accurate and linear regulation also at a low flowrate.
- Ball and rotation pin in AISI 316 STAINLESS steel.
- Ball sealing seats in TEFLON®
- Internal O-rings in Viton®
- Flange fixing bolts in STAINLESS steel, protected by the valve body.
- Available with female thread or fork coupling.

### Válvula de regulación proporcional eléctrica con bola perfilada

- La bola perfilada permite una regulación más precisa y lineal, incluso con bajos caudales.
- Bola y perno de rotación de acero INOXIDABLE AISI 316.
- Alojamiento de estanqueidad de las bolas de TEFLON®
- Juntas tóricas internas de Viton®
- Tirantes de fijación bridas de acero INOXIDABLE, protegidos por el cuerpo válvula.
- Disponible con rosca hembra o toma de horquilla.



AISI 316  
BALL

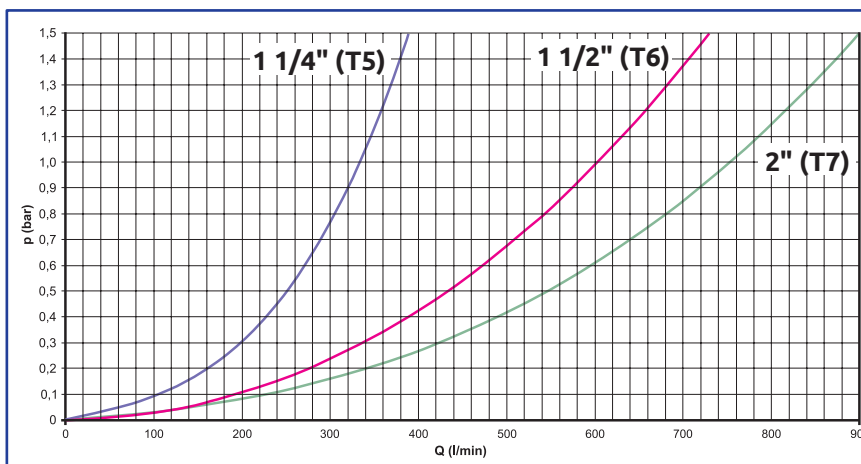

Caduta di pressione con valvola tutta aperta (nel senso di flusso indicato nello schema a fondo pagina).

Pressure drop with completely open valve (in the direction of the flow indicated in the diagram at the bottom of the page).

Caída de presión con válvula toda abierta (en la dirección de flujo indicada en el esquema al fondo de la página).

La particolare forma della sfera permette una regolazione molto accurata del flusso (vedi grafico a fianco) rispetto alle classiche valvole con foro rotondo. Il flusso risulta così più lineare e preciso anche alle basse portate.

The particular ball shape allows a much more accurate flow regulation (see diagram on the side) than the classic valves with round hole. The flow is more linear and precise also at a low flowrate.

La particular forma de la bola permite una regulación muy precisa del flujo (ver gráfico de al lado) respecto a las clásicas válvulas con orificio redondo. De esta manera, el flujo resulta más lineal y preciso incluso con bajos caudales.

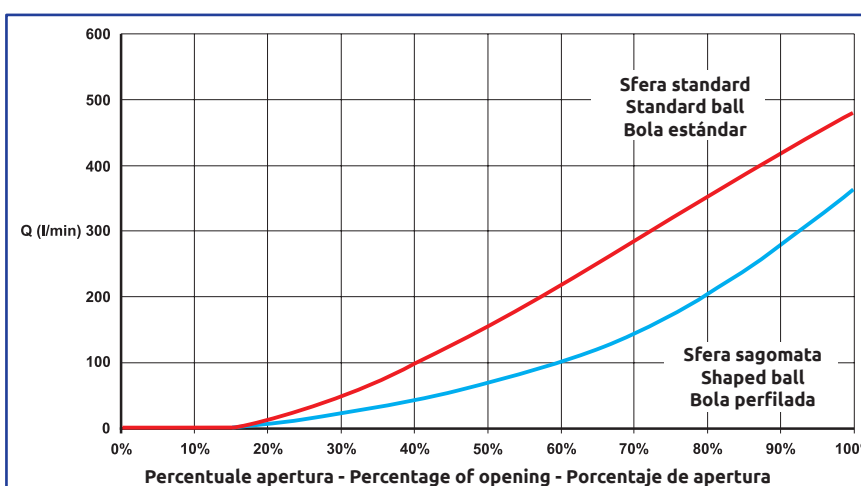

Regolazione della portata: confronto fra sfere con foro standard e sagomato. Grafico riferito alle valvole con sfera DN 32.

Flowrate regulation: comparison between balls with standard hole and shaped balls. Diagram referred to valves with DN 32.

Regulación del caudal: comparación entre bolas con orificio estándar y perfilado. Gráfico referido a las válvulas con bola DN 32.

# GRUPPI DI COMANDO COMPATTI PER ATOMIZZATORI COMPACT CONTROL UNITS FOR ORCHARD SPRAYERS GRUPOS DE MANDO COMPACTOS PARA ATOMIZADORES

# 881

I gruppi di comando serie 881 per atomizzatore si distinguono per le ridotte dimensioni, frutto di un'eccezionale ingegnerizzazione di prodotto che ha permesso di realizzare un componente realmente innovativo. Realizzati con materiali ad elevata resistenza, garantiscono una notevole portata anche ad alte pressioni di utilizzo.

- Ingombri ridotti del 50% rispetto ad un gruppo standard equivalente
- Facile installazione
- Filtro integrato autopulente
- Particolari interni realizzati con materiali anticorrosione e antiusura
- Adatti a pompe con portata fino a 150 l/min
- Massima pressione di lavoro 40 bar (580 PSI)

Control units series 881 for sprayers are very compact and innovative as they are manufactured relying on latest technology. Made of high resistant materials, they bear high flow rates even at high operating pressures.

- Half the space required if compared with equivalent standard units.
- Easy to be installed
- Fitted with integrated self-cleaning filter
- Featuring corrosion-resistant and wear-resistant inner parts.
- Suitable for pumps having a flow rate up to 150 l/min.
- Max. operating pressure: 40 bar (580 PSI)

Los grupos de mando serie 881 para atomizador se distinguen por las reducidas dimensiones, resultado de un excepcional trabajo de ingeniería que ha permitido realizar un componente realmente innovador. Realizados con materiales de elevada resistencia, garantizan un importante caudal incluso en altas presiones de uso.

- Dimensiones reducidas un 50% respecto a un grupo estándar equivalente
- Fácil instalación
- Filtro integrado autolimpiante
- Componentes internos realizados con materiales anti-corrosión y anti-desgaste
- Adecuados para bombas con caudal hasta 150 l/min.
- Máxima presión de trabajo 40 bar (580 PSI)

## PATENTED

Ritorni calibrati con attacco a forchetta.  
Metered by-pass with fork connection.  
Retornos calibrados con toma de horquilla.

Blocco valvola generale, valvola proporzionale, valvola di massima pressione e filtro inglobati in un solo corpo.  
Main valve block; proportional valve, max. pressure valve and filter built into a single body.  
Bloque válvula general, válvula proporcional, válvula de máxima presión y filtro en un solo cuerpo.

Assemblaggio con valvole di sezione standard serie 863.  
Assembly with standard section valves series 863.  
Ensamblado con válvulas de sección estándar serie 863.

Filtro frontale con sistema di pulizia automatica.  
Front self-cleaning filter.  
Filtro delantero con sistema de limpieza automática.

Attacco supplementare non filtrato con attacco G 1/2 F per spurgo o ausiliari.  
Non-filtered additional G 1/2 F connector for drainage or auxiliary devices.  
Toma suplementaria no filtrada con toma G 1/2 H para purga o auxiliares.

Valvola di massima pressione ad alta portata con gruppo membrana di elevata sensibilità.  
High flow rate max. pressure valve with highly sensitive membrane unit.  
Válvula de máxima presión de alto caudal con grupo membrana de elevada sensibilidad.

Attacco del connettore interno al motore: minore ingombro e connettore più protetto.  
Connector base is inside the motor to save space in the installation, and to make the unit more reliable.  
Ataque del conector al interior del motorreductor para ocupar menor espacio de instalación y asegurar mayor fiabilidad del equipo.

Raccordo di ingresso in ottone G 3/4 M con attacco a forchetta.  
Inlet G 3/4 M brass fork connection.  
Acople de ingreso de latón G 3/4 M con toma de horquilla.

Unico raccordo di scarico per il ritorno in cisterna Ø 25 mm.  
Single Ø 25 mm drain connector for tank return.  
Único acople de descarga para el retorno a la cisterna Ø 25 mm.

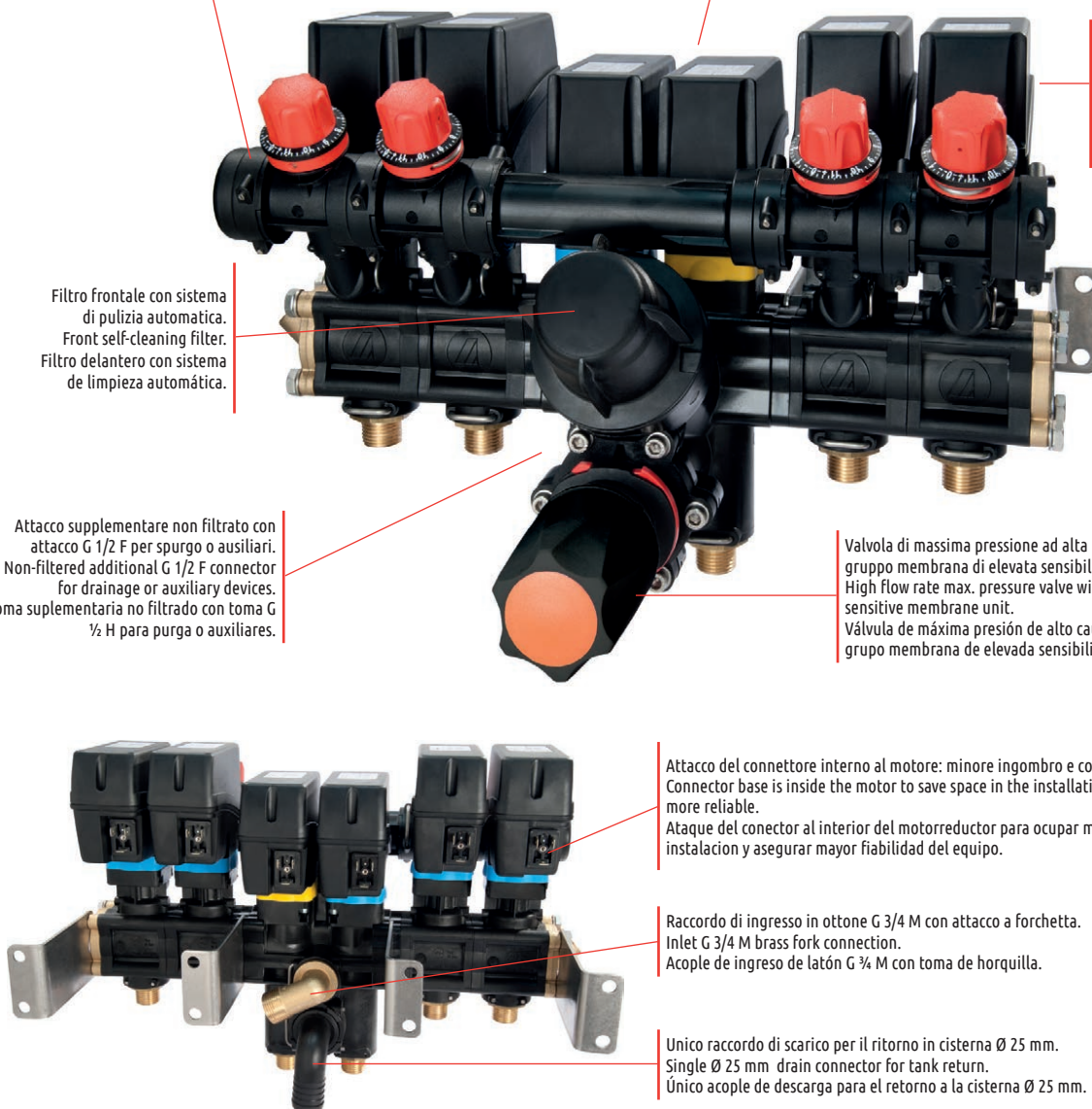

Gruppo composto da valvola di massima pressione serie 875, filtro 50 mesh serie 345 e 2 o 4 valvole di sezione ON/OFF equivalenti a tipo 8630001H\*.

Unit consisting of a max. pressure valve series 875 + 50 mesh filter series 345 and 2 or 4 ON/OFF section valves equivalents to type 8630001H\*.

Grupo compuesto por válvula de máxima presión serie 875 + filtro 50 mesh serie 345 y 2 o 4 válvulas de sección ON/OFF equivalentes al tipo 8630001H\*.



COD. CODE CÓD.	Vie Ways Vias	🕒		🔧	
		bar	PSI	lt/1'	US GPM
881 412202	2	20	290	150	40
881 414202		40	580		
881 412214	4	20	290		
881 414214		40	580		

\*: nei gruppi di comando compatti serie 881 vengono integrate nel corpo, valvole con le stesse caratteristiche tecniche dei codici descritti.

\*: in the 881 series compact control units, valves with the same technical characteristics of the codes described are integrated into the body.

\*: en los grupos de mando compactos serie 881 vienen integradas en el cuerpo, válvulas con las mismas características técnicas que los códigos descritos.

### Gruppo di comando PROPORZIONALE per atomizzatore

Gruppo composto da valvola di massima pressione serie 875, filtro 50 mesh serie 345 e 2 valvole di sezione con ritorni calibrati equivalenti a tipo 8630011H\*.

### PROPORTIONAL control unit for orchard sprayer

Assembly composed of 875 series maximum pressure valve, 345 series 50 mesh filter and 2 section valves with metered by-pass equivalent to type 8630011H\*.

### Grupo de mando PROPORCIONAL para atomizador

Grupo formado por válvula de máxima presión serie 875, filtro 50 mesh serie 345 y 2 válvulas de sección con retornos calibrados equivalentes de tipo 8630011H\*.

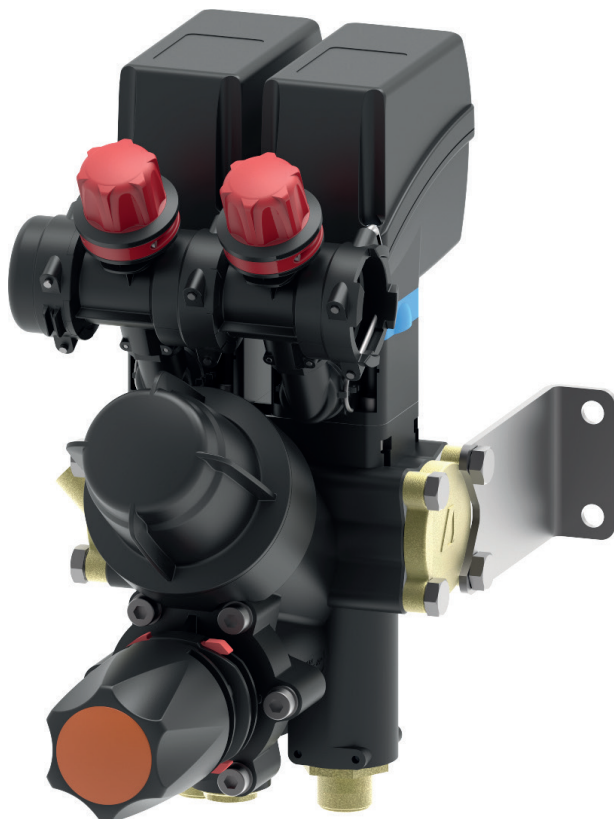

**NEW**



COD. CODE CÓD.	Vie Ways Vias	🕒		🔧	
		bar	PSI	lt/1'	US GPM
▶ 881 E12202	2	20	290	150	40
▶ 881 E14202	2	40	580	150	40

\*: nei gruppi di comando compatti serie 881 vengono integrate nel corpo, valvole con le stesse caratteristiche tecniche dei codici descritti.

\*: in the 881 series compact control units, valves with the same technical characteristics of the codes described are integrated into the body.

\*: en los grupos de mando compactos serie 881 vienen integradas en el cuerpo, válvulas con las mismas características técnicas que los códigos descritos.

# GRUPPI DI COMANDO COMPATTI PER ATOMIZZATORI COMPACT CONTROL UNITS FOR ORCHARD SPRAYERS GRUPOS DE MANDO COMPACTOS PARA ATOMIZADORES

881

Gruppo composto da modulo base (Valvola generale equivalente tipo 8630001H, valvola proporzionale equivalente tipo 8630020, valvola di massima pressione serie 875, filtro 50 mesh serie 345) e 2 o 4 valvole di sezione con ritorni calibrati equivalenti tipo 8630011H\*.

Assembly composed of basic module (Main valve equivalent to type 8630001H, proportional valve equivalent to type 8630020, 875 series maximum pressure valve, 345 series 50 mesh filter) and 2 or 4 section valves with metered by-pass equivalent to type 8630011H\*.

Grupo formado por módulo base (Válvula general equivalente tipo 8630001H, válvula proporcional equivalente tipo 8630020, válvula de máxima presión serie 875, filtro 50 mesh serie 345) y 2 o 4 válvulas de sección con retorno calibrado equivalentes tipo 8630011H\*.



COD. CODE CÓD.	Vie Ways Vias	⌚		⚙️	
		bar	PSI	lt/1'	US GPM
881 212242	2	20	290	150	40
881 214242		40	580		
881 212244	4	20	290		
881 214244		40	580		



**T4**  
fork  
coupling

Accessori di completamento nel capitolo:  
Accessories available in chapter:  
Accesorios de terminación en el capítulo:

**FITTINGS**

Gruppo composto da modulo base (Valvola generale equivalente tipo 8630001H, valvola proporzionale equivalente tipo 8630020, valvola di massima pressione serie 875, filtro 50 mesh serie 345), flussometro ORION 2 (cod. 46211A20000) e 2 o 4 valvole di sezione con ritorni calibrati equivalenti tipo 8630011H\*.

Assembly composed of basic module (Main valve equivalent to type 8630001H, proportional valve equivalent to type 8630020, 875 series maximum pressure valve, 345 series 50 mesh filter), ORION 2 flowmeter (code 46211A20000) and 2 or 4 section valves with metered by-pass equivalent to 8630011H\*.

Grupo formado por módulo base (Válvula general equivalente tipo 8630001H, válvula proporcional equivalente tipo 8630020, válvula de máxima presión serie 875, filtro 50 mesh serie 345), caudalímetro ORION 2 (cód. 46211A20000) y 2 o 4 válvulas de sección con retorno calibrado equivalentes tipo 8630011H\*.



ORION 2

COD. CODE CÓD.	Vie Ways Vias	⌚		⚙️		Flussometro Flowmeter Caudalímetro
		bar	PSI	lt/1'	US GPM	
881 B12252B	2	20	290	150	40	ORION2
881 B14252B		40	580			
881 B12254B	4	20	290			
881 B14254B		40	580			



**T4**  
fork  
coupling

Accessori di completamento nel capitolo:  
Accessories available in chapter:  
Accesorios de terminación en el capítulo:

**FITTINGS**

- Elettrovalvole con ritorni calibrati per distribuzione costante
  - Elettrovalvola di regolazione proporzionale
  - Elettrovalvola di scarico
  - Nuova valvola di massima pressione a membrana serie 475
  - Flange in ottone
- Composto dalle valvole: 8630011H (n. 2÷4) + 8630001H + 8630020 + 475514 (40 bar) / 475512 (20 bar) + 34520030 (per gruppi con filtro)

- Electrovalves with metered by-pass for constant distribution
  - Proportional control electrovalve
  - By-pass electrovalve
  - New pressure relief diaphragm valve series 475
  - Brass couplings and adapters
- Valves in the assembly: 8630011H (n. 2÷4) + 8630001H + 8630020 + 475514 (40 bar) / 475512 (20 bar) + 34520030 (in units with filter)

- Electroválvula con retornos calibrados para distribución constante
  - Electroválvula de regulación proporcional
  - Electroválvula de descarga
  - Nueva válvula de máxima presión de diafragma serie 475
  - Bridas de latón
- Con válvulas: 8630011H (n. 2÷4) + 8630001H + 8630020 + 475514 (40 bar) / 475512 (20 bar) + 34520030 (para grupos con filtro)

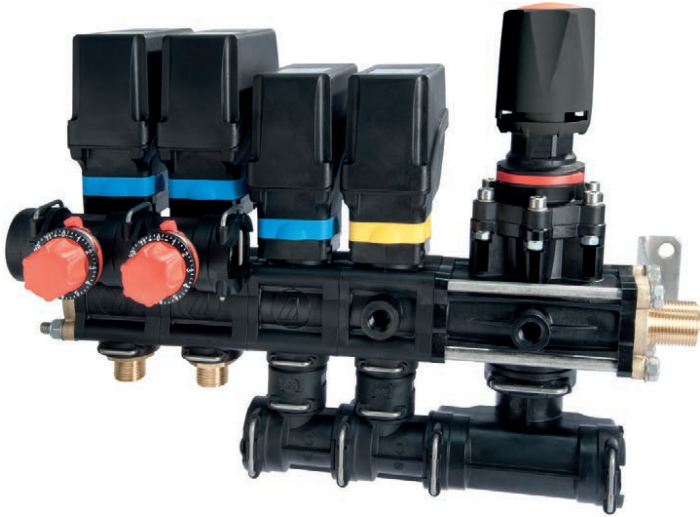

Con filtro With filter Con filtro	Senza filtro Without filter Sin filtro	Vie Ways Vias	bar		PSI		lt/1' / US GPM	
			20	40	290	580	120	32
<b>863 525 2EAH</b>	<b>863 525 2E0H</b>	2	20	40	290	580	120	32
<b>863 525 4EAH</b>	<b>863 525 4E0H</b>							
<b>863 545 2EAH</b>	<b>863 545 2E0H</b>	4	20	40	290	580	120	32
<b>863 545 4EAH</b>	<b>863 545 4E0H</b>							



**T4**  
fork  
coupling

Accessori di completamento nel capitolo:  
Accessories available in chapter:  
Accesorios de terminación en el capítulo:

**FITTINGS**

Cavi e spine DIN a 3 fili  
3-wires DIN cables and plugs  
Cables y tomas DIN a 3 hilos

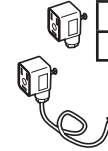

COD. / CODE / CÓD.  
**ECS0033**

COD. / CODE / CÓD.  
**8650900.140** (1.3 m)

### Gruppo di comando da atomizzatori per BRAVO 180S e 300S

Composto dalle valvole: 8630020S + 8630011H (n. 2÷4) + 475514 (40 bar) / 475512 (20 bar) + 4621AA30000 (Orion2) + 34520030 (per gruppi con filtro)

### Control unit for BRAVO 180S and 300S for orchard sprayers

Valves in the assembly: 8630020S + 8630011H (n. 2÷4) + 475514 (40 bar) / 475512 (20 bar) + 4621AA30000 (Orion2) + 34520030 (in units with filter)

### Grupos de mando para BRAVO 180S y 300S para atomizadores

Con válvulas: 8630020S + 8630011H (n. 2÷4) + 475514 (40 bar) / 475512 (20 bar) + 4621AA30000 (Orion2) + 34520030 (para grupos con filtro)

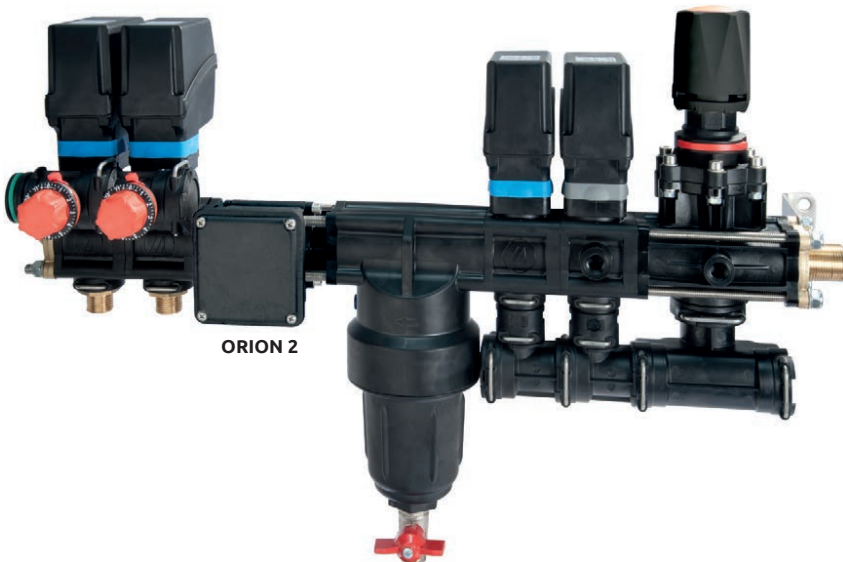

ORION 2



**T4**  
fork  
coupling

Accessori di completamento nel capitolo:  
Accessories available in chapter:  
Accesorios de terminación en el capítulo:

**FITTINGS**

Cavi e spine DIN a 3 fili  
3-wires DIN cables and plugs  
Cables y tomas DIN a 3 hilos

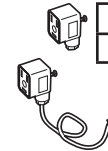

COD. / CODE / CÓD.  
**ECS0033**

COD. / CODE / CÓD.  
**8650900.140** (1.3 m)

Designed for use with BRAVO and DELTA computers



BRAVO 180S / 300S		Vie Ways Vias	bar		PSI		lt/1' / US GPM		Flussometro Flowmeter Caudalímetro
Con filtro With filter Con filtro	Senza filtro Without filter Sin filtro		20	40	290	580	150	40	
<b>863 525 2PACH</b>	<b>863 525 2P0CH</b>	2	20	40	290	580	150	40	<b>ORION2</b>
<b>863 525 4PACH</b>	<b>863 525 4P0CH</b>								
---	<b>863 545 2P0CH</b>	4	20	40	290	580	150	40	
---	<b>863 545 4P0CH</b>								

# GRUPPI DI COMANDO A SOLENOIDE PER ATOMIZZATORI CONTROL UNITS WITH SOLENOID VALVES FOR ORCHARD SPRAYERS GRUPOS DE MANDO CON VÁLVULAS DE SOLENOIDE PARA ATOMIZADORES

481

I nuovi gruppi di comando con valvole a solenoide sono stati studiati per il collegamento ai sistemi elettrici e computerizzati per atomizzatore e trattamento filari dove siano di fondamentale importanza l'apertura e chiusura immediata delle valvole. Estremamente compatti e disponibili in svariate configurazioni, costruiti con materiali ad alta resistenza, possono essere composti da 2, 4 o 6 valvole di sezione.

- Ingombro ridotto.
- Particolari realizzati in Nylon® rinforzato fibra di vetro, ottone e acciaio Inox. Tenute in TEFLON®.
- Elettrovalvole a solenoide 12 Vdc normalmente chiuse.
- Flangia di ingresso in ottone con attacco 3/4" filettato maschio.
- Raccordi di uscita in ottone con attacco a forchetta 1/2" filettato maschio compatibile con tutti i raccordi per valvole serie 863.
- Filtro autopulente integrato.
- Valvola di massima pressione integrata.
- Attacco per manometro filettato G 1/4" integrato.
- Disponibile con valvola di scarico elettrica.

The new control units with solenoid valves are designed to be connected with computerized electrical systems for spraying and row spraying systems requiring immediate valve opening and closing.

Extremely compact and available in several different configurations, high-strength construction, can include 2, 4 or 6 section valves.

- Very compact.
- Parts in fibreglass reinforced Nylon, brass and stainless steel. TEFLON® seals.
- Normally closed 12 Vdc solenoid valves.
- Brass inlet flange with 3/4" threaded male connection.
- Brass outlet connectors with 1/2" threaded male fork connection compatible with all connections of valves series 863.
- Incorporated self-cleaning filter.
- Incorporated maximum pressure valve.
- Incorporated G 1/4" threaded pressure gauge connection.
- Available with electric by-pass valve.

Los nuevos grupos de mando con válvulas de solenoide han sido estudiados para la conexión a los sistemas eléctricos y computerizados para atomizador y tratamiento de hileras donde es de fundamental importancia la apertura y cierre inmediato de las válvulas.

Extremadamente compactos y disponibles en varias configuraciones, construidos con materiales de alta resistencia, pueden estar compuestos por 2, 4 o 6 válvulas de sección.

- Dimensiones reducidas
- Componentes realizados en Nylon reforzado con fibra de vidrio, latón y acero Inox. Estanqueidades de Teflón®.
- Electroválvulas de solenoide 12 Vdc normalmente cerradas
- Brida de ingreso de latón con acople 3/4" rosca macho.
- Acoples de salida en latón con acople de horquilla 1/2" rosca macho compatible con todos los acoples para válvulas serie 863.
- Filtro autolimpiante integrado.
- Válvula de máxima presión integrada.
- Toma para manómetro roscada G 1/4" integrada.
- Disponible con válvula de descarga eléctrica.

Blocco valvola generale, valvola proporzionale, valvola di massima pressione e filtro inglobati in un solo corpo.

Main valve block; proportional valve, max. pressure valve and filter built into a single body.

Bloque válvula general, válvula proporcional, válvula de máxima presión y filtro en un solo cuerpo.

Filtro frontale con sistema di pulizia automatica.

Front self-cleaning filter.

Filtro delantero con sistema de limpieza automática.

Particolari interni realizzati con materiali anticorrosione e antiusura.

Internal parts made from corrosion and wear resistant materials.

Componentes internos realizados con materiales anticorrosión y antidesgaste.

Attacco manometro 1/4" integrato nel corpo. (manometro da acquistare separatamente)

1/4 threaded pressure gauge connection incorporated in module body. (pressure gauge must be ordered separately)

Toma manómetro 1/4" integrada en el cuerpo. (el manómetro se debe pedir por separado)

Raccordo di ingresso G 3/4 M in ottone, con attacco a forchetta.

G 3/4 M brass inlet connector with fork coupling.

Acople de entrada G 3/4 M en latón, con toma de horquilla.

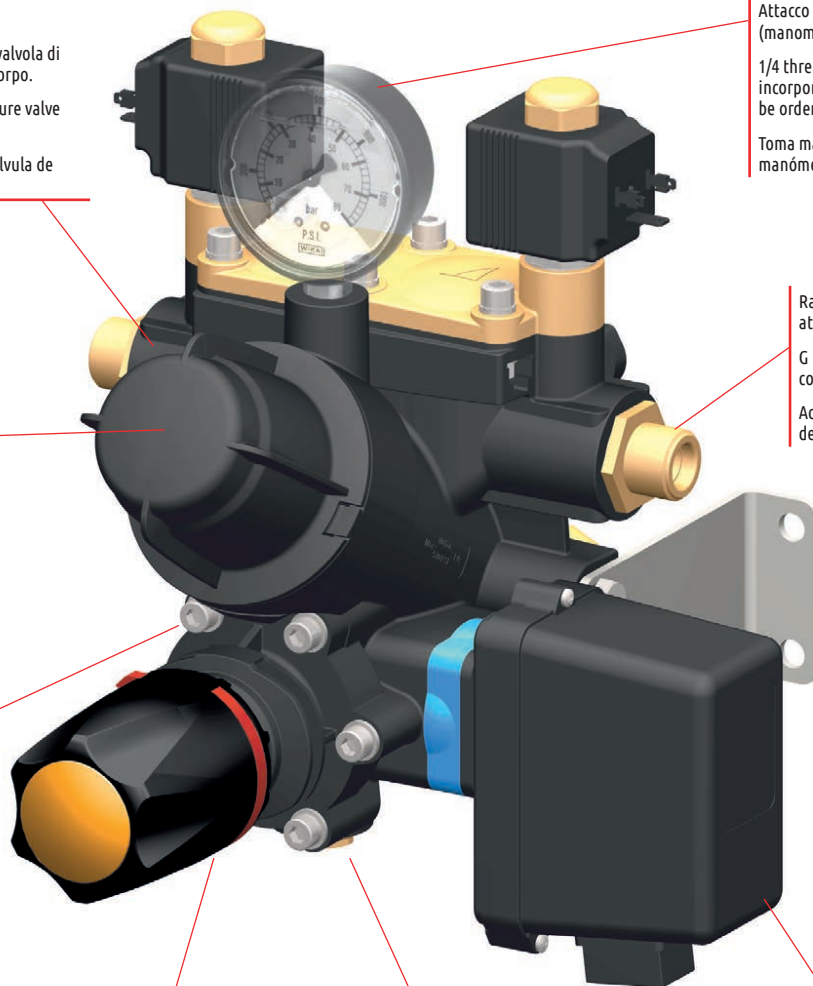

Valvola di massima pressione ad alta portata con gruppo membrana di elevata sensibilità.

High flow rate max. pressure valve with highly sensitive membrane unit.

Válvula de máxima presión de alto caudal con grupo membrana de elevada sensibilidad.

Attacco supplementare con filetto G 1/2 F per spurgo o ausiliari non filtrati.

Additional G 1/2 F connector for non-filtered drainage or auxiliary devices.

Toma suplementaria con rosca G 1/2 H para purga o auxiliares no filtrados.

Versione con valvola di messa in scarico.

Version with by-pass valve.

Versión con válvula de puesta en descarga.

Valvola di regolazione manuale serie 475, filtro 50 mesh, 2, 4 o 6 sezioni.

Manual control valve series 475, 50 filter mesh, 2, 4 or 6 sections.

Válvula de regulación manual serie 475, filtro 50 mesh, 2, 4 o 6 secciones.



COD. CODE CÓD.	Vie Ways Vías	⌚		⚡	⚙️	
		bar	PSI		lt/1'	US GPM
<b>481 814202</b>	2	40	580	2,3 A*	150	40
<b>481 814204</b>	4					
<b>481 814206</b>	6					

\* Assorbimento della singola valvola in apertura  
Single valve absorption during opening stage  
Absorción de una válvula en apertura



Valvola di regolazione manuale serie 475, filtro 50 mesh, valvola di scarico elettrica ON/OFF, 2, 4 o 6 sezioni.

Manual control valve series 475, 50 filter mesh, electric ON/OFF by-pass valve, 2, 4 or 6 sections.

Válvula de regulación manual serie 475, filtro 50 mesh, válvula de descarga eléctrica ON/OFF, 2, 4 o 6 secciones.



COD.  
CODE  
CÓD.  
**4668 5236**

Scatola di comando serie 4668 per gruppo di comando a 2 vie con valvola di scarico serie 863 a pag. B-83.  
Series 4668 control box for 2-way control unit with series 863 drain valve on page B-83.  
Caja de mando serie 4668 para grupo de mando de 2 vías con válvula de descarga serie 863 en pág. B-83.



COD. CODE CÓD.	Vie Ways Vías	⌚		⚡	⚙️	
		bar	PSI		lt/1'	US GPM
<b>481 914202</b>	2	40	580	2,3 A*	150	40
<b>481 914204</b>	4					
<b>481 914206</b>	6					

\* Assorbimento della singola valvola in apertura  
Single valve absorption during opening stage  
Absorción de una válvula en apertura



Scatole di comando serie 4669 per gruppi di comando a 4 e 6 vie con valvola di scarico serie 863 a pag. B-78.  
Series 4669 control box for 4-way and 6-way control units with series 863 drain valve on page B-78.  
Cajas de mando serie 4669 para grupos de mando de 4 y 6 vías con válvula de descarga serie 863 en pág. B-78.

COD. CODE CÓD.	Vie Ways Vías
<b>4669 8461</b>	4
<b>4669 8661</b>	6

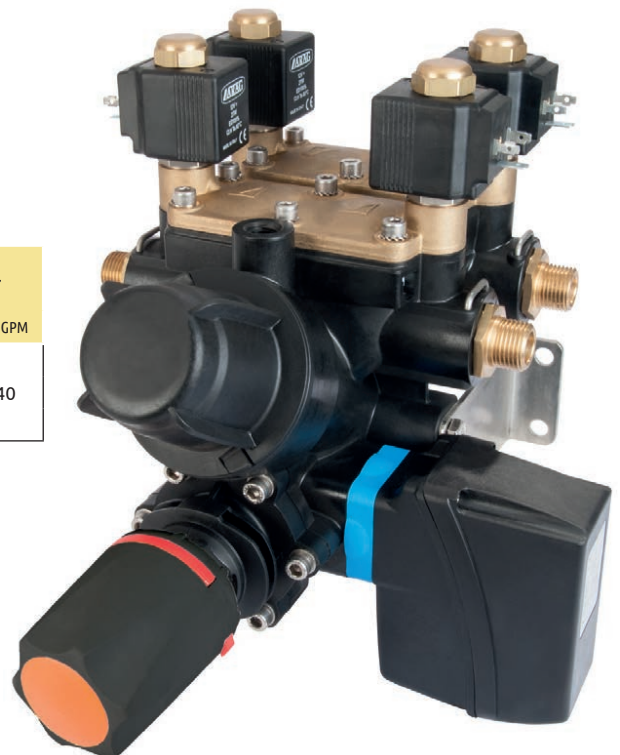

# GRUPPI DI COMANDO A SOLENOIDE PER ATOMIZZATORI CONTROL UNITS WITH SOLENOID VALVES FOR ORCHARD SPRAYERS GRUPOS DE MANDO CON VÁLVULAS DE SOLENOIDE PARA ATOMIZADORES

481

- Elettrovalvole a solenoide 12 Vdc normalmente chiuse.
- Singolo corpo con due valvole a solenoide, modulare.
- Flangia di ingresso in ottone con attacco 3/4" filettato maschio.
- Raccordi di uscita in ottone con attacco a forchetta 1/2" filettato maschio compatibile con tutti i raccordi per valvole serie 863.

- 12 Vdc normally-closed electric solenoid valves.
- Single body with two solenoid valves, modular design.
- Brass inlet flange with male 3/4" connector.
- Brass outlet connectors with male 1/2" threaded fork coupling compatible with all 863 series connectors.

- Electroválvulas de solenoide 12 Vdc normalmente cerradas.
- Cuerpo individual con dos válvulas de solenoide, modular.
- Brida de entrada de latón con toma 3/4" roscada macho.
- Empalmes de salida de latón con toma de horquilla 1/2" roscada macho compatible con todos los acoples para válvulas serie 863.



COD. CODE CÓD.	Vie Ways Vias	bar		PSI	⚡	lt/1'		US GPM	
		40	580			90÷120	24÷32	150	40
481 600002	2								
481 600004	4				2,3 A*				



\* Assorbimento della singola valvola in apertura  
Single valve absorption during opening stage  
Absorción de una válvula en apertura

- Elettrovalvola singola a solenoide 12 Vdc normalmente chiusa.
- Modulare.
- Corpo in ottone con attacchi 1/2" filettati femmina.

- Normally-closed 12 V dc solenoid single electric valve.
- Modular features.
- Brass body with female 1/2" threaded couplings.

- Electroválvula individual de solenoide 12 Vdc normalmente cerrada.
- Modular.
- Cuerpo de latón con empalmes 1/2" roscados hembra.



COD. CODE CÓD.	bar		PSI	⚡	lt/1'		US GPM	
	40	580			90÷120	24÷32		
481 611				2,3 A*				

\* Assorbimento della valvola in apertura  
Valve absorption during opening stage  
Absorción de la válvula en apertura



# 4668 - 4669

SCATOLE DI COMANDO  
CONTROL BOXES  
CAJAS DE MANDO

C113



Le scatole serie **4668** e **4669** per gruppi di comando elettrici sono l'evoluzione delle precedenti serie 4661, 4663 e 4664 e si distinguono per caratteristiche funzionali uniche che le rendono comode ed affidabili. Dotate dei nuovi interruttori heavy duty garantiscono un'eccezionale resistenza all'uso e alle sollecitazioni. Il design modulare e completamente configurabile rende queste scatole di comando comode per essere inserite anche dove c'è poco spazio.

Le scatole di comando serie **4668** e **4669** sono dotate di un pratico fissaggio con innesto a baionetta e sono disponibili nelle versioni per gruppi di comando fino a 7 sezioni, per valvole motorizzate o a solenoide, per gruppi idraulici e per applicazioni speciali.

## CARATTERISTICHE GENERALI

- Modelli per la gestione da 1 a 7 sezioni.
- Possibilità di selezionare il funzionamento M o P.
- Progettate per essere collegate alle nuove valvole di sezione serie 863.
- Nuovi interruttori heavy duty protetti con cappuccio in gomma.
- Tensione di alimentazione 12 Vdc.
- Indicatori LED ad alta luminosità.
- Fusibile generale di protezione autoripristinante.
- Tenuta contro le infiltrazioni d'acqua
- Possibilità di fissare sopra o sul lato sinistro della scatola di comando un manometro esterno o il visualizzatore digitale DIGIBLOCK, con apposito kit con attacco a forchetta.

The **4668** and **4669** series boxes for electric control units are the evolution of the 4661, 4663 and 4664 series and feature unique functional characteristics for the utmost convenience and reliability. Equipped with the new heavy-duty switches, they ensure exceptional durability and stress resistance. Thanks to their modular, fully configurable design, these control boxes fit into limited space applications. The **4668** and **4669** series control boxes feature a practical bayonet coupling and are available for control units with up to 7 sections, for electronic or solenoid valves, hydraulic units and special applications.

## GENERAL FEATURES

- Models capable of handling from 1 to 7 sections.
- Possibility to select M or P operation.
- Designed to be connected to the new section valves, series 863.
- New heavy-duty switches with rubber cover.
- Power supply voltage 12 Vdc.
- High brightness LED indicators.
- Main self-recovering fuse.
- Sealed against water infiltration
- External pressure gauge or digital display "DIGIBLOCK" can be connected either at the left side or on the top of the control box using dedicated fork coupling kit.

Las cajas serie **4668** y **4669** para grupos de mando eléctricos son la evolución de las anteriores series 4661, 4663 y 4664 y se distinguen por las características de funcionamiento únicas que las hacen cómodas y confiables. Dotadas de los nuevos interruptores heavy duty garantizan una excepcional resistencia al uso y a las sollicitaciones. El diseño modular y completamente configurable hace que estas cajas de mando sean cómodas para ser introducidas aún donde hay poco espacio. Las cajas de mando serie **4668** y **4669** están dotadas de una práctica fijación con acople de bayoneta y están disponibles en las versiones para grupos de mando hasta 7 secciones, para válvulas motorizadas o de solenoide, para grupos hidráulicos y para aplicaciones especiales.

## CARACTERÍSTICAS GENERALES

- Modelos para la gestión desde 1 hasta 7 secciones.
- Posibilidad de seleccionar el funcionamiento M o P.
- Proyectadas para ser conectadas a las nuevas válvulas de sección serie 863.
- Nuevos interruptores heavy duty protegidos con capuchón de goma.
- Tensión de alimentación 12 Vdc.
- Indicadores LED de alta luminosidad.
- Fusible general de protección autorregenerable.
- Estanqueidad contra las filtraciones de agua.
- Posibilidad de conectar al lado izquierdo o en la parte arriba de la caja de mando un manómetro medidor de presión o el visualizador digital "DIGIBLOCK", mediante kit específico con empalme de horquilla.



Scatole di comando serie 4669: i cavi di collegamento (alimentazione e valvole) sono solidali in un unico passacavo e basculanti per poter essere posizionati a piacimento con sicurezza.

Control boxes series 4669: connection cables (for power supply and valves) are held together in a single cable holder; swing-style design allows for safe placement in any position.

Cajas de mando serie 4669: los cables de conexión (alimentación y válvulas) son solidarios en un único pasacable y basculantes para poder ser posicionados a gusto con seguridad.

# SCATOLE DI COMANDO PER DISERBO CONTROL BOXES FOR CROP SPRAYING CAJAS DE MANDO PARA PULVERIZACIÓN

# 4669

- Regolazione della pressione.
- Cavo per collegamento sezioni dotato di connettore ad attacco rapido con innesto a slitta.
- Cavo di alimentazione lungh. 2 mt. e cavo sezioni lungh. 50 cm, rotanti e posizionabili a piacere (solo serie 4669).
- Cavi di completamento per collegamento sezioni da 3 a 5 metri, da ordinare separatamente.

- Pressure adjustment.
- Cable for section connections featuring for quick connector with slide lock.
- 2 m power supply cable and 50-cm section cables can be pivoted to any position.
- 3 or 5 m long complement cables for section connections – must be ordered separately.

- Regulación de la presión.
- Cable para conexión secciones con conector de toma rápida con acople de corredera.
- Cable de alimentación long. 2 mt. y cable secciones long. 50 cm, que se pueden rotar y posicionar a gusto.
- Cables para completar la conexión secciones de 3 o 5 metros, se deben ordenar por separado.



COD. CODE CÓD.	Sezioni Sections Vías	Tracciafile Foam marker Marcador de espuma
4669 5333	3	-
4669 5353	3	●
4669 5533	5	-
4669 5553	5	●
4669 5733	7	-



**\*Non compatibili con valvole elettriche di sezione con motoriduttori a 2 fili serie 463-473.  
\*Not compatible with section electric valves with 2-wire gearmotors, series 463-473.  
\*No compatibles con válvulas eléctricas de sección con motorreductores de 2 cables, serie 463-473.**

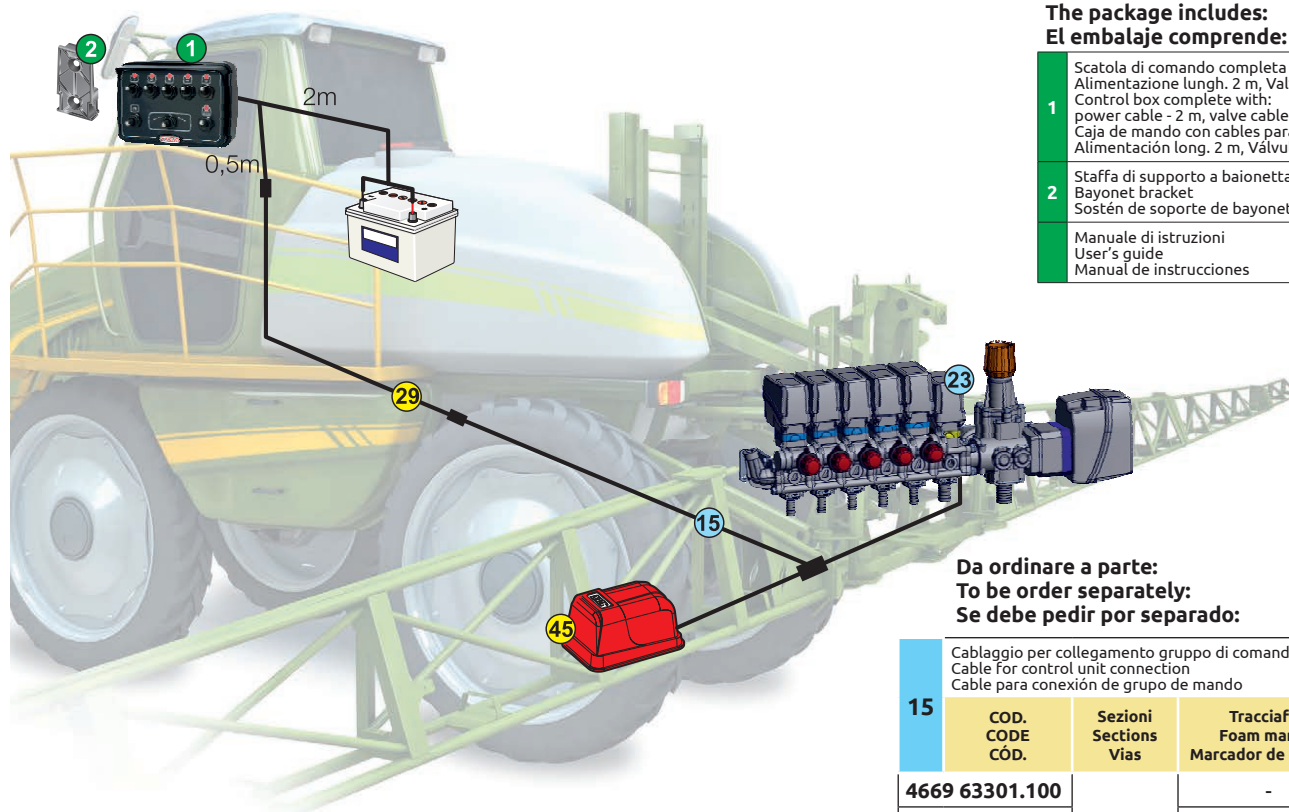

### La confezione comprende:

### The package includes:

### El embalaje comprende:

1	Scatola di comando completa di cavi: Alimentazione lungh. 2 m, Valvole lungh. 0,5 m. Control box complete with: power cable - 2 m, valve cable - 0,5 m Caja de mando con cables para: Alimentación long. 2 m, Válvulas long. 0,5 m
2	Staffa di supporto a baionetta Bayonet bracket Sostén de soporte de bayoneta
	Manuale di istruzioni User's guide Manual de instrucciones

### Da ordinare a parte:

### To be order separately:

### Se debe pedir por separado:

15	COD. CODE CÓD.	Sezioni Sections Vías	Tracciafile Foam marker Marcador de espuma	Lunghezza Length Long.
	4669 63301.100	3	-	3 mt.
	4669 63302.100		-	5 mt.
	4669 63501.100		●	3 mt.
	4669 63502.100		●	5 mt.
	4669 65301.100	5	-	3 mt.
	4669 65302.100		-	5 mt.
	4669 65501.100		●	3 mt.
	4669 65502.100		●	5 mt.
	4669 67301.100	7	-	3 mt.
	4669 67302.100		-	5 mt.

### Accessori: Accessories: Accesorios:

	COD. CODE CÓD.
29 Prolunga per valvole lungh. 3 m Valves extension cable - 3 m Prolongación para válvulas long. 3 m	4669 001.090
45 Tracciafile Foam marker Marcador de espuma	520005C 5200052C

### Da ordinare a parte:

### To be order separately:

### Se debe pedir por separado:

23 Gruppo di comando con valvola generale Control unit with main valve Grupo de mando con válvula general
---

Cavi terminali per gruppi di comando con valvola di scarico

Terminal cables for control units with drain valve

Cables terminales para grupos de mando con válvula de descarga

Da ordinare a parte:  
To be order separately:  
Se debe pedir por separado:

15	Cablaggio per collegamento gruppo di comando Cable for control unit connection Cable para conexión de grupo de mando			
	COD. CODE CÓD.	Sezioni Sections Vías	Tracciafile Foam marker Marcador de espuma	Lunghezza Length Long.
4669 53301.100	3	-	-	3 mt.
4669 53302.100		-	-	5 mt.
4669 53501.100		●	-	3 mt.
4669 53502.100		●	-	5 mt.
4669 55301.100	5	-	-	3 mt.
4669 55302.100		-	-	5 mt.
4669 55501.100		●	-	3 mt.
4669 55502.100		●	-	5 mt.
4669 57301.100	7	-	-	3 mt.
4669 57302.100		-	-	5 mt.

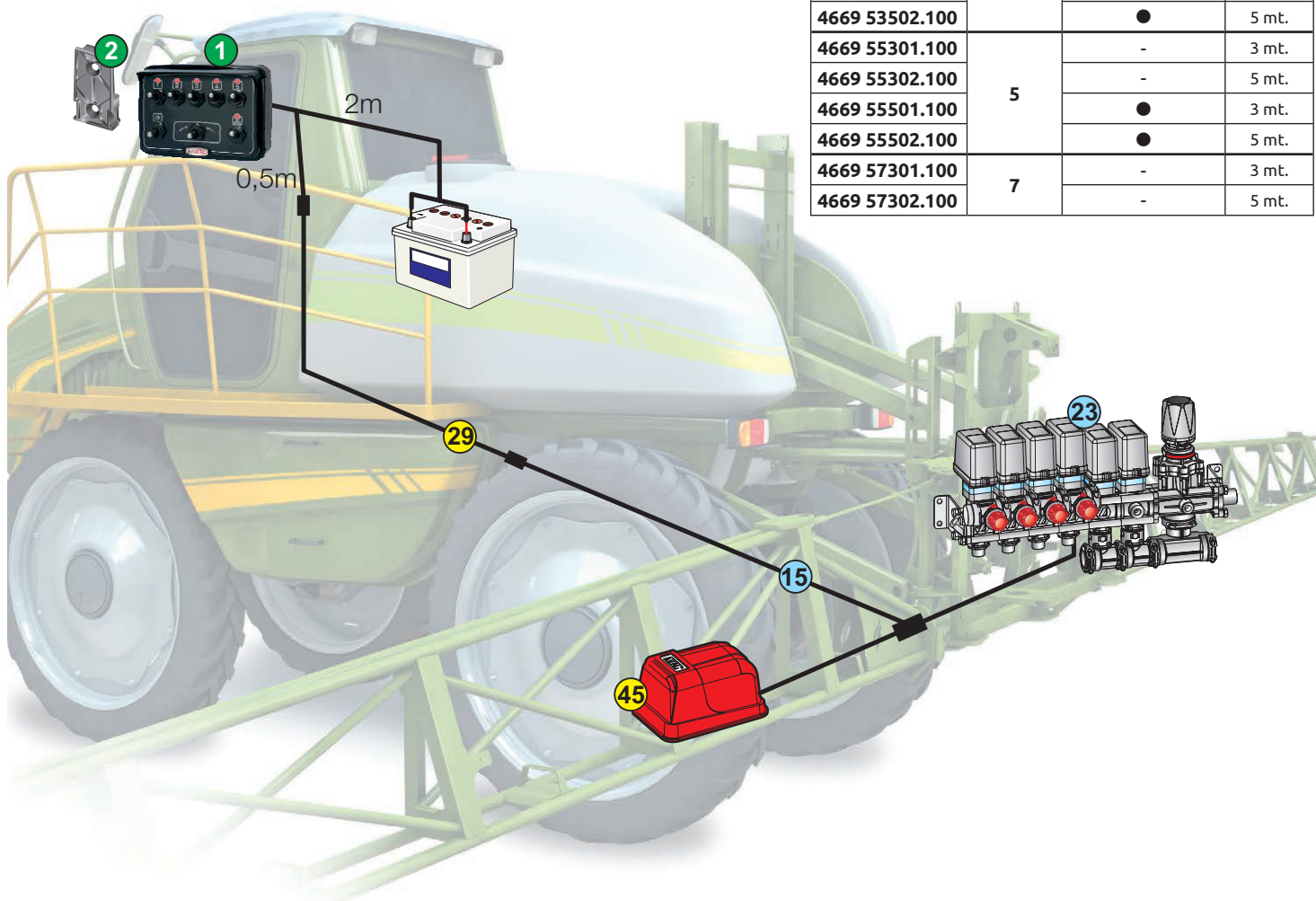

La confezione comprende:  
The package includes:  
El embalaje comprende:

1	Scatola di comando completa di cavi: Alimentazione lungh. 2 m, Valvole lungh. 0,5 m. Control box complete with: power cable - 2 m, valve cable - 0,5 m Caja de mando con cables para: Alimentación long. 2 m, Válvulas long. 0,5 m
2	Staffa di supporto a baionetta Bayonet bracket Sostén de soporte de bayoneta
	Manuale di istruzioni User's guide Manual de instrucciones

Da ordinare a parte:  
To be order separately:  
Se debe pedir por separado:

23	Gruppo di comando con valvola di scarico Control unit with drain valve Grupo de mando con válvula de descarga
----	---

Accessori:  
Accessories:  
Accesorios:

	COD. CODE CÓD.	
29	Prolunga per valvole lungh. 3 m Valves extension cable - 3 m Prolongación para válvulas long. 3 m	4669 001.090
45	Tracciafile Foam marker Marcador de espuma	520005C 5200052C

# SCATOLE DI COMANDO IDRAULICHE HYDRAULIC CONTROL BOXES CAJAS DE MANDO IDRAULICAS

# 4669

## SCATOLA DI COMANDO IDRAULICA SERIE 4669

- Scatola per il comando del movimento di barre idrauliche tramite valvole oleodinamiche a doppia azione
- Comandi per livellamento, altezza, bloccaggio e 2, 4 o 6 movimenti della barra
- Alimentazione 12 Vdc

## HYDRAULIC CONTROL BOX SERIES 4669

- Control box for operating hydraulic booms thanks to double action hydraulic valves
- Levelling, height, locking and 2, 4 or 6 booms motion drives
- Power supply 12 Vdc

## CAJA DE MANDO IDRAULICA SERIE 4669

- Caja de mando del movimiento de las barras hidráulicas por medio de válvulas oleodinámicas de doble acción
- Mandos para nivelamiento, altura, bloqueo y 2, 4 o 6 movimientos de la barra
- Alimentación 12 Vdc



COD. CODE CÓD.	Vie Ways Vías
4669 7020	2 + 3
4669 7040	4 + 3
4669 7060	6 + 3

### Cavi di completamento per collegamento di gruppi di comando idraulici

### Supplementary cables for connection of hydraulic control units

### Cables de terminación para conexión de grupos de mando hidráulicos

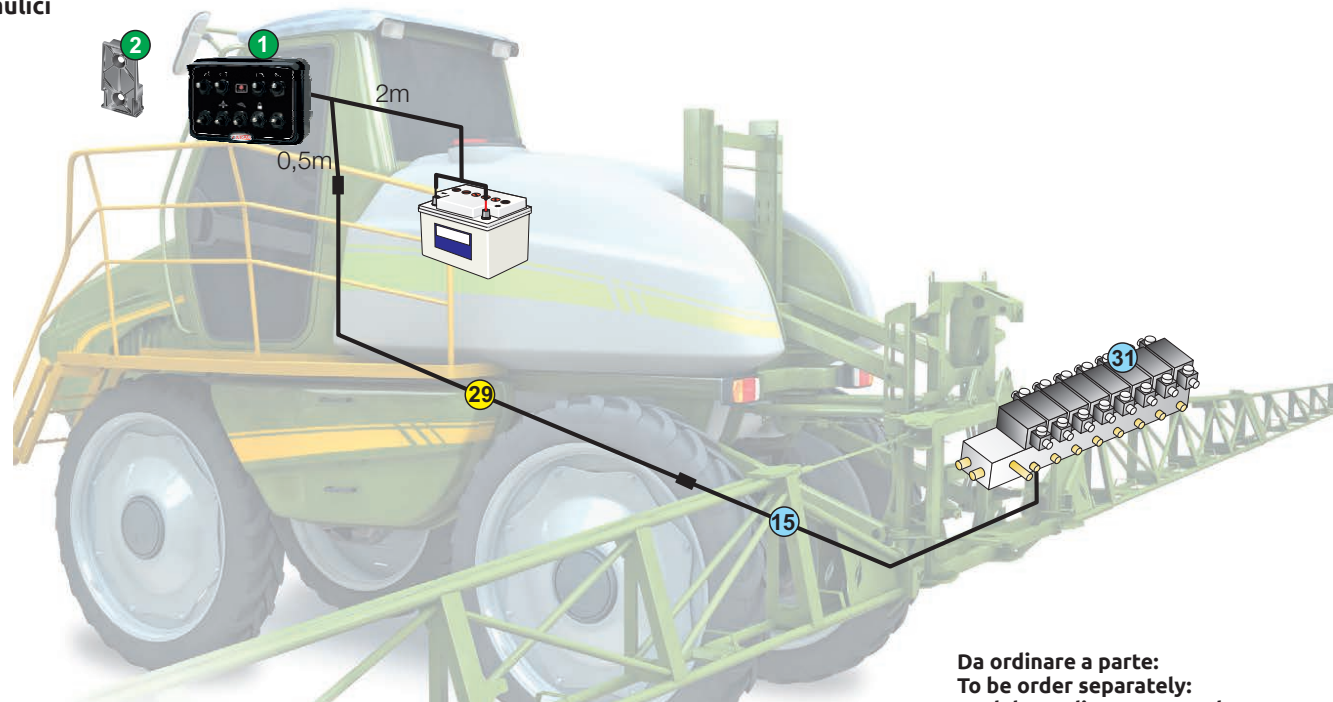

### La confezione comprende: The package includes: El embalaje comprende:

- |   |   |
|---|---|
| 1 | Scatola di comando completa di cavi:<br>Alimentazione lungh. 2 m, Valvole lungh. 0,5 m.<br>Control box complete with:<br>power cable - 2 m, valve cable - 0,5 m<br>Caja de mando con cables para:<br>Alimentación long. 2 m, Válvulas long. 0,5 m |
| 2 | Staffa di supporto a baionetta<br>Bayonet bracket<br>Sostén de soporte de bayoneta  |
|   | Manuale di istruzioni<br>User's guide<br>Manual de instrucciones  |

### Da ordinare a parte: To be order separately: Se debe pedir por separado:

- |    |  |
|----|--|
| 31 | Gruppo di comando idraulico<br>Hydraulic control unit<br>Grupo de mando hidráulico |
|----|--|

### Accessori: Accessories: Accesorios:

- |    |   |               |
|----|---|---------------|
| 29 | Prolunga per valvole lungh. 3 m<br>Valves extension cable - 3 m<br>Prolongación para válvulas long. 3 m | 467 32000.110 |
|----|---|---------------|

### Da ordinare a parte: To be order separately: Se debe pedir por separado:

15	COD. CODE CÓD.	Vie Ways Vías	Lunghezza Length Long.
	4669 70504.100	2 + 3	6 mt.
	4669 70505.100	2 + 3	10 mt.
	4669 70704.100	4 + 3	6 mt.
	4669 70705.100	4 + 3	10 mt.
	4669 70904.100	6 + 3	6 mt.
	4669 70905.100	6 + 3	10 mt.

# GRUPPO VALVOLE IDRAULICHE PER BARRE IRRORATRICI HYDRAULIC VALVES UNIT FOR SPRAYING BOOMS GRUPO VÁLVULAS IDRAULICAS PARA BARRAS PULVERISADORAS

## Gruppo di elettrovalvole modulari per movimenti idraulici barra

- Gruppi da 3 a 9 funzioni
- Valvola pilota per la messa in scarico
- Valvola di massima pressione
- Elettrovalvole a doppio solenoide
- Possibilità di azionamento manuale
- Attacchi filettati uscita valvole, G1/4" maschio
- Attacchi filettati ingresso/uscita gruppo, G 1/2" maschio
- Assorbimento elettrovalvole 27 W
- Tensione di alimentazione 12 Vdc
- Protezione contro agenti corrosivi
- Possibilità di montaggio di valvole di blocco integrate

## Modular electrovalves unit for hydraulic booms

- Units from 3 to 9 functions
- Pilot valve for discharge
- Max. pressure valve
- Double solenoid electrovalves
- Possibility of manual operating
- Threaded valves outlets, G1/4" M
- Threaded inlet and outlet of unit, G1/2" M
- Electrovalve absorption 27W
- Power supply 12 Vdc
- Protection against corrosives
- Possibility of mounting integrated locking valves

## Grupos de electroválvulas modulares para movimientos idraulicos barra

- Grupos desde 3 hasta 9 funciones
- Válvula piloto para la misa en salida
- Válvula de maxima presión
- Electroválvulas de doble solenoide
- Posibilidad de accionamiento manual
- Ataques filetados salida válvulas G 1/4" macho
- Ataques filetados entrada/salida grupo G 1/2"
- Absorción electroválvulas 27 W
- Tension de alimentacion 12 Vdc
- Protección contra agentes corrosivos
- Posibilidad de montaje de válvulas de bloque integradas



COD. CODE CÓD.	Tipo Type Tipo	Pressure		Flow	
		bar	PSI	lt/1'	US GPM
P151 10 764	3 valv. +1 (*)	250	3625	30	8
P151 10 597	4 valv. +1 (*)				
P151 10 696	5 valv. +1 (*)				
P151 10 558	6 valv. +1 (*)				
P151 10 419	7 valv. +1 (*)				
P151 10 765	8 valv. +1 (*)				
P151 10 766	9 valv. +1 (*)				

\*= 1, scarico  
= 1, outlet  
= 1, salida

**Connettori per elettrovalvole idrauliche  
Sockets for hydraulic electrovalves  
Conector para electroválvulas hidráulicas**



COD.  
CODE  
CÓD.  
**ECS0025**

## Kit valvola di ritegno

Valvole di non ritorno per impedire la perdita di pressione nei pistoni idraulici

- Flangiatura per valvole idrauliche Arag
- Facile e rapido montaggio
- Fornito con viti di fissaggio
- Protezione contro agenti corrosivi

## Stop Valve Kit

No return valve to avoid pressure failure inside the hydraulic cylinders

- Flanges for Arag hydraulic valves
- Easy and fast assembly
- Supplied with fixing screws
- Protected against corrosives

## Kit Válvula Obturadora

Válvula di non retroceso para evitar caídas de presión en los cilindros hidráulicos

- Bridas para válvulas hidráulicas Arag
- Montaje fácil y rápido
- Suministrado con tornillos de montaje
- Protección contra los agentes corrosivos

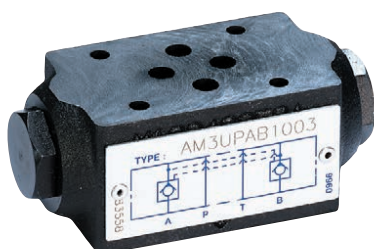

COD. CODE CÓD.	Pressure		Flow	
	bar	PSI	lt/1'	US GPM
PAM 3 UPAB 1	250	3625	30	8



COD. CODE CÓD.	Sezioni Sections Vias	Valvola di scarico By-pass valve Válvula de descarga	Pressione Pressure Presión	Chiusura raggiera Boom closing Cierre barra atomizadora
4669 8461	4	●	●	●
4669 8661	6	●	●	●

Le scatole di comando serie **4669** per atomizzatore sono state progettate per l'abbinamento a gruppi di comando sia con valvole motorizzate serie 863/873 che con valvole a solenoide serie 881 e sono dotate di caratteristiche funzionali uniche che le rendono comode ed affidabili.

Disponibili anche in versioni speciali, per il comando di attuatori e paratie, sono la soluzione ideale nei piccoli atomizzatori.

#### CARATTERISTICHE GENERALI

- Modelli per la gestione di 4 o 6 semiraggiera d'uscita.
- Comando di chiusura di una raggiera completa.
- Comando della valvola di scarico.
- Regolazione della pressione.
- Cavo per collegamento sezioni dotato di connettore ad attacco rapido con innesto a slitta.
- Cavo di alimentazione lungh. 2 mt. e cavo sezioni lungh. 50 cm, rotanti e posizionabili a piacere.
- Cavi di completamento per collegamento sezioni da 3 o 5 metri, da ordinare separatamente.

The orchard sprayer control boxes of the **4669** series have been designed to operate in combination with control units both with electronic valves of the 863/873 series and solenoid valves of the 881 series. They offer unique features for the utmost convenience and reliability.

Also available in special versions for the control of actuators and guards, they represent the ideal solution for small orchard sprayers.

#### GENERAL FEATURES

- Models capable of handling 4 or 6 output half-booms.
- Close control for one complete boom.
- By-pass valve control.
- Pressure adjustment.
- Cable for section connections featuring for quick connector with slide lock.
- 2 m power supply cable and 50-cm section cables can be pivoted to any position.
- 3 or 5 m long complement cables for section connections – must be ordered separately.

Las cajas de mando serie **4669** para atomizador han sido diseñadas para que sean combinadas a grupos de mando con válvulas motorizadas serie 863/873 o válvulas de solenoide serie 881 y están dotadas de características de funcionamiento que las hacen cómodas y confiables.

También disponibles en versiones especiales, para el mando de actuadores y mamparas, son la solución ideal en los pequeños atomizadores.

#### CARACTERÍSTICAS GENERALES

- Modelos para la gestión de 4 o 6 semi barras atomizadoras de salida.
- Mando de cierre de una barra atomizadora completa.
- Mando de la válvula de descarga.
- Regulación de la presión.
- Cable para conexión secciones con conector de toma rápida con acople de corredera.
- Cable de alimentación long. 2 mt. y cable secciones long. 50 cm, que se pueden rotar y posicionar a gusto.
- Cables para completar la conexión secciones de 3 o 5 metros, se deben ordenar por separado.

**La confezione comprende:  
The package includes:  
El embalaje comprende:**

1	Scatola di comando completa di cavi: Alimentazione lungh. 2 m, Valvole lungh. 0,5 m. Control box complete with: power cable - 2 m, valve cable - 0,5 m Caja de mando con cables para: Alimentación long. 2 m, Válvulas long. 0,5 m
2	Staffa di supporto a baionetta Bayonet bracket Sostén de soporte de bayoneta
	Manuale di istruzioni User's guide Manual de instrucciones

**Da ordinare a parte:  
To be order separately:  
Se debe pedir por separado:**

15	Cablaggio per collegamento gruppo di comando Cable for control unit connection Cable para conexión de grupo de mando
23	Gruppo valvole a solenoide Solenoid valve unit Grupo válvulas de solenoide

**Accessori:  
Accessories:  
Accesorios:**

**COD.  
CODE  
CÓD.**

29	Prolunga per valvole lungh. 3 m Valves extension cable - 3 m Prolongación para válvulas long. 3 m	4669 001.090
----	---	--------------

**Cavi di completamento per  
collegamento di gruppi atomizzatori con  
valvole MOTORIZZATE**

**Accessory cables for connecting orchard  
sprayers with MOTORIZED valves**

**Cables para completar las conexiones  
de grupos atomizadores con válvulas  
MOTORIZADAS**

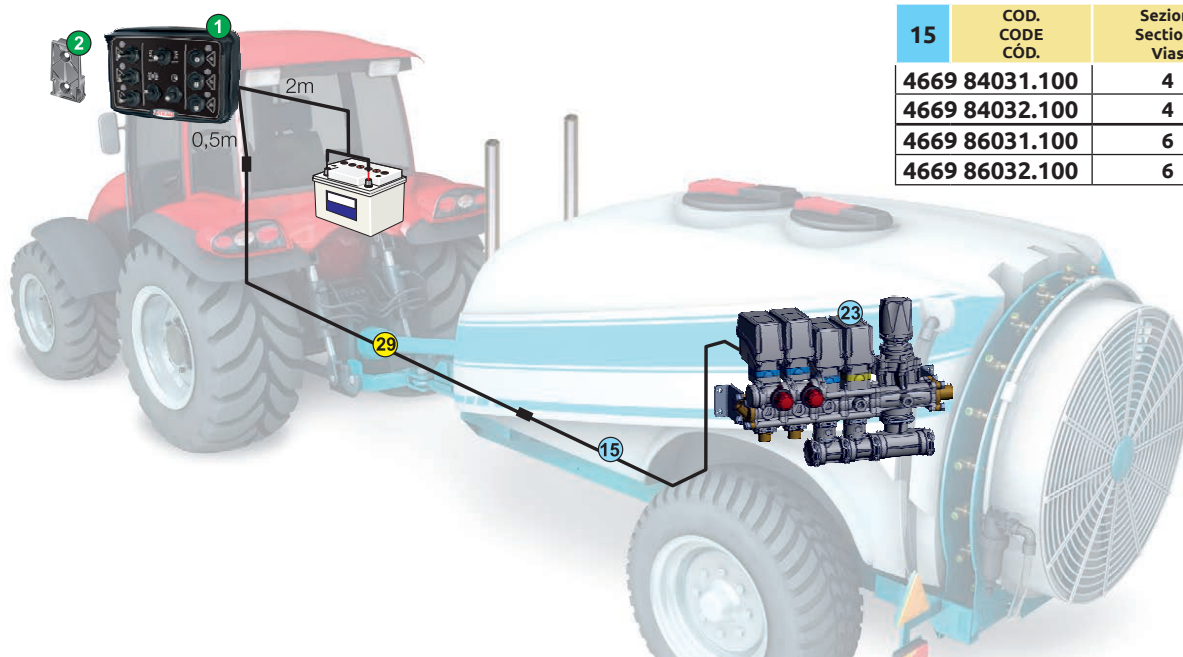

15	COD. CODE CÓD.	Sezioni Sections Vias	Lunghezza Length Long.
	4669 84031.100	4	3 mt.
	4669 84032.100	4	5 mt.
	4669 86031.100	6	3 mt.
	4669 86032.100	6	5 mt.

**Cavi di completamento per  
collegamento di gruppi atomizzatori con  
valvole a SOLENOIDE**

**Accessory cables for connecting  
orchard sprayers with SOLENOID valves**

**Cables para completar las conexiones  
de grupos atomizadores con válvulas de  
SOLENOIDE**



15	COD. CODE CÓD.	Sezioni Sections Vias	Lunghezza Length Long.
	4669 84011.100	4	3 mt.
	4669 84012.100	4	5 mt.
	4669 86011.100	6	3 mt.
	4669 86012.100	6	5 mt.

# SCATOLE DI COMANDO PER ATOMIZZATORE CON ATTUATORI CONTROL BOXES FOR ORCHARD SPRAYER WITH ACTUATORS CAJAS DE MANDO PARA ATOMIZADOR CON ACTUADORES

4669



## Scatole di comando per atomizzatore con comando attuatori e paratie

Versione per il comando di attuatori regolabili **(1)** che permette di indirizzare il flusso d'aria su atomizzatori a basso volume, per una migliore copertura fogliare.

Versione per il comando delle paratie **(2)** che consente di arrestare completamente il flusso d'aria per ridurre l'effetto deriva nelle zone di rispetto (buffer zone).

- Versioni per il collegamento di **2 o 4 valvole MOTORIZZATE a 3 fili serie 863.**
- Comando per generale e pressione.
- Versione con 2 comandi per la regolazione di attuatori regolabili.
- Versione con comandi per paratie (APERTO/CHIUSO/AUTO) con possibilità di gestire manualmente o automaticamente l'apertura e la chiusura delle paratie in base allo stato dell'irrorazione.

## Control boxes for orchard sprayer with actuator and guard control

Version for the control of adjustable actuators **(1)** that makes it possible to direct air flow on low-volume orchard sprayers to ensure a better spraying of the leaf surface.

Version for guard control **(2)** that lets you completely stop the air flow to reduce the drift effect in the buffer zones.

- Versions for the connection of **2 or 4 MOTORIZED 3-wire valves of the 863 series.**
- General or pressure control.
- Version with 2 controls to regulate adjustable actuators.
- Version with guard controls (OPEN/CLOSED/AUTO) with possibility of manually or automatically managing the opening and closing of the guards based on the spraying status.

## Cajas de mando para atomizador con mando actuadores y mamparas

Versión para el mando de actuadores regulables **(1)** que permite regular la dirección del flujo de aire en atomizadores de bajo volumen, para una mejor cobertura de las hojas.

Versión para el mando de las mamparas **(2)** que permite detener completamente el flujo de aire para reducir el efecto deriva en las respectivas zonas (buffer zone).

- Versiones para la conexión de **2 o 4 válvulas MOTORIZADAS de 3 hileras serie 863.**
- Mando para general y presión.
- Versión con 2 mandos para la regulación de actuadores regulables.
- Versión con mandos para mamparas (ABIERTO/CERRADO/AUTO) con posibilidad de gestionar manual o automáticamente la apertura y el cierre de las mamparas según el estado de pulverización.

1



COD. CODE CÓD.	Sezioni Sections Secciones	Generale Main valve General	Pressione Pressure Presión	Comando att. regolabili Adjustable actuator ctrl Mando act. ajustables
4669 8253	2	●	●	2
4669 8423	4	●	●	2



2



COD. CODE CÓD.	Sezioni Sections Secciones	Generale Main valve General	Pressione Pressure Presión	Comando att. paratie Guards actuator control Mando act. alas
4669 8213A	2	●	●	2
4669 8413A	4	●	●	2





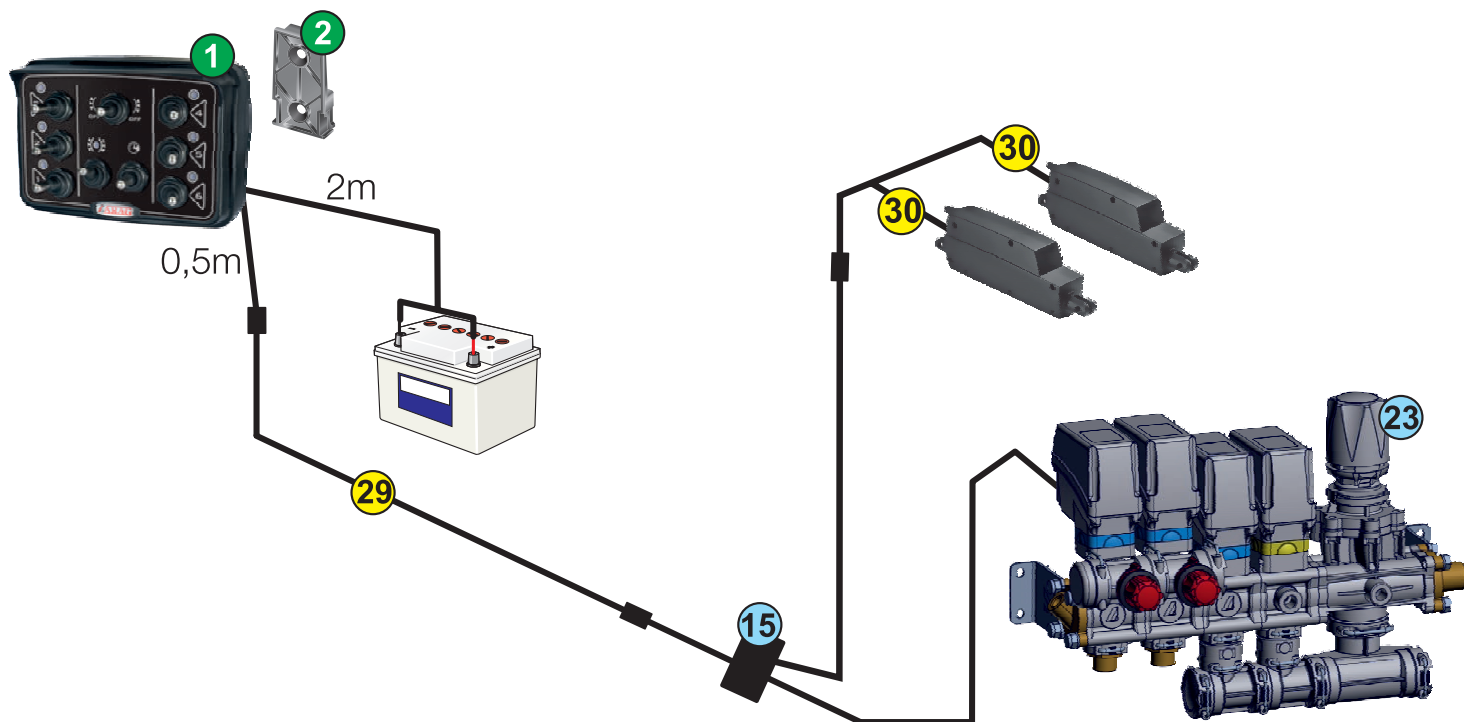

**La confezione comprende:**

**The package includes:**

**El embalaje comprende:**

1	Scatola di comando completa di cavi: Alimentazione lungh. 2 m, Valvole lungh. 0,5 m. Control box complete with: power cable - 2 m, valve cable - 0,5 m Caja de mando con cables para: Alimentación long. 2 m, Válvulas long. 0,5 m
2	Staffa di supporto a baionetta Bayonet bracket Sostén de soporte de bayoneta
	Manuale di istruzioni User's guide Manual de instrucciones

**SOLO per valvole MOTORIZZATE serie 863**  
**ONLY for MOTORIZED valves series 863**  
**SOLO para válvulas MOTORIZADAS serie 863**

**Da ordinare a parte:**

**To be order separately:**

**Se debe pedir por separado:**

	Vie Ways Vias	COD. CODE CÓD.
15	2	4669 82431.100
	2	4669 82432.100
	4	4669 84431.100
	4	4669 84432.100
23		Pag. B-71

**Accessori:**

**Accessories:**

**Accesorios:**

**COD.**

**CODE**

**CÓD.**

29	Prolunga per valvole lungh. 3 m Valves extension cable - 3 m Prolongación para válvulas long. 3 m	467 32000.120
	Prolunga per attuatori lungh. 3 m Extension for actuators with length of 3 m Prolongación para actuadores long. 3 m	4668 002.090
30	Prolunga per attuatori lungh. 5 m Extension for actuators with length of 5 m Prolongación para actuadores long. 5 m	4668 002.091
	Prolunga per attuatori lungh. 7 m Extension for actuators with length of 7 m Prolongación para actuadores long. 7 m	4668 002.092



*Cavo di collegamento sezionabile  
Sectioned connection cable  
Cable de conexión con corte*

# SCATOLE DI COMANDO COMPATTE COMPACT CONTROL BOXES CAJAS COMPACTAS DE MANDO

# 4668

## CARATTERISTICHE GENERALI

- Modelli a 1, 2 e 4 sezioni d'uscita
- Possibilità di comando della valvola generale e di regolazione della pressione
- Disponibili con funzionamento **M** o **P** (vedi tabella codici)

## GENERAL FEATURES

- Models with 1, 2 and 4 output sections
- Available main valve control and pressure settings adjustment
- Available with **M** or **P** operation mode (see code table)

## CARACTERÍSTICAS GENERALES

- Modelos de 1, 2 y 4 secciones de salida.
- Posibilidad de mando de la válvula general y de regulación de la presión.
- Disponibles con funcionamiento **M** o **P** (ver tabla códigos).

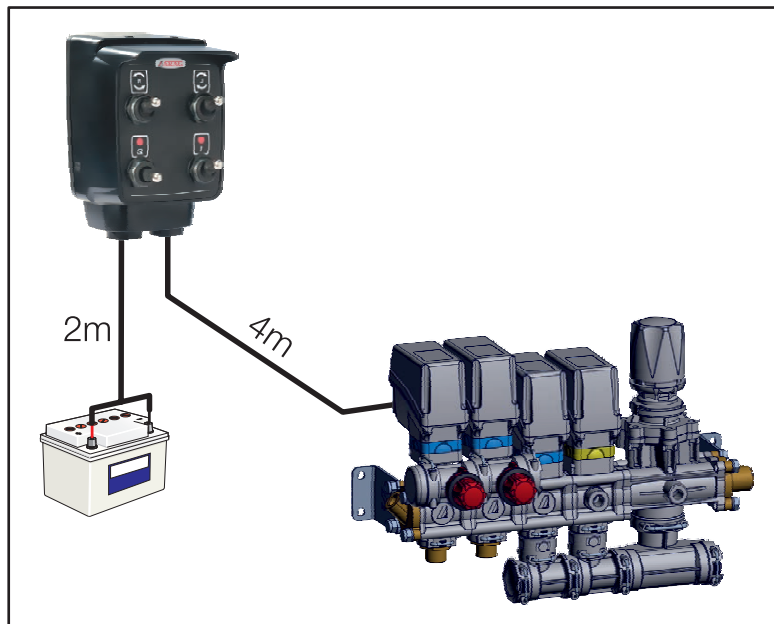

## M / P (Funzionamento - Operation - Funcionamiento)

### M

**Per gruppi con valvole di scarico serie 863/463**  
spostando l'interruttore della valvola generale sulla posizione OFF anche le valvole di sezione vengono automaticamente chiuse

**For control units with discharge valves series 863/463**  
turning OFF the main switch even the section valves are closed automatically.

**Para grupos de mando con válvula de descarga serie 863/463**  
traslando el interruptor de la válvula general en la posición OFF también las válvulas de sección se cierran automáticamente.

### P

**Per gruppi con valvole generali serie 864 e 871**  
le singole sezioni sono indipendenti dalla posizione dell'interruttore generale.

**For control units with main control valves series 864 and 871**  
the single sections are independent from the main switch position.

**Para grupos con válvulas de mando general serie 864 y 871**  
las singulas secciones son endependientes de las posiciones del interruptor general.

**Per valvole con motoriduttore**  
**For motorized valves**  
**Para válvulas con motoreductor**

**Per valvole a solenoide**  
**For solenoid valves**  
**Para válvulas con solenoide**



**SOLO PER GRUPPI DI COMANDO A SOLENOIDE CON VALVOLA DI SCARICO A SOLENOIDE.**

**FOR SOLENOID CONTROL UNITS WITH SOLENOID DRAIN VALVE ONLY.**

**SOLO PARA GRUPOS DE MANDO DE SOLENOIDE CON VÁLVULA DE DESCARGA DE SOLENOIDE.**

COD. CODE CÓD.	Sezioni Sections Vías	Generale Main valve General	Pressione Pressure Presión	Funz. M Funct. M Func. M	Funz. P Funct. P Func. P
4668 5030	-	●	●	-	-
4668 5100	1	-	-	-	-
4668 5101	1	-	-	-	-
4668 5200	2	-	-	-	-
4668 5201	2	-	-	-	-
4668 5210	2	●	-	●	-
4668 5211	2	●	-	●	-
4668 5220	2	-	●	-	-
4668 5230	2	●	●	●	-
4668 5231	2	●	●	●	-
4668 5400	4	-	-	-	-
4668 6210	2	●	-	-	●
4668 6230	2	●	●	-	●

Scatole di comando con cavo sezionabile

Control boxes with sectionable cable

Caja de mando con cable con corte



**Versione per valvole MOTORIZZATE**  
Version for **MOTORIZED** valves  
Version para válvulas **MOTORIZADAS**



COD. CODE CÓD.	Sezioni Sections Vías	Generale Main valve General	Pressione Pressure Presión
<b>4668 5235</b>	2	●	●

**Versione per valvole DI SEZIONE A SOLENOIDE e valvola di scarico MOTORIZZATA SERIE 863**  
Version for **SOLENOID** section valves and **MOTORIZED DRAIN VALVE** SERIES 863

**Versión para válvulas DE SECCIÓN DE SOLENOIDE y válvula de descarga MOTORIZADA SERIE 863**



COD. CODE CÓD.	Sezioni Sections Vías	Generale Main valve General	Pressione Pressure Presión
<b>4668 5236</b>	2	●	●

**La confezione comprende:**

**The package includes:**

**El embalaje comprende:**

<b>1</b>	Scatola di comando completa di cavi: Alimentazione lungh. 2 m, Valvole lungh. 0,5 m. Control box complete with: power cable - 2 m, valve cable - 0,5 m
<b>2</b>	Staffa di supporto a baionetta Bayonet bracket Sostén de soporte de bayoneta
	Manuale di istruzioni User's guide Manual de instrucciones

**Da ordinare a parte:**

**To be order separately:**

**Se debe pedir por separado:**

COD.  
CODE  
CÓD.

<b>15</b>	Cablaggio per collegamento gruppo di comando motorizzato lungh. 3 m Cable for motorized control unit connection length 3 m Cable para conexión de grupo de mando motorizado long. 3 m	<b>4668 02351.100</b>
<b>15</b>	Cablaggio per collegamento gruppo di comando motorizzato lungh. 5 m Cable for motorized control unit connection length 5 m Cable para conexión de grupo de mando motorizado long. 5 m	<b>4668 02352.100</b>
<b>16</b>	Cablaggio per collegamento gruppo di comando a solenoide lungh. 3 m Cable for solenoid control unit connection length 3 m Cable para conexión de grupo de mando de solenoide long. 3 m	<b>4668 02361.101</b>
<b>16</b>	Cablaggio per collegamento gruppo di comando a solenoide lungh. 5 m Cable for solenoid control unit connection length 5 m Cable para conexión de grupo de mando de solenoide long. 5 m	<b>4668 02362.101</b>
<b>23</b>	Gruppo di comando Control unit with Grupo de mando	

**Accessori:**

**Accessories:**

**Accesorios:**

COD.  
CODE  
CÓD.

<b>29</b>	Prolunga per valvole lungh. 3 m Valves extension cable - 3 m Prolongación para válvulas long. 3 m	<b>467 32000.120</b>
-----------	---	----------------------

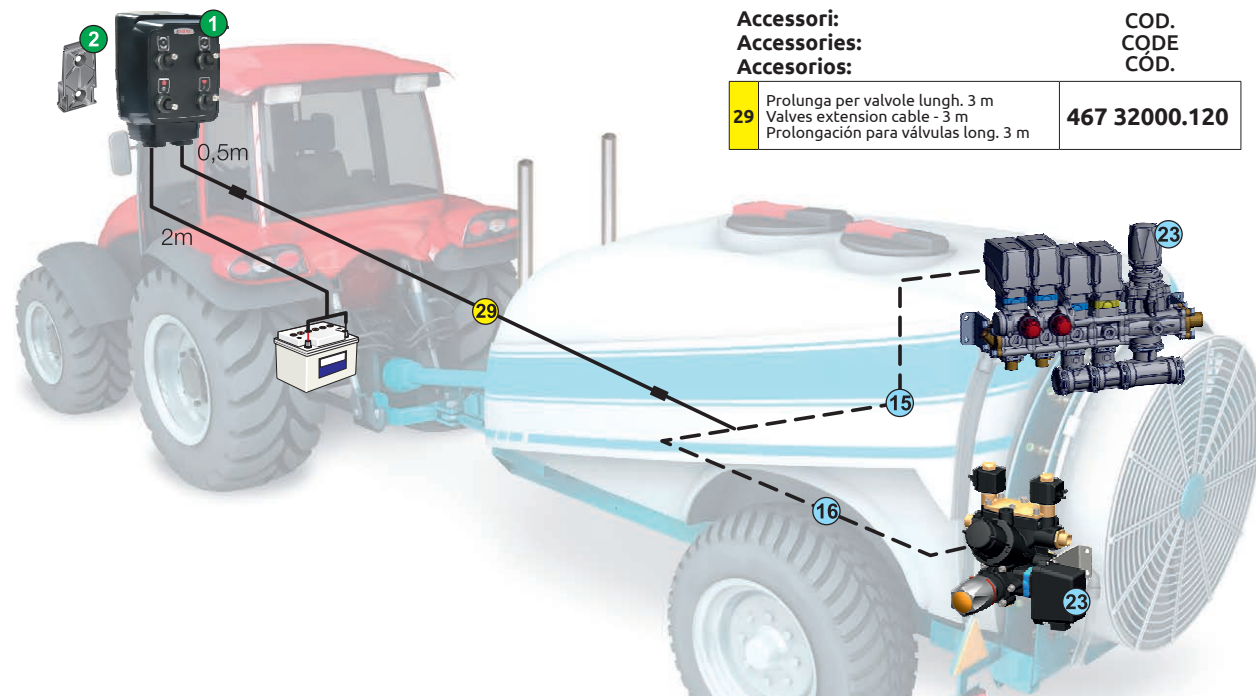

# SCATOLE DI COMANDO PER ATOMIZZATORE CON ATTUATORI CONTROL BOXES FOR ORCHARD SPRAYER WITH ACTUATORS CAJAS DE MANDO PARA ATOMIZADOR CON ACTUADORES

4668

## Scatola di comando per atomizzatore con comando attuatori

La versione per il comando di attuatori regolabili permette di indirizzare il flusso d'aria su atomizzatori a basso volume, per una migliore copertura fogliare.

La versione per il comando delle paratie consente di arrestare completamente il flusso d'aria per ridurre l'effetto deriva nelle zone di rispetto (buffer zone).

- Versione per collegamento a 2 valvole A SOLENOIDE o MOTORIZZATE a 3 fili serie 863.
- Versione con 2 comandi per la regolazione di attuatori regolabili.
- Versione con 2 comandi (ON/ON) per paratie.



## Control box for orchard sprayer with actuators controls

The version for adjustable actuators control regulates air flow direction on low volume orchard sprayers to ensure a better coverage of the leaf surface.

The version for guards control lets you close the air flow completely to reduce the drift effect in the buffer zones.

- Version for the connection of 2 SOLENOID or MOTORIZED 3-wire valves of the 863 series.
- Version with 2 controls to regulate adjustable actuators.
- Version with 2 controls (ON/ON) for guards.



## Caja de mando para atomizador con mando actuadores

La versión para el mando de actuadores ajustables permite regular la dirección del flujo de aire en atomizadores de bajo volumen, para una mejor cobertura de las hojas.

La versión para el mando de las alas permite cerrar completamente el flujo de aire para reducir el efecto deriva en las respectivas zonas (buffer zone).

- Versión para conexión de 2 válvulas DE SOLENOIDE o MOTORIZADAS de 3 hilas serie 863.
- Versión con 2 mandos para la regulación de actuadores ajustables.
- Versión con 2 mandos (ON/ON) para mamparas.



Versione per valvole: Version for valves: Version para válvulas:	COD. CODE CÓD.	Nr. sezioni Sections Num. secciones	Comando att. regol. Adjust. actuator ctrl Mando act. ajust.	Comando att. paratie Guards actuator ctrl Mando act. alas
 MOTORIZZATE MOTORIZED MOTORIZADAS	4668 5253	2	---	2
	4668 5263	2	2	---
Versione per valvole: Version for valves: Version para válvulas:	COD. CODE CÓD.	Nr. sezioni Sections Num. secciones	Comando att. regol. Adjust. actuator ctrl Mando act. ajust.	Comando att. paratie Guards actuator ctrl Mando act. alas
 A SOLENOIDE SOLENOID DE SOLENOIDE	4668 5251	2	---	2
	4668 5261	2	2	---

### La confezione comprende:

### The package includes:

### El embalaje comprende:

1	Scatola di comando completa di cavi: Alimentazione lungh. 2 m, Valvole lungh. 3,5 m. Control box complete with: power cable - 2 m, valve cable - 3,5 m Caja de mando con cables para: Alimentación long. 2 m, Válvulas long. 3,5 m
2	Staffa di supporto a baionetta Bayonet bracket Sostén de soporte de bayoneta
	Manuale di istruzioni / User's guide / Manual de instrucciones

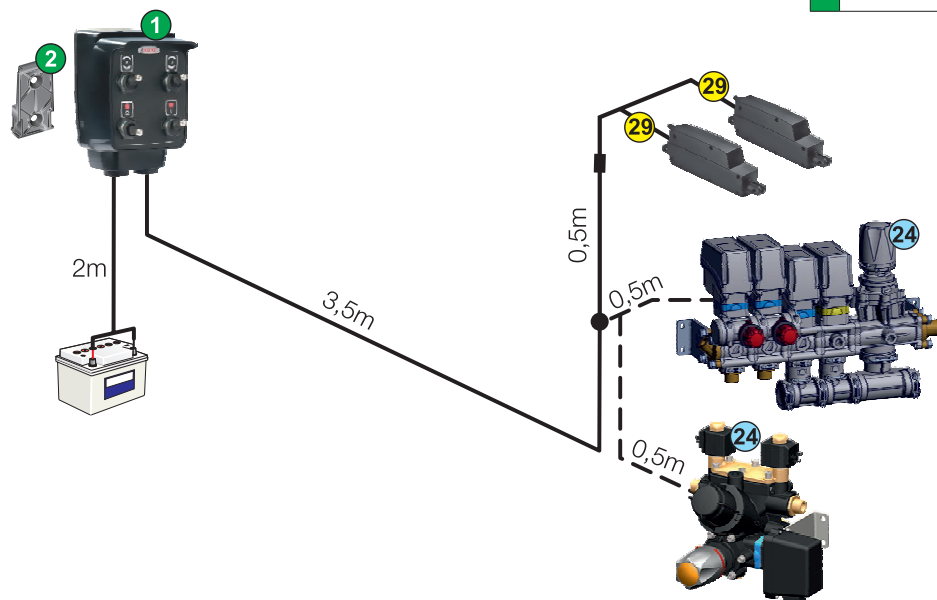

### Accessori: Accessories: Accesorios:

	COD. CODE CÓD.
Prolunga per attuatori lungh. 3 m Actuators extension cable - 3 m Actuadores para válvulas long. 3 m	4668002.090
29 Prolunga per attuatori lungh. 5 m Actuators extension cable - 5 m Actuadores para válvulas long. 5 m	4668002.091
Prolunga per attuatori lungh. 7 m Actuators extension cable - 7 m Actuadores para válvulas long. 7 m	4668002.092

### Da ordinare a parte: To be order separately: Se debe pedir por separado:

24 Gruppo di comando Control unit Grupo de mando
--

designed for **seleTRON**

### Scatola comando per azionamento portagetti fine barra Seletron

- Azionamento degli ugelli di fine barra direttamente dalla cabina.
- Adatta ad ogni tipologia di macchina per irrorazione: montate, trainate, semoventi, ATV.
- Cavo di connessione lungo 7 metri, alimentazione 2 metri.

### Control box for Seletron boom end nozzle holder activation

- Boom end nozzles activated directly from the cabin.
- Suitable to any type of spraying machine: integrated, trailed, self-propelled, ATV.
- 7 m connection cable with 2 m supply

### Caja de mando para accionamiento porta boquillas fin de barra Seletron

- Accionamiento de las boquillas de fin de barra directamente desde la cabina.
- Adecuado para todo tipo de máquina para pulverización: montadas, remolcadas, autopropulsadas, ATV.
- Cable de conexión de 7 metros, alimentación 2 metros.



COD.  
CODE  
CÓD.  
**4668 52043**

#### La confezione comprende: The package includes: El embalaje comprende:

1	Scatola di comando completa di cavi: Alimentazione lungh. 2 m, Seletron lungh. 7 m. Control box complete with: power cable - 2 m, Seletron cable - 7 m Caja de mando con cables para: Alimentación long. 2 m, Seletron long. 7 m
2	Staffa di supporto a baionetta Bayonet bracket Sostén de soporte de bayoneta
	Manuale di istruzioni User's guide Manual de instrucciones

#### Da ordinare a parte: To be order separately: Se debe pedir por separado:

		COD. CODE CÓD.
20	Portagetti Seletron con attacco filettato 1/2" Seletron nozzle holder with 1/2" threaded coupling Porta boquillas Seletron con toma roscada 1/2"	* 4065 T440
	Portagetti Seletron con attacco rapido EASYFIT Seletron nozzle holder with EASYFIT quick fitting Porta boquilla Seletron con acople rápido EASYFIT	* 4065 T840
29	Cavo di collegamento per 2 SELETRON fine barra Connecting cable for 2 end boom Seletron Cable de conexión para 2 Seletron fin de barra	4668 5204.110

\* Portagetti SELETRON nella sezione:  
SELETRON nozzle holders in section:  
Porta boquillas SELETRON en la sección:

**NOZZLES & CAPS**

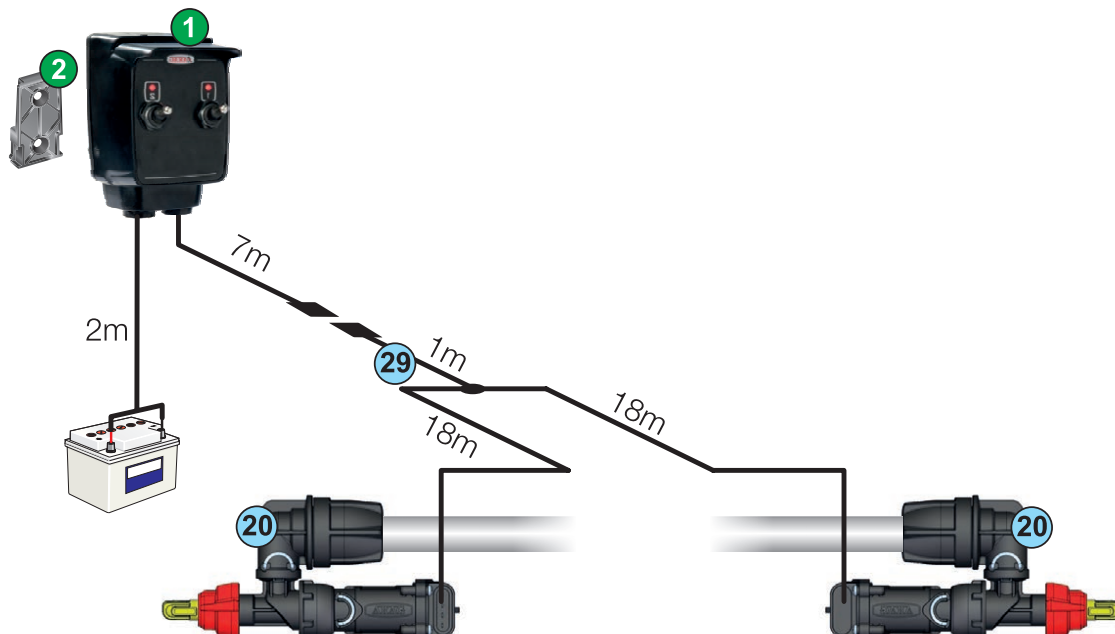

**ACCESSORI PER SCATOLE DI COMANDO**  
**ACCESSORIES FOR CONTROL BOXES**  
**ACCESORIOS PARA CAJAS DE MANDO**

# 4668 - 4669

Kit visualizzatore di pressione digitale DIGIBLOCK per scatole di comando serie **4668** e **4669**, completo di cavi. Grazie agli appositi inserti e all'attacco a forchetta, è possibile posizionare il kit sopra o sul lato sinistro delle scatole della serie 4669 e sopra alle scatole di comando serie 4668.

DIGIBLOCK digital pressure display kit for control boxes series **4668** and **4669**, complete with cables. Suitable inserts and a fork coupling enable this box to be positioned on the top or on the left side of the boxes series 4669 and on top of control boxes series 4668.

Kit visualizador de presión digital DIGIBLOCK con cables para cajas de mando series **4668** y **4669**. Gracias a los específicos insertos y a la toma de horquilla, es posible posicionarla arriba o nel lado izquierdo de las cajas de la serie 4669 y sobre las cajas de mando serie 4668.



COD.  
CODE  
CÓD.  
**4668 3B**

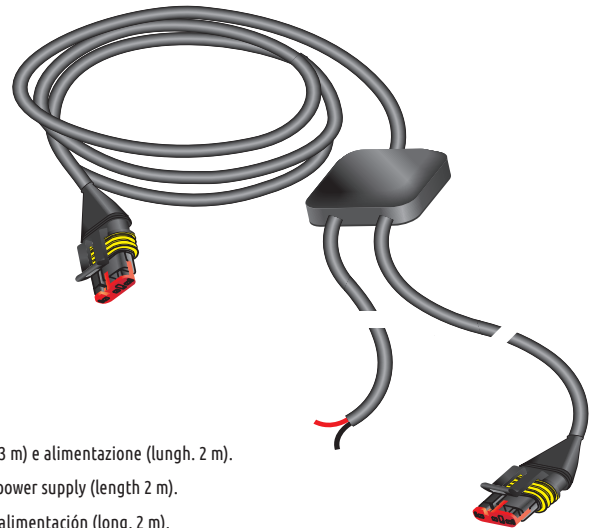

Fornito completo di cavo di collegamento (lung. 3 m) e alimentazione (lung. 2 m).  
 Supplied with connection cable (length 3 m) and power supply (length 2 m).  
 Suministrado con cable de conexión (long. 3 m) y alimentación (long. 2 m).

**Sensore di pressione**  
**Pressure sensor**  
**Sensor de presión**



COD. / CODE / CÓD.	Tipo / Type / Tipo
<b>466 113.200</b>	0-20 bar / 0-290 PSI
<b>466 113.500</b>	0-50 bar / 0-720 PSI

**Prolunghe**  
**Extension cables**  
**Prolongación**



COD. / CODE / CÓD.	Descrizione / Description / Descripción	Poli / Poles / Polos
<b>466 553.220</b>	Prolunga per sensori lungh. 3 m Sensor extension cable length 3 m Prolongación para sensores long. 3 m	3
<b>466 553.230</b>	Prolunga per sensori lungh. 5 m Sensor extension cable length 5 m Prolongación para sensores long. 5 m	3

# 4668 - 4669

## ACCESSORI PER SCATOLE DI COMANDO ACCESSORIES FOR CONTROL BOXES ACCESORIOS PARA CAJAS DE MANDO

C113

Kit portamanometro completo di manometro per scatole di comando serie **4668** e **4669**. Grazie agli appositi inserti e all'attacco a forchetta, è possibile posizionare il kit sopra o sul lato sinistro delle scatole della serie 4669 e sopra alle scatole di comando serie 4668.

Pressure gauge box kit complete with pressure gauge for control boxes series **4668** and **4669**. Suitable inserts and a fork coupling enable this box to be positioned on the top or on the left side of the boxes series 4669 and on top of control boxes series 4668.

Kit caja porta manómetro con manómetro para cajas de mando series **4668** y **4669**. Gracias a los específicos insertos y a la toma de horquilla, es posible posicionarla arriba o en el lado izquierdo de las cajas de la serie 4669 y sobre las cajas de mando serie 4668.



COD. KIT KIT CODE CÓD. KIT	Manometro incluso (cod.*) Pressure gauge included (code*) Manómetro incluido (cod.*)	Scala Dial Escala (bar)	Class	Quadrante Dial Esfera	Tipo Type Tipo
<b>4668 12</b>	909010	0 ÷ 25	2.5	<b>a</b>	Standard
<b>4668 13</b>	909040	0 ÷ 40	2.5	<b>b</b>	
<b>4668 14</b>	909060	0 ÷ 60	2.5	<b>b</b>	
<b>4668 22</b>	9170525	0 ÷ 5/25	1.6	<b>c</b>	Isometric
<b>4668 24</b>	9172060	0 ÷ 20/60	1.6	<b>c</b>	

### Quadrante - Dial - Esfera

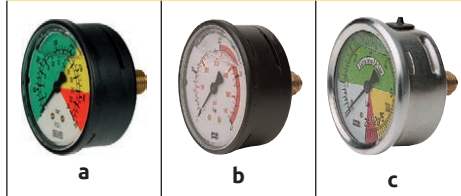

\* Il manometro è incluso nel codice del Kit. Manometri di ricambio nel capitolo

\* The pressure gauge is included in the kit part no. Spare pressure gauges in chapter

\* El manómetro está incluido en el código del Kit. Manómetros de repuesto en el capítulo

**ASSORTED ITEMS**



Fornito completo di tubo rilsan (lung. 6 m), raccordi rapidi e giunto di separazione.

Supplied with Rilsan hose (length 6 m), quick fittings and separation joint.

Suministrado con tubo rilsan (long. 6 m), acoples rápidos y unión de separación.

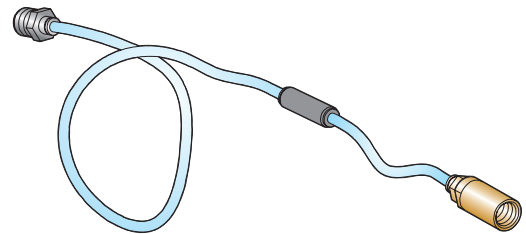

### Kit illuminatore per scatola portamanometro serie 4668 - 4669

- Applicabile alla scatola portamanometro per illuminare la scala in condizioni di lavoro notturno.
- Luce LED a basso assorbimento.
- Può essere posizionato nel punto preferito per adattarsi al montaggio della scatola di comando.
- Cavo di alimentazione 2 metri.
- Completo di viti di fissaggio.

### Light kit for pressure gauge box series 4668 - 4669

- Applicable to pressure gauge box to light up the scale during night job.
- Low absorption LED light.
- It can be positioned at any requested point ready for control box assembly.
- 2-meter power cable.
- Complete with fastening screws.

### Kit de iluminación para caja portamanómetro serie 4668 - 4669

- Applicable en la caja portamanómetro para iluminar la escalera en condiciones de trabajo nocturno.
- Luz LED de baja absorción.
- Se puede posicionar en el punto preferido para adaptarse al montaje de la caja de mando.
- Cable de alimentación 2 metros.
- Con tornillos de fijación.



COD.  
CODE  
CÓD.

**466800.500**





Orion Multiflow è un flussometro elettromagnetico a 4 canali per monitoraggio sistemi di distribuzione liquido.

Il flussometro è dotato di una porta A-net, tramite la quale può collegarsi in rete ad altri flussometri per monitorare oltre 100 linee tramite un unico cablaggio.

#### APPLICAZIONE TIPICA

Orion Multiflow è stato progettato per i sistemi di distribuzione di fertilizzante liquido su seminatrici di precisione dove normalmente vengono usati dei sistemi meccanici di visualizzazione della portata di ogni singola linea.

#### VANTAGGI

- L'operatore verrà avvisato dal monitor in cabina di un malfunzionamento, potendosi così occupare delle altre operazioni.
- Completamente indipendente dalla viscosità del liquido.
- Non richiede manutenzione, non avendo parti meccaniche in movimento all'interno del liquido.
- I flussometri possono essere installati nel punto migliore per l'impianto, e non dove sono più visibili all'operatore.

Orion Multiflow is an electro-magnetic flowmeter with 4 channels designed to monitor liquid distribution systems.

The flowmeter is provided with a A-net port that allows its connection to the network with other flowmeters to monitor over 100 lines through a single wiring.

#### STANDARD APPLICATION

Orion Multiflow has been designed for liquid fertilizer distribution systems on precision seeders that usually feature mechanic systems to display the flowrate of each single line.

#### ADVANTAGES

- Operators are warned by the monitor in the cabin if there is any malfunction and are free to carry out other operations.
- It is completely independent from liquid viscosity.
- It is maintenance-free since there are no mechanical parts moving inside the fluid.
- The flowmeters can be installed in the positions that best suit system needs, rather than those dictated by visibility to operator.

Orion Multiflow es un medidor de caudal electro-magnético de 4 canales para monitoreo de sistemas de distribución líquido.

El medidor de caudal tiene un puerto A-net, a través del cual se puede conectar en red a otros medidores de caudal para monitorear más de 100 líneas a través de un cableado único.

#### APLICACIÓN TÍPICA

Orion Multiflow ha sido diseñado para los sistemas de distribución de fertilizante líquido en sembradoras de precisión, donde normalmente se usan sistemas mecánicos de visualización del caudal de cada línea.

#### VENTAJAS

- El operador será avisado por el monitor de la cabina si hay un funcionamiento incorrecto, pudiendo ocuparse también de las demás operaciones.
- Completamente independiente de la viscosidad del líquido.
- No requiere mantenimiento, por no tener partes mecánicas en movimiento dentro del líquido.
- Los medidores de caudal se pueden instalar en el mejor punto para el sistema y no donde sean más visibles para el operador.





### CARATTERISTICHE

- Portata 0,3-6,0 l/min per canale.
- Errore tipico 0,5% del fondoscala.
- Porta A-net per lettura portata e configurazione.
- 4 Uscite ad impulsi 0-12 Vdc con frequenza proporzionale alla portata
- Led per segnalazione stato di ogni singolo canale.
- Pressione di utilizzo fino a 20 bar (290 PSI).
- Assorbimento massimo 0,6A.
- Attacchi a forchetta T1.
- Collettore modulare per raccordo ingressi con attacco a forchetta T3.
- Sistema di fissaggio integrato brevettato: non necessita di tiranti di assemblaggio nè di staffe di supporto.

### FEATURES

- 0.3-6.0 l/min flowrate per channel.
- Typical error: 0.5% of full scale.
- A-net port for flowrate and configuration reading.
- Four 0-12 Vdc pulse outputs with frequency proportional to flowrate
- LED for status indication of each single channel.
- Operating pressure up to 20 bar (290 PSI).
- Maximum absorption of 0.6 A.
- T1 fork couplings.
- Modular manifold for each inlet fitting with T3 fork coupling.
- Patented integrated fixing system eliminates the need for retaining bolts or support brackets.

### CARACTERÍSTICAS

- Caudal 0,3-6,0 l/min por canal.
- Error típico 0,5% del fondo escala.
- Puerto A-net para lectura caudal y configuración.
- 4 Salidas de impulsos 0-12 Vcc con frecuencia proporcional al caudal.
- Led para señalización estado de cada canal.
- Presión de uso hasta 20 bar (290 PSI).
- Absorción máxima 0,6A.
- Tomas de horquilla T1.
- Colector modular para acople entradas con toma de horquilla T3.
- Sistema de fijación integrado patentado; no necesita tirantes de ensamblado ni sostenes de soporte.



Alimentazione e porta A-net.  
Power supply and A-net port.  
Alimentación y puerto A-net.



Ingressi T1.  
T1 Inputs.  
Entradas T1.

Segnali in frequenza.  
Frequency signals.  
Señales de frecuencia.

LED di stato.  
Status LED.  
LED de estado

Uscite T1.  
T1 outputs.  
Salidas T1.

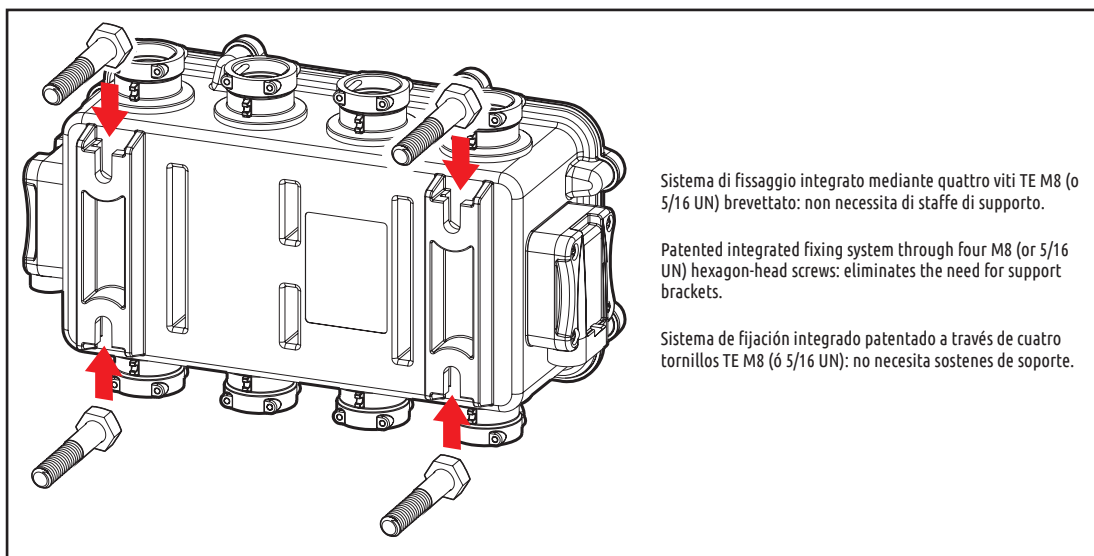

Sistema di fissaggio integrato mediante quattro viti TE M8 (o 5/16 UN) brevettato: non necessita di staffe di supporto.

Patented integrated fixing system through four M8 (or 5/16 UN) hexagon-head screws: eliminates the need for support brackets.

Sistema de fijación integrado patentado a través de cuatro tornillos TE M8 (ó 5/16 UN): no necesita sostenes de soporte.

SCHEMA DI INSTALLAZIONE  
E ACCESSORI

INSTALLATION DIAGRAM  
AND ACCESSORIES

ESQUEMA DE INSTALACIÓN  
Y ACCESORIOS

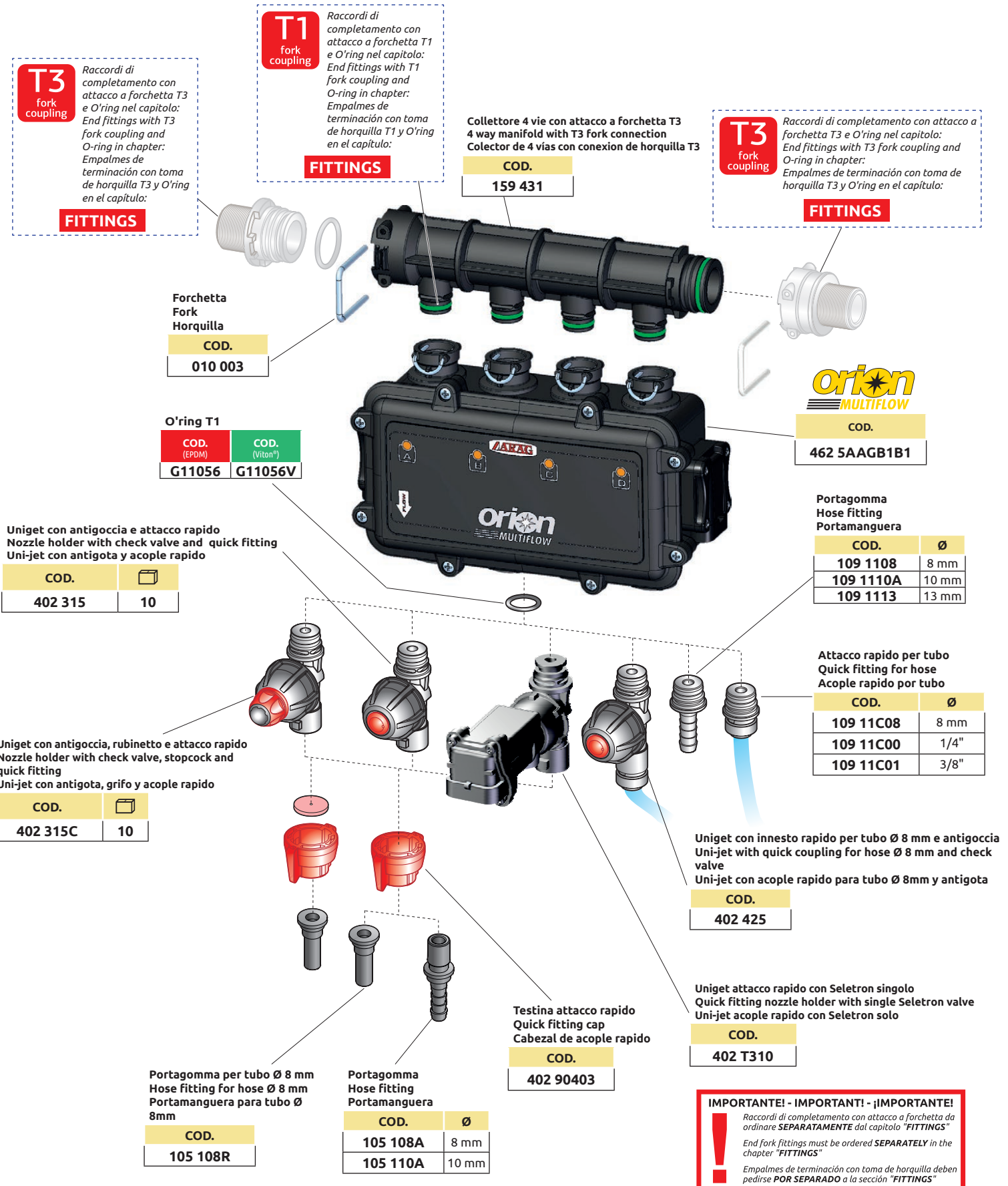

## SCHEMA DI APPLICAZIONE

Lo schema sottostante rappresenta un'applicazione tipica del Flussometro ORION MULTIFLOW in un sistema di distribuzione di fertilizzante liquido su seminatrice. I Flussometri ORION MULTIFLOW forniscono, tramite la linea A-net, i dati di portata di ogni singola linea di fertilizzante, permettendo così di monitorare dalla cabina il buon funzionamento del sistema.

L'unità di controllo (ECU) permette di collegare ulteriori sensori e valvole per la regolazione della portata. Le valvole Seletron, collegate tramite il A-net, permettono di parzializzare singolarmente le linee di distribuzione.

## APPLICATION DIAGRAM

The diagram below shows a typical application of the ORION MULTIFLOW Flowmeter in a liquid fertilizer distribution system on seeder.

ORION MULTIFLOW Flowmeters output, on A-net line, flowrate information of every single fertilizer line, thereby allowing the operator in the cabin to monitor system proper operation.

The control unit (ECU) allows connecting other flow control sensors and valves.

The Seletron valves, connected by A-net, allow system to individually control the distribution lines.

## ESQUEMA DE APLICACIÓN

El esquema de abajo representa una aplicación típica del medidor de caudal ORION MULTIFLOW en un sistema de distribución de fertilizante líquido en sembradora.

Los medidores de caudal ORION MULTIFLOW suministran, a través de la línea A-net, los datos de caudal de cada línea de fertilizante, permitiendo de esta manera monitorear desde la cabina el buen funcionamiento del sistema.

La unidad de control (ECU) permite conectar otros sensores y válvulas para la regulación del caudal.

Las válvulas Seletron, conectadas a través del A-net, permiten la división de manera individual de las líneas de distribución.

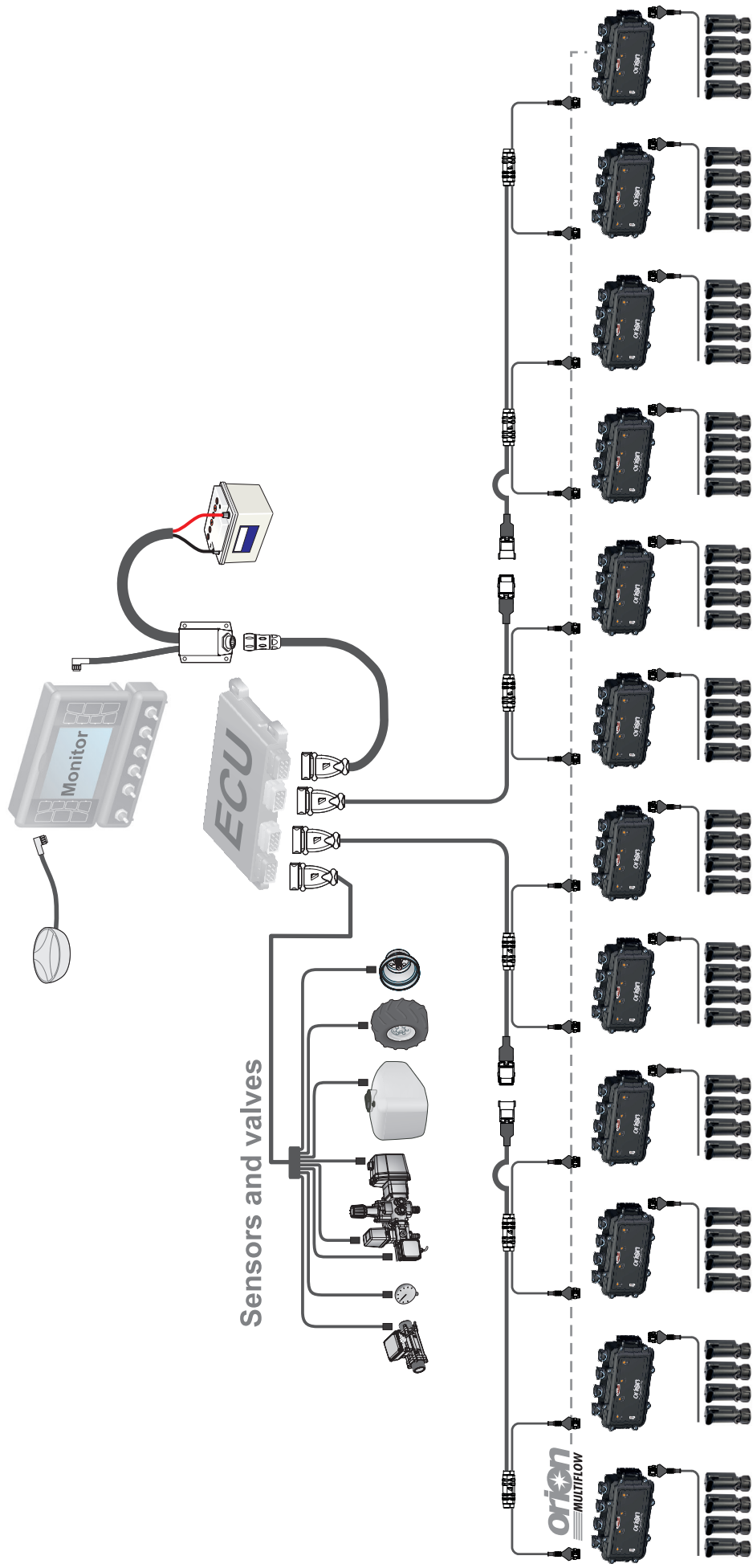

seletron

# VISUALIZZATORE DISPLAY VISUALIZADOR



**VISIO MULTIFLOW** è una versione del visualizzatore VISIO appositamente studiata per il collegamento al flussometro multicanale **ORION MULTIFLOW**. Grazie al software specifico e tramite una linea A-net, **VISIO MULTIFLOW** è in grado di visualizzare i dati di 4 flussometri per un totale di 16 canali.

**VISIO MULTIFLOW** is a version of VISIO display appositely designed to be connected to **ORION MULTIFLOW**, the multichannel flowmeter. Thanks to the specific software and by means of an A-net line, **VISIO MULTIFLOW** is able to display the data of 4 flowmeters for a total of 16 channels.

**VISIO MULTIFLOW** es una versión del visualizador VISIO específicamente estudiada para la conexión al caudalímetro multicanal **ORION MULTIFLOW**. Gracias al software específico y mediante una línea A-net, **VISIO MULTIFLOW** puede visualizar los datos de 4 caudalímetros por un total de 16 canales.



COD.  
CODE  
CÓD.

467 0611

Kit cavi per collegamento 2 flussometri  
Cables kit for 2 flowmeters  
Kit cables para 2 caudalímetros

14

COD.  
CODE  
CÓD.

4670611.510

- Collegamento A-net
- Possibilità di collegare fino a 4 flussometri ORION VISUALFLOW e di leggere i dati di 16 canali contemporaneamente
- Resistente agli agenti atmosferici
- Porta USB per trasferimento dati e aggiornamento software
- Allarmi visivi e sonori
- Software multilingua autoadattivo in base al numero di flussometri collegati
- Possibilità di impostare diverse unità di misura
- Display grafico retroilluminato

- A-net connection
- Possibility to connect up to 4 ORION VISUALFLOW flowmeters and able to read the data of 16 channels at the same time
- Resistant to weather conditions
- USB drive for data transfer and software update
- Visual and sound alarms
- Multi-language, self-adaptive software based on the number of flowmeters connected
- Possibility to set different units of measurement
- Backlit graphic display

- Conexión A-net
- Posibilidad de conexión de hasta 4 caudalímetros ORION VISUALFLOW y lectura de datos de 16 canales contemporaneamente
- Resistente a los agentes atmosféricos
- Puerto USB para transferencia de datos y actualización software
- Alarmas visuales y sonoras
- Software multilingua autoadaptable en base al número de caudalímetros conectados
- Posibilidad de programar diferentes unidades de medida
- Pantalla gráfica retroiluminada



SCHEMA DI INSTALLAZIONE E  
CONTENUTO DELLA CONFEZIONE

INSTALLATION DIAGRAM AND  
PACKAGE CONTENT

ESQUEMA DE INSTALACIÓN Y  
CONTENIDO DEL EMBALAJE

Schema di installazione per 1  
o 2 flussometri ORION MULTI-  
FLOW

Installation diagram for 1 or 2  
ORION MULTIFLOW flowmeters

Esquema de instalación para 1 o  
2 caudalímetros ORION MULTI-  
FLOW

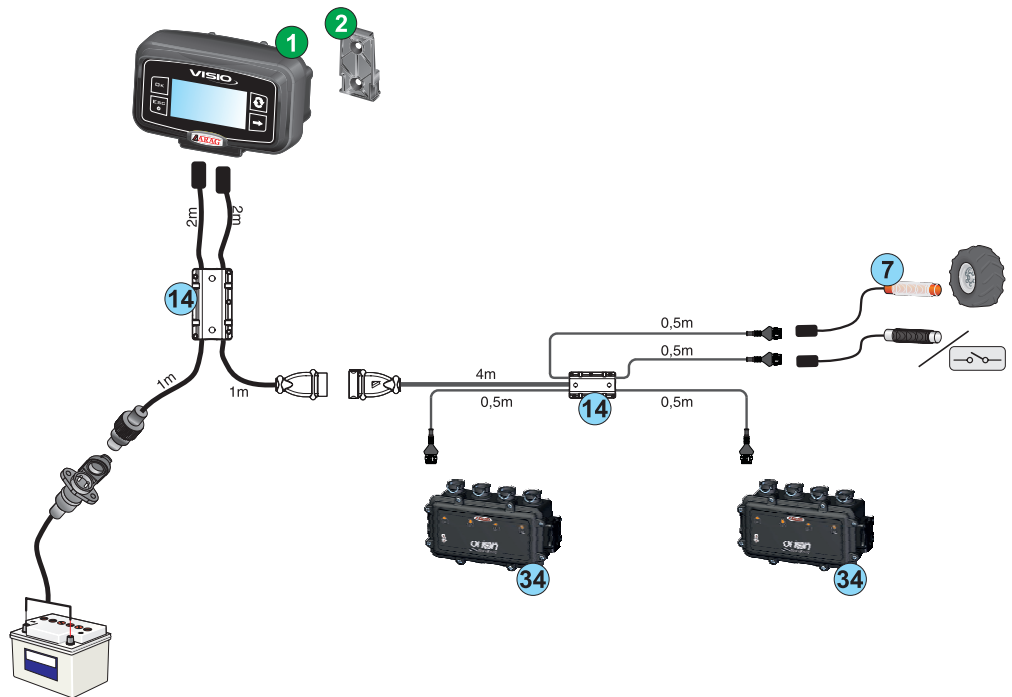

Schema di installazione fino a 4  
flussometri ORION MULTIFLOW

Installation diagram up to 4  
ORION MULTIFLOW flowmeters

Esquema de instalación hasta 4  
caudalímetros ORION MULTI-  
FLOW

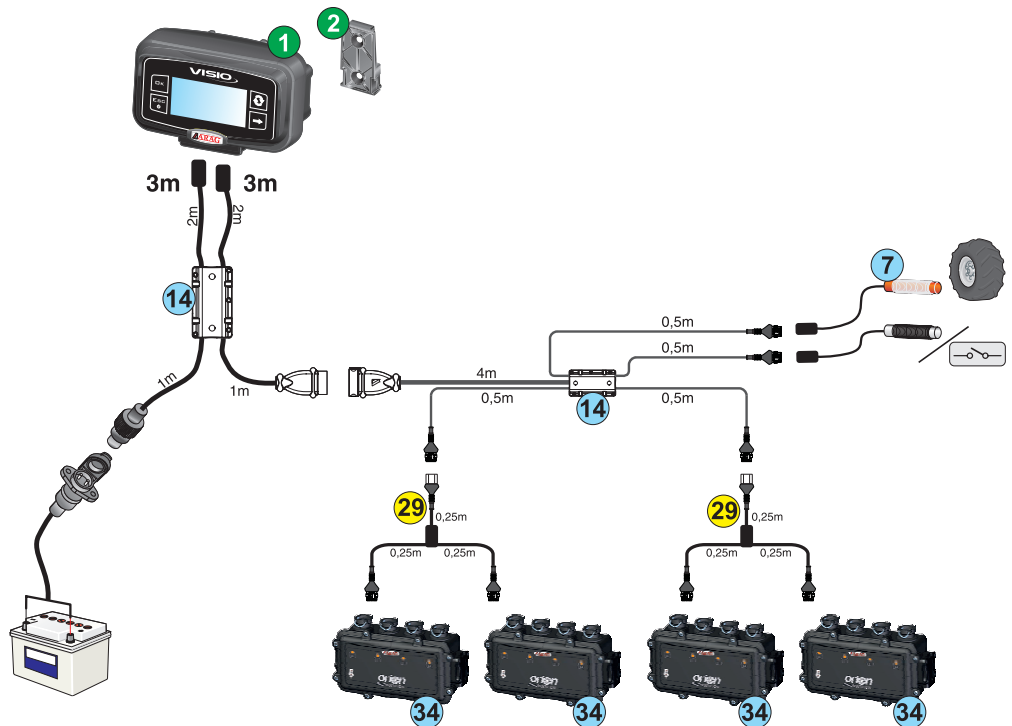

La confezione comprende:  
The package includes:  
El embalaje comprende:

1	VISIO MULTIFLOW
2	Staffa di supporto a baionetta Bayonet bracket Sostén de soporte de bayoneta
	Manuale di istruzioni User's guide Manual de instrucciones

Da ordinare a parte:  
To be order separately:  
Se debe pedir por separado:

7	Sensore di velocità induttivo con cavo 5 m Inductive speed sensor with 5 m cable Sensor inductivo de velocidad con cable 5 m	467100.086
	Sensore di velocità magnetico con cavo 5 m Magnetic speed sensor with 5 m cable Sensor magnético de velocidad con cable 5 m	467100.100
14	Kit cavi per VISIO MULTIFLOW VISIO MULTIFLOW cable kit Kit cables para VISIO MULTIFLOW	4670611.510
34	ORION MULTIFLOW	4625AAGB1B1

Accessori:  
Accessories:  
Accesorios:

29	Cavo splitter per 2 flussometri ORION MULTIFLOW Splitter cable for 2 ORION MULTIFLOW flowmeters Cable splitter para 2 caudalímetros ORION MULTIFLOW	46749000.160
----	---	--------------

# FLUSSOMETRI FLOWMETERS CAUDALIMETROS

Le tabelle seguenti possono aiutarvi nella scelta del flussometro adatto alle vostre esigenze, prendendo in considerazione le caratteristiche tecniche dei flussometri e quelle dei liquidi da misurare.

The following tables may help you to select the flowmeter suitable to your needs taking into account the technical features of the flowmeters and those of the fluids to be measured.

Las tablas siguientes le ayudarán en la selección del caudalímetro más adecuado para sus exigencias, teniendo en cuenta las características técnicas de los caudalímetros y de los líquidos que se medirán.

Caratteristiche Features Características	<i>orion2</i>	<i>orion2</i> VISUALFLOW	<i>orionX</i>	<i>orionX</i> VISUALFLOW	WOLF	DIGIWOLF
Tecnologia Technology Tecnología	Elettromagnetico Electromagnetic Electromagnético	Elettromagnetico Electromagnetic Electromagnético	Elettromagnetico Electromagnetic Electromagnético	Elettromagnetico Electromagnetic Electromagnético	A palette With paddles A paletas	A palette With paddles A paletas
Errore tipico sul fondoscala Typical full scale error Error típico en el fondo escala	0,5%	0,5%	0,5%	0,5%	1%	1%
Portata Flowrate Caudal	0,3 ÷ 800 l/min ■	0,3 ÷ 800 l/min ■	60 ÷ 2500 l/min	60 ÷ 2500 l/min	2,5 ÷ 800 l/min ■	2,5 ÷ 800 l/min ■
Pressione massima di utilizzo Maximum working pressure Presión máxima de uso	40 bar (580 PSI)	40 bar (580 PSI)	5 bar (72 PSI)	5 bar (72 PSI)	40 bar (580 PSI)	40 bar (580 PSI)
Segnale in uscita ad impulsi Pulse output signal Señal de salida de impulsos	●	●	●	●	●	●
Connessione Can-bus (A-net) Can-Bus (A-net) connection Conexión Can-bus (A-net)			●	●		
Display Display Pantalla		Numerico Numeric Numérica		Grafico Graphic Grafica		Grafico Graphic Grafica
Uscita per controllo riempimento Output for filling control Salida para control llenado		●		●		●
Tensione di alimentazione Power supply voltage Tensión de alimentación	11÷15 Vdc	11÷15 Vdc	9÷16 Vdc	9÷16 Vdc	4,5÷26 Vdc	4,5÷26 Vdc
Corrente max. assorbita Max. power absorption Absorción de corriente máx.	300 mA	300 mA	300 mA	450 mA	25 mA	25 mA
Manutenzione ridotta Low maintenance Mantenimiento reducido	●	●	●	●		
Funzione di pulizia elettronica dei depositi conduttivi Electronic cleaning of conductive deposits Función de limpieza electrónica de los depósitos conductores			●	●		
Manutenzione facilitata Facilitated maintenance Fácil mantenimiento					●	●

Campo di applicazione Application field Campo de aplicación	<i>orion2</i>	<i>orion2</i> VISUALFLOW	<i>orionX</i>	<i>orionX</i> VISUALFLOW	WOLF	DIGIWOLF
Liquidi con viscosità diverse Fluids with different viscosities Líquidos con viscosidades distintas	●	●	●	●	○	○
Liquidi corpi in sospensione Fluids with suspended particles Líquidos cuerpos en suspensión	●	●	●	●	○	○
Liquidi non conduttivi Non-conductive fluids Líquidos no conductores	—	—	—	—	●	●
Soluzioni o miscele che possono lasciare depositi conduttivi (solfato di rame, zolfo, ecc.) Solutions and mixes that can leave conductive deposits (copper sulfate, sulfur, etc.) Disoluciones o mezclas que pueden dejar depósitos conductores (sulfato de cobre, azufre, etc.)	—	—	○	○	●	●
Moto con elevata turbolenza Motion with high turbulence Movimiento con turbulencia elevada	●	●	●	●	○	○

### Legenda - Legend - Leyenda

●	Consigliato Recommended Recomendado	○	Non consigliato Not recommended No recomendado	—	Non adatto Not suitable No adecuado	■	a seconda del modello according to the version según la version
---	---	---	--	---	---	---	---

### Flussometro elettromagnetico ORION 2

#### Vantaggi

- Assenza di organi meccanici in movimento
- Insensibilità alla densità ed alla viscosità del fluido
- Bassa sensibilità alle turbolenze
- Elevata precisione
- Ridotta manutenzione

#### Caratteristiche

- Errore tipico 0,5% del fondoscala
- Pressione di utilizzo fino a 40 bar
- Tensione di alimentazione 11÷15 Vdc
- Uscita ad impulsi 0-12 Vdc con frequenza proporzionale alla portata
- Consumo massimo 300 mA
- Emissione di segnale solo in presenza di fluido in movimento
- Attacchi flangiati
- Parti a contatto con il fluido in polipropilene e acciaio Inox 316

### ORION 2 electro-magnetic flow meter

#### Advantages

- No mechanical moving parts inside the pipe
- Performances independent from fluid density and viscosity
- Low sensitivity to turbulence
- High precision
- Low maintenance

#### Characteristics

- Typical error: 0,5% full scale
- Working pressure: up to 40 bar
- Power supply: 11 to 15 Vdc
- 0-12 Vdc pulse output with frequency proportional to rate
- Max consumption: 300 mA
- Output only by flowing fluid
- Flanged fittings
- Parts in contact with fluid made of polypropylene and Stainless Steel 316

### Caudalimetro electro-magnético ORION 2

#### Ventajas

- Sin elementos mecánicos en movimiento
- Funcionamiento independiente de la densidad y de la viscosidad del fluido
- Baja sensibilidad a las turbulencias
- Elevada precisión
- Reducido mantenimiento

#### Características

- Error límite 0,5% del fondo escala
- Presión de trabajo hasta 40 bar
- Tensión de alimentación 11÷15 Vcc
- Salida a impulsos 0-12 Vcc con frecuencia proporcional al caudal
- Consumo máximo 300 mA
- Transmisión de la señal solo en presencia de fluido en movimiento
- Conexión de brida
- Componentes en contacto con el fluido en polipropileno y acero Inox 316





I nuovi ORION 2 sono dotati di connettore di collegamento a tenuta integrato nel corpo e di LED di segnalazione dello stato di funzionamento.

The new ORION 2 are equipped with a sealed connector integrated in the body and with operation status LED.

Los nuevos ORION 2 están dotados de conector de conexión hermética integrado al cuerpo y de LED de señalización del estado de funcionamiento.



COD. CODE CÓD.							Passaggi interni Internal passages Pasos internos	Impulsi Pulses Pulsos		Per valvole For valves Para válvulas
	lt/1'	US GPM	bar	PSI	bar	PSI		mm	pls/l	
46211AG0000	0,3÷6	0.08÷1.6	40	580	0,3	4	4	6000	22710	series 863 463
46211A00000	0,5÷10	0.13÷2.6	40	580	0,3	4	5	6000	22710	
46211A10000	1÷20	0.3÷5	40	580	0,3	4	7	3000	11355	
46211A20000	2,5÷50	0.6÷13	40	580	0,5	7	10	1200	4542	
46211A30000	5÷100	1.3÷26	40	580	0,5	7	14	600	2271	
46211A40000	10÷200	2.6÷53	40	580	0,5	7	18,5	300	1135	
46221A40000	10÷200	2.6÷53	20	290	0,5	7	18,5	300	1135	series 873 473
46221A50000	20÷400	5÷106	20	290	0,2	3	28	150	568	
46221A60000	30÷600	8÷158	20	290	0,5	7	28	100	378	
46221A70000	40÷800	10÷211	20	290	0,5	7	28	75	284	

### Cavo di alimentazione Feeding cable Cable de alimentación



COD. CODE CÓD.	Poli Poles Polos	mt	per for para
4621AA10000.100	3	3	ORION

**Flussometro elettromagnetico ORION 2**
**Vantaggi**

- Assenza di organi meccanici in movimento
- Insensibilità alla densità ed alla viscosità del fluido
- Bassa sensibilità alle turbolenze
- Elevata precisione
- Ridotta manutenzione

**Caratteristiche**

- Errore tipico 0,5% del fondoscala
- Pressione di utilizzo fino a 40 bar
- Tensione di alimentazione 11÷15 Vdc
- Uscita ad impulsi 0-12 Vdc con frequenza proporzionale alla portata
- Consumo massimo 300 mA
- Emissione di segnale solo in presenza di fluido in movimento
- Disponibile con attacchi filettati o flangiati
- Attacchi filettati in Nylon® rinforzato con fibra di vetro (20 bar) o ottone (40 bar)
- Parti a contatto con il fluido in polipropilene e acciaio Inox 316

**ORION 2 electro-magnetic flow meter**
**Advantages**

- No mechanical moving parts inside the pipe
- Performances independent from fluid density and viscosity
- Low sensitivity to turbulence
- High precision
- Low maintenance

**Characteristics**

- Typical error: 0,5% full scale
- Working pressure: up to 40 bar
- Power supply: 11 to 15 Vdc
- 0-12 Vdc pulse output with frequency proportional to rate
- Max consumption: 300 mA
- Output only by flowing fluid
- Available with threaded or flanged fittings
- Threaded fittings in fiber glass reinforced Nylon (20 bar) or brass (40 bar)
- Parts in contact with fluid made of polypropylene and Stainless Steel 316

**Caudalimetro electro-magnético ORION 2**
**Ventajas**

- Sin elementos mecánicos en movimiento
- Funcionamiento independiente de la densidad y de la viscosidad del fluido
- Baja sensibilidad a las turbulencias
- Elevada precisión
- Reducido mantenimiento

**Características**

- Error límite 0,5% del fondo escala
- Presión de trabajo hasta 40 bar
- Tensión de alimentación 11÷15 Vcc
- Salida a impulsos 0-12 Vcc con frecuencia proporcional al caudal
- Consumo máximo 300 mA
- Transmisión de la señal solo en presencia de fluido en movimiento
- Disponible con conexiones de rosca o de brida
- Conexiones de rosca en Nylon reforzadas con fibra de vidrio (20 bar) o en latón (40 bar)
- Componentes en contacto con el fluido en polipropileno y acero Inox 316

bar  
20  
290  
PSI

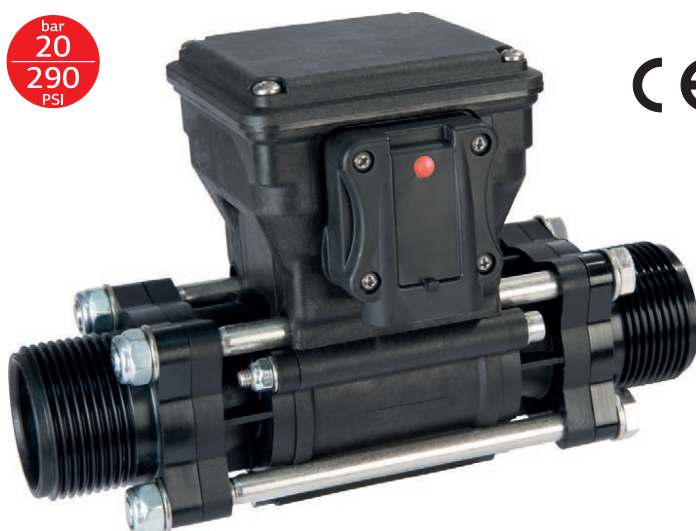

bar  
40  
580  
PSI

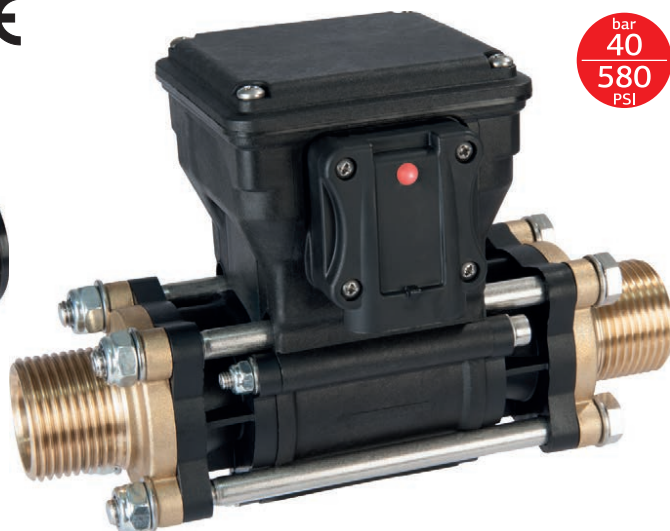

COD. CODE CÓD.							F BSP	Passaggi interni Internal passages Pasos internos mm	Impulsi Pulses Pulsos	
	lt/1'	US GPM	bar	PSI	bar	PSI			pls/l	pls/GAL
46211AG1313	0,3÷6	0.08÷1.6	20	290	0,3	4	G 3/4	4	6000	22710
46211AG3333	0,3÷6	0.08÷1.6	40	580	0,3	4	G 3/4	4	6000	22710
46211A01313	0,5÷10	0.13÷2.6	20	290	0,3	4	G 3/4	5	6000	22710
46211A03333	0,5÷10	0.13÷2.6	40	580	0,3	4	G 3/4	5	6000	22710
46211A11313	1÷20	0.3÷5	20	290	0,3	4	G 3/4	7	3000	11355
46211A13333	1÷20	0.3÷5	40	580	0,3	4	G 3/4	7	3000	11355
46211A21313	2,5÷50	0.6÷13	20	290	0,5	7	G 3/4	10	1200	4542
46211A23333	2,5÷50	0.6÷13	40	580	0,5	7	G 3/4	10	1200	4542
46211A31414	5÷100	1.3÷26	20	290	0,5	7	G 1	14	600	2271
46211A33434	5÷100	1.3÷26	40	580	0,5	7	G 1	14	600	2271
46211A41414	10÷200	2.6÷53	20	290	0,5	7	G 1	18,5	300	1135
46211A43434	10÷200	2.6÷53	40	580	0,5	7	G 1	18,5	300	1135
46211A41515	10÷200	2.6÷53	20	290	0,5	7	G 1 1/4	18,5	300	1135
46221A51515	20÷400	5÷106	20	290	0,2	3	G 1 1/4	28	150	568
46221A51616	20÷400	5÷106	20	290	0,2	3	G 1 1/2	28	150	568
46221A61616	30÷600	8÷158	20	290	0,5	7	G 1 1/2	28	100	378
46221A61717	30÷600	8÷158	20	290	0,5	7	G 2	28	100	378
46221A71717	40÷800	10÷211	20	290	0,5	7	G 2	28	75	284

**Cavo di alimentazione  
Feeding cable  
Cable de alimentación**

COD.  
CODE  
CÓD.

4621AA10000.100



Poli  
Poles  
Polos

mt

per  
for  
para

3

3

ORION/ORION 2



### Flussometro elettromagnetico ORION 2 VISUAL FLOW

#### Vantaggi

- Assenza di organi meccanici in movimento
- Insensibilità alla densità ed alla viscosità del fluido
- Bassa sensibilità alle turbolenze
- Elevata precisione
- Ridotta manutenzione

#### Caratteristiche

- Visualizzazione istantanea della portata
- Visualizzazione liquido erogato o caricato in cisterna
- Impostazione della quantità di liquido da caricare in cisterna
- Azzeramento del totalizzatore del liquido erogato
- Unità di misura in litri o US Gallons
- Errore tipico 0,5% - del fondoscala  $\pm 1$  digit
- Pressione di utilizzo fino a 40 bar
- Tensione di alimentazione 11÷15 Vdc
- Uscita ad impulsi 0-12 Vdc con frequenza proporzionale alla portata
- Consumo massimo 300 mA
- Emissione di segnale solo in presenza di fluido in movimento
- Disponibile con attacchi filettati in Nylon® rinforzato con fibra di vetro (20 bar) o ottone (40 bar)
- Parti a contatto con il fluido in polipropilene e acciaio Inox 316

### ORION 2 VISUAL FLOW electro-magnetic flow meter

#### Advantages

- No mechanical moving parts inside the pipe
- Performances independent from fluid density and viscosity
- Low sensitivity to turbulence
- High precision
- Low maintenance

#### Characteristics

- Instant flow display
- Total delivered (or filled) quantity display
- Set-up quantity to be filled
- Re-set total delivered quantity
- Unit of measure: litres or US Gallons
- Typical error: 0,5% - full scale  $\pm 1$  digit
- Working pressure: up to 40 bar
- Power supply: 11 to 15 Vdc
- 0-12 Vdc pulse output with frequency proportional to rate
- Max consumption: 300 mA
- Output only by flowing fluid
- Available c/w threaded fittings in fiber glass reinforced Nylon (20 bar) or brass (40 bar)
- Parts in contact with fluid made of polypropylene and Stainless Steel 316

### Caudalimetro electro-magnético ORION 2 VISUAL FLOW

#### Ventajas

- Sin elementos mecánicos en movimiento
- Funcionamiento independiente de la densidad y de la viscosidad del fluido
- Baja sensibilidad a las turbulencias
- Elevada precision
- Reducido mantenimiento

#### Características

- Visualización instantánea del caudal
- Visualización del líquido pulverizado o cargado al tanque
- Ingreso de la cantidad de líquido a cargar en el tanque
- Puesta a cero del totalizador del líquido pulverizado
- Unidad de medida en litros o galones
- Error límite 0,5% - plena escala  $\pm 1$  digit
- Presión de trabajo hasta 40 bar
- Tensión de alimentación 11÷15 Vcc
- Salida a impulsos 0-12 Vcc con frecuencia proporcional al caudal
- Consumo máximo 300 mA
- Transmisión de la señal solo en presencia de fluido en movimiento
- Disponible con conexiones de rosca en Nylon reforzadas con fibra de vidrio (20 bar) o en latón (40 bar)
- Componentes en contacto con el fluido en polipropileno y acero Inox 316



#### Cavo di alimentazione Feeding cable Cable de alimentación



COD. CODE CÓD.	Poli Poles Polos	mt	per for para
4622BA5000.100	4	3	ORION 2 VISUAL FLOW

COD. CODE CÓD.	F		F		Passaggi interni Internal passages Pasos internos mm	Impulsi Pulses Pulsos				
	lt/1'	US GPM	bar	PSI		pls/l	pls/GAL			
46212AG1313	0,3÷6	0.08÷1.6	20	290	0,3	4	G 3/4	4	6000	22710
46212AG3333	0,3÷6	0.08÷1.6	40	580	0,3	4	G 3/4	4	6000	22710
46212A01313	0,5÷10	0.13÷2.6	20	290	0,3	4	G 3/4	5	6000	22710
46212A03333	0,5÷10	0.13÷2.6	40	580	0,3	4	G 3/4	5	6000	22710
46212A11313	1÷20	0.3÷5	20	290	0,3	4	G 3/4	7	3000	11355
46212A13333	1÷20	0.3÷5	40	580	0,3	4	G 3/4	7	3000	11355
46212A21313	2,5÷50	0.6÷13	20	290	0,5	7	G 3/4	10	1200	4542
46212A23333	2,5÷50	0.6÷13	40	580	0,5	7	G 3/4	10	1200	4542
46212A31414	5÷100	1.3÷26	20	290	0,5	7	G 1	14	600	2271
46212A33434	5÷100	1.3÷26	40	580	0,5	7	G 1	14	600	2271
46212A41414	10÷200	2.6÷53	20	290	0,5	7	G 1	18,5	300	1135
46212A43434	10÷200	2.6÷53	40	580	0,5	7	G 1	18,5	300	1135
46212A41515	10÷200	2.6÷53	20	290	0,5	7	G 1 1/4	18,5	300	1135
46222A51616	20÷400	5÷106	20	290	0,2	3	G 1 1/2	28	150	568
46222A61616	30÷600	8÷158	20	290	0,5	7	G 1 1/2	28	100	378
46222A61717	30÷600	8÷158	20	290	0,5	7	G 2	28	100	378
46222A71717	40÷800	10÷211	20	290	0,5	7	G 2	28	75	284

## Flussometro elettromagnetico ORION X

### Vantaggi

- Assenza di organi meccanici in movimento
- Insensibilità alla densità ed alla viscosità del fluido
- Bassa sensibilità alle turbolenze
- Pulizia elettronica dei depositi conduttivi
- Elevata precisione
- Ridotta manutenzione

### Caratteristiche

- Errore tipico 0,5% del fondoscala.
- Pressione di utilizzo Max 5 bar (72 PSI).
- Portata fino a 2500 l/min (660 US GPM).
- Tensione di alimentazione 9÷16 Vdc.
- Uscita ad impulsi 0-12 Vdc con frequenza proporzionale alla portata.
- Collegamento A-net (Canbus).
- Emissione di segnale solo in presenza di fluido in movimento.
- Led di stato funzionamento
- Consumo massimo 300 mA.
- Attacchi T9 femmina (75 mm / 3").
- Parti a contatto con il fluido in Nylon® caricato fibra vetro e acciaio Inox AISI 316.

## ORION X electromagnetic flowmeter

### Advantages

- No mechanical moving parts inside the pipe
- Performances independent from fluid density and viscosity
- Low sensitivity to turbulence
- Electronic cleaning of conductive deposits
- High precision
- Low maintenance

### Characteristics

- Typical error: 0,5% full scale
- Working pressure: up to 5 bar (72 PSI)
- Flowrate up to 2500 l/min (660 US GPM).
- Power supply: 9 to 16 Vdc
- 0-12 Vdc pulse output with frequency proportional to rate
- A-net (Can-Bus) connection.
- Output only by flowing fluid
- Operating status LED
- Max consumption: 300 mA
- Female T9 connections (75 mm / 3").
- Parts in contact with fluid are in Nylon® reinforced with fiberglass and AISI 316 stainless steel.

## Caudalímetro electromagnético ORION X

### Ventajas

- Sin elementos mecánicos en movimiento
- Funcionamiento independiente de la densidad y de la viscosidad del fluido
- Baja sensibilidad a las turbulencias
- Limpieza electrónica de los depósitos conductores
- Elevada precisión
- Reducido mantenimiento

### Características

- Error límite 0,5% del fondo escala
- Presión de trabajo hasta 5 bar (72 PSI)
- Caudal hasta 2500 l/min (660 US GPM).
- Tensión de alimentación 9÷16 Vcc
- Salida a impulsos 0-12 Vcc con frecuencia proporcional al caudal
- Conexión A-net (Can-bus).
- Transmisión de la señal solo en presencia de fluido en movimiento
- Led de estado funcionamiento.
- Consumo máximo 300 mA
- Empalmes T9 hembra (75 mm / 3").
- Partes en contacto con el líquido de Nylon® cargado con fibra de vidrio y acero inoxidable AISI 316.



**HI-FLOW: 2500 l/min**

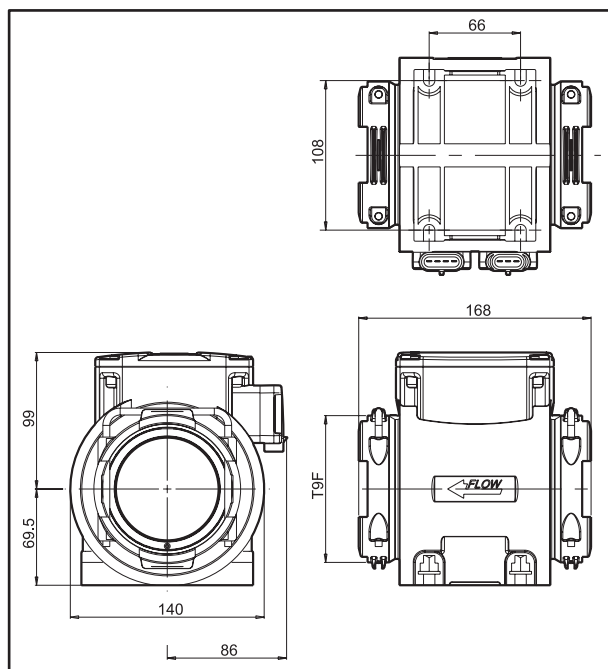

COD. CODE CÒD.	Attacco Connection Toma		Impulsi Pulses Pulsos
	lt/l'	US GPM	
4629 9A90	60÷2500	16÷660	T9 F
			bar   PSI
			5   72
			mm
			75
			pls/l   pls/GAL
			24   91

I flussometri della serie ORION X sono dotati di doppia porta di connessione per poter utilizzare CONTEMPORANEAMENTE l'uscita in frequenza e quella con protocollo A-net.

ORION X flowmeters are equipped with double connection port to SIMULTANEOUSLY use the frequency output and the one with A-net protocol.

Los caudalímetros de la serie ORION X cuentan con un doble puerto de conexión para poder utilizar CONTEMPORÁNEAMENTE la salida en frecuencia y la salida con protocolo A-net.



### Flussometro elettromagnetico ORION X

#### Vantaggi

- Assenza di organi meccanici in movimento
- Insensibilità alla densità ed alla viscosità del fluido
- Bassa sensibilità alle turbolenze
- Pulizia elettronica dei depositi conduttivi
- Elevata precisione
- Ridotta manutenzione
- Display grafico retroilluminato

#### Caratteristiche

- Errore tipico 0,5% del fondoscala.
- Pressione di utilizzo Max 5 bar (72 PSI).
- Portata fino a 2500 l/min (660 US GPM).
- Tensione di alimentazione 9÷16 Vdc.
- Uscita ad impulsi 0-12 Vdc con frequenza proporzionale alla portata.
- Collegamento A-net (Canbus).
- Uscita per comando valvola di riempimento
- Emissione di segnale solo in presenza di fluido in movimento.
- Led di stato funzionamento
- Consumo massimo 300 mA.
- Attacchi T9 femmina (75 mm / 3").
- Parti a contatto con il fluido in Nylon® caricato fibra vetro e acciaio Inox AISI 316.

### ORION X electromagnetic flowmeter

#### Advantages

- No mechanical moving parts inside the pipe
- Performances independent from fluid density and viscosity
- Low sensitivity to turbulence
- Electronic cleaning of conductive deposits
- High precision
- Low maintenance
- Graphic backlit display

#### Characteristics

- Typical error: 0,5% full scale
- Working pressure: up to 5 bar (72 PSI)
- Flowrate up to 2500 l/min (660 US GPM).
- Power supply: 9 to 16 Vdc
- 0-12 Vdc pulse output with frequency proportional to rate
- A-net (Can-Bus) connection.
- Output for filling valve control
- Output only by flowing fluid
- Operating status LED
- Max consumption: 300 mA
- Female T9 connections (75 mm / 3").
- Parts in contact with fluid are in Nylon® reinforced with fiberglass and AISI 316 stainless steel.

### Caudalímetro electromagnético ORION X

#### Ventajas

- Sin elementos mecánicos en movimiento
- Funcionamiento independiente de la densidad y de la viscosidad del fluido
- Baja sensibilidad a las turbulencias
- Limpieza electrónica de los depósitos conductores
- Elevada precisión
- Reducido mantenimiento
- Pantalla gráfica retroiluminada

#### Características

- Error límite 0,5% del fondo escala
- Presión de trabajo hasta 5 bar (72 PSI)
- Caudal hasta 2500 l/min (660 US GPM).
- Tensión de alimentación 9÷16 Vcc
- Salida a impulsos 0-12 Vcc con frecuencia proporcional al caudal
- Conexión A-net (Can-bus).
- Salida para mando válvula de llenado
- Transmisión de la señal solo en presencia de fluido en movimiento
- Led de estado funcionamiento.
- Consumo máximo 300 mA
- Empalmes T9 hembra (75 mm / 3").
- Partes en contacto con el líquido de Nylon® cargado con fibra de vidrio y acero inoxidable AISI 316.



**HI-FLOW: 2500 l/min**

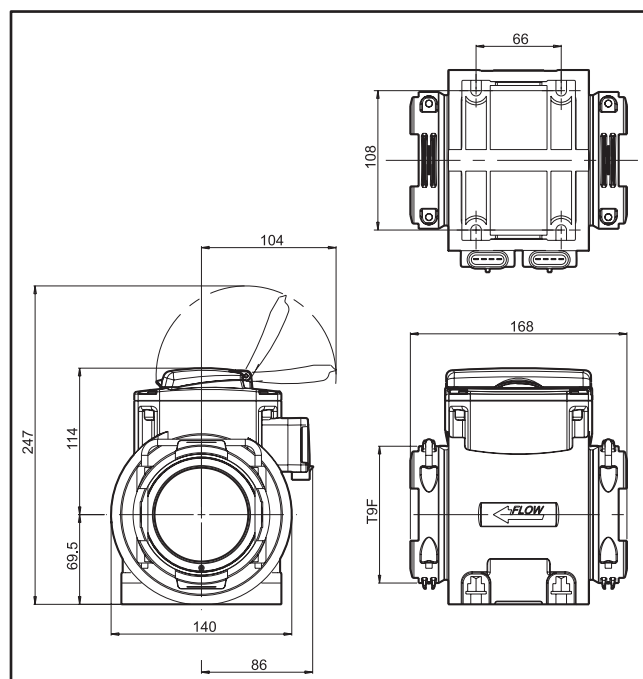

COD. CODE CÓD.	Attacco Connection Toma		Impulsi Pulses Pulsos
	lt/1'	US GPM	
<b>4629 9B90</b>	60÷2500	16÷660	T9 F

Passaggi interni Internal passages Pasos internos	Impulsi Pulses Pulsos	
		mm
75	24	91

**Flussometro elettromagnetico ORION X**

**Vantaggi**

- Assenza di organi meccanici in movimento
- Insensibilità alla densità ed alla viscosità del fluido
- Bassa sensibilità alle turbolenze
- Pulizia elettronica dei depositi conduttivi
- Elevata precisione
- Ridotta manutenzione

**Caratteristiche**

- Errore tipico 0,5% del fondoscala.
- Pressione di utilizzo Max 5 bar (72 PSI).
- Portata fino a 2500 l/min (660 US GPM).
- Tensione di alimentazione 9÷16 Vdc.
- Uscita ad impulsi 0-12 Vdc con frequenza proporzionale alla portata.
- Collegamento A-net (Canbus).
- Emissione di segnale solo in presenza di fluido in movimento.
- Led di stato funzionamento
- Consumo massimo 300 mA.
- Attacco a morsetto\* 3" Full Port.
- Parti a contatto con il fluido in Nylon® caricato fibra vetro e acciaio Inox AISI 316.

**ORION X electromagnetic flowmeter**

**Advantages**

- No mechanical moving parts inside the pipe
- Performances independent from fluid density and viscosity
- Low sensitivity to turbulence
- Electronic cleaning of conductive deposits
- High precision
- Low maintenance

**Characteristics**

- Typical error: 0,5% full scale
- Working pressure: up to 5 bar (72 PSI)
- Flowrate up to 2500 l/min (660 US GPM).
- Power supply: 9 to 16 Vdc
- 0-12 Vdc pulse output with frequency proportional to rate
- A-net (Can-Bus) connection.
- Output only by flowing fluid
- Operating status LED
- Max consumption: 300 mA
- 3" Full Port clamp\* connection.
- Parts in contact with fluid are in Nylon® reinforced with fiberglass and AISI 316 stainless steel.

**Caudalímetro electromagnético ORION X**

**Ventajas**

- Sin elementos mecánicos en movimiento
- Funcionamiento independiente de la densidad y de la viscosidad del fluido
- Baja sensibilidad a las turbulencias
- Limpieza electrónica de los depósitos conductores
- Elevada precisión
- Reducido mantenimiento

**Características**

- Error límite 0,5% del fondo escala
- Presión de trabajo hasta 5 bar (72 PSI)
- Caudal hasta 2500 l/min (660 US GPM).
- Tensión de alimentación 9÷16 Vcc
- Salida a impulsos 0-12 Vcc con frecuencia proporcional al caudal
- Conexión A-net (Can-bus).
- Transmisión de la señal solo en presencia de fluido en movimiento
- Led de estado funcionamiento.
- Consumo máximo 300 mA
- Toma de mordaza\* 3" Full Port.
- Partes en contacto con el líquido de Nylon® cargado con fibra de vidrio y acero inoxidable AISI 316.



**HI-FLOW: 2500 l/min**

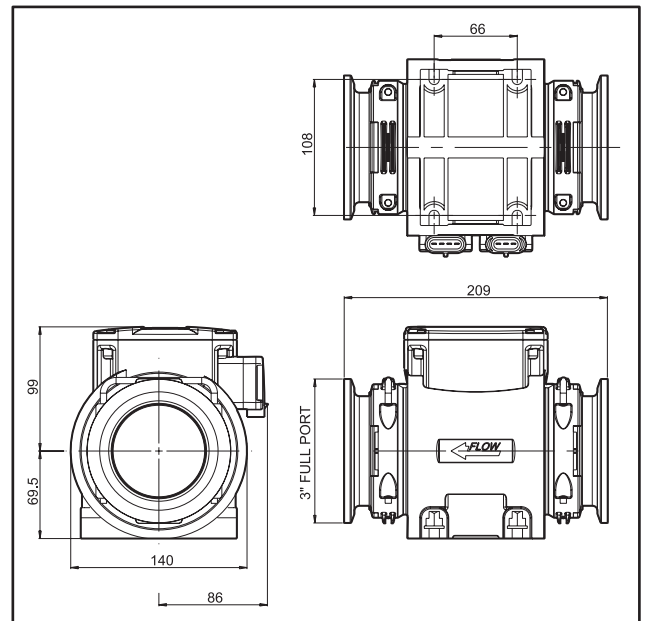

COD. CODE CÒD.	lt/1'	US GPM	Attacco Connection Toma	bar PSI	Passaggi interni Internal passages Pasos internos	Impulsi Pulses Pulsos
					mm	pls/l pls/GAL
<b>4629 9A91</b>	60÷2500	16÷660	3" Full Port*	5 72	75	24 91



\*: Compatible con attacchi tipo Banjo®, Hypro® e Bee Valve®.  
Suitable for use with Banjo®, Hypro® and Bee Valve® connections.  
Compatible con las conexiones tipo Banjo®, Hypro® y Bee Valve®.

**Kit morsetto di serraggio completo di vite**

**Kit of tightening clamp with screw**

**Kit mordaza de ajuste completa con tornillo**

COD. CODE CÒD.	F	Tipo Type Tipo		3 EPDM	3 Viton®
<b>1 10A00300</b>	3" Full port	NYLON®	10	<b>18109B.050</b>	<b>18129B.050</b>
<b>2 10A01300</b>	3" Full port	INOX	10	<b>18109B.050</b>	<b>18129B.050</b>

**NEW**

**Accessori da ordinare separatamente  
Accessories to order separately  
Accesorios a pedir por separado**



### Flussometro elettromagnetico ORION X

#### Vantaggi

- Assenza di organi meccanici in movimento
- Insensibilità alla densità ed alla viscosità del fluido
- Bassa sensibilità alle turbolenze
- Pulizia elettronica dei depositi conduttivi
- Elevata precisione
- Ridotta manutenzione
- Display grafico retroilluminato

#### Caratteristiche

- Errore tipico 0,5% del fondoscala.
- Pressione di utilizzo Max 5 bar (72 PSI).
- Portata fino a 2500 l/min (660 US GPM).
- Tensione di alimentazione 9÷16 Vdc.
- Uscita ad impulsi 0-12 Vdc con frequenza proporzionale alla portata.
- Collegamento A-net (Canbus).
- Uscita per comando valvola di riempimento
- Emissione di segnale solo in presenza di fluido in movimento.
- Led di stato funzionamento
- Consumo massimo 300 mA.
- Attacco a morsetto\* 3" Full Port.
- Parti a contatto con il fluido in Nylon® caricato fibra vetro e acciaio Inox AISI 316.

### ORION X electromagnetic flowmeter

#### Advantages

- No mechanical moving parts inside the pipe
- Performances independent from fluid density and viscosity
- Low sensitivity to turbulence
- Electronic cleaning of conductive deposits
- High precision
- Low maintenance
- Graphic backlit display

#### Characteristics

- Typical error: 0,5% full scale
- Working pressure: up to 5 bar (72 PSI)
- Flowrate up to 2500 l/min (660 US GPM).
- Power supply: 9 to 16 Vdc
- 0-12 Vdc pulse output with frequency proportional to rate
- A-net (Can-Bus) connection.
- Output for filling valve control
- Output only by flowing fluid
- Operating status LED
- Max consumption: 300 mA
- 3" Full Port clamp\* connection.
- Parts in contact with fluid are in Nylon® reinforced with fiberglass and AISI 316 stainless steel.

### Caudalímetro electromagnético ORION X

#### Ventajas

- Sin elementos mecánicos en movimiento
- Funcionamiento independiente de la densidad y de la viscosidad del fluido
- Baja sensibilidad a las turbulencias
- Limpieza electrónica de los depósitos conductores
- Elevada precisión
- Reducido mantenimiento
- Pantalla gráfica retroiluminada

#### Características

- Error límite 0,5% del fondo escala
- Presión de trabajo hasta 5 bar (72 PSI)
- Caudal hasta 2500 l/min (660 US GPM).
- Tensión de alimentación 9÷16 Vcc
- Salida a impulsos 0-12 Vcc con frecuencia proporcional al caudal
- Conexión A-net (Can-bus).
- Salida para mando válvula de llenado
- Transmisión de la señal solo en presencia de fluido en movimiento
- Led de estado funcionamiento.
- Consumo máximo 300 mA
- Toma de mordaza\* 3" Full Port.
- Partes en contacto con el líquido de Nylon® cargado con fibra de vidrio y acero inoxidable AISI 316.



**HI-FLOW: 2500 l/min**

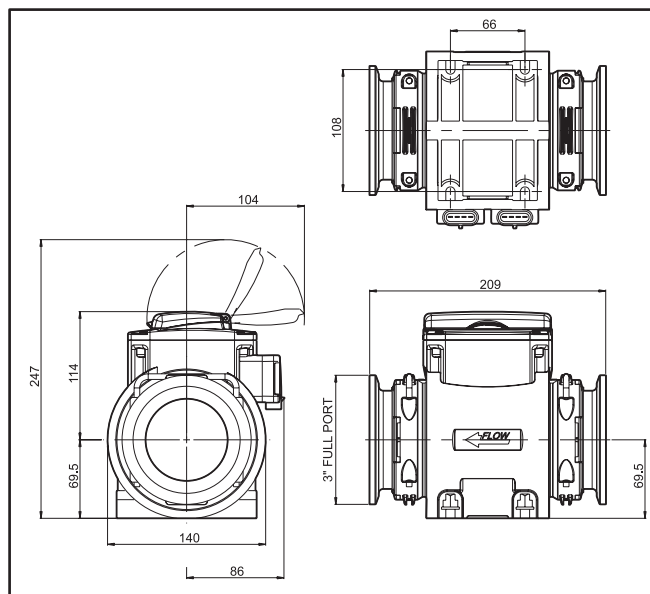

\*: Compatibile con attacchi tipo Banjo®, Hypro® e Bee Valve®.  
Suitable for use with Banjo®, Hypro® and Bee Valve® connections.  
Compatible con las conexiones tipo Banjo®, Hypro® y Bee Valve®.

COD. CODE CÓD.	Attacco Connection Toma		Passaggi interni Internal passages Pasos internos		Impulsi Pulses Pulsos			
	lt/1'	US GPM	bar	PSI	pls/l	pls/GAL		
<b>4629 9B91</b>	60÷2500	16÷660	3" Full Port*	5	72	75	24	91

### Kit morsetto di serraggio completo di vite

### Kit of tightening clamp with screw

### Kit mordaza de ajuste completa con tornillo

COD. CODE CÓD.	F	Tipo Type Tipo	10	3		3	
				EPDM	Viton®	10	10
<b>10A00300</b>	3" Full port	NYLON®	10	<b>18109B.050</b>	10	<b>18129B.050</b>	10
<b>10A01300</b>	3" Full port	INOX	10	<b>18109B.050</b>	10	<b>18129B.050</b>	10

**Accessori da ordinare separatamente  
Accessories to order separately  
Accesorios a pedir por separado**



**NEW**

## Flussometro a palette WOLF

### Vantaggi

- Alta precisione e ottimo rapporto prezzo/prestazioni
- Versioni con attacchi a forchetta per configurare a piacere le connessioni
- Versioni per integrazione nei gruppi di comando e con flange in ottone per alte pressioni
- LED indicatore di funzionamento
- Perno delle palette in zaffiro per ridurre al minimo gli attriti durante la rotazione e aumentare al massimo sensibilità e precisione
- Gruppo paletta con sistema "TWIST" per la pulizia o la sostituzione senza bisogno di attrezzi
- Sensore elettronico completamente sigillato e a tenuta stagna
- Gamma di portate da 2,5 a 800 l/min

### Caratteristiche

- Errore tipico 1% del fondoscala
- Pressione di utilizzo fino a 40 bar\*
- Tensione di alimentazione 4,5÷26 Vdc
- Uscita ad impulsi 0-12 Vdc con frequenza proporzionale alla portata
- Consumo massimo 25 mA
- Parti a contatto con il fluido in Nylon® rinforzato con fibra di vetro e Delrin®

\*: la pressione di utilizzo dipende dalla tipologia di attacco/raccordo scelto.

## WOLF paddle flow-meter

### Benefits

- Hi-precision and good price/performance ratio
- Variants with fork connectors for flexible connection layout
- Variants suitable for fitting into control units and equipped with hi-pressure brass flanges
- Operating status LED
- Sapphire paddle pin to minimize rotational friction and maximize sensitivity and accuracy
- Paddle assembly equipped with 'TWIST' system for either cleaning or replacing operations without the need of any tools
- Fully sealed and watertight electronic sensor
- Rates from 2.5 to 800 l/min

### Features

- Typical error 1% of full scale
- Operating pressure: up to 40 bars\*
- Power supply 4.5 to 26 Vdc
- 0-12 Vdc pulse output with frequency proportional to rate
- Max. consumption: 25 mA
- Parts in contact with the fluid are made of fiberglass and Delrin® reinforced Nylon

\*: operating pressure depends on selected connector/union.

## Caudalímetro de paletas WOLF

### Ventajas

- Alta precisión y excelente relación precio/prestaciones
- Versiones con empalmes con acople de horquilla para configurar las conexiones a gusto
- Versiones para integrar en los grupos de mando y con bridas de latón para altas presiones
- LED indicador de funcionamiento
- Perno de las paletas de zafiro para reducir al mínimo los roces durante la rotación y aumentar al máximo la sensibilidad y la precisión
- Grupo paleta con sistema "TWIST" para la limpieza o la sustitución sin necesidad de herramientas
- Sensor electrónico completamente sellado y hermético
- Caudales de 2,5 a 800 l/min.

### Características

- Error típico 1% del valor máximo
- Presión de uso hasta 40 bar\*
- Tensión de alimentación 4,5÷26 Vcc
- Salida a impulsos 0-12 Vcc con frecuencia proporcional al caudal
- Consumo máximo 25 mA
- Piezas en contacto con el líquido de Nylon reforzado con fibra de vidrio y Delrin®

\*: la presión de uso depende del tipo de empalme/racor elegido

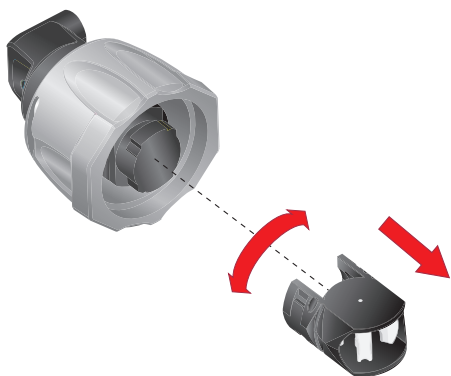

Il sistema "TWIST" è la peculiarità dei flussometri WOLF. Il reparto di Ricerca e Sviluppo di ARAG ha studiato un sistema di sgancio rapido, senza l'utilizzo di attrezzi, che permette la pulizia della paletta, solitamente soggetta a raccogliere i sedimenti dei prodotti chimici presenti nei liquidi utilizzati in agricoltura.

The "TWIST" system is the peculiar feature of WOLF flow meters. ARAG R&D department has designed a quick-release system that does not require any tools and allows paddle cleaning, which is important considering that paddle usually collects any sediments of the chemicals contained in the fluids used for agricultural purposes.

El sistema "TWIST" es la particularidad de los medidores de caudal WOLF. El sector de Investigación y Desarrollo de ARAG ha estudiado un sistema de desenganche rápido, sin necesidad de herramientas. Permite la limpieza de la paleta que habitualmente acumula los sedimentos de los productos químicos presentes en los líquidos usados en agricultura.



## Attacco a forchetta - Fork coupling - Acople de horquilla

COD. CODE CÓD.	Fork Coupling		Attacco Connection Toma	Ø Equiv.	P max		@ MAX.	
	l'/1'	US GPM			bar	PSI	bar	PSI
462 6305	5-100	1.3-26	T5 F	1" 1/4	20	290	1,5	22
462 6405	10-200	2.6-53	T5 F	1" 1/4	20	290	0,7	10
462 6406	10-200	2.6-53	T6 F	1" 1/2	12	174	0,7	10
462 6506	20-400	5-106	T6 F	1" 1/2	12	174	0,5	7
462 6707	40-800	10-210	T7 F	2"	7	130	0,3	4

**T5**  
fork  
coupling

**T6**  
fork  
coupling



**T7**  
fork  
coupling

Accessori di completamento nel capitolo:  
Accessories available in chapter:  
Accesorios de terminación en el capítulo:

**FITTINGS**





Flangia ottone filetto maschio - Male threaded brass flange - Brida de latón rosca macho

COD. CODE CÓD.			Attacco Connection Toma	P max			
	1/1'	US GPM		bar	PSI	bar	PSI
462 62A03	2.5-50	0.7-13	3/4" G	40	580	1,5	22
462 63A03	5-100	1.3-26	3/4" G	40	580	1,5	22
462 63A04	5-100	1.3-26	1" M	40	580	1,5	22
462 64A03	10-200	2.6-53	3/4" G	40	580	0,7	10
462 64A04	10-200	2.6-53	1" M	40	580	0,7	10





Flangiato per valvole 863 - Flanged for 863 valves - Embridado para válvulas 863

COD. CODE CÓD.			Attacco Connection Toma	P max			
	1/1'	US GPM		bar	PSI	bar	PSI
462 62A0	2.5-50	0.7-13	463	40	580	1,5	22
462 63A0	5-100	1.3-26	463	40	580	1,5	22
462 64A0	10-200	2.6-53	463	40	580	0,7	10



Attacco a forchetta T5 per gruppi di comando - T5 fork connector for control units  
Empalme con acople de horquilla T5 para grupos de mando

COD. CODE CÓD.			Attacco Connection Toma	Ø Equiv.	P max			
	1/1'	US GPM			bar	PSI	bar	PSI
462 6315	5-100	1.3-26	T5 F/M	1" 1/4	20	290	1,5	22
462 6415	10-200	2.6-53	T5 F/M	1" 1/4	20	290	0,7	10

**T5**  
fork  
coupling

Paletta di ricambio per flussometri WOLF  
Spare paddle for WOLF flow meters  
Paleta de repuesto para caudalímetros WOLF

COD / COD. / CODE

4626000.503



Cavo di alimentazione  
Feeding cable  
Cable de alimentación



COD. CODE CÓD.	Poli Poles Polos	mt	per for para
4621AA1000.100	3	3	ORION/WOLF

## Flussometro a palette con visualizzatore digitale DIGIWOLF

### Vantaggi

- Elevata precisione
- Display grafico multilingua programmabile
- Disponibile sia in versione con alimentazione esterna a batteria (12 Vdc) che con alimentazione interna a pile
- Coperchio di protezione del display con chiusura a scatto
- Corpo con attacchi a forchetta per configurare a piacere le connessioni
- Perno delle palette in zaffiro per ridurre al minimo gli attriti durante la rotazione e aumentare al massimo sensibilità e precisione
- Gruppo paletta con sistema "TWIST" per la pulizia o la sostituzione senza bisogno di attrezzi
- Sensore elettronico completamente sigillato e a tenuta stagna
- Portate da 10 a 800 l/min

### Caratteristiche

- Visualizzazione istantanea della portata (l/min)
- Visualizzazione liquido erogato
- Unità di misura in litri o US Gallons
- 2 totalizzatori con azzeramento indipendente
- Allarme programmabile soglia di flusso (min./max.)
- Procedura assistita di calibrazione della costante
- Errore tipico 1% del fondoscala
- Pressione di utilizzo fino a 20 bar\*
- Parti a contatto con il fluido in Nylon® rinforzato con fibra di vetro e Delrin®

\*: la pressione di utilizzo dipende dalla tipologia di attacco/raccordo scelto.

## Paddle flow-meter with DIGIWOLF digital display

### Benefits

- High accuracy
- Programmable multilingual graphic display
- Available either with external battery (12 Vdc) or inside cell power supply
- Display snap-on cover
- Body with fork connectors for flexible connection layout
- Sapphire paddle pin to minimize rotational friction and maximize sensitivity and accuracy
- Paddle assembly equipped with 'TWIST' system for either cleaning or replacing operations without the need of any tools
- Fully sealed and watertight electronic sensor
- Rates from 10 to 800 l/min

### Features

- Instant rate display (l/min)
- Supplied fluid display
- Unit of measurement: liters or US Gallons
- 2 separately resettable counters
- Programmable flow threshold alarm (min./max.)
- Assisted constant setting procedure
- Characteristic mistake: 1% of the full scale
- Operating pressure: up to 20 bars\*
- Parts in contact with the fluid are made of fiberglass and Delrin® reinforced Nylon

\*: operating pressure depends on selected connector/union.

## Caudalímetro de paletas con visualizador digital DIGIWOLF

### Ventajas

- Alta precisión
- Pantalla gráfica multidioma programable
- Disponible tanto con alimentación con batería externa (12 Vcc) como con pilas internas
- Tapa de protección de la pantalla con cierre de resorte
- Cuerpo con empalmes con acople de horquilla para configurar las conexiones a gusto
- Perno de las paletas de zafiro para reducir al mínimo los roces durante la rotación y aumentar al máximo la sensibilidad y la precisión
- Grupo paleta con sistema "TWIST" para la limpieza o la sustitución sin necesidad de herramientas
- Sensor electrónico completamente sellado y hermético
- Caudales de 10 a 800 l/min

### Características

- Visualización instantánea del caudal (l/min)
- Visualización líquido suministrado
- Unidad de medida en litros o US Gallons
- 2 totalizadores con puesta a cero independiente
- Alarma programable umbral de flujo (mín./máx.)
- Procedimiento asistido de calibración de la constante
- Error típico 1% del valor máximo
- Presión de uso hasta 20 bar\*
- Piezas en contacto con el líquido de Nylon reforzado con fibra de vidrio y Delrin®

\*: la presión de uso depende del tipo de empalme/racor elegido

Raccordi di completamento con attacco a forchetta da ordinare separatamente, nel capitolo:  
Fittings with fork connection should be ordered separately, in chapter:  
Racores con acople de horquilla se deben pedir por separado, en el capítulo:

**FITTINGS**





### Modelli con alimentazione a pile

- Alimentazione 2 pile AA (LR6)
- Spegnimento / accensione automatici

### Cell-powered models

- 2 cells AA (LR6)
- Automatic switching on/off

### Modelos con alimentación con pilas

- Alimentación 2 pilas AA (LR6)
- Apagado / encendido automáticos



COD. CODE CÓD.	Fork Coupling		Attacco Connection Toma	Ø Equiv.	P max		@ MAX.		⚡ *
	l/min.	US GPM			bar	PSI	bar	PSI	
<b>462 8405</b>	10-200	2.6-53	T5 F	1" 1/4	20	290	0,7	10	2 x AA (LR6)
<b>462 8506</b>	20-400	5-106	T6 F	1" 1/2	12	174	0,5	7	2 x AA (LR6)
<b>462 8707</b>	40-800	10-210	T7 F	2"	7	130	0,3	4	2 x AA (LR6)

Raccordi di completamento con attacco a forchetta da ordinare separatamente, nel capitolo:  
Fittings with fork connection should be ordered separately, in chapter:  
Racores con acople de horquilla se deben pedir por separado, en el capítulo:

**FITTINGS**

\*Pile non include  
Batteries not included  
Pilas no incluidas

### Modelli con alimentazione a batteria

- Disponibile con versione Stop Pompa per il comando automatico del caricamento in cisterna
- Impostazione della quantità di liquido da caricare in cisterna
- Tensione di alimentazione 12 Vdc
- Uscita ad impulsi 0-12 Vdc con frequenza proporzionale alla portata

### Battery-powered models

- Available with Pump Stop version for automatic tank filling command
- Selectable value for the fluid amount to be filled into the tank
- Power supply: 12 Vdc
- 0-12 Vdc pulse output with frequency proportional to rate

### Modelos con alimentación con batería

- Disponible con versión Stop Bomba para el mando automático de la carga en cisterna
- Configuración de la cantidad de líquido por cargar en cisterna
- Tensión de alimentación 12 Vcc
- Salida a impulsos 0-12 Vcc con frecuencia proporcional al caudal



COD. CODE CÓD.	Fork Coupling		Attacco Connection Toma	Ø Equiv.	P max		@ MAX.		⚡
	l/min.	US GPM			bar	PSI	bar	PSI	
<b>462 7405A</b>	10-200	2.6-53	T5 F	1" 1/4	20	290	0,7	10	12 Vdc
<b>462 7506A</b>	20-400	5-106	T6 F	1" 1/2	12	174	0,5	7	12 Vdc
<b>462 7707A</b>	40-800	10-210	T7 F	2"	7	130	0,3	4	12 Vdc

Raccordi di completamento con attacco a forchetta da ordinare separatamente, nel capitolo:  
Fittings with fork connection should be ordered separately, in chapter:  
Racores con acople de horquilla se deben pedir por separado, en el capítulo:

**FITTINGS**



# SISTEMI DI RIEMPIMENTO FILLING SYSTEMS SISTEMAS DE LLENAMIENTO

## Sistema di riempimento cisterna trasportabile

- Arresto automatico valvola al raggiungimento della quantità impostata
- Flussometro Orion 2 da 20 a 600 l/min
- Display retroilluminato
- Valvola elettrica con sfera in acciaio Inox
- Attacchi filettati da 2" maschio
- Supporto con maniglia per trasporto
- Cavo di alimentazione lunghezza 7,5 metri
- Tensione di alimentazione 12 Vdc

## Filling system for tank trailers

- Automatic valve stop once set quantity has been reached
- Orion 2 flow-meter from 20 to 600 l/min
- Backlit display
- Solenoid valve with stainless steel ball
- 2" threaded male connectors
- Support with transport handle
- 7.5 m power cable
- Power supply: 12 Vdc

## Sistema de carga cisterna transportable

- Parada automática válvula al alcanzar la cantidad programada
- Caudalimetro Orion 2 de 20 a 600 l/min.
- Display retroiluminado
- Válvula eléctrica con bola de acero Inox
- Tomas roscadas de 2" macho
- Soporte con manija para el transporte
- Cable de alimentación, longitud 7,5 metros
- Tensión de alimentación 12 Vcc



COD. CODE CÓD.		
	l/min.	US GPM
462 F2501	20÷400	5÷106
462 F2601	30÷600	8÷158

Alimentatore 12 Vdc multitemensione  
(110÷240 Vac) per sistema di  
caricamento

12 Vdc universal power supply (input  
110÷240 Vac) for filling system

Alimentador universal de 12 Vdc  
(110÷240 Vac) para sistema de carga  
cisterna



COD.  
CODE  
CÓD.  
467 006

### Sistema di riempimento cisterna

- Arresto automatico valvola al raggiungimento della quantità impostata
- Flussometro DIGIWOLF da 20 a 400 l/min
- Display grafico multilingua programmabile
- Coperchio di protezione del display con chiusura a scatto
- Valvola elettrica con sfera in acciaio Inox rivestita in TEFLON®
- Attacchi a forchetta T6
- Supporto con maniglia per trasporto
- Cavo di alimentazione lunghezza 7,5 metri
- Tensione di alimentazione 12 Vdc

### Caratteristiche

- Visualizzazione istantanea della portata (l/min)
- Visualizzazione del liquido erogato totale
- Unità di misura in litri, US Gallons, m<sup>3</sup>
- 2 totalizzatori con azzeramento indipendente
- Allarme programmabile soglia di flusso (min/max)
- Procedura assistita di calibrazione della costante
- Errore tipico 1% del fondoscala
- Pressione di utilizzo fino a 12 bar\*
- Parti a contatto con il fluido in Nylon® e polipropilene rinforzati con fibra di vetro, Delrin®, Acciaio Inox e TEFLON®.

\*: la pressione di utilizzo dipende dalla tipologia di attacco/raccordo scelto.

### Filling system for tank

- Automatic valve stop once set quantity has been reached
- DIGIWOLF flow-meter from 20 to 400 l/min
- Programmable multilingual graphic display
- Display snap-on cover
- Electrical valve with stainless steel TEFLON® coated sphere
- Fork coupling T6
- Support with transport handle
- 7.5 m power cable
- Power supply: 12 Vdc

### Features

- Instant rate display (l/min)
- Display of total quantity of liquid supplied
- Unit of measurement: liters, US Gallons, m<sup>3</sup>
- 2 separately resettable counters
- Programmable flow threshold alarm (min/max)
- Assisted constant setting procedure
- Typical error: 1% of the full scale
- Operating pressure: up to 12 bars\*
- Parts in contact with the fluid in Nylon and fiber glass reinforced polypropylene, Delrin®, Stainless Steel and TEFLON®.

\*: operating pressure depends on selected connector/union.

### Sistema de carga cisterna

- Parada automática válvula al alcanzar la cantidad programada
- Caudalímetro DIGIWOLF de 20 a 400 l/min.
- Pantalla gráfica multidioma programable
- Tapa de protección de la pantalla con cierre de resorte
- Válvula eléctrica con bola de Acero Inoxidable revestida en TEFLON®
- Toma de horquilla T6
- Soporte con manija para el transporte
- Cable de alimentación, longitud 7,5 metros
- Tensión de alimentación 12 Vcc

### Características

- Visualización instantánea del caudal (l/min)
- Visualización del total del líquido erogado.
- Unidad de medida en litros, US Gallons, m<sup>3</sup>
- 2 totalizadores con puesta a cero independiente
- Alarma programable umbral de flujo (mín/máx)
- Procedimiento asistido de calibración de la constante
- Error típico 1% del valor máximo
- Presión de uso hasta 12 bar\*
- Partes de contacto con el fluido de Nylon y polipropileno reforzadas con fibra de vidrio, Delrin®, Acero Inoxidable y TEFLON®.

\*: la presión de uso depende del tipo de empalme/racor elegido.

Raccordi di completamento con attacco a forchetta da ordinare separatamente, nel capitolo:  
Fittings with fork connection should be ordered separately, in chapter:  
Racores con acople de horquilla se deben pedir por separado, en el capítulo:

### FITTINGS



**T6**  
fork coupling

**T7**  
fork coupling

COD. CODE CÓD.			Attacco Connection Toma
	l/min.	US GPM	
<b>462 F4501</b>	20÷400	5÷106	T6
<b>462 F4701</b>	40÷800	10÷210	T7

