

GASPARDO

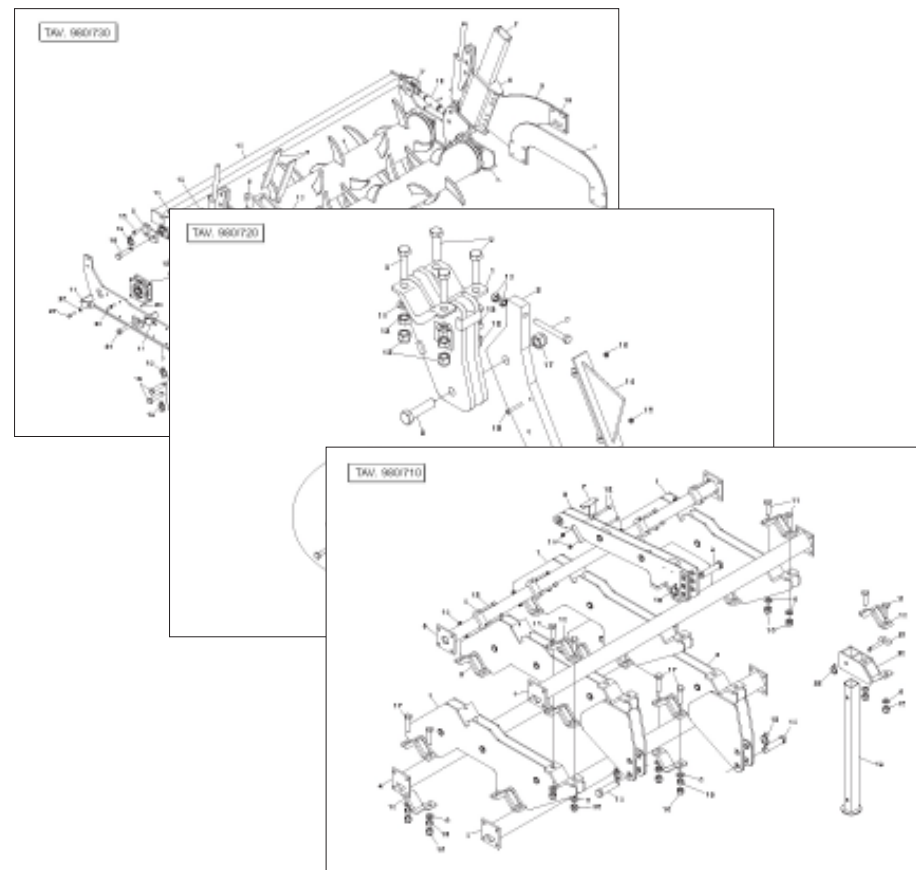

ARTIGLIO

Cod: 19530483 07.2005

GASPARDO

- IT** PARTI DI RICAMBIO
- EN** SPARE PARTS
- DE** ERSATZTEILE
- FR** PIÈCES DÉTACHÉES
- ES** PIEZAS DE REPUESTO

ITALIANO	ENGLISH	DEUTSCH	FRANÇAIS	ESPAÑOL
PARTI DI RICAMBIO	SPARE PARTS	ERSATZTEILE	PIECES DÉTACHÉES	RESPUESTOS
<p>Le ordinazioni delle parti di ricambio vanno fatte presso i nostri concessionari di zona e devono essere sempre corredate dalle seguenti indicazioni:</p> <ul style="list-style-type: none"> - Tipo, modello e numero di matricola dell'attrezzatura. Tali dati sono stampigliati nell'apposita targhetta di cui è dotata ogni attrezzatura. - Numero di codice della parte richiesta rilevabile dal catalogo ricambi. - Descrizione del particolare e quantità richiesta. - Numero della tavola. - Mezzo di trasporto. Nel caso questa voce non sia specificata, la Ditta Costruttrice, pur dedicando a questo servizio una particolare cura, non risponde di eventuali ritardi di spedizione dovuti a cause di forza maggiore. Le spese di trasporto si intendono sempre a carico del destinatario. La merce viaggia a rischio e pericolo del committente anche se venduta franco destino. <p>NOTA: Il termine (Dx) Destro o (Sx) Sinistro della macchina o di parti di essa, è inteso guardando la macchina dalla parte posteriore. Le eccezioni saranno indicate.</p>	<p><i>Orders must be transmitted through our area dealers and should always include the following indications:</i></p> <ul style="list-style-type: none"> - Type, model and serial number of the machine. <i>These data are punched on the data plate with which every implement is equipped.</i> - Code number of the required spare part. <i>This will be found in the spare parts catalogue.</i> - Description of the part and required quantity. - Table number. - Means of dispatch. <i>If this item is not indicated, the Manufacturer, while dedicating particular care to this service, shall not be held responsible for delays in delivery caused by cases of force majeure. Transport expenses shall always be at the consignee's charge. The goods travel at the purchaser's risk and peril even when sold ex destination.</i> <p>NOTE: <i>The symbols (Dx) right and (Sx) left, concerning the machine or single parts of it, are referred, as in the figure, to a rear view of them. Exceptions will be indicated.</i></p>	<p>Die Bestellungen müssen bei unseren Gebietshändlern aufgegeben werden. Bei der Bestellung sind stets die folgenden Angaben zu machen:</p> <ul style="list-style-type: none"> - Typ, Modell und Serien-Nummer des Geräts. Diese Daten stehen auf dem Typenschild, mit dem jedes Gerät versehen ist. - Artikel Nr. der erforderlichen Ersatzteile. Diese stehen im Ersatzteil-Katalog. - Beschreibung des Ersatzteils und die erforderliche Stückzahl. - Tafelnummer. - Versandmittel. Wenn dieser Punkt nicht spezifiziert wird, haftet die Herstellerfirma nicht für etwaigen Lieferverzug aufgrund höherer Gewalt, auch wenn er diesen Service besonders aufmerksam abwickelt. Die Frachtkosten gehen dagegen immer zu Lasten des Empfängers. Die Ware reist auf Gefahr und Risiko des Auftraggebers, auch wenn frei Haus Verkauft vereinbart worden ist. <p>N.B.: Die Merkzeichen (Dx) rechts und (Sx) links betreffen eine rückwärtige Aussicht der Maschine oder Teile von ihr (siehe Bild). Ausnahmen werden gezeigt.</p>	<p><i>Les ordres doivent être effectués auprès de nos concessionaires de zone en précisant les indications suivantes:</i></p> <ul style="list-style-type: none"> - Type, modèle et numéro de série de la machine. <i>Ces données sont gravées sur la plaque d'identification de chaque outil.</i> - Numéro de code de la pièce détachée indiqué sur le catalogue des pièces détachées. - Description de la pièce et quantité requise. - Numéro de plan. - Moyen d'expédition. <i>Si cette rubrique n'est pas indiquée, le Constructeur, bien que soucieux de ce service, ne répond pas des retards d'expédition pour des causes de force majeure. Les frais de transport sont toujours à la charge du destinataire. La marchandise voyage aux risques et périls de l'acheteur même si vendue franco de port.</i> <p>N.B.: <i>Les références (Dx) droit et (Sx) gauche de la machine ou des parties de la même, est entendue, comme de la figure, en regardant la machine de derriere dans le sens de marche.</i></p>	<p>Los pedidos han de efectuarse en nuestros concesionarios de zona y deben incluir siempre las siguientes indicaciones:</p> <ul style="list-style-type: none"> - Tipo, modelo y número de matrícula del equipo. Dichos datos están impresos en la relativa placa presente en el equipo. - Número de código de la parte requerida presente en el catálogo respuestos. - Descripción de la pieza y cantidad requerida. - Numero de ilustración. - Medio de transporte. En caso que este ítem no esté especificado, el Fabricante, aún prestando la debidas consideraciones para este aspecto, no responde por eventuales retardos de env'o debidos a causas de fuerza mayor. Los gastos de transporte se consideran siempre a cargo del destinatario. La mercadería viaja bajo riesgo y peligro del comprador, incluso cuando se vende franco destino. <p>N.B.: La refencia (Dx) derecha o (Sx) izquierda de la máquina o de sus componentes, se entiende, como en la figura, mirando la máquina por la parte trasera. Se indicarán las excepciones.</p>

INDICE DELLE TAVOLE - *TABLE INDEX* - VERZEICHNIS DER TAFELN - *INDEX DES PLANS* - INDICE ILUSTRACIONES

<i>N° Tavola</i>	<i>Descrizione</i>	<i>Pagina</i>
TAV. 980/712	Telaio ARTIGLIO 250-300	4
TAV. 980/790	Telaio ARTIGLIO 400-500	6
TAV. 980/723	Ancore	8
TAV. 980/733	Doppio rullo posteriore	10
TAV. 980/742	Impianto oleodinamico rulli posteriori	12
TAV. 980/751	Bandinelle laterali	14
TAV. 980/761	Dischi di contenimento	16
TAV. 980/780	Ruote di sostegno	18
TAV. 980/800	Attacco "IV" categoria	20

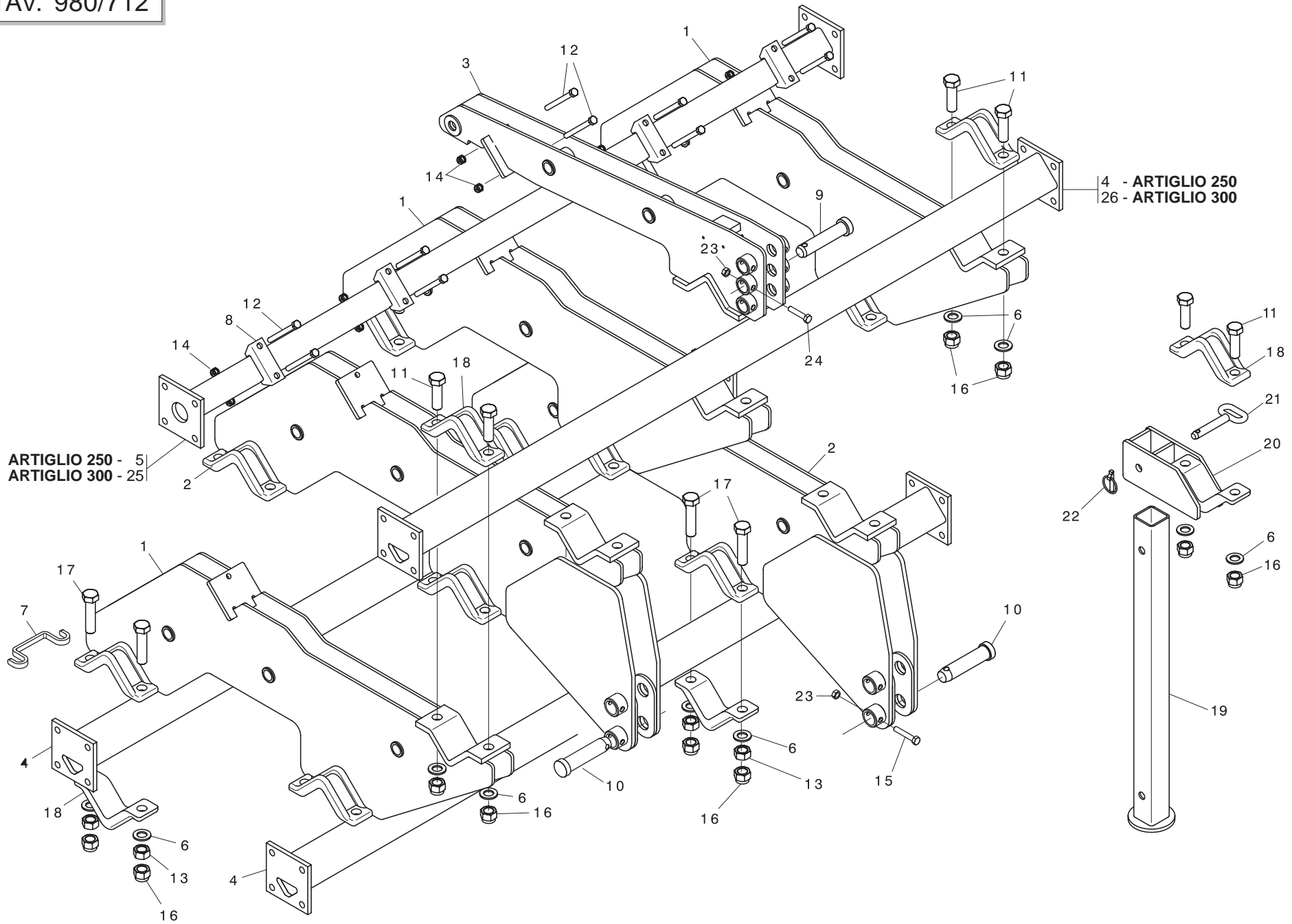

TELAIO ARTIGLIO 250-300

TAV. 980/712

Pos.	Cod.	Descrizione	Description	Description	Benennung	Descripcion
1	17810011	SUPPORTO TELAIO	FRAME SUPPORT	SUPPORT CH-SSIS	RAHMENHALTERUNG	SOPORTE BASTIDOR
2	17810073	SUPPORTO TELAIO	FRAME SUPPORT	SUPPORT CH-SSIS	RAHMENHALTERUNG	SOPORTE BASTIDOR
3	17810112	SUPPORTO TELAIO	FRAME SUPPORT	SUPPORT CH-SSIS	RAHMENHALTERUNG	SOPORTE BASTIDOR
4	17810140	TELAIO ANTERIORE 250	FRAME FRONT 250	BATI AVANT 250	VORDERRAHMEN 250	BASTIDOR DELANTERO 250
5	17810171	TELAIO POSTERIORE 250	MAIN FRAME 250	BATI ARRIERE 250	HINTERRAHMEN 250	BASTIDOR TRASERO 250
6	18701590	RONDELLA 25X35X2,5 ZN	WASHER 25 x 35 x2,5 ZN	RONDELLE 25 x 35 x2,5 ZN	UNTERLEGSCHIEBE 25 x 35 x2,5 Z	ARANDELA 25 x 35 x2,5 ZN
7	17812200	LAMA INTERPOSIZIONE SCONTRI ZN	BLADE	LAME	MESSER	CUCHILLA
8	16740160	SCONTRO A U SP.8 2F13 83	U-SHAPED STOP TEETH B343SP.8 2	BUT+E EN U EP.8 2F13 83	U-ANSCHLAG SP.8 2F13 83	DIENTE DE PARADA A U ESP.8 2F1
9	F20100101	SPINA GASPARDO 32X134 ZN	GASPARDO PIN 32X134 ZN	BROCHE GASPARDO 32X134 ZN	STIFT GASPARDO 32X134 ZN	CLAVIJA GASPARDO 32X134 ZN
10	F20100112	SPINA GASPARDO 36X134 ZN	GASPARDO PIN 36X134 ZN	BROCHE GASPARDO 36X134 ZN	STIFT GASPARDO 36X134 ZN	CLAVIJA GASPARDO 36X134 ZN
11	F01020343	VITE 24X 80 5737 10.9 ZN	BOLT 24X80 5737 10.9G GALVANI	VIS 24X80 5737 10.9G ZN	SCHRAUBE 24X80 5737 10.9G ZN	TORNILLO 24X80 5737 10.9G ZN
12	F01020174	VITE 12X120 5737 8.G ZN	BOLT 12X120 5737 8.G GALVANIZ.	VIS 12X120 5737 8.G ZN	SCHRAUBE 12X120 5737 8.G ZN	TORNILLO 12X120 5737 8.G ZN
13	F01200379	DADO 24 5588 6.8 ZN	NUT 24 5588 6.8 ZN	+CROU 24 5588 6.8 ZN	MUTTER 24 5588 6.8 ZN	TUERCA 24 5588 6.8 ZN
14	F01230058	DADO M12X1,25 D982 8 ZG	NUT M12X1,25 D982 8 ZG	ECROU M12X1,25 D982 8 Z	MUTTER M12X1,25 D982 8	TUERCA M12X1,25 D982 8
15	F01020164	VITE 12X70 5737 8.G ZN	BOLT 12X70 5737 8.G GALVANIZED	VIS 12X70 5737 8.G ZN	SCHRAUBE 12X70 5737 8.G ZN	TORNILLO 12X70 5737 8.G ZN
16	F01230143	DADO AUTOB.NOR.24X2 ZN	NORMAL SELF-LOCK.NUT 24X2 GAL	ECROU AUTOB. NOR. 24X2 ZN	MUTTER AUTOB.NOR.24X2 ZN	TUERCA AUTOB. NOR.24X2 ZN
17	F01020344	VITE 24X100 5737 10.9 ZN	SCREW 24X100 5737 10.9 ZN	VIS 24X100 5737 10.9 ZN	SCHRAUBE 24X100 5737 10.9 ZN	TORNILLO 24X100 5737 10.9 ZN
18	17811170	SCONTRO PER TUBO 100	STRIKER PLATE 100	BUTEE 100	ANSCHLAG 100	ELEMENTO DE EMPALME 100
19	17810380	PUNTELLO	PROP	ETRESILLON	ST_TZE	PUNTAL
20	17810411	SUPPORTO PUNTELLO	PROP SUPPORT	SUPPORT ETRESILLON	STsTZENHALTERUNG	SOPORTE PUNTAL
21	17810440	PERNO ZN	PIN ZN	PIVOT ZN	BOLZEN ZN	PERNO ZN
22	F02200507	SPINA A SCATTO D 9 B/83	SNAP PIN D 9 B/83	FICHE A DETENTE D. 9 B/83	EINRASTSTIFT D 9 B/83	CLAVIJA DE MUELLE D 9 B/83
23	F01220244	DADO TRISTOP M12	NUT- TRISTOP M12	ECROU TRISTOP M12	MUTTER TRISTOP M12	TUERCA TRISTOP M12
24	F01020160	VITE 12X60 5737 8.G ZN	BOLT 12X60 5737 8.G GALVANIZED	VIS 12X60 5737 8.G ZN	SCHRAUBE 12X60 5737 8.G ZN	TORNILLO 12X60 5737 8.G ZN
25	17810460	TELAIO ANTERIORE 300	FRAME FRONT 300	BATI AVANT 300	VORDERRAHMEN 300	BASTIDOR DELANTERO 300
26	17810481	TELAIO POSTERIORE 300	MAIN FRAME 300	BATI ARRIERE 300	HINTERRAHMEN 300	BASTIDOR TRASERO 300

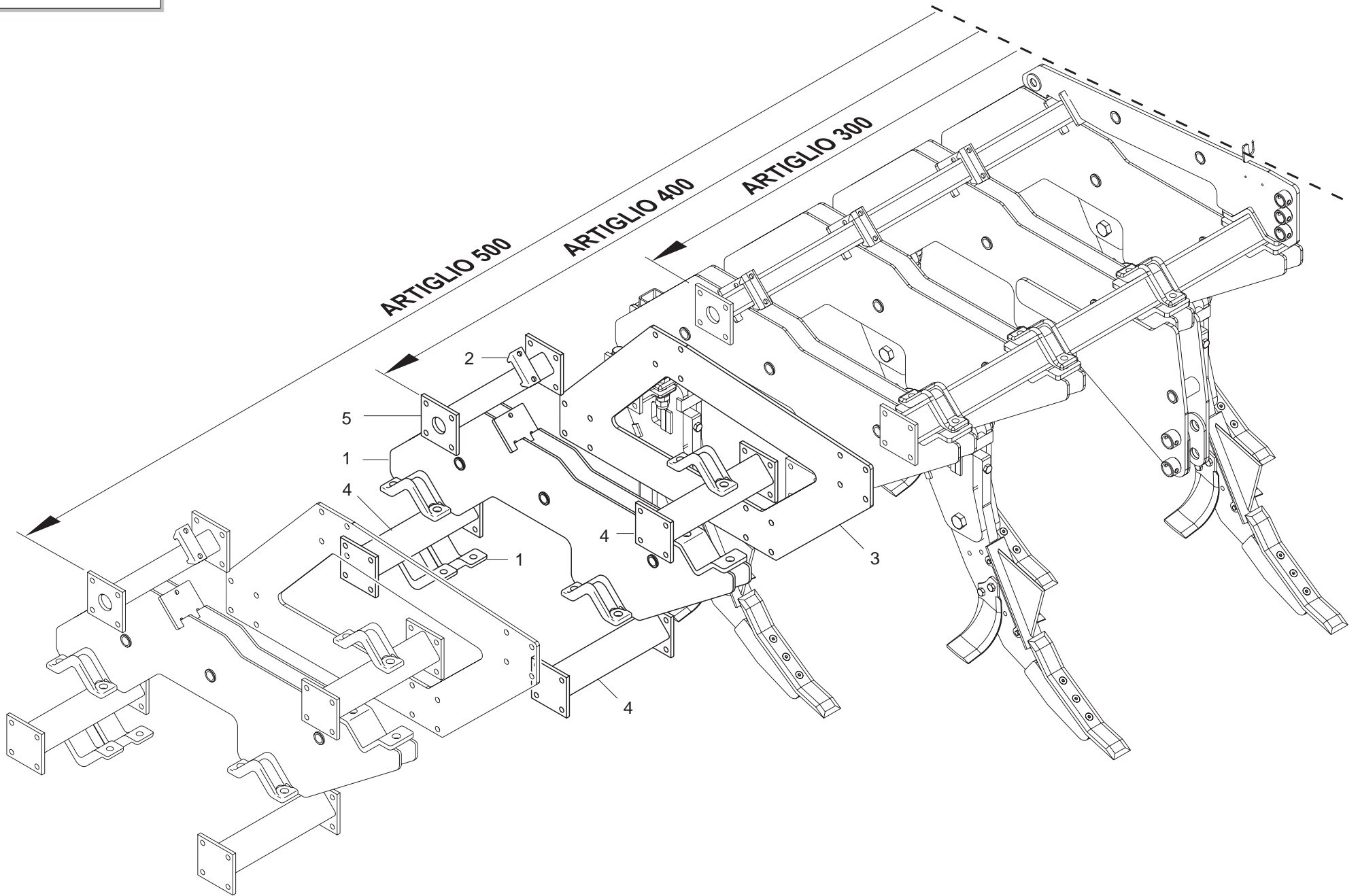

TELAIO ARTIGLIO 400-500

TAV. 980/790

Pos.	Cod.	Descrizione	Description	Description	Benennung	Descripcion
1	17811170	SCONTRO PER TUBO 100	STRIKER PLATE 100	BUTEE 100	ANSCHLAG 100	ELEMENTO DE EMPALME 100
2	16740160	SCONTRO A U SP.8 2F13 83	U-SHAPED STOP TEETH B343SP.8 2	BUT+E EN U EP.8 2F13 83	U-ANSCHLAG SP.8 2F13 83	DIENTE DE PARADA A U ESP.8 2F1
3	17812030	LAMA DI RINFORZO	BLADE REINFORCEMENT	LAME RENFORCEMENT	MESSER VERSTZRKUNG	CUCHILLAS REFUERZO
4	17812050	TELAIO L.444	FRAME L.444	BATI L. 444	RAHMEN L.444	BASTIDOR L.444
5	17812070	TELAIO L.444	FRAME L.444	BATI L. 444	RAHMEN L.444	BASTIDOR L.444

TAV. 980/723

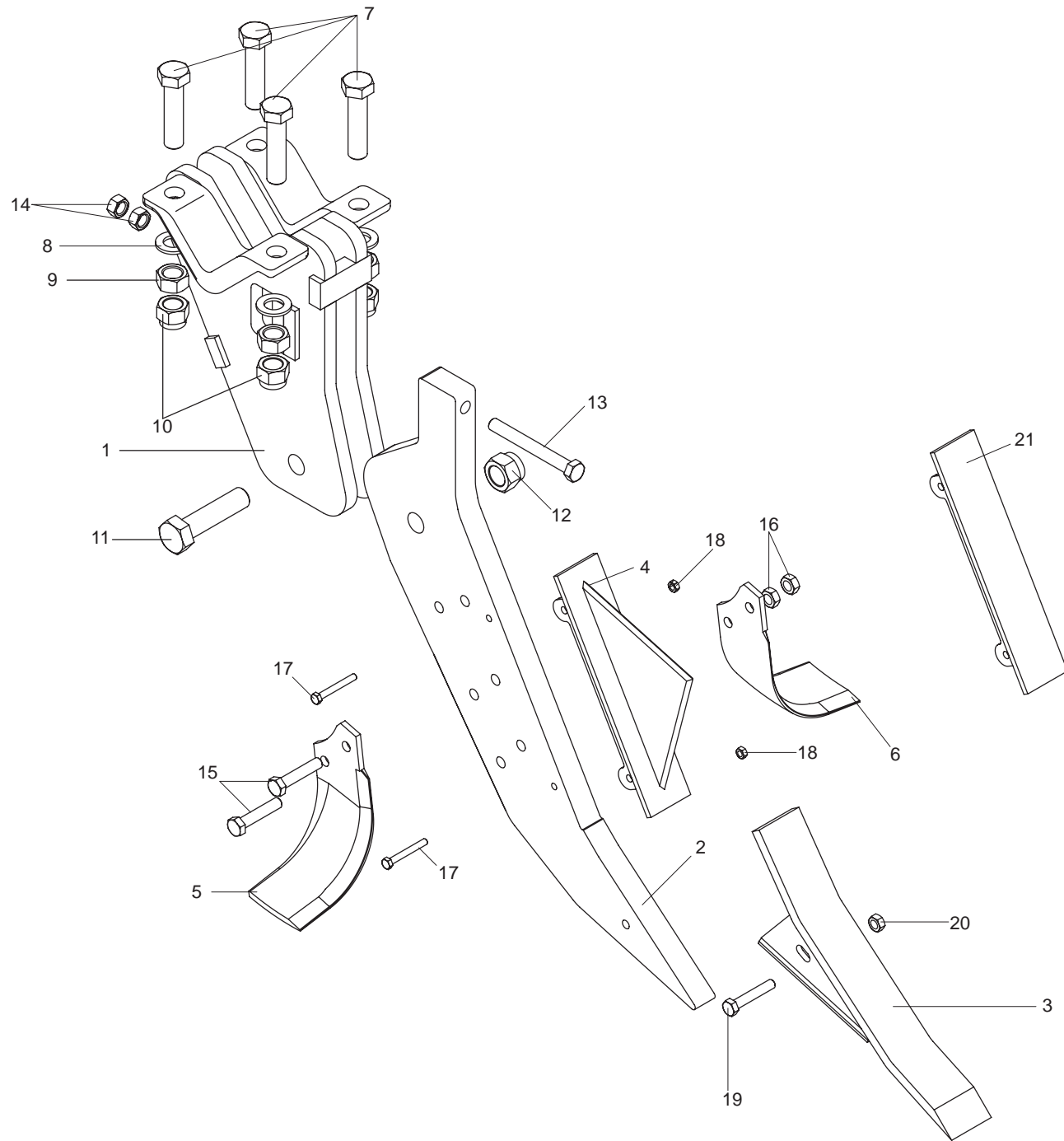

Pos.	Cod.	Descrizione	Description	Description	Benennung	Descripcion
1	17820012	SUPPORTO PUNTALE	SUPPORT FOR EARTH-OPENING BLAD	SUPPORT EMBOUT	MESSERHALTER	SOPORTE PUNTAL
2	17820440	PUNTALE	TIP	EMBOUT	STÜTZE	PUNTAL
3	17820480	DENTE	TOOTH DENT	EMBOUT GRIFFE	ZAHN KLAUESTÜTZE	DIENTE PUNTAL GARRA
4	17820061	LAMA ROMPIZOLLE	CLOD-BREAKING BLADE	LAME BRISE-MOTTES	MESSER SCHOLLENBRECHER	CUCHILLA DESTERRONADOR
5	M01110426	ZAPPA ELICA DESTRA	RIGHT HELICOIDAL BLADE	LAME HELICE B-C-SC DRT	RECHTES BOGENMESSER	AZADA HELICE DERECHA
6	M01110427	ZAPPA ELICA SINISTRA	LEFT HELICOIDAL BLADE	LAME HELICE B-C-SC GCH	LINKES BOGENMESSER	AZADA HELICE IZQUIERDA
7	F01020344	VITE 24X100 5737 10.9 ZN	SCREW 24X100 5737 10.9 ZN	VIS 24X100 5737 10.9 ZN	SCHRAUBE 24X100 5737 10.9 ZN	TORNILLO 24X100 5737 10.9 ZN
8	18701590	RONDELLA 25X35X2,5 ZN	WASHER 25 x 35 x2,5 ZN	RONDELLE 25 x 35 x2,5 ZN	UNTERLEGSSCHEIBE 25 x 35 x2,5 Z	ARANDELA 25 x 35 x2,5 ZN
9	F01200379	DADO 24 5588 6.8 ZN	NUT 24 5588 6.8 ZN	+CROU 24 5588 6.8 ZN	MUTTER 24 5588 6.8 ZN	TUERCA 24 5588 6.8 ZN
10	F01230144	DADO AUTOB.NORM.24 ZN	SELF-LOCKING NUT NORM.24 ZN	+CROU AUTOB.NORM.24 ZN	SELBSTSPERR. MUTTER NORM.24 ZN	TUERCA AUTOB. NORM.24 ZN
11	F01061000	VITE 27X110 5712 10.9 ZN	SCREW 27X110 5712 10.9 ZN	VIS 27X110 5712 10.9 ZN	SCHRAUBE 27X110 5712 10.9 ZN	TORNILLO 27X110 5712 10.9 ZN
12	F01230150	DADO AUTOB.NORM.27 ZN	SELF-LOCKING NUT NORM.27 ZN	+CROU AUTOB.NORM.27 ZN	SELBSTSPERR. MUTTER NORM.27 ZN	TUERCA AUTOB. NORM.27 ZN
13	F01020269	VITE 16X140 6737 8.G ZN	BOLT 16X140 6737 8.G GALVANIZ	VIS 16X140 6737 8.G ZN	SCHRAUBE 16X140 6737 8.G ZN	TORNILLO 16X140 6737 8.G ZN
14	F01200321	DADO M16X 2 U5588 6.8 ZG	NUT M16X 2 U5588 6.8 ZG	ECROU M16X 2 U5588 6.8 ZG	MUTTER M16X 2 U5588 6.8 ZG	TUERCA M16X 2 U5588 6.8 ZG
15	F01020207	VITE 14X70 5737 8.G ZN	SCREW 14X70 5737 8.G GALVAN.	VIS 14X70 5737 8.G ZN	SCHRAUBE 14X70 5737 8.G ZN	TORNILLO 14X70 5737 8.G ZN
16	F01230073	DADO AUTOB.NOR.14 ZN	NORMAL SELF-LOCKING NUT 14 GAL	ECROU AUTOB. NOR. 14 ZN	MUTTER AUTOB.NOR.14 ZN	TUERCA AUTOB. NOR.14 ZN
17	F01020082	VITE 8 X65 5737 8.G ZN	BOLT 8 X65 5737 8.G GALVANIZED	VIS 8 X65 5737 8.G ZN	SCHRAUBE 8 X65 5737 8.G ZN	TORNILLO 8 X65 5737 8.G ZN
18	F01220222	DADO TRISTOP M 8	NUT- TRISTOP M 8	ECROU TRISTOP M 8	MUTTER TRISTOP M 8	TUERCA TRISTOP M 8
19	F01020164	VITE 12X70 5737 8.G ZN	BOLT 12X70 5737 8.G GALVANIZED	VIS 12X70 5737 8.G ZN	SCHRAUBE 12X70 5737 8.G ZN	TORNILLO 12X70 5737 8.G ZN
20	F01230059	DADO AUTOB.NOR.12 ZN	NORMAL SELF-LOCKING NUT 12 GAL	ECROU AUTOB. NOR. 12 ZN	SELBSTSP. MUTTER NOR.12 ZN	TUERCA AUTOB. NOR.12 ZN
21	17820260	LAMA PROTEZIONE	GUARD	PROTECTION	SCHUTZ	PROTECCIÓN

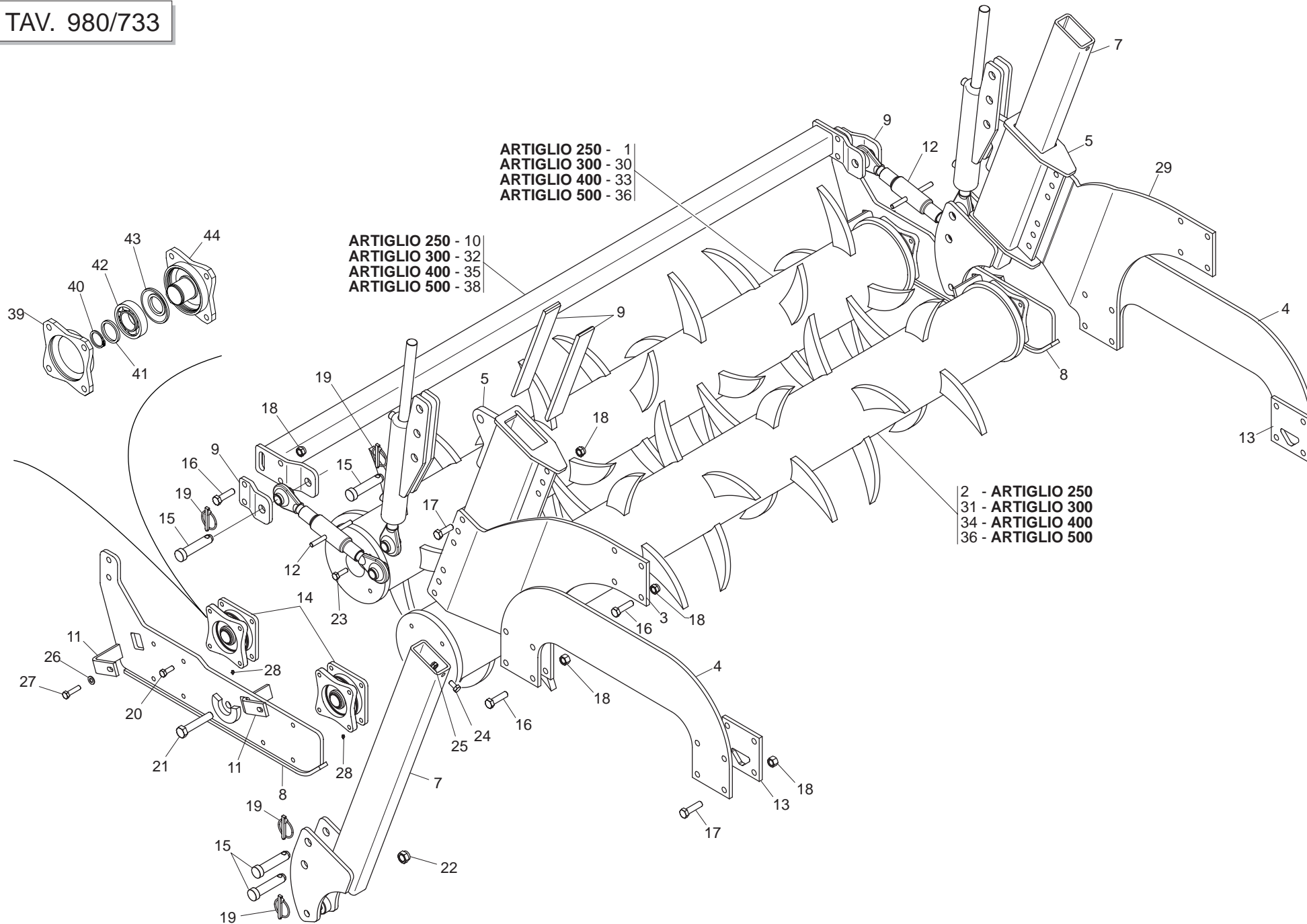

DOPPIO RULLO POSTERIORE

TAV. 980/733

Pos.	Cod.	Descrizione	Description	Description	Benennung	Description
1	17811181	RULLO 32 DENTI 250	ROLLER- 32 TEETH 250	ROULEAU A 32 DENTS 250	32 ZAHN ROLLE 250	RODILLO DE 32 DIENTES 250
2	17811191	RULLO 28 DENTI 250	ROLLER- 28 TEETH 250	ROULEAU A 28 DENTS 250	28 ZAHN ROLLE 250	RODILLO DE 28 DIENTES 250
3	17812220	LAMA SUPPORTO REGOLAZIONE	SUPPORT BLADE ADJUSTMENT	SUPPORT LAME REGLAGE	HALTERUNG MESSER	CUCHILLA SOPORTE
4	17811270	LAMA DI RINFORZO	BLADE REINFORCEMENT	LAME RENFORCEMENT	MESSER VERSTZRKUNG	CUCHILLAS REFUERZO
5	17811320	SUPPORTO SCORRIMENTO RULLI	ROLLER SUPPORT SLIDING	SUPPORT DE GLISSEMENT ROULEAU	HALBGLEITHALTERUNG	SOPORTE DE DESPLAZAMIENTO
6	17811331	LAMA DI SCORRIMENTO	BLADE SLIDING	LAME DE GLISSEMENT	GLEITMESSER	CUCHILLAS DE DESPLAZAMIENTO
7	17811370	LEVA SCORRIMENTO RULLI	LEVER SLIDING	LEVIER DE GLISSEMENT	GLEITHEBEL	PALANCA DE DESPLAZAMIENTO
8	17811401	SUPPORTO RULLO	ROLLER SUPPORT	SUPPORT ROULEAUX	RIEMENSPANNERROLLEN	SOPORTE RODILLOS
9	17811410	LAMA DI ATTACCO	BLADE	LAME	MESSER	CUCHILLA
10	17811431	PROTEZIONE	GUARD	PROTECTION	SCHUTZ	PROTECIÉN
11	17811450	RASCHIATERRA	SOIL SCRAPER	RACLEUR	ERDSCHABER	RASCADOR DE TIERRA
12	17811490	TIRANTE TERZO PUNTO	3° POINT TIE ROD	TRINGLE 3° POINT	SPANNSTANGE 3° PUNKT	TIRANTE 3° PUNTO
13	17810160	SCONTRO 145X145-12 4F17 105	STRIKER PLATE 145X145	BUTEE 145X145	ANSCHLAG 145X145	ELEMENTO DE EMPALME 145X145
14	17014180	SUPPORTO CUSCINETTO	BEARING SUPPORT	SUPPORT ROULEMENT	LAGERHALTERUNG	SOPORTE COJINETE
15	F20100063	SPINA GASPARDO 25X97	GASPARDO PIN 25X97	BROCHE GASPARDO 25X97	STIFT GASPARDO 25X97	CLAVIJA GASPARDO 25X97
16	F01020256	VITE 16X60 5737 8.G ZN	BOLT 16X60 5737 8.G GALVANIZED	VIS 16X60 5737 8.G ZN	SCHRAUBE 16X60 5737 8.G ZN	TORNILLO 16X60 5737 8.G ZN
17	F01020252	VITE 16X50 5737 8.G ZN	SCREW 16X50 5737 8.G GALVANIZ	VIS 16X50 5737 8.G ZN	SCHRAUBE 16X50 5737 8.G ZN	TORNILLO 16X50 5737 8.G ZN
18	F01230085	DADO AUTOB.NOR.16 ZN	NORMAL SELF-LOCKING NUT 16 GAL	ECROU AUTOB. NOR. 16 ZN	MUTTER AUTOB.NOR.16 ZN	TUERCA AUTOB. NOR.16 ZN
19	F02200507	SPINA A SCATTO D 9 B/83	SNAP PIN D 9 B/83	FICHE A DETENTE D. 9 B/83	EINRASTSTIFT D 9 B/83	CLAVIJA DE MUELLE D 9 B/83
20	F01010288	VITE 12X1,25X35 5740 8.8 ZN	SCREW 12X1.25X35 5740 8.8 ZN	VIS 12X1,25X35 5740 8.8 ZN	SCHRAUBE 12X1,25X35 5740 8.8 Z	TORNILLO 12X1,25X35 5740 8.8 Z
21	F01020313	VITE 20X110 5737 8.G ZN	BOLT 20X110 5737 8.G GALVANIZ.	VIS 20X110 5737 8.G ZN	SCHRAUBE 20X110 5737 8.G ZN	TORNILLO 20X110 5737 8.G ZN
22	F01230131	DADO AUTOB.NOR.20 ZN	NORMAL SELF-LOCKING NUT 20 GAL	ECROU AUTOB. NOR. 20 ZN	MUTTER AUTOB.NOR.20 ZN	TUERCA AUTOB. NOR.20 ZN
23	F01020528	VITE 12X40 5739 10.9 ZN	SCREW 12X40 5739 10.9 ZN	VIS 12X40 5739 10.9 ZN	SCHRAUBE 12X40 5739 10.9 ZN	TORNILLO 12X40 5739 10.9 ZN
24	F01020508	VITE 12X25 5739 8.G ZN	SCREW 12X25 5739 8.G GALVANIZ.	VIS 12X25 5739 8.G ZN	SCHRAUBE 12X25 5739 8.G ZN	TORNILLO 12X25 5739 8.G ZN
25	F01230058	DADO M12X1,25 D982 8 ZG	NUT M12X1,25 D982 8 ZG	ECROU M12X1,25 D982 8 Z	MUTTER M12X1,25 D982 8	TUERCA M12X1,25 D982 8
26	F01410076	RONDELLA D12 UNI 6592 ZN	WASHER D12 UNI 6592 ZN	RONDELLE D12 UNI 6592 ZN	UNTERLEGSSCHEIBE D12 UNI 6592 Z	ARANDELA D12 UNI 6592 ZN
27	F01010292	VITE 12X1,25 X45 5740 8.8 ZN	SCREW 12X1.25X45 5740 8.8 ZN	VIS 12X1,25X45 5740 8.8 ZN	SCHRAUBE 12X1,25X45 5740 8.8 Z	TORNILLO 12X1,25X45 5740 8.8 Z
28	F01100011	INGRASS.A SFERE M6X1/A	SPHERE NIPPLE M6X1/A	GRAISSEUR A BILLES M6X1/A	KUGELFETTBSCHSE M6X1/A	ENGRAS. DE ESFERAS M6X1/A
29	17812230	LAMA SUPPORTO REGOLAZIONE	SUPPORT BLADE ADJUSTMENT	SUPPORT LAME REGLAGE	HALTERUNG MESSER	CUCHILLA SOPORTE
30	17811201	RULLO 40 DENTI 300	ROLLER- 40 TEETH 300	ROULEAU A 40 DENTS 300	40 ZAHN ROLLE 300	RODILLO DE 40 DIENTES 300
31	17811211	RULLO 36 DENTI 300	ROLLER- 36 TEETH 300	ROULEAU A 36 DENTS 300	36 ZAHN ROLLE 300	RODILLO DE 36 DIENTES 300
32	17811611	PROTEZIONE	GUARD	PROTECTION	SCHUTZ	PROTECIÉN
33	17812111	RULLO 52 DENTI 400	ROLLER- 52 TEETH 400	ROULEAU A 52 DENTS 400	52 ZAHN ROLLE 400	RODILLO DE 52 DIENTES 400
34	17812121	RULLO 48 DENTI 400	ROLLER- 48 TEETH 400	ROULEAU A 48 DENTS 400	48 ZAHN ROLLE 400	RODILLO DE 48 DIENTES 400
35	17812091	PROTEZIONE 4 M	GUARD 4 M	PROTECTION 4 M	SCHUTZ 4 M	PROTECIÉN 4 M
36	17813280	RULLO 64 DENTI 500	ROLLER- 64 TEETH 500	ROULEAU A 64 DENTS 500	64 ZAHN ROLLE 500	RODILLO DE 64 DIENTES 500
37	17813290	RULLO 60 DENTI 500	ROLLER- 60 TEETH 500	ROULEAU A 60 DENTS 500	60 ZAHN ROLLE 500	RODILLO DE 60 DIENTES 500
38	17813270	PROTEZIONE 4 M	GUARD 4 M	PROTECTION 4 M	SCHUTZ 4 M	PROTECIÉN 4 M
39	M38100992	SUPPORTO RULLO OSCILL.DI TESTA	BEARING SUPPORT FLANGE	FLASQUE SUPPORT ROULEMENT	LAGERFLANSCH	BRIDA SOPORTE COJINETE
40	F02050168	ANEL.EL.PER EST.DE40 UNI7435	SEEGER RING D.40	BAGUE SEEGER D.40	SEEGERRING D.40	ANILLO SEEGER D.40
41	M48000307	ANELLO RINF.40X50X1,5 C70 TEMP	SEEGER STIFFENER RING	ANNEAU DE RENFORCEMENT SEEGER	SEEGER RING	ANILLO REFUERZO SEEGER
42	F04010184	CUSC.DE SFERICO 76208 A2KS FAG	BEARING 6208 SEE	ROULEMENT 6208 SEE	LAGER 6208 SEE	COJINETE 6208 SEE
43	M38100990	GUARNIZIONE ELASTICA	GASKET	JOINT	DICHTUNG	JUNTA
44	M38100991	MOZZO RULLO OSCILLANTE FINITO	SWINGING ROLLER HUB	MOYEU ROTOR OSCILLANTE	SCHWIMMENDE NABE	CUBO ROTOR OSCILANTE

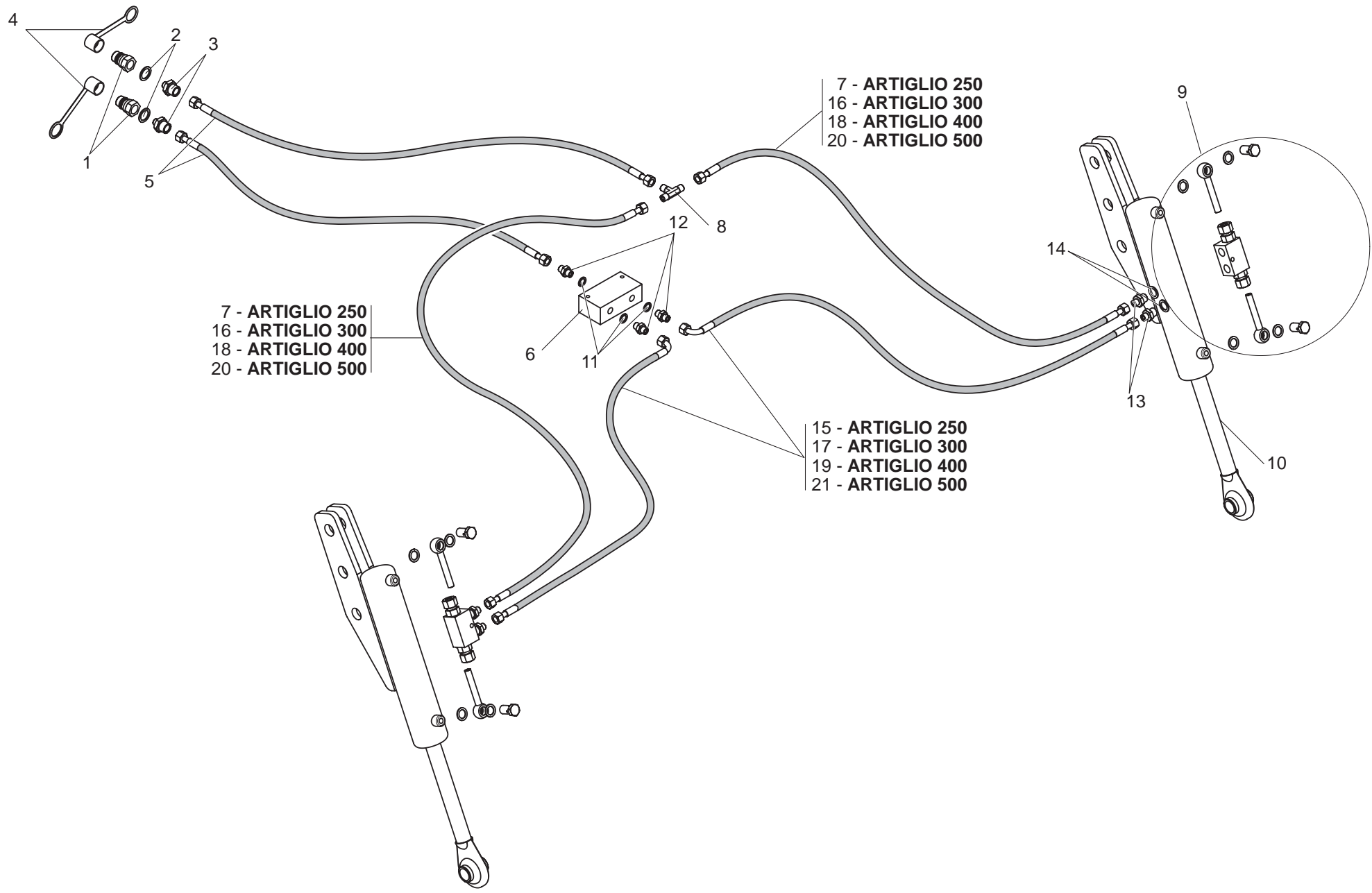

IMPIANTO OLEODINAMICO RULLI POSTERIORI

TAV. 980/742

Pos.	Cod.	Descrizione	Description	Description	Benennung	Description
1	F03150935	INNESTO RAPIDO MASCH.CONO 1/2	QUICK CONNECT MALE CONE 1/2 CO	CONNEXION RAPIDE MALE CONE 1/2	SCHNELLKUPPLUNG GEWINDE KONISC	ACOPLAMIENTO Rápido MACHO CONO
2	F03151237	RONDELLA RAME 1/2	1/2 COPPER WASHER	RONDELLE CUIVRE ®	UNTERLEGSCHEIBE KUPFER 1/2	ARANDELA COBRE 1/2
3	F03150211	NIPPLO MASCH.CIL.1/2-1/4 ZN	NIPPLE- GALVAN. CYLINDR.MALE-	NIPPLE MALE CYL. 1/2-1/4 ZN	NIPPELZYL.1/2-1/4 ZN	NIPLE MACHO CIL.1/2-1/4 ZN
4	F05150325	CAPPUCCIO INNESTO 1/2	CONNECTION CAP NUT 1/2	CAPUCHON ACCOUPLEMENT 1/2	HAUBE KUPPLUNG 1/2	CAPUCHON ACOPLAMIENTO 1/2
5	23440517	TUBO 1/4R2 C-F 1/4 L2000 HL/ID	PIPE 1/4R1 C-F 1/4 L2000 HL/ID	TUBE 1/4R1 C-F 1/4 L2000 HL/ID	ROHR 1/4R1 C-F 1/4 L2000 HL/ID	TUBO 1/4R1 C-F 1/4 L2000 HL/ID
6	F03151259					
7	17915100	TUBO 1/4 F-F L.2800	TUBE 1/4 F-F L.2800	TUBE 1/4 F-F L.2800	ROHR 1/4 F-F L.2800	TUBO 1/4 F-F L.2800
8	F03151219	RACCORDO -T- MASCHIO 1/4 ZINC.	MALE T-UNION 1/4 ZINC.	RACCORD -T- MALE 1/4 ZING.	ANSCHLUSSTsCK -T- GEWINDE 1/4	UNIN -T- MACHO 1/4 CINC. R
9	F03151158					
10	17811481	CILINDRO 30X70 - 280	CYLINDER 30X70 - 280	CYLINDRE 30X70 - 280	ZYLINDER 30X70 - 280	CILINDRO 30X70 - 280
11	F03151238	RONDELLA RAME 1/4	1/4 COPPER WASHER	RONDELLE CUIVRE ^a	UNTERLEGSCHEIBE KUPFER 1/4	ARANDELA COBRE 1/4
12	F03150266	NIPPLO MASCH.CIL.1/4 ZN	NIPPLE GALV.CYLINDR.MALE 1/4	NIPPLE MALE CYL. 1/4 ZN	NIPPELZYL.1/4 ZN	NIPLE MACHO CIL.1/4 ZN
13	F03150310	NIPPLO MASCH.CIL.3/8-1/4 ZN	NIPPLE GALV.CYL.MALE 3/8-1/4	NIPPLE MALE CYL.3/8-1/4 ZN	NIPPELZYL.3/8-1/4 ZN	NIPLE MACHO CIL.3/8-1/4 ZN
14	F03151240	RONDELLA RAME 3/8	3/8 COPPER WASHER	RONDELLE CUIVRE 3/8	UNTERLEGSCHEIBE KUPFER 3/8	ARANDELA COBRE 3/8
15	22505141	TUBO 1/4R2 C-F L.2750 LM	PIPE 1/4R1 C-F L.2750 LM	TUBE 1/4R1 C-F L. 2750 LM	ROHR 1/4R1 C-F L.2750 LM	TUBO 1/4R1 C-F L.2750 LM
16	G17814480	TUBO 1/4R2 F-F L.3000 LM	PIPE 1/4R1 F-F L.3000 LM	TUBE 1/4R1 F-F L. 3000 LM	ROHR 1/4R1 F-F L.3000 LM	TUBO 1/4R1 F-F L.3000 LM
17	22505142	TUBO 1/4R2 C-F L.3000 LM	PIPE 1/4R1 C-F L.3000 LM	TUBE 1/4R1 C-F L. 3000 LM	ROHR 1/4R1 C-F L.3000 LM	TUBO 1/4R1 C-F L.3000 LM
18	G17814490	TUBO 1/4 R2 F-F 1/4 L.3150	PIPE 1/4-R2 F-F 1/4 M.3-15	TUBE 1/4-R2 F-F 1/4 M.3-15	ROHR 1/4-R2 F-F 1/4 M.3-15	TUBO 1/4-R2 F-F 1/4 M.3-15
19	15210950	TUBO 1/4 R2 C-F 1/4 L.3150	PIPE 1/4-R2 C-F 1/4 M.3-15	TUBE 1/4-R2 C-F 1/4 M.3-15	ROHR 1/4-R2 C-F 1/4 M.3-15	TUBO 1/4-R2 C-F 1/4 M.3-15
20	22240565	TUBO 1/4R2 F-F 1/4 L.3600 LM	TUBE 1/4R2 F-F 1/4 L.3600 LM	TUBE 1/4R2 F-F 1/4 L.3600 LM	ROHR1/4R2 F-F 1/4 L.3600 LM	TUBO 1/4R2 F-F 1/4 L.3600 LM
21	22505143	TUBO 1/4R2 C-F 1/4 L.3500 LM	PIPE 1/4R1 C-F 1/4 L.3500 LM	TUBE 1/4R1 C-F 1/4 L. 3500 LM	ROHR 1/4R1 C-F 1/4 L.3500 LM	TUBO 1/4R1 C-F 1/4 L.3500 LM

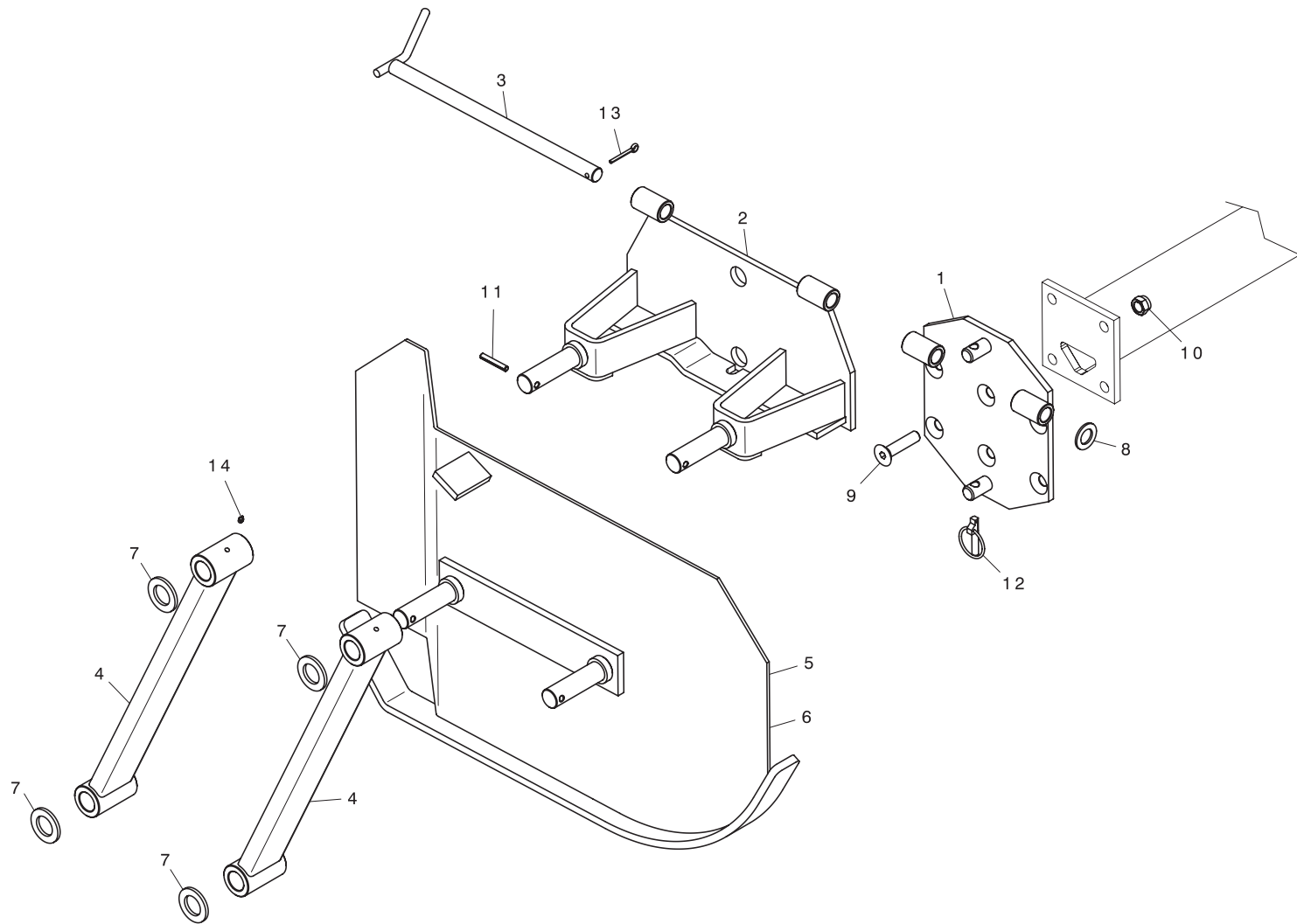

BANDINELLE LATERALI

TAV. 980/751

Pos.	Cod.	Descrizione	Description	Description	Benennung	Descripcion
1	17811650	PIASTRA DI ATTACCO	FIXING PLATE	PLAQUE DE RACCORD	KUPPLUNGSPLATTE	PLACA DE CONEXIN
2	17811710	RIBALTAMENTO BANDELLE	SUPPORT	SUPPORT	HALTERUNG	SOPORTE
3	17811730	PERNO ZN	PIN ZN	PIVOT ZN	BOLZEN ZN	PERNO ZN
4	17811760	LEVA	LEVER	LEVIER	HEBEL	PALANCA
5	17811821	BANDELLA SX	PROTECTION SX	PROTECTION SX	SCHUTZ SX	PROTECIÉN SX
6	17811831	BANDELLA DX	PROTECTION DX	PROTECTION DX	SCHUTZ DX	PROTECIÉN DX
7	20970067	RONDELLA 54X5X32	WASHER 54X5X32	RONDELLE 54X5X32	UNTERLEGSCHIEBE 54X5X32	ARANDELA 54X5X32
8	F02200229	COPIGLIA 5 X45 1336 ZN	SPLIT PIN 5 X45 1336 GALVAN.	GOUPILLE 5 X45 1336 ZN	SPLINT 5 X45 1336 ZN	PASADOR 5 X45 1336 ZN
9	F01030152	VITE 16X70 5933 8.G ZN	BOLT 16X70 5933 8.G GALVANIZED	VIS 16X70 5933 8.G ZN	SCHRAUBE 16X70 5933 8.G ZN	TORNILLO 16X70 5933 8.G ZN
10	F01230085	DADO AUTOB.NOR.16 ZN	NORMAL SELF-LOCKING NUT 16 GAL	ECROU AUTOB. NOR. 16 ZN	MUTTER AUTOB.NOR.16 ZN	TUERCA AUTOB. NOR.16 ZN
11	F02100144	SPINA EL.8X50 DIN 1481	PIN EL. .8 X50 DIN 1481	FICHE EL.8 X50 DIN 1481	SPANNSTIFT 8 X50 DIN 1481	CLAVIJA EL.8 X50 DIN 1481
12	F02200507	SPINA A SCATTO D 9 B/83	SNAP PIN D 9 B/83	FICHE A DETENTE D. 9 B/83	EINRASTSTIFT D 9 B/83	CLAVIJA DE MUELLE D 9 B/83
13	F01410135	RONDELLA D22 UNI 6592 ZN	WASHER D22 UNI 6592 ZN	RONDELLE D22 UNI 6592 ZN	UNTERLEGSCHIEBE D22 UNI 6592 Z	ARANDELA D22 UNI 6592 ZN
14	F01100048	INGRASS.A SFERE M8 X 1,25 A	SPHRE NIPPLE M8 X 1-25 A	GRAISSEUR A BILLES M8 X 1-25 A	KUGELFETTBSCHSE M8 X 1-25 A	ENGRAS. DE ESFERAS M8 X 1-25 A

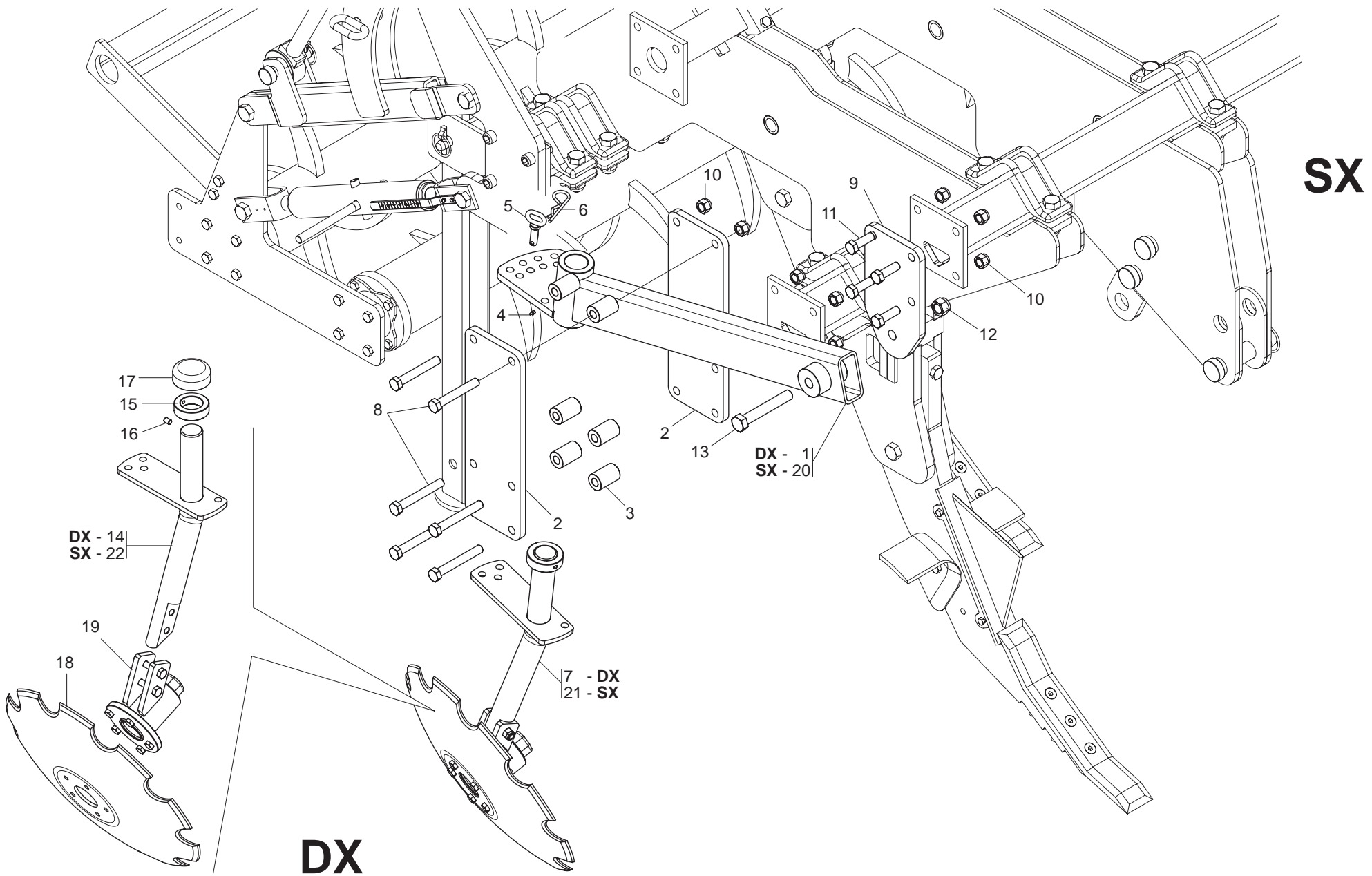

SX

DX

DISCHI DI CONTENIMENTO

TAV. 980/761

Pos.	Cod.	Descrizione	Description	Description	Benennung	Descripcion
1	17810900	SUPPORTO DISCO DX	DISC SUPPORT DX	SUPPORT DISQUE DX	SCHEIBENHALTERUNG DX	SOPORTE DISCO DX
2	17810820	LAMA REGOLAZIONE FINECORSIA	TRAVEL STOP BRACKET	BRIDE FIN DE COURSE	BsGEL ENDANSCHLAG	ESTR. FINAL DE CARRERA
3	17810880	BOCCOLA 16,5 X35 X52 ZN	BUSHING 16,5 X35 X52 ZN	BOITE 16,5 X35 X52 ZN	BsCHSE 16,5 X35 X52 ZN	CASQUILLO 16,5 X35 X52 ZN
4	F01100011	INGRASS.A SFERE M6X1/A	SPHERE NIPPLE M6X1/A	GRAISSEUR A BILLES M6X1/A	KUGELFETTBSCHSE M6X1/A	ENGRAS. DE ESFERAS M6X1/A
5	17810970	SPINA ZN	PIN ZN	GOUPILLE ZN	BOLZENSTIFT ZN	PASADOR ZN
6	F02200397	COPIGLIA R 5X100 ZN	SPLIT PIN R 5X100 GALVANIZED	GOUPILLE R 5X100 ZN	SPLINT R 5X100 ZN	PASADOR R 5X100 ZN
7	17811120	DISCO CONTENIMENTO DX COMPL.	DISK ASSY. DX	DISQUE COMPL. DX	KOMPLETTE SCHEIBE DX	DISCO COMPLETO DX
8	F01020266	VITE 16X120 5737 8.G ZN	BOLT 16X120 5737 8.G GALVANIZ	VIS 16X120 5737 8.G ZN	SCHRAUBE 16X120 5737 8.G ZN	TORNILLO 16X120 5737 8.G ZN
9	17810810	LAMA AGGANCIAMENTO TUBO	TUBE COUPLER	ATTELAGE TUBE	KUPPLUNG ROHR	ENGANCHE TUBO
10	F01230085	DADO AUTOB.NOR.16 ZN	NORMAL SELF-LOCKING NUT 16 GAL	ECROU AUTOB. NOR. 16 ZN	MUTTER AUTOB.NOR.16 ZN	TUERCA AUTOB. NOR.16 ZN
11	F01020252	VITE 16X50 5737 8.G ZN	SCREW 16X50 5737 8.G GALVANIZ	VIS 16X50 5737 8.G ZN	SCHRAUBE 16X50 5737 8.G ZN	TORNILLO 16X50 5737 8.G ZN
12	F01230131	DADO AUTOB.NOR.20 ZN	NORMAL SELF-LOCKING NUT 20 GAL	ECROU AUTOB. NOR. 20 ZN	MUTTER AUTOB.NOR.20 ZN	TUERCA AUTOB. NOR.20 ZN
13	F01020316	VITE 20X130 5737 8.8 ZN	SCREW 20X130 5737 8.8 GALVAN.	VIS 20X130 5737 8.8 ZN	SCHRAUBE 20X130 5737 8.8 ZN	TORNILLO 20X130 5737 8.8 ZN
14	17811090	BRACCIO SUPPORTO DISCO DX	DISC ARM SUPPORT DX	SUPPORT BRAS DISQUE DX	HALTERUNG SCHEIBENARM DX	SOPORTE BRAZO DISCO DX
15	67002048	BOCCOLA DI BLOCCO	BLOCK BUSHING	BOITE DE ENSEMBLE	BLOCKBSCHSE	CASQUILLO DE BLOQUE
16	67002049	GRANO	GRUB--SCREW	GOUJON	STIFT	TORNILLO SIN CABEZA
17	67002047	TAPPO	CLOSURE TAP	BOUCHON DE FERMETURE	ABSCHLUSSPFROPFEN	TAPN DE CIERRE
18	67002046	DISCO DENTATO	TOOTHED DISK	DISQUE DENTE	VERZAHNTE SCHEIBE	DISCO DENTADO
19	67002045	SUPPORTO CUSCINETTI	BEARING SUPPORT	SUPPORT PALIER	LAGERB_CHSE	SOPORTE COJINETE
20	17810940	SUPPORTO DISCO SX	DISC SUPPORT SX	SUPPORT DISQUE SX	SCHEIBENHALTERUNG SX	SOPORTE DISCO SX
21	17811130	DISCO CONTENIMENTO SX COMPL.	DISK ASSY. SX	DISQUE COMPL. SX	KOMPLETTE SCHEIBE SX	DISCO COMPLETO SX
22	17811080	BRACCIO SUPPORTO DISCO SX	DISC ARM SUPPORT	SUPPORT BRAS DISQUE	HALTERUNG SCHEIBENARM	SOPORTE BRAZO DISCO

TAV. 980/780

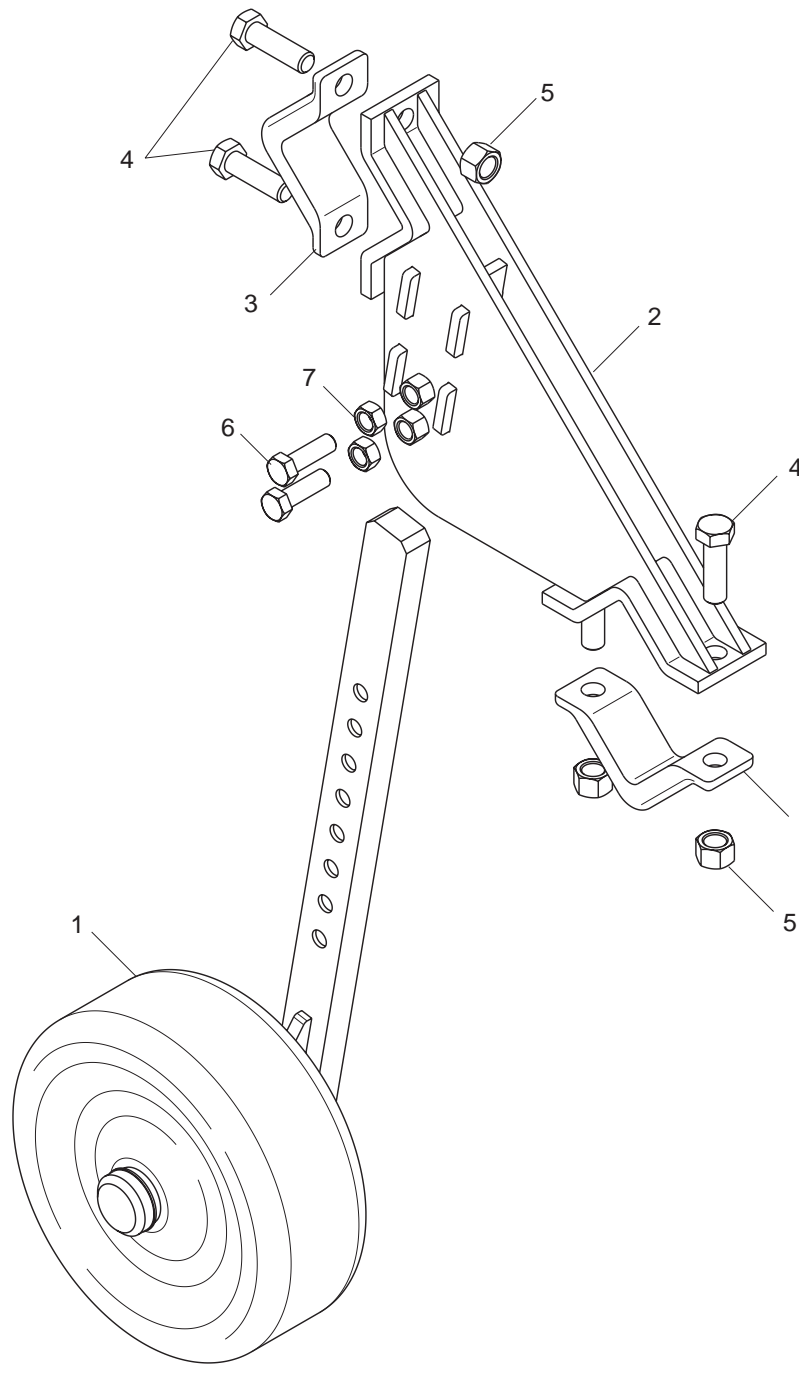

RUOTE DI SOSTEGNO

TAV. 980/780

Pos.	Cod.	Descrizione	Description	Description	Benennung	Descripcion
1	17812290	RUOTA DI PROFONDITA'	DEPTH WHEEL	ROUE DE PROFONDEUR	TIEFENRAD	RUEDA DE PROFUNDIDAD
2	17812320	SUPPORTO RUOTA DI PROFONDITA'	FROF. WHEEL SUPPORT	SUPPORT ROUE FROF.	HALTERUNG TIEFEN RAD	SOPORTE RUEDA FROF
3	17811170	SCONTRIO PER TUBO 100	STRIKER PLATE 100	BUTEE 100	ANSCHLAG 100	ELEMENTO DE EMPALME 100
4	F01020343	VITE 24X 80 5737 10.9 ZN	BOLT 24X80 5737 10.9G GALVANI	VIS 24X80 5737 10.9G ZN	SCHRAUBE 24X80 5737 10.9G ZN	TORNILLO 24X80 5737 10.9G ZN
5	F01230143	DADO AUTOB.NOR.24X2 ZN	NORMAL SELF-LOCK.NUT 24X2 GAL	ECROU AUTOB. NOR. 24X2 ZN	MUTTER AUTOB.NOR.24X2 ZN	TUERCA AUTOB. NOR.24X2 ZN
6	F01020308	VITE 20X65 5737 8.G ZN	BOLT 20X65 5737 8.G GALVANIZED	VIS 20X65 5737 8.G ZN	SCHRAUBE 20X65 5737 8.G ZN	TORNILLO 20X65 5737 8.G ZN
7	F01200352	DADO 20 5588 6.8 ZN	NUT 20 UNI 5588 6.8 GALVANIZED	ECROU 20 UNI 5588 6.8 ZN	MUTTER 20 UNI 5588 6.8 ZN	TUERCA 20 UNI 5588 6.8 ZN

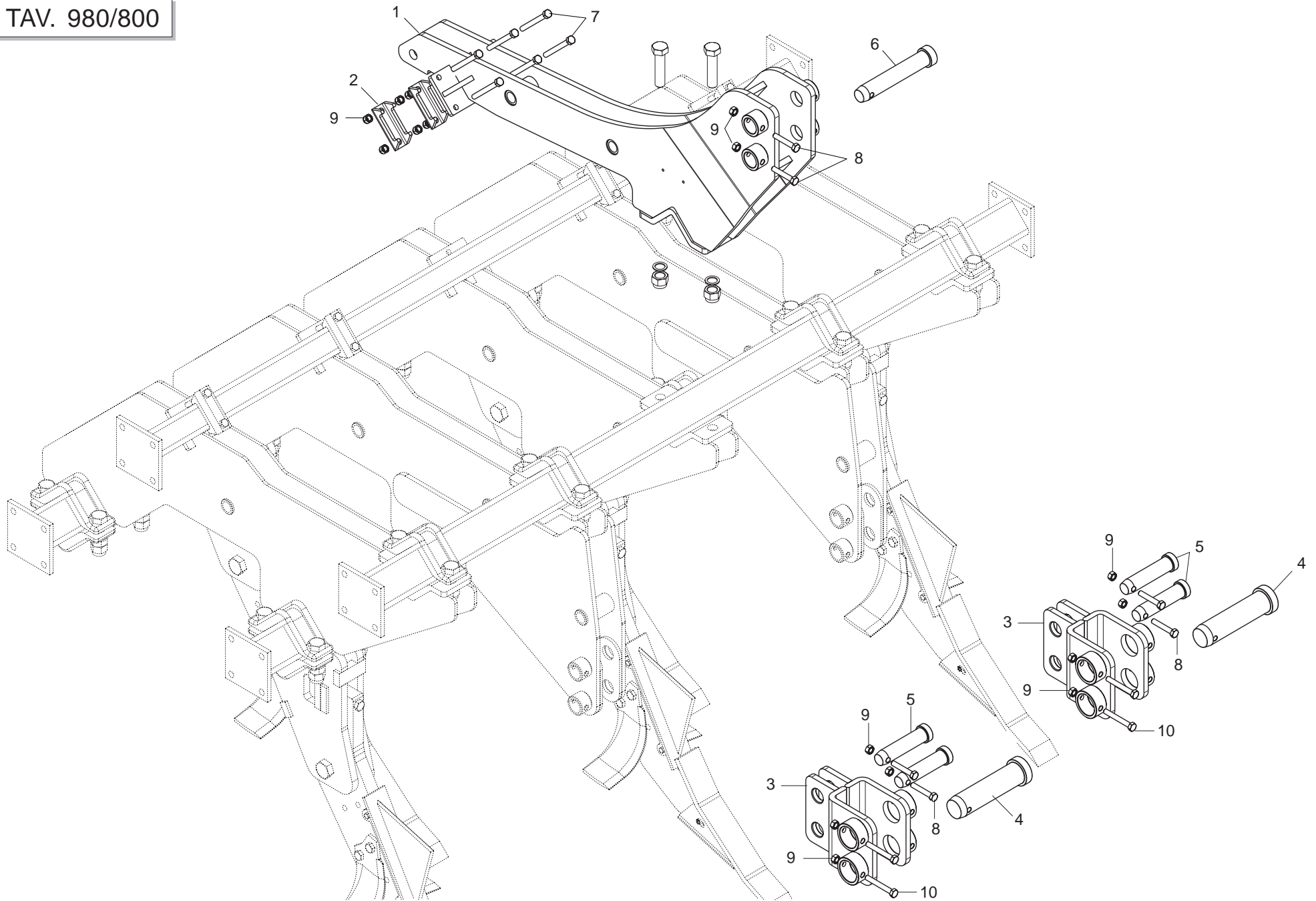

ATTACCO "IV" CATEGORIA

TAV. 980/800

Pos.	Cod.	Descrizione	Description	Description	Benennung	Descripcion
1	17812460	ATTACCO TERZO PUNTO	ATTACHMENT	FIXATION	ANSCHLUSS	CONEXIN
2	16740160	SCONTRO A U SP.8 2F13 83	U-SHAPED STOP TEETH B343SP.8 2	BUT+E EN U EP.8 2F13 83	U-ANSCHLAG SP.8 2F13 83	DIENTE DE PARADA A U ESP.8 2F1
3	17812380	ATTACCO 1-2 PUNTO	1.-2. POINT COUPLING	FIXATION 1.-2. POINT	KUPPLUNG 1. - 2. PUNKT	CONEXIN 1. - 2. PUNTO
4	17812390	SPINA GASPARDO 56X190	GASPARDO PIN 56X190	BROCHE GASPARDO 56X190	STIFT GASPARDO 56X190	CLAVIJA GASPARDO 56X190
5	F20100112	SPINA GASPARDO 36X134 ZN	GASPARDO PIN 36X134 ZN	BROCHE GASPARDO 36X134 ZN	STIFT GASPARDO 36X134 ZN	CLAVIJA GASPARDO 36X134 ZN
6	17812440	SPINA GASPARDO 39X200	GASPARDO PIN 39X200	BROCHE GASPARDO 39X200	STIFT GASPARDO 39X200	CLAVIJA GASPARDO 39X200
7	F01020174	VITE 12X120 5737 8.G ZN	BOLT 12X120 5737 8.G GALVANIZ.	VIS 12X120 5737 8.G ZN	SCHRAUBE 12X120 5737 8.G ZN	TORNILLO 12X120 5737 8.G ZN
8	F01020164	VITE 12X70 5737 8.G ZN	BOLT 12X70 5737 8.G GALVANIZED	VIS 12X70 5737 8.G ZN	SCHRAUBE 12X70 5737 8.G ZN	TORNILLO 12X70 5737 8.G ZN
9	F01220244	DADO TRISTOP M12	NUT- TRISTOP M12	ECROU TRISTOP M12	MUTTER TRISTOP M12	TUERCA TRISTOP M12
10	F01020344	VITE 24X100 5737 10.9 ZN	SCREW 24X100 5737 10.9 ZN	VIS 24X100 5737 10.9 ZN	SCHRAUBE 24X100 5737 10.9 ZN	TORNILLO 24X100 5737 10.9 ZN

**USATE SEMPRE RICAMBI ORIGINALI
ALWAYS USE ORIGINAL SPARE PARTS
IMMER DIE ORIGINAL-ERSATZTEILE VERWENDEN
EMPLOYEZ TOUJOURS LES PIECES DE RECHANGE ORIGINALES
UTILIZAR SIEMPRE REPUESTOS ORIGINALES**

GASPARDO

DEALER:

GASPARDO



19530483

GASPARDO Seminatrici SpA
Via Mussons, 7 - I - 33075
Morsano al Tagliamento (PN) Italy
Tel. +39 0434 695410
Fax +39 0434 695425
e-mail: gaspardo@gaspardo.it
<http://www.gaspardo.it>

MASCHIO DEUTSCHLAND GMBH
Äußere Nürnberger Straße 5
D - 91177 Thalmässing
Deutschland
Tel. +49 (0) 9173 79000
Fax +49 (0) 9173 790079

MASCHIO FRANCE Sarl
1, Rue de Mérignan ZA
F - 45240 La Ferte St. Aubin
France
Tel. +33 (0) 2.38.64.12.12
Fax +33 (0) 2.38.64.66.79

MASCHIO IBERICA S.L.
Calle Cabernet, 10
Poligono Industrial Clot de Moja
Olerdola - 08734 Barcelona
Tel. +34 93.81.99.058
Fax +34 93.81.99.059

MASCHIO USA
432 2ND Street
Rock Island, IL 61201 USA
Ph. +1 309 794-2310
Fax +1 309 788-1610

MASCHIO MIDDLE EAST S.L.
MASCHIO-GASPARDO ROMANIA S.R.L.
GASPARDO-MASCHIO TURCHIA
MASCHIO-GASPARDO CANADA Inc