

# GASPARDO

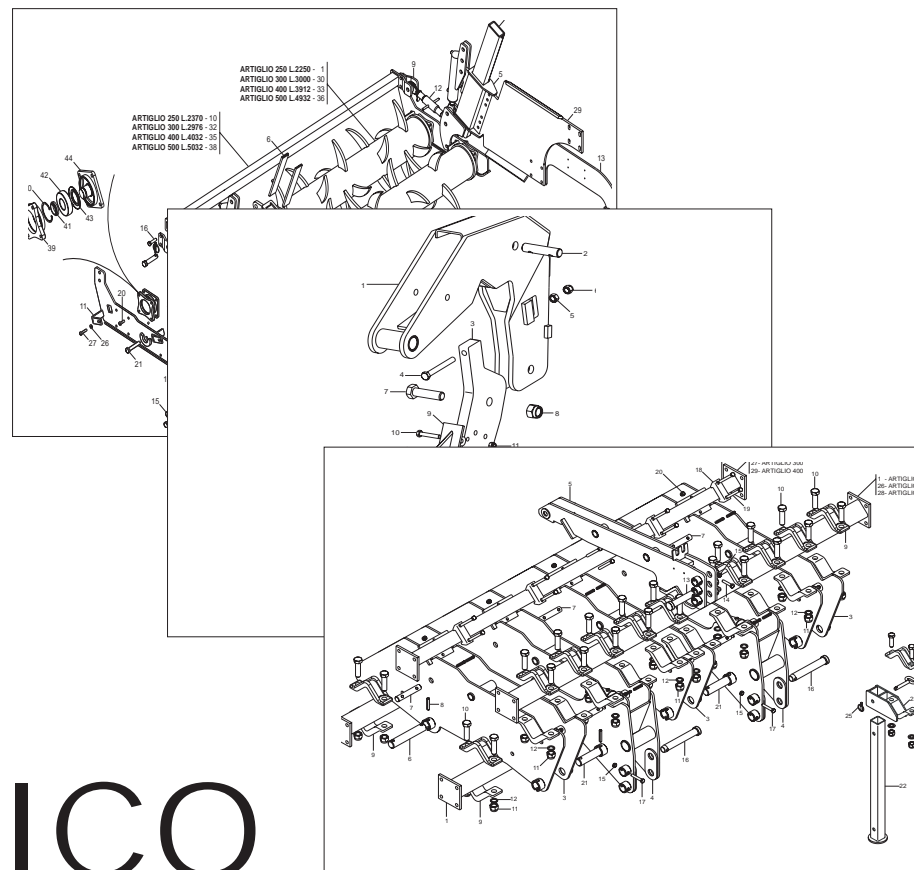

# ARTIGLIO IDROPNEUMATICO

Cod: R19530070 11 / 2006

# GASPARDO

- IT** PARTI DI RICAMBIO
- EN** SPARE PARTS
- DE** ERSATZTEILE
- FR** PIÈCES DÉTACHÉES
- ES** PIEZAS DE REPUESTO

**PARTI DI RICAMBIO****SPARE PARTS****ERSATZTEILE****PIECES DÉTACHÉES****RESPUESTOS**

Le ordinazioni delle parti di ricambio vanno fatte presso i nostri concessionari di zona e devono essere sempre corredate dalle seguenti indicazioni:

- **Tipo, modello e numero di matricola dell'attrezzatura.** Tali dati sono stampigliati nell'apposita targhetta di cui è dotata ogni attrezzatura.

- **Numero di codice della parte richiesta** rilevabile dal catalogo ricambi.

- **Descrizione del particolare e quantità richiesta.**

- **Numero della tavola.**

- **Mezzo di trasporto.** Nel caso questa voce non sia specificata, la Ditta Costruttrice, pur dedicando a questo servizio una particolare cura, non risponde di eventuali ritardi di spedizione dovuti a cause di forza maggiore.

Le spese di trasporto si intendono sempre a carico del destinatario. La merce viaggia a rischio e pericolo del committente anche se venduta franco destino.

**NOTA:** Il termine **(Dx) Destro** o **(Sx) Sinistro** della macchina o di parti di essa, è inteso guardando la macchina dalla parte posteriore. Le eccezioni saranno indicate.

*Orders must be transmitted through our area dealers and should always include the following indications:*

- **Type, model and serial number of the machine.** *These data are punched on the data plate with which every implement is equipped.*

- **Code number of the required spare part.** *This will be found in the spare parts catalogue.*

- **Description of the part and required quantity.**

- **Table number.**

- **Means of dispatch.** *If this item is not indicated, the Manufacturer, while dedicating particular care to this service, shall not be held responsible for delays in delivery caused by cases of force majeure.*

*Transport expenses shall always be at the consignee's charge. The goods travel at the purchaser's risk and peril even when sold ex destination.*

**NOTE:** *The symbols (Dx) right and (Sx) left, concerning the machine or single parts of it, are referred, as in the figure, to a rear view of them. Exceptions will be indicated.*

Die Bestellungen müssen bei unseren Gebietshändler aufgegeben werden. Bei der Bestellung sind stets die folgenden Angaben zu machen:

- **Typ, Modell und Serien-Nummer des Geräts.** Diese Daten stehen auf dem Typenschild, mit dem jedes Gerät versehen ist.

- **Artikel Nr. der erforderlichen Ersatzteile.** Diese stehen im Ersatzteil-Katalog.

- **Beschreibung des Ersatzteils und die erforderliche Stückzahl.**

- **Tafelnummer.**

- **Versandmittel.** Wenn dieser Punkt nicht spezifiziert wird, haftet die Herstellerfirma nicht für etwaigen Lieferverzug aufgrund höherer Gewalt, auch wenn er diesen Service besonders aufmerksam abwickelt. Die Frachtkosten gehen dagegen immer zu Lasten des Empfängers. Die Ware reist auf Gefahr und Risiko des Auftraggebers, auch wenn frei Haus Verkauft vereinbart worden ist.

**N.B.:** Die Merkzeichen **(Dx) rechts** und **(Sx) links** betreffen eine rückwärtige Aussicht der Maschine oder Teile von ihr (siehe Bild). Ausnahmen werden gezeigt.

*Les ordres doivent être effectués auprès de nos concessionaires de zone en précisant les indications suivantes:*

- **Type, modèle et numéro de série de la machine.** *Ces données sont gravées sur la plaque d'identification de chaque outil.*

- **Numéro de code de la pièce détachée** *indiqué sur le catalogue des pièces détachées.*

- **Description de la pièce et quantité requise.**

- **Numéro de plan.**

- **Moyen d'expédition.** *Si cette rubrique n'est pas indiquée, le Constructeur, bien que soucieux de ce service, ne répond pas des retards d'expédition pour des causes de force majeure.*

*Les frais de transport sont toujours à la charge du destinataire. La marchandise voyage aux risques et périls de l'acheteur même si vendue franco de port.*

**N.B.:** *Les références (Dx) droit et (Sx) gauche de la machine ou des parties de la même, est entendue, comme de la figure, en regardant la machine de derriere dans le sens de marche.*

Los pedidos han de efectuarse en nuestros consesionarios de zona y deben incluir siempre las siguientes indicaciones:

- **Tipo, modelo y número de matricula del equipo.** Dichos datos están impresos en la relativa placa presente en el equipo.

- **Número de código de la parte requerida** presente en el catálogo respuestas.

- **Descripción de la pieza y cantidad requerida.**

- **Numero de ilustración.**

- **Medio de transporte.** En caso que este ítem no esté especificado, el Fabricante, aún prestando la debidas consideraciones para este aspecto, no responde por eventuales retardos de env'o debidos a causas de fuerza mayor. Los gastos de transporte se consideran siempre a cargo del destinatario. La mercadería viaja bajo riesgo y peligro del comprador, incluso cuando se vende franco destino.

**N.B.:** La refencia **(Dx) derecha** o **(Sx) izquierda** de la máquina o de sus componentes, se entiende, como en la figura, mirando la máquina por la parte trasera. Se indicarán las excepciones.

<b><i>Nr. Tav.</i></b>	<b><i>Descrizione - Description</i></b>	<b><i>Pag.</i></b>
TAV. 010	Telaio	4
TAV. 020	Ancora	6
TAV. 030	Impinato idropneumatico	8
TAV. 040	Doppio rullo posteriore	10
TAV. 050	Impianto oleodinamico	12
TAV. 060	Bandinelle laterali	14
TAV. 070	Dischi di contenimento	16
TAV. 080	Ruote di sostegno	18
TAV. 090	Attacco "IV" categoria	20
TAV. 100	Attacco "III" e "IV" categoria	22

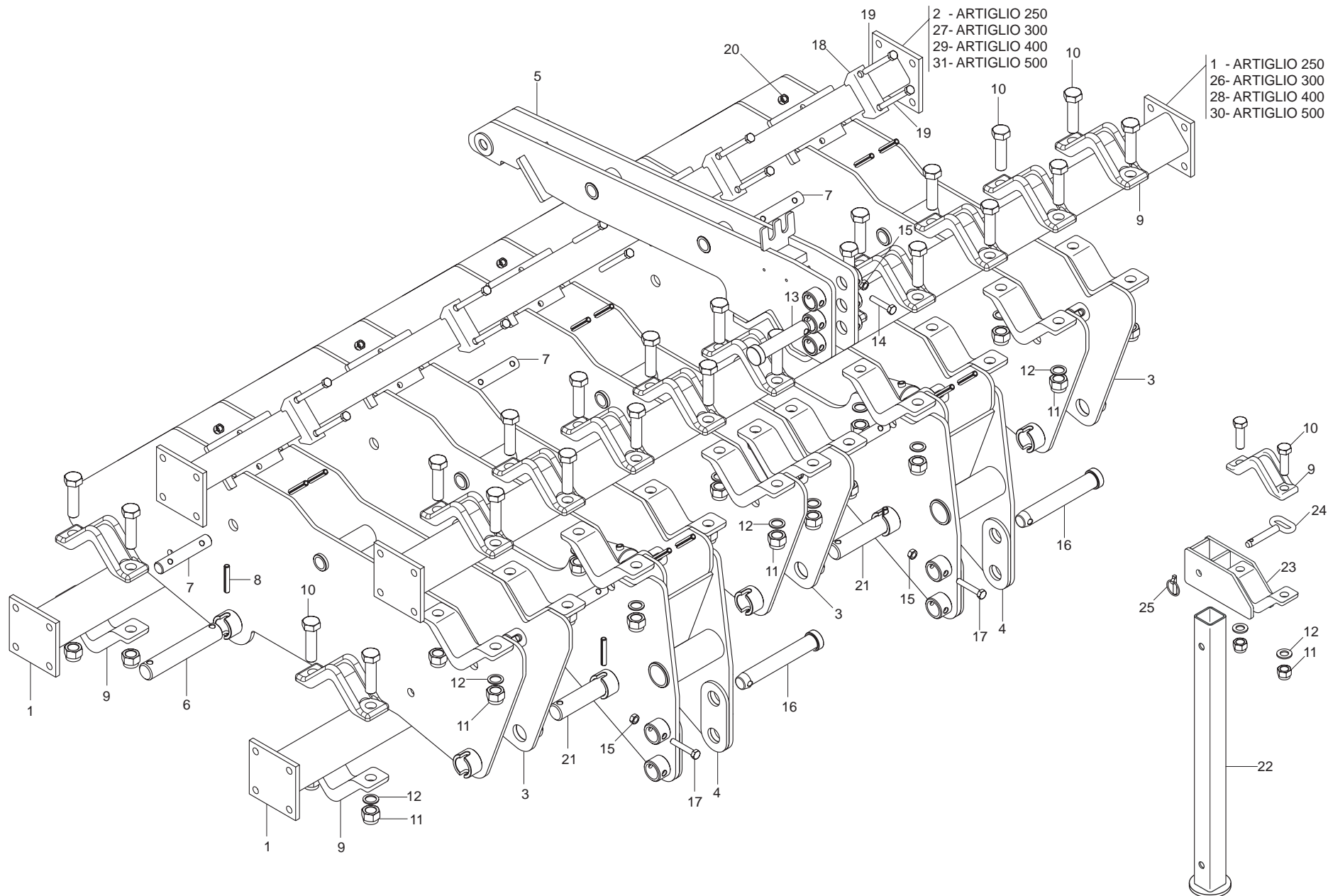

**TELAIO**

**TAV. 010**

Pos.	Cod.	Descrizione	Description	Description	Benennung	Descripcion
1	R17810141	TELAIO ANTERIORE 2370	FRAME FRONT 2370	BATI AVANT 2370	VORDERRAHMEN 2370	BASTIDOR DELANTERO 2370
2	R17810172	TELAIO POSTERIORE 2370	MAIN FRAME 2370	BATI ARRIERE 2370	HINTERRAHMEN 2370	BASTIDOR TRASERO 2370
3	R17815610	ASS.TELAIO	FRAME SUPPORT	SUPPORT CH_SSI	RAHMENHALTERUNG	SOPORTE BASTIDOR
4	R17815520	ASS.TELAIO CENTRALE	FRAME SUPPORT	SUPPORT CH_SSI	RAHMENHALTERUNG	SOPORTE BASTIDOR
5	#N/A	#N/A	#N/A	#N/A	#N/A	#N/A
6	R17814080	PERNO	PIN	PIVOT	BOLZEN	PERNO
7	R17814070	PERNO	PIN	PIVOT	BOLZEN	PERNO
8	F02100180	SPINA E.P. 12X 70 U6873 C70 BR	ELASTIC PIN 12X70 DIN 1481	GOIJON ELASTIQUE 12X70	SPANNHUELSE 12x70 DIN 1481	ESPINA ELASTICA 12X70 DIN 1481
9	R17811170	SCONTRO PER TUBO 100	STRIKER PLATE 100	BUTEE 100	ANSCHLAG 100	ELEMENTO DE EMPALME 100
10	F01020343	VITE M24X 3X 80 U5737 10.9 ZB	BOLT M24X 3X 80 U5737 10.9 ZB	VIS M24X 3X 80 U5737 10.9 ZB	SCHR.M24X 3X 80 U5737 10.9 ZB	TORN.M24X 3X 80 U5737 10.9 ZB
11	F01230144	DADO AUTOB.NORM.24 ZB	SELF-LOCKING NUT NORM.24 ZB	ECROU AUTOB.NORM.24 ZB	SELBSTSPERR. MUTTER NORM.24 ZB	TUERCA AUTOB .NORM.24 ZB
12	G18701590	RONDELLA 25X35X2,5 ZB	WASHER 25 x 35 x2,5 ZB	RONDELLE 25 x 35 x2,5 ZB	UNTERLEGSSCHEIBE 25 x 35 x2,5	ARANDELA 25 x 35 x2,5 ZB
13	#N/A	#N/A	#N/A	#N/A	#N/A	#N/A
14	F01020160	VITE M12X1,75X60 U5737 8.8 ZG	BOLT M12X1,75X60 U5737 8.8 ZG	VIS M12X1,75X60 U5737 8.8 ZG	SCHRAUBE M12X1,75X60 U5737 8.8	TORNILLO M12X1,75X60 U5737 8.8
15	F01220244	DADO TRISTOP M12	NUT- TRISTOP M12	ECROU TRISTOP M12	MUTTER TRISTOP M12	TUERCA TRISTOP M12
16	R17816580	SPINA D36 ZB	PIN D36 ZB	BROCHE D36 ZB	STIFT D36 ZB	CLAVIJA D36 ZB
17	F01020164	VITE M12X1,75X70 U5737 8.8 ZB	BOLT M12X1,75X70 U5737 8.8 ZB	VIS M12X1,75X70 U5737 8.8 ZB	SCHR.M12X1,75X70 U5737 8.8 ZB	TORN.M12X1,75X70 U5737 8.8 ZB
18	G16740160	SCONTRO A U SP.8 2F13 83	U-SHAPED STOP TEETH B343SP.8	BUTEE EN U SP.8 2F13 83	U-ANSCHLAG SP.8 2F13 83	DIENTE DE PARADA A U ESP.8
19	F01020174	VITE 12X120 5737 8.8 ZN	BOLT 12X120 5737 8.8 GALVANIZ.	VIS 12X120 5737 8.8 ZN	SCHRAUBE 12X120 5737 8.8 ZN	TORNILLO 12X120 5737 8.8 ZN
20	F01230059	DADO M12X1,75 D982 8 ZB	NUT M12X1,75 D982 8 ZB	ECRO.M12X1,75 D982 8 ZB	MUTT.M12X1,75 D982 8 ZB	TUER.M12X1,75 D982 8 ZB
21	R17816570	SPINA D40 L220 ZB	PIN D40 L220 ZB	BROCHE D40 L220 ZB	STIFT D40 L220 ZB	CLAVIJA D40 L220 ZB
22	R17810380	PUNTELLO	PROP	ETRESILLON	STUTZE	PUNTAL
23	R17810411	SUPPORTO PUNTELLO	PROP SUPPORT	SUPPORT ETRESILLON	STUTZENHALTERUNG	SOPORTE PUNTAL
24	R17810440	PERNO ZN	PIN ZN	PIVOT ZN	BOLZEN ZN	PERNO ZN
25	F02200507	PINA SCATTO D. 9 B/83 ZG	SNAP PIN D 9 B/83	FICHE A DETENTE D 9 B/83	EINRASTSTIFT D 9 B/83	CLAVIJA DE MUELLE D 9 B/83
26	R17810460	TELAIO ANTERIORE 3000	FRAME FRONT 3000	BATI AVANT 3000	VORDERRAHMEN 3000	BASTIDOR DELANTERO 3000
27	R17810481	TELAIO POSTERIORE 3000	MAIN FRAME 3000	BATI ARRIERE 3000	HINTERRAHMEN 3000	BASTIDOR TRASERO 3000
28	R17816410	TUBO 4M L.4032	PIPE 4M L.4032	TUBE 4M L.4032	ROHR 4M L.4032	TUBO 4M L.4032
29	R17816430	TUBO 4M L.4032	PIPE 4M L.4032	TUBE 4M L.4032	ROHR 4M L.4032	TUBO 4M L.4032
30	R17816350	TUBO 5M L.4944	PIPE 5M L.4944	TUBE 5M L.4944	ROHR 5M L.4944	TUBO 5M L.4944
31	R17816390	TUBO 5M L.4944	PIPE 5M L.4944	TUBE 5M L.4944	ROHR 5M L.4944	TUBO 5M L.4944

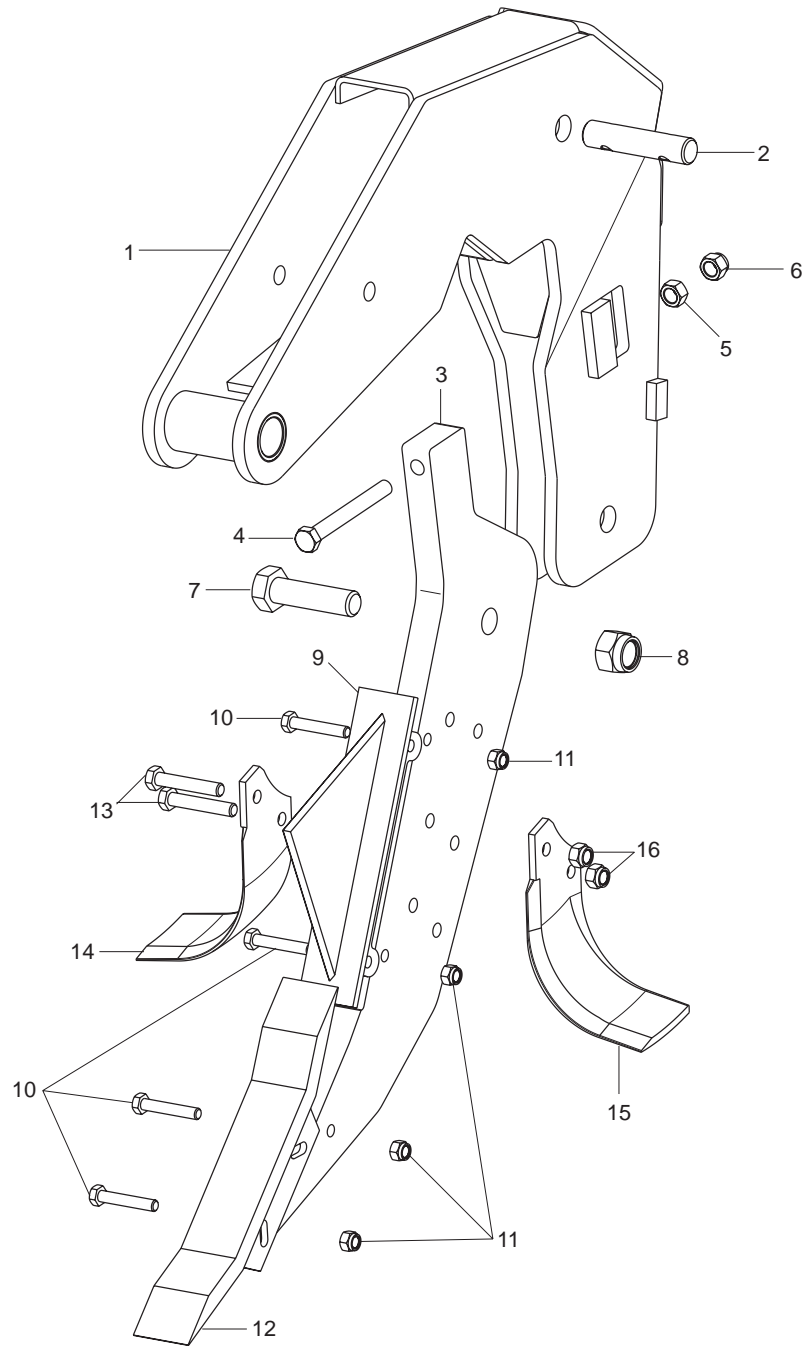

**ANCORA**

**TAV. 020**

Pos.	Cod.	Descrizione	Description	Description	Benennung	Descripcion
1	R17816600	SUPPORT PUNTALE	SUPPORT FOR EARTH-OPENING BLAD	SUPPORT EMBOUT	MESSERHALTER	SOPORTE PUNTAL
2	R17814060	PERNO	PIN	PIVOT	BOLZEN	PERNO
3	R17820440	LAMA PUNTALE	TIP	EMBOUT	STUTZE	PUNTAL
4	F01020269	VITE M16X 2X140 U5737 8.8 ZG	BOLT M16X 2X140 U5737 8.8 ZG	VIS M16X 2X140 U5737 8.8 ZG	SCHRAUBE M16X 2X140 U5737 8.8	TORNILLO M16X 2X140 U5737 8.8
5	F01260047	DADO FLANG.M16 D6923 8.8 ZG	NUT M16 D6923 8.8 ZG	ECROU M16 D6923 8.8 ZG	MUTTER M16 D6923 8.8 ZG	TUERCA M16 D6923 8.8 ZG
6	F01200321	DADO M16X 2 U5588 6.8 ZG	NUT M16X2	ECROU M16X2	MUTTER M16X2	DADO M16X2
7	F01061000	VITE M27X 3X110 U5712 10.9 ZG	SCREW 27X110 5712 10.9 ZN	VIS 27X110 5712 10.9 ZN	SCHRAUBE 27X110 5712 10.9 ZN	TORNILLO 27X110 5712 10.9 ZN
8	F01230150	DADO AUTOB.NORM.27 ZN	SELF-LOCKING NUT NORM.27 ZN	ECROU AUTOB.NORM.27 ZN	SELBSTSPERR. MUTTER NORM.27 ZN	TUERCA AUTOB. NORM.27 ZN
9	#N/A	#N/A	#N/A	#N/A	#N/A	#N/A
10	F01020164	VITE M12X1,75X70 U5737 8.8 ZB	BOLT M12X1,75X70 U5737 8.8 ZB	VIS M12X1,75X70 U5737 8.8 ZB	SCHR.M12X1,75X70 U5737 8.8 ZB	TORN.M12X1,75X70 U5737 8.8 ZB
11	F01230059	DADO M12X1,75 D982 8 ZB	NUT M12X1,75 D982 8 ZB	ECRO.M12X1,75 D982 8 ZB	MUTT.M12X1,75 D982 8 ZB	TUER.M12X1,75 D982 8 ZB
12	R17820660	DENTE ARTIG.Zgancio Rapido Rev	TOOTH DENT ARTIG.Quick Fit Rev	EMBOUT GRIFFE ARTIG.	ZAHN KLAUESTUTZE ARTIG.	DIENTE PUNTAL GARRA
13	F01020210	VITE M14X 2X 80 U5737 8.8 ZG	BOLT M14X 2X 80 U5737 8.8 ZG	VIS M14X 2X 80 U5737 8.8 ZG	SCHRAUBE M14X 2X 80 U5737 8.8	TORNILLO M14X 2X 80 U5737 8.8
14	R17820850	ZAPPA ELICA DESTRA	RIGHT HELICOIDAL BLADE	LAME HELICE B-C-SC DRT	RECHTES BOGENMESSER	AZADA HELICE DERECHA
15	R17820840	ZAPPA ELICA SINISTRA	LEFT HELICOIDAL BLADE	LAME HELICE B-C-SC GCH	LINKES BOGENMESSER	AZADA HELICE IZQUIERDA

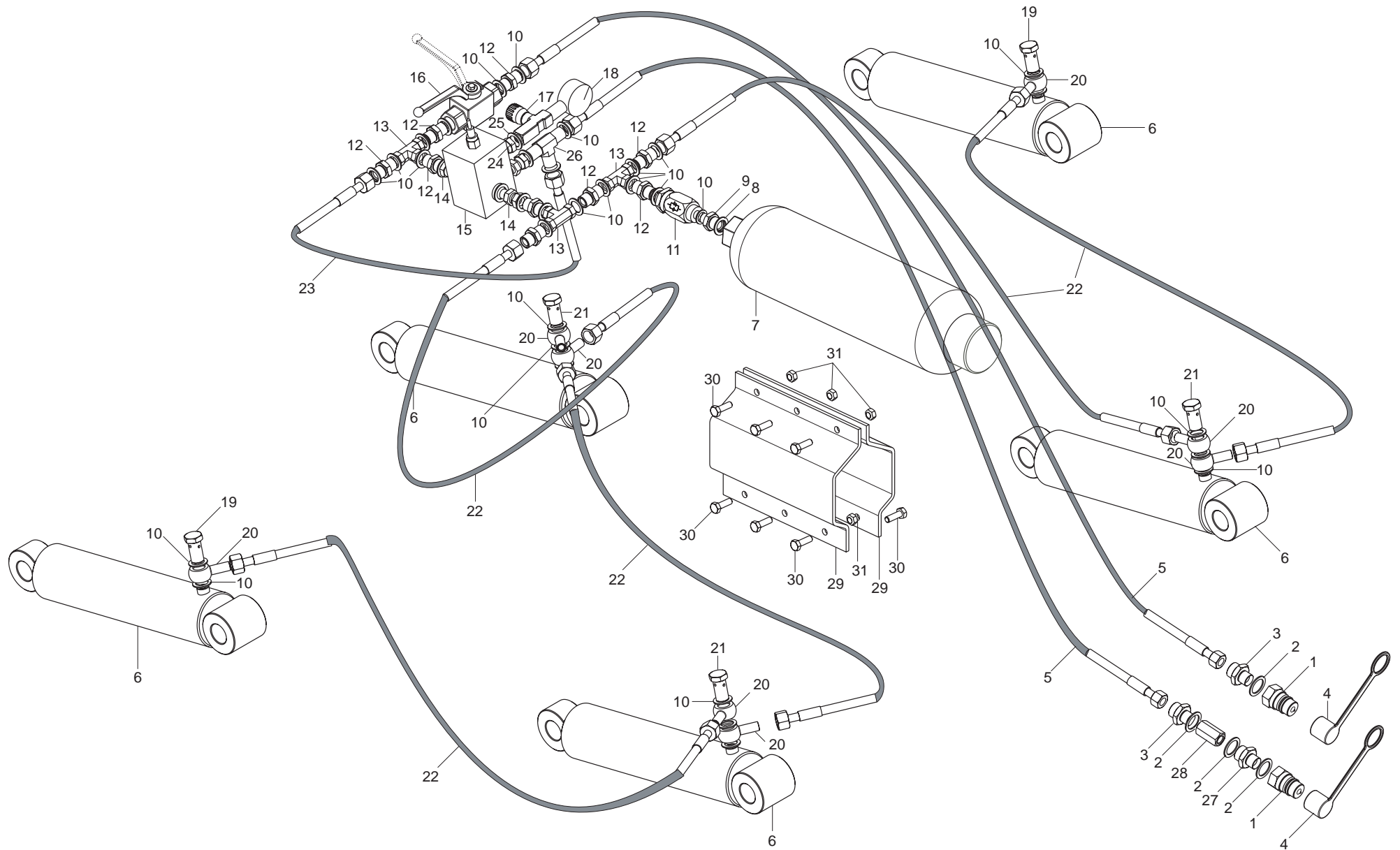



**IMPIANTO IDROPNEUMATICO**
**TAV. 030**

Pos.	Cod.	Descrizione	Description	Description	Benennung	Descripcion
1	F03150935	INNESTO RAP.MASCH.1/2 A VALV.	QUICK CONNECT MALE CONE 1/2 CO	CONNEXION RAPIDE MALE CONE 1/2	SCHNELLKUPPLUNG GEWINDE KONISC	ACOPLAMIENTO RAPIDO MACHO CONO
2	F03151237	RONDELLA RAME 21X27X1,5 -1/2"	1/2 COPPER WASHER	RONDELLE CUIVRE 1/2	UNTERLEGSCHIEBE KUPFER 1/2	ARANDELA COBRE 1/2
3	F03150222	NIPPLO MASCHIO 1/2-3/8 ZINC.	NIPPLE- GALVAN. CYLINDR.MALE-	NIPPLE MALE 1/2-3/8 ZING.	NIPPEL 1/2-3/8 VERZINKT	NIPLE MACHO 1/2-3/8 CINC.
4	F05150325	CAPPUCCIO INNESTO 1/2	COVER 1/2	COUVERCLE 1/2	DECKEL 1/2	TAPA 1/2
5	G15312601	TUBO 3/8 R2 F3/8-F3/8 L.2000	PIPE 3/8 R2 F3/8-F3/8 L.2000	TUBE 3/8 R2 F3/8-F3/8 L.2000	ROHR 3/8 R2 F3/8-F3/8 L.2000	TUBO 3/8 R2 F3/8-F3/8 L.2000
6	R17814560	CILINDRO	CYLINDER	CYLINDRE	ZYLINDER	CILINDRO
7	F03151265	ACCUMULATORE AZOTO 2,8L 250BAR	HST ACCUMULATOR 2,8L 250BAR	ACCUMULATOR HST 2,8L 250BAR	AKKUMULATOR HST 2,8L 250BAR	ACUMULADOR HST 2,8L 250BAR
8	F03151239	RONDELLA RAME 3/4	3/4 COPPER WASHER	RONDELLE CUIVRE 3/4	UNTERLEGSCHIEBE KUPFER 3/4	ARANDELA COBRE 3/4
9	#N/A	#N/A	#N/A	#N/A	#N/A	#N/A
10	F03151240	RONDELLA RAME 3/8	3/8 COPPER WASHER	RONDELLE CUIVRE 3/8	UNTERLEGSCHIEBE KUPFER 3/8	ARANDELA COBRE 3/8
11	F03151252	STROZZATORE BIDIREZ.VSRB 3/8	BI-DIRECTIONAL VENTURI 3/8	ETRANGLEUR BIDIRECTIONN. 3/8	ZWEIS. DROSSEL	ESTRANGULADOR BIDIRECCIONAL 3/8
12	F03150321	NIPPLO MM CIL-CIL 3/8-3/8 ZG	NIPPLE- GALVAN. CYLINDR.MALE-	NIPPLE MALE 3/8-MALE 3/8	NIPPEL 3/8- 3/8	NIPLE MACHO 3/8-MACHO 3/8
13	F03151266	RACCORDO -T- FEMMINA 3/8 ZINC.	UNION -T- F 3/8 ZINC.	RACCORD -T- F 3/8 ZINC.	ANSCHLUSSTsCK -T- F 3/8 ZINC.	UNIN -T- F 3/8 ZINC.
14	F03150067	NIPPLO M-F GIREVOLE 3/8 ZINC.	NIPPLE M-F SWIVEL 3/8 ZINC.	NIPPLE M-F TOURNANT 3/8 ZING.	NIPPEL M-F DREHBAR 3/8 VERZINK	NIPLE M-H GIRATORIO 3/8 CINC.
15	F03150593	VALVOLA VMP 3/8	VALVES VMP 3/8	CLAPET VMP 3/8	VENTIL VMP 3/8	VALVULA VMP 3/8
16	F03151246	RUBINETTO F-F 3/8	BREATHER TAP F-F 3/8	BOUCHON REFOUL. F-F 3/8	ENTLsFTUNGSPFROPFEN F-F 3/8	TAPON PURGADOR F-F 3/8
17	F03151267	RUBINETTO 1/4 COD.3232	BREATHER TAP 1/4 COD.3232	BOUCHON REFOUL. 1/4 COD.3232	ENTLsFTUNGSPFROPFEN 1/4 3232	TAPON PURGADOR 1/4 COD.3232
18	F03151164	MANOMETRO B.G. DA 0 A 250 BAR	PRESSURE GAUGE B.G.0-250 BAR	MANOMETRE B.G. 0-250 BAR	MANOMETER B.G. DA 0 A 250 BAR	MANMETRO B.G. 0-250 BAR
19	F03151223	RACCORDO VITE CAVA 3/8	UNION BOLT HOLLOW 3/8	RACCORD VIS CREUSE 3/8	ANSCHLUSS GEWINDEHOHLSCHR.3/8	UNIN TORNILLO RANURA 3/8 R
20	F03151269	OCCHIO FILETTATO 3/8-3/8	UNION BOLT HOLLOW 3/8-3/8	RACCORD VIS CREUSE 3/8-3/8	ANSCHLUSS GEWINDEHOHLSCHR 3/8	UNIN TORNILLO RANURA 3/8-3/8
21	F03151224	RACCORDO VITE CAVA 3/8 8 FORI	UNION BOLT HOLLOW 3/8	RACCORD VIS CREUSE 3/8	ANSCHLUSS GEWINDEHOHLSCHR.3/8	UNIN TORNILLO RANURA 3/8 R
22	R17814610	TUBO 3/8 R2 F3/8-F3/8 L.1650	PIPE 3/8 R2 F3/8-F3/8 L.1650	TUBE 3/8 R2 F3/8-F3/8 L.1650	ROHR 3/8 R2 F3/8-F3/8 L.1650	TUBO 3/8 R2 F3/8-F3/8 L.1650
23	G15316320	TUBO SAE 100 R2 F-F 3/8 L.900	PIPE SAE 100 R2 F-F 3/8 L.900	TUBE SAE 100 R2 F-F 3/8 L.900	ROHR SAE 100 R2 F-F 3/8 L.900	TUBO SAE 100 R2 F-F 3/8 L.900
24	F03151268	RIDUZIONE 3/8"M - 1/4"F	NIPPLE 3/8"M - 1/4"F	RACCORD FILETE 3/8"M - 1/4"F	REDUKTIONM 3/8"M - 1/4"F	REDUCCION 3/8"M - 1/4"F
25	F03151238	RONDELLA RAME 13X19X1,5 -1/4"	1/4 COPPER WASHER	RONDELLE CUIVRE 1/4	UNTERLEGSCHIEBE KUPFER 1/4	ARANDELA COBRE 1/4
26	F03151220	RACCORDO -T- 3/8 ZN	MALE T-UNION 3/8 ZINC.	RACCORD -T- MALE 3/8 ZING.	ANSCHLUSSTsCK -T- GEWINDE 3/8	UNIN -T- MACHO 3/8 CINC. R
27	F03150255	NIPLU TATA CIL.1/2-1/2 ZN	NIPLE 1/2"GAS	NIPLE 1/2"GAS	NIPLE 1/2"GAS	NIPLE 1/2"GAS
28	F03150576	VALVOLA UNID.IN LINEA 1/2	UNIDIRECTIONAL VALVE 1/2'	SOUPAPE UNIDIRECTIONNELLE 1/2'	SPERVENTIL 1/2'	VæLVULA UNIDIRECCINAL 1/2" V
29	R17815270	SUPPORTO ACCUMULATORE AZOTO	SUPPORT HST.ACCUMULATOR	SUPPORT ACCUMULATEUR HST.	HALTERUNG AKKUMULATOR HST.	SOPORTE ACUMULADOR HST.
30	F01020440	VITE M 8X1,25X25 U5739 8.8 ZG	BOLT M8 X25 5739 8.8 ZN	VIS M8 X25 5739 8.8 ZN	SCHRAUBE M8 X25 5739 8.8 ZN	TORNILLO M8 X25 5739 8.8 ZN
31	F01220222	DADO TRISTOP M 8	NUT- TRISTOP M 8	ECROU TRISTOP M 8	MUTTER TRISTOP M 8	TUERCA TRISTOP M 8

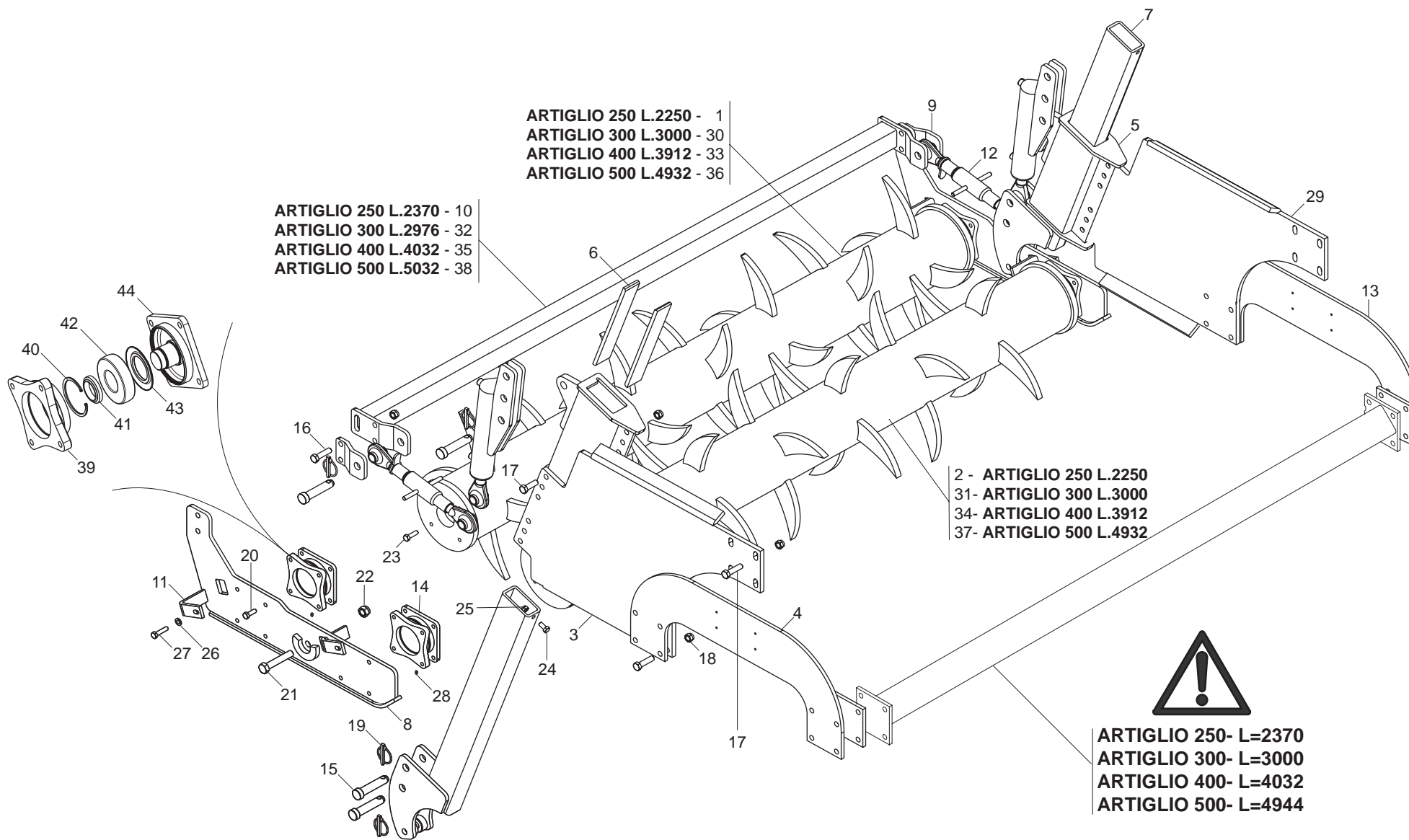

Pos.	Cod.	Descrizione	Description	Description	Benennung	Descripcion
1	R17811181	ASS.RULLO 2,5 32 DENTI L=2250	ROLLER 32 TEETH 2,5 L=2250	ROULEAU A 32 DENTS 2,5 L=2250	32 ZAHN ROLLE 2,5 L=2250	RODILLO 32 DIENTES 2,5 L=2250
2	R17811191	ASS.RULLO 2,5 28 DENTI L=2250	ROLLER 32 TEETH 2,5 L=2250	ROULEAU A 28 DENTS 2,5 L=2250	28 ZAHN ROLLE 2,5 L=2250	RODILLO 28 DIENTES 2,5 L=2250
3	R17815750	LAMA SUPPORTO REGOLAZIONE	SUPPORT BLADE ADJUSTMENT	SUPPORT LAME REGLAGE	HALTERUNG MESSER	CUCHILLA SOPORTE
4	R17811270	LAMA DI RINFORZO	BLADE REINFORCEMENT	LAME RENFORCEMENT	MESSER VERSTZRKUNG	CUCHILLAS REFUERZO
5	R17811320	SUPPORTO SCORRIMENTO RULLI	ROLLER SUPPORT SLIDING	SUPPORT DE GLISSEMENT ROULEAU	HALBGLEITHALTERUNG	SOPORTE DE DESPLAZAMIENTO
6	R17811331	LAMA DI SCORRIMENTO	BLADE SLIDING	LAME DE GLISSEMENT	GLEITMESSER	CUCHILLAS DE DESPLAZAMIENTO
7	R17811370	LEVA SCORRIMENTO RULLI	LEVER SLIDING	LEVIER DE GLISSEMENT	GLEITHEBEL	PALANCA DE DESPLAZAMIENTO
8	R17811402	SUPPORTO RULLO	ROLLER SUPPORT	SUPPORT ROULEAUX	RIEMENSPANNERROLLEN	SOPORTE RODILLOS
9	R17811410	LAMA DI ATTACCO	BLADE	LAME	MESSER	CUCHILLA
10	R17811431	PROTEZIONE	GUARD	PROTECTION	SCHUTZ	PROTECIÉN
11	R17811450	RASCHIATERRA	SOIL SCRAPER	RACLEUR	ERDSCHABER	RASCADOR DE TIERRA
12	R17811490	TIRANTE TERZO PUNTO	3° POINT TIE ROD	TRINGLE 3° POINT	SPANNSTANGE 3° PUNKT	TIRANTE 3° PUNTO
13	R17810160	SCONTRO 145X145-12 4F17 105	STRIKER PLATE 145X145	BUTEE 145X145	ANSCHLAG 145X145	ELEMENTO DE EMPALME 145X145
14	R17015300	ASSIEME CUSCINETTO	BEARING SUPPORT	SUPPORT ROULEMENT	LAGERHALTERUNG	SOPORTE COJINETE
15	F20100063	PERNO D25 L113 C40	PIN GASPARDO D25 L113 C40	PIVOT GASPARDO D25 L113 C40	BOLZEN GASPARDO D25 L113 C40	PERNO GASPARDO D25 L113 C40
16	F01020256	VITE M16X 2X 60 U5737 8.8 ZB	BOLT M16X 2X 60 U5737 8.8 ZB	VIS M16X 2X 60 U5737 8.8 ZB	SCHR.M16X 2X 60 U5737 8.8 ZB	TORN.M16X 2X 60 U5737 8.8 ZB
17	F01020252	VITE M16X 2X 50 U5737 8.8 ZB	BOLT M16X 2X 50 U5737 8.8 ZB	VIS M16X 2X 50 U5737 8.8 ZB	SCHR.M16X 2X 50 U5737 8.8 ZB	TORN.M16X 2X 50 U5737 8.8 ZB
18	F01230085	DADO M16X 2 D982 8 ZB	NUT M16X 2 D982 8 ZB	ECROU M16X 2 D982 8 ZB	MUTT.M16X 2 D982 8 ZB	TUER.M16X 2 D982 8 ZB
19	F02200507	PINA SCATTO D. 9 B/83 ZG	SNAP PIN D 9 B/83	FICHE A DETENTE D 9 B/83	EINRASTSTIFT D 9 B/83	CLAVIJA DE MUELLE D 9 B/83
20	F01010288	VITE M12X1,25X35 U5740 8.8 ZB	SCREW M12X1,25X35 U5740 8.8 ZB	VIS M12X1,25X35 U5740 8.8 ZB	SCHR.M12X1,25X35 U5740 8.8 ZB	TORN.M12X1,25X35 U5740 8.8 ZB
21	F01020313	VITE M20X2,5X110 U5737 8.8 ZG	BOLT 20X110 5737 8.8 GALVANIZ.	VIS 20X110 5737 8.8 ZN	SCHRAUBE 20X110 5737 8.8 ZN	TORNILLO 20X110 5737 8.8 ZN
22	F01230131	DADO M20X 2,5 D982 6 ZB	NUT M20X 2,5 D982 6 ZB	ECRO.M20X 2,5 D982 6 ZB	MUTT.M20X 2,5 D982 6 ZB	TUER.M20X 2,5 D982 6 ZB
23	F01020528	VITE M12X1,75X40 U5739 10.9 ZG	SCREW 12X40 5739 10.9 ZN	VIS 12X40 5739 10.9 ZN	SCHRAUBE 12X40 5739 10.9 ZN	TORNILLO 12X40 5739 10.9 ZN
24	F01020508	VITE M12X1,75X25 U5739 8.8 ZG	BOLT M12X25	VIS M 12 X 25	SCHRAUBE M 12 X 25	TORNILLO M 12 X 25
25	F01230059	DADO M12X1,75 D982 8 ZB	NUT M12X1,75 D982 8 ZB	ECRO.M12X1,75 D982 8 ZB	MUTT.M12X1,75 D982 8 ZB	TUER.M12X1,75 D982 8 ZB
26	F01410076	RONDELLA D12 UNI 6592 ZN	PLANE WASHER D12 UNI 6592 ZN	RONDELLE D12 UNI 6592 ZN	SCHEIBE D12 UNI 6592 ZN	ARANDELA D12 UNI 6592 ZN
27	F01010292	VITE M12X1,25X45 U5740 8.8 ZG	BOLT M12X1,25X45 U5740 8.8 ZG	VIS M12X1,25X45 U5740 8.8 ZG	SCHRAUBE M12X1,25X45 U5740 8.8	TORNILLO M12X1,25X45 U5740 8.8
28	F01100011	INGRASS. A SFERE M6X1	SPHERE NIPPLE M6X1/A	GRAISSEUR A BILLES M6X1/A	KUGELFETTBSCHSE M6X1/A	ENGRAS. DE ESFERAS M6X1/A
29	R17815760	LAMA SUPPORTO REGOLAZIONE SX	SUPPORT BLADE ADJUSTMENT SX	SUPPORT LAME REGLAGE SX	HALTERUNG MESSER SX	CUCHILLA SOPORTE
30	R17811202	RULLO 40 DENTI 3,0	ROLLER 40 TEETH 3,0	ROULEAU A 40 DENTS 3,0	40 ZAHN ROLLE 3,0	RODILLO DE 40 DIENTES 3,0
31	R17811212	RULLO 36 DENTI 3,0	ROLLER 36 TEETH 3,0	ROULEAU A 36 DENTS 3,0	36 ZAHN ROLLE 3,0	RODILLO DE 36 DIENTES 3,0
32	R17811612	PROTEZIONE 3M	GUARD 3M	PROTECTION 3M	SCHUTZ 3M	PROTECCION 3M
33	R17812111	RULLO 4,0 52 DENTI L=3912	ROLLER 4,0 52 TEETH L=3912	ROULEAU 4,0 52 DENTS L=3912	ROLLE 4,0 52 ZAHN L=3912	RODILLO 4,0 52 DIENTES L=3912
34	R17812121	RULLO 4,0 48 DENTI L=3912	ROLLER 4,0 48 TEETH L=3912	ROULEAU 4,0 48 DENTS L=3912	ROLLE 4,0 48 ZAHN L=3912	RODILLO 4,0 48 DIENTES L=3912
35	R17812091	PROTEZIONE 4 M	GUARD 4 M	PROTECTION 4 M	SCHUTZ 4 M	PROTECIEN 4 M
36	R17813280	RULLO 5,0 64 DENTI L=4932	ROLLER 5,0 64 TEETH L=4932	ROULEAU 5,0 64 DENTS L=4932	ROLLE 5,0 64 ZAHN L=4932	RODILLO 5,0 64 DIENTES L=4932
37	R17813290	RULLO 5,0 60 DENTI L=4932	ROLLER 5,0 60 TEETH L=4932	ROULEAU 5,0 60 DENTS L=4932	ROLLE 5,0 60 ZAHN L=4932	RODILLO 5,0 60 DIENTES L=4932
38	R17813270	TUBO DI PROTEZIONE 5M	PIPE 5M	TUBE 5M	ROHR 5M	TUBO 5M
39	M38100992	FLANGIA PORTA CUSCINETTI	BEARING HOLDER FLANGE	BRIDE PORTE ROULEMENTS	LAGERHALTERUNGSFLANSCH	BRIDA PORTA COJINETES
40	F02050168	ANELLO E. DE 40X1,75 U7435 C70	SEEGER RING D.40	BAGUE SEEGER D.40	SEEGERRING D.40	ANILLO SEEGER D.40
41	M48000307	ANELLO RINF.40X50X1,5 C70 TEMP	SEEGER STIFFENER RING	ANNEAU DE RENFORCEMENT SEEGER	SEEGER RING	ANILLO REFUERZO SEEGER
42	F04010184	CUSC.DE SFERICO 76208 A2KS FAG	BEARING 6208 SEE	ROULEMENT 6208 SEE	LAGER 6208 SEE	COJINETE 6208 SEE
43	M38100990	GUARNIZIONE ELASTICA	GASKET	JOINT	DICHTUNG	JUNTA
44	M38100991	MOZZO RULLO OSCILLANTE FINITO	SWINGING ROLLER HUB	EMBAYAGE	KUPPLUNG	FRICCION

TAV. 050

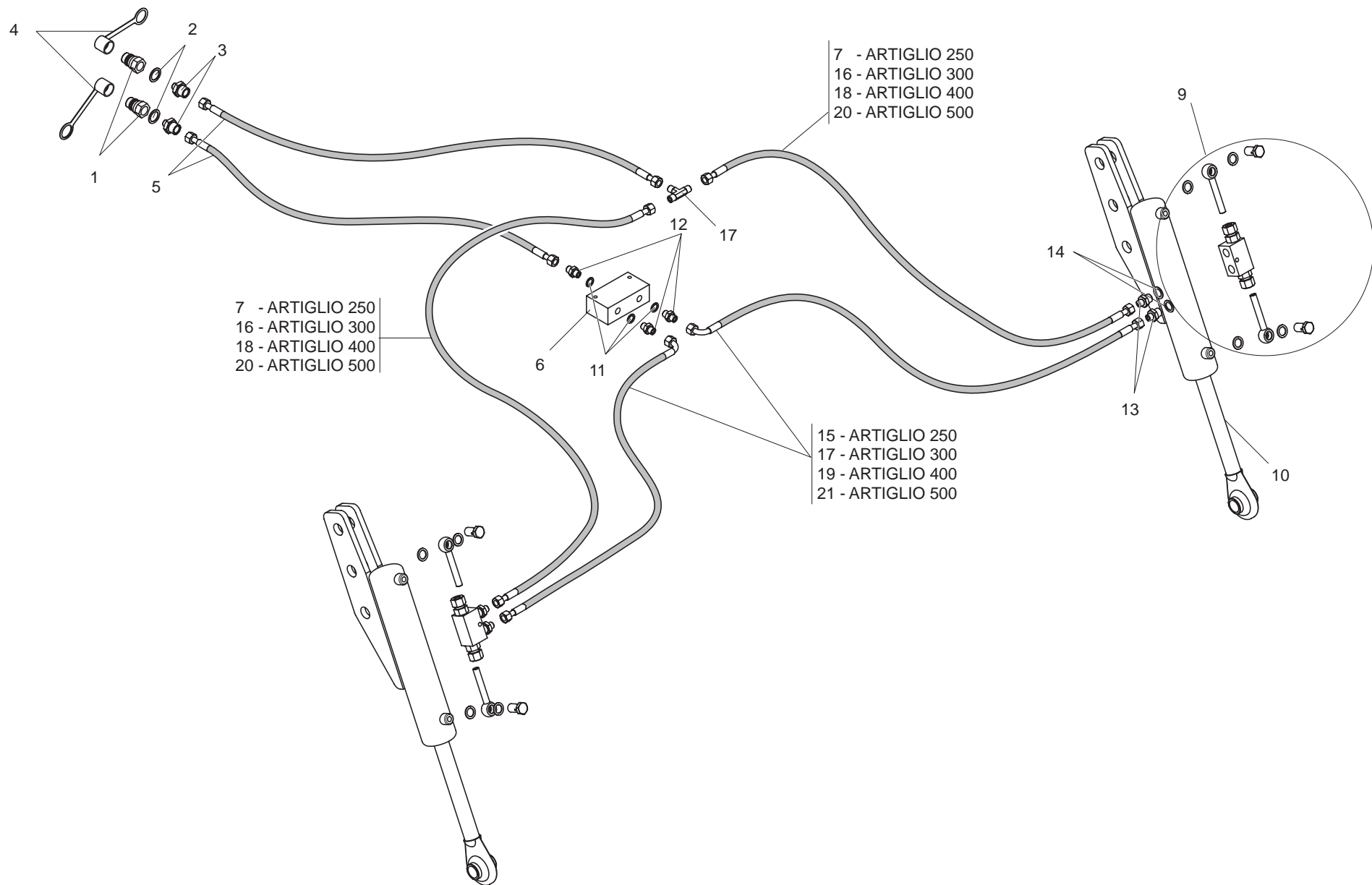

# IMPIANTO OLEODINAMICO

TAV. 050

Pos.	Cod.	Descrizione	Description	Description	Benennung	Description
1	F03150935	INNESTO RAPIDO MASCH.CONO 1/2	QUICK CONNECT MALE CONE 1/2 CO	CONNEXION RAPIDE MALE CONE 1/2	SCHNELLKUPPLUNG GEWINDE KONISC	ACOPLAMIENTO RAPIDO MACHO CONO
2	F03151237	RONDELLA RAME 21X27X1,5 -1/2"	1/2 COPPER WASHER	RONDELLE CUIVRE 1/2	UNTERLEGSCHEIBE KUPFER 1/2	ARANDELA COBRE 1/2
3	F03150211	NIPPLO MASCH.CIL.1/2-1/4 ZN	NIPPLE 1/4-1/2	NIPLE 1/4-1/2	NIPLE 1/4-1/2	NIPLE 1/4-1/2
4	F05150325	CAPPUCCIO INNESTO 1/2	COVER 1/2	COUVERCLE 1/2	DECKEL 1/2	TAPA 1/2
5	G23440517	TUBO 1/4R2 C-F 1/4 L2000 HL/ID	PIPE 1/4R2 C-F 1/4 L2000 HL/ID	TUBE 1/4R2 C-F 1/4 L2000 HL/ID	ROHR 1/4R2 C-F 1/4 L2000 HL/ID	TUBO 1/4R2 C-F 1/4 L2000 HL/ID
6	F03151259	VALVOLA DIVISORE DI FLUSSO	VALVE FLOW DIVIDERS	VALVE DIVISEUR DE DEBIT	OLSTROMVERTEILER EINFACHWIRKEN	VALVULA DIVISOR CON TARA FIJA
7	G17915100	TUBO 1/4 F-F L.2800	PIPE 1/4 F-F L.2800	TUBE 1/4 F-F L.2800	ROHR 1/4 F-F L.2800	TUBO 1/4 F-F L.2800
8	F03151219	RACCORDO -T- MASCHIO 1/4 ZINC.	MALE T-UNION 1/4 ZINC.	RACCORD -T- MALE 1/4 ZING.	ANSCHLUSSTsCK -T- GEWINDE 1/4	UNIN -T- MACHO 1/4 CINC. R
9	F03151158	KIT VALVOLA BLOCCO 3/8 7014200	KIT CHECK VALVES 3/8 7014200	KIT CLAPET DE BLOCAGE 3/8	KIT RUCKSCHLAGVENTIL 3/8	KIT VALVULAANTIRATORNO
10	R17811481	CILINDRO 30X70 - 280	CYLINDER 30X70 - 280	CYLINDRE 30X70 - 280	ZYLINDER 30X70 - 280	CILINDRO 30X70 - 280
11	F03151238	RONDELLA RAME 13X19X1,5 -1/4"	1/4 COPPER WASHER	RONDELLE CUIVRE 1/4	UNTERLEGSCHEIBE KUPFER 1/4	ARANDELA COBRE 1/4
12	F03150266	NIPLU TATA CIL.1/4 ZN	NIPPLE GALV.CYL.MALE 1/4 ZN	NIPPLE MALE CYL. 1/4 ZN	NIPPELZYL.1/4 ZN	NIPLE MACHO CIL.1/4 ZN
13	F03150310	NIPPLO MASCH.CIL.3/8-1/4 ZN	NIPPLE GALV.CYL.MALE3/8-1/4 ZN	NIPPLE MALE CYL.3/8-1/4 ZN	NIPPELZYL.3/8-1/4 ZN	NIPLE MACHO CIL.3/8-1/4 ZN
14	F03151240	RONDELLA RAME 3/8	3/8 COPPER WASHER	RONDELLE CUIVRE 3/8	UNTERLEGSCHEIBE KUPFER 3/8	ARANDELA COBRE 3/8
15	G15210551	TUBO 1/4R2 C-F L.2750 LM	PIPE 1/4R1 C-F L.2750 LM	TUBE 1/4R1 C-F L. 2750 LM	ROHR 1/4R1 C-F L.2750 LM	TUBO 1/4R1 C-F L.2750 LM
16	R17814480	TUBO 1/4R2 F1/4- F1/4 L=3000	PIPE 1/4R2 F1/4- F1/4 L=3000	TUBE 1/4R2 F1/4- F1/4 L=3000	ROHR 1/4R2 F1/4- F1/4 L=3000	TUBO 1/4R2 F1/4- F1/4 L=3000
17	G15210631	TUBO 1/4R2 C-F L.3000 LM	PIPE 1/4R2 C-F L.3000 LM	TUBE 1/4R2 C-F L. 3000 LM	ROHR 1/4R2 C-F L.3000 LM	TUBO 1/4R2 C-F L.3000 LM
18	R17814490	TUBO 1/4 R2 F-F 1/4 L.3150	PIPE 1/4 R2 F-F 1/4 L.3150	TUBE 1/4 R2 F-F 1/4 L.3150	ROHR 1/4 R2 F-F 1/4 L.3150	TUBO 1/4 R2 F-F 1/4 L.3150
19	G15210950	TUBO 1/4 R2 C-F 1/4 L.3150	PIPE 1/4-R2 C-F 1/4 M.3150	TUBE 1/4-R2 C-F 1/4 M.3150	ROHR 1/4-R2 C-F 1/4 M.3150	TUBO 1/4-R2 C-F 1/4 M.3150
20	G10411711	TUBO 1/4R2 F-F 1/4 L.3600 LM	PIPE 1/4R2 F-F 1/4 L.3600 LM	TUBE 1/4R2 F-F 1/4 L.3600 LM	ROHR1/4R2 F-F 1/4 L.3600 LM	TUBO 1/4R2 F-F 1/4 L.3600 LM
21	G15210561	TUBO 1/4R2 C-F 1/4 L.3500 LM	PIPE 1/4R2 C-F 1/4 L.3500 LM	TUBE 1/4R2 C-F 1/4 L. 3500 LM	ROHR 1/4R2 C-F 1/4 L.3500 LM	TUBO 1/4R2 C-F 1/4 L.3500 LM

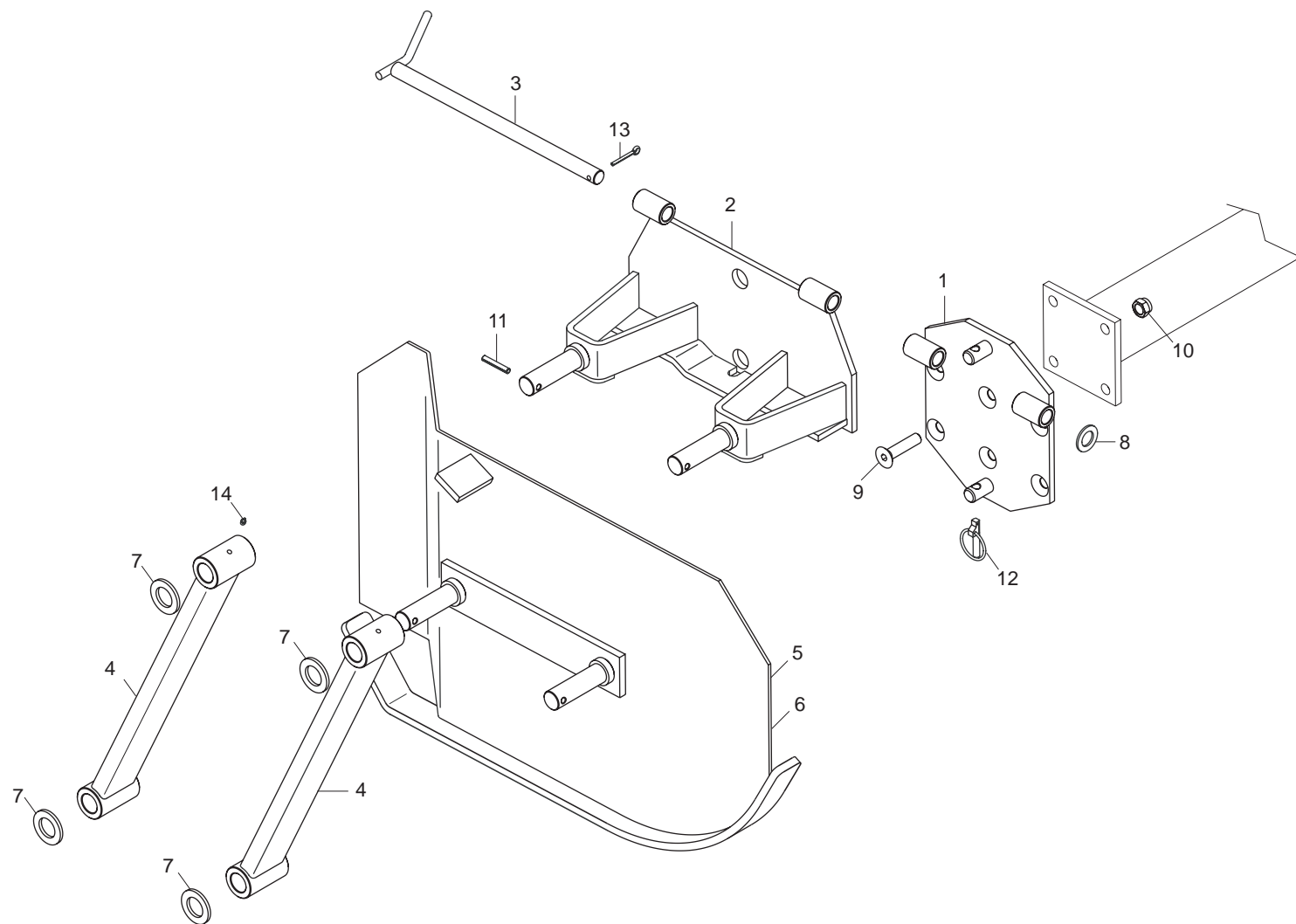

**BANDINELLE LATERALI**

TAV. 060

Pos.	Cod.	Descrizione	Description	Description	Benennung	Descripcion
1	R17811650	PIASTRA DI ATTACCO	FIXING PLATE	PLAQUE DE RACCORD	KUPPLUNGSPLATTE	PLACA DE CONEXIN
2	R17811710	RIBALTAMENTO BANDELLE	SUPPORT	SUPPORT	HALTERUNG	SOPORTE
3	R17811730	PERNO ZN	PIN ZN	PIVOT ZN	BOLZEN ZN	PERNO ZN
4	R17811760	LEVA	LEVER	LEVIER	HEBEL	PALANCA
5	R17811821	BANDELLA SX	PROTECTION SX	PROTECTION SX	SCHUTZ SX	PROTECCION SX
6	R17811831	BANDELLA DX	PROTECTION DX	PROTECTION DX	SCHUTZ DX	PROTECCION DX
7	G20970067	RONDELLA 54X5X32	WASHER 54X5X32	RONDELLE 54X5X32	UNTERLEGSCHIEBE 54X5X32	ARANDELA 54X5X32
8	F01410135	RONDELLA D22 UNI 6592 ZN	PLANE WASHER D.22	BAGUE D.22	SCHIEBE D.22	ARANDELA D.22
9	F01030152	VITE M16X 2X70 U5933 8.8 ZG	BOLT 16X70 5933 8.8 GALVANIZED	VIS 16X70 5933 8.8 ZN	SCHRAUBE 16X70 5933 8.8 ZN	TORNILLO 16X70 5933 8.8 ZN
10	F01230085	DADO M16X 2 D982 8 ZG	SELF LOCKING NUT M16X2 D982 6S	ECROU AUTOBL. M16X2 D982 6S	SELBSTSPERR.MUTTER M16X2 D982	DADO AUTOBL. M16X2 D982 6S
11	F02100144	SPINA EL.8X50 DIN 1481	ELASTIC PIN 8X50	GOUJON ELASTIQUE 8X50	SPANNHUELSE 8X50	ESPINA ELASTICA 8X50
12	F02200507	SPINA A SCATTO D 9 B/83	SNAP PIN D 9 B/83	FICHE A DETENTE D 9 B/83	EINRASTSTIFT D 9 B/83	CLAVIJA DE MUELLE D 9 B/83
13	F02200229	COPIGLIA 5 X45 1336 ZN	SPLIT PIN 5 X45 1336 GALVAN.	GOUPILLE 5 X45 1336 ZN	SPLINT 5 X45 1336 ZN	PASADOR 5 X45 1336 ZN
14	F01100048	ING.M 8X1,25 7663A 9SMNPB28 ZG	SPHERE NIPPLE M8X 1,25 A	GRAISSEUR A BILLES M8 X 1-25 A	KUGELFETTBSCHSE M8 X 1-25 A	ENGRAS. DE ESFERAS M8 X 1-25 A

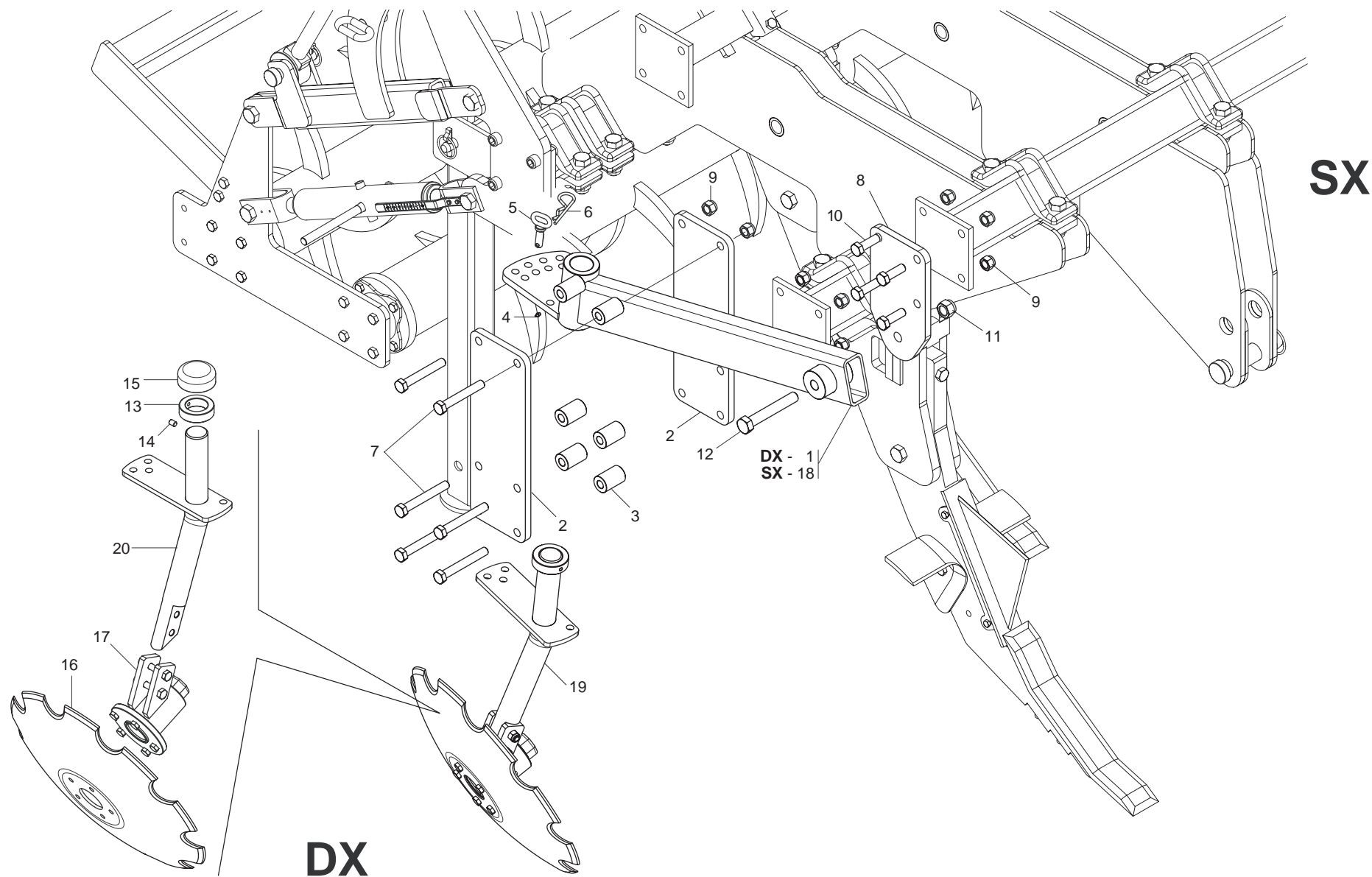



# DISCHI DI CONTENIMENTO

TAV. 070

Pos.	Cod.	Descrizione	Description	Description	Benennung	Descripcion
1	R17810900	SUPPORTO DISCO DX	DISC SUPPORT DX	SUPPORT DISQUE DX	SCHEIBENHALTERUNG DX	SOPORTE DISCO DX
2	R17810820	LAMA REGOLAZIONE FINECORSA	TRAVEL STOP BRACKET	BRIDE FIN DE COURSE	BsGEL ENDANSCHLAG	ESTR. FINAL DE CARRERA
3	R17810880	BOCCOLA 16,5 X35 X52 ZN	BUSHING 16,5 X35 X52 ZN	BOITE 16,5 X35 X52 ZN	BsCHSE 16,5 X35 X52 ZN	CASQUILLO 16,5 X35 X52 ZN
4	F01100011	UNGATOR CU SFERA FORMA A M6X1	SPHERE NIPPLE M6X1/A	GRAISSEUR A BILLES M6X1/A	KUGELFETTBSCHSE M6X1/A	ENGRAS. DE ESFERAS M6X1/A
5	R17810970	SPINA ZN	PIN ZN	GOUPILLE ZN	BOLZENSTIFT ZN	PASADOR ZN
6	F02200397	COPIGLIA R 5X100 ZN	SPLIT PIN R 5X100 GALVANIZED	GOUPILLE R 5X100 ZN	SPLINT R 5X100 ZN	PASADOR R 5X100 ZN
7	F01020266	VITE 16X120 5737 8.8 ZN	BOLT 16X120 5737 8.8 GALVANIZ	VIS 16X120 5737 8.8 ZN	SCHRAUBE 16X120 5737 8.8 ZN	TORNILLO 16X120 5737 8.8 ZN
8	R17810810	LAMA AGGANCIAMENTO TUBO	TUBE COUPLER	ATTELAGE TUBE	KUPPLUNG ROHR	ENGANCHE TUBO
9	F01230085	DADO M16X 2 D982 8 ZG	SELF LOCKING NUT M16X2 D982 6S	ECROU AUTOBL. M16X2 D982 6S	SELBSTSPERR.MUTTER M16X2 D982	DADO AUTOBL. M16X2 D982 6S
10	F01020252	VITE M16X 2X 50 U5737 8 8 ZG	BOLT M 16X 2 X50	VIS M 16X 2 X 50	SCHRAUBE M 16X 2 X50	TORNILLO M 16X 2 X50
11	F01230131	DADO M20X 2,5 D982 6 ZG	SELF LOCKING NUT M20X2,5	ECROU AUTOBL. M20X2,5	MUTTER M20X2,5	DADO AUTOBL. M20X2,5
12	F01020316	VITE M20X2,5X130 U5737 8.8 ZG	SCREW 20X130 5737 8.8 GALVAN.	VIS 20X130 5737 8.8 ZN	SCHRAUBE 20X130 5737 8.8 ZN	TORNILLO 20X130 5737 8.8 ZN
13	G67002048	BOCCOLA DI BLOCCO	BLOCK BUSHING	BOITE DE ENSEMBLE	BLOCKBSCHSE	CASQUILLO DE BLOQUE
14	G67002049	GRANO	GRUB--SCREW	GOUJON	STIFT	TORNILLO SIN CABEZA
15	G67002047	TAPPO	CLOSURE TAP	BOUCHON DE FERMETURE	ABSCHLUSSPFROPFEN	TAPN DE CIERRE
16	G67002046	DISCO DENTATO	TOOTHED DISK	DISQUE DENTE	VERZAHNTE SCHEIBE	DISCO DENTADO
17	G67002045	SUPPORTO CUSCINETTI	BEARING SUPPORT	SUPPORT PALIER	LAGERB_CHSE	SOPORTE COJINETE
18	R17810940	SUPPORTO DISCO SX	DISC SUPPORT SX	SUPPORT DISQUE SX	SCHEIBENHALTERUNG SX	SOPORTE DISCO SX
19	R17811090	BRACCIO SUPPORTO DISCO DX	DISC ARM SUPPORT DX	SUPPORT BRAS DISQUE DX	HALTERUNG SCHEIBENARM DX	SOPORTE BRAZO DISCO DX
20	R17811080	BRACCIO SUPPORTO DISCO SX	DISC ARM SUPPORT	SUPPORT BRAS DISQUE	HALTERUNG SCHEIBENARM	SOPORTE BRAZO DISCO

TAV. 080

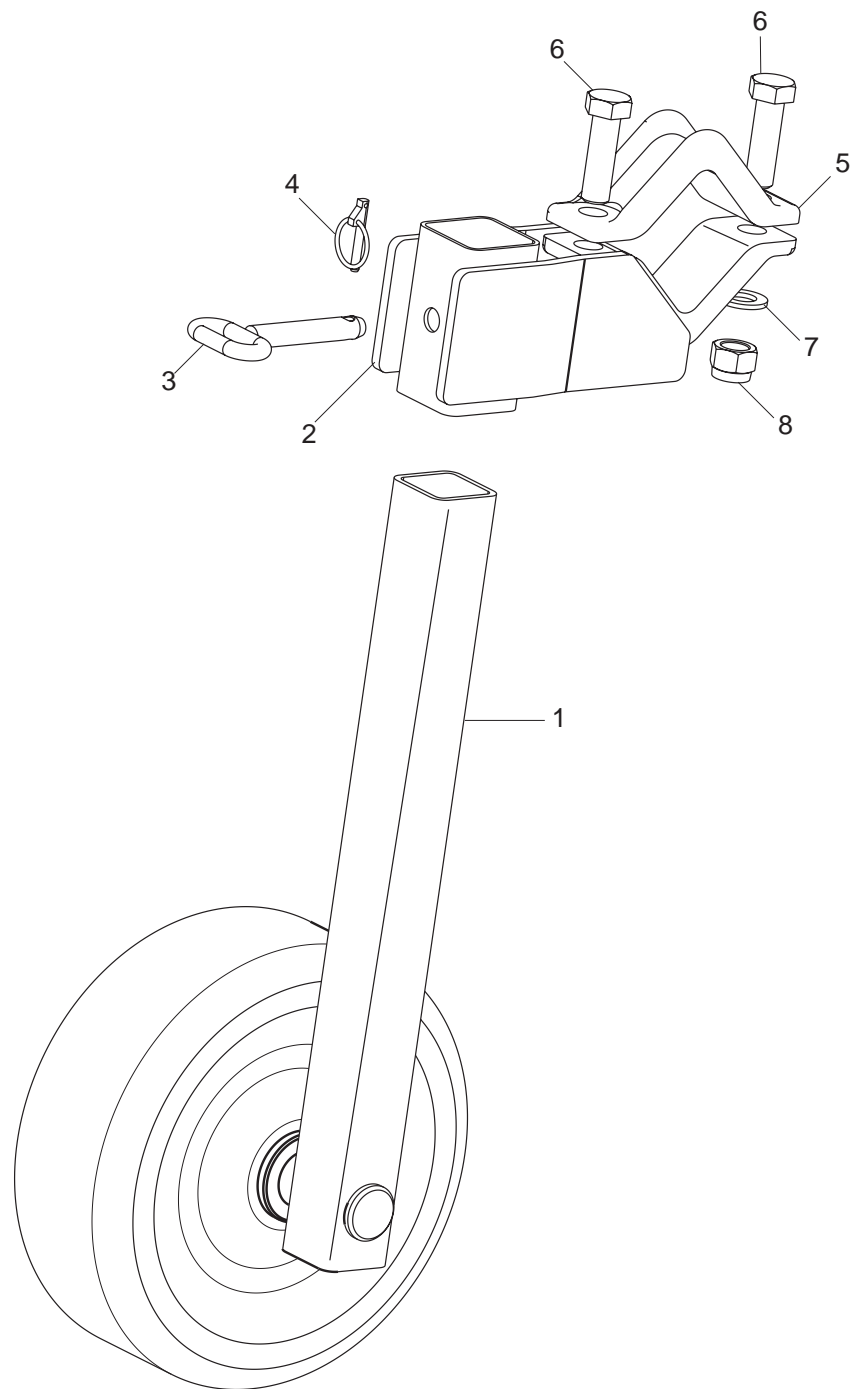

# RUOTA DI SOSTEGNO

TAV. 080

Pos.	Cod.	Descrizione	Description	Description	Benennung	Descripcion
1	R18012160	RUOTA	WHEEL	ROUE	TIEFEN	RUEDA
2	R17815720	SUPPORTO SOSTEGNO	SUPPORT SEALING	SUPPORT ETANCHEITE	HALTERUNG DICHTUNGS	SOPORTE AISLADOR
3	R17810440	PERNO ZN	PIN ZN	PIVOT ZN	BOLZEN ZN	PERNO ZN
4	F02200507	SPINA A SCATTO D 9 B/83	SNAP PIN D 9 B/83	FICHE A DETENTE D 9 B/83	EINRASTSTIFT D 9 B/83	CLAVIJA DE MUELLE D 9 B/83
5	R17811170	SCONTRO PER TUBO 100	STRIKER PLATE 100	BUTEE 100	ANSCHLAG 100	ELEMENTO DE EMPALME 100
6	F01020343	VITE M24X 3X 80 U5737 10.9 ZG	BOLT 24X80 5737 10.9G GALVANI	VIS 24X80 5737 10.9G ZN	SCHRAUBE 24X80 5737 10.9G ZN	TORNILLO 24X80 5737 10.9G ZN
7	G18701590	RONDELLA 25X35X2,5 ZN	WASHER 25 x 35 x2,5 ZN	RONDELLE 25 x 35 x2,5 ZN	UNTERLEGSCHEIBE 25 x 35 x2,5 Z	ARANDELA 25 x 35 x2,5 ZN
8	F01230144	DADO AUTOB.NORM.24 ZN	SELF-LOCKING NUT NORM.24 ZN	ECROU AUTOB.NORM.24 ZN	SELBSTSPERR. MUTTER NORM.24 ZN	TUERCA AUTOB .NORM.24 ZN

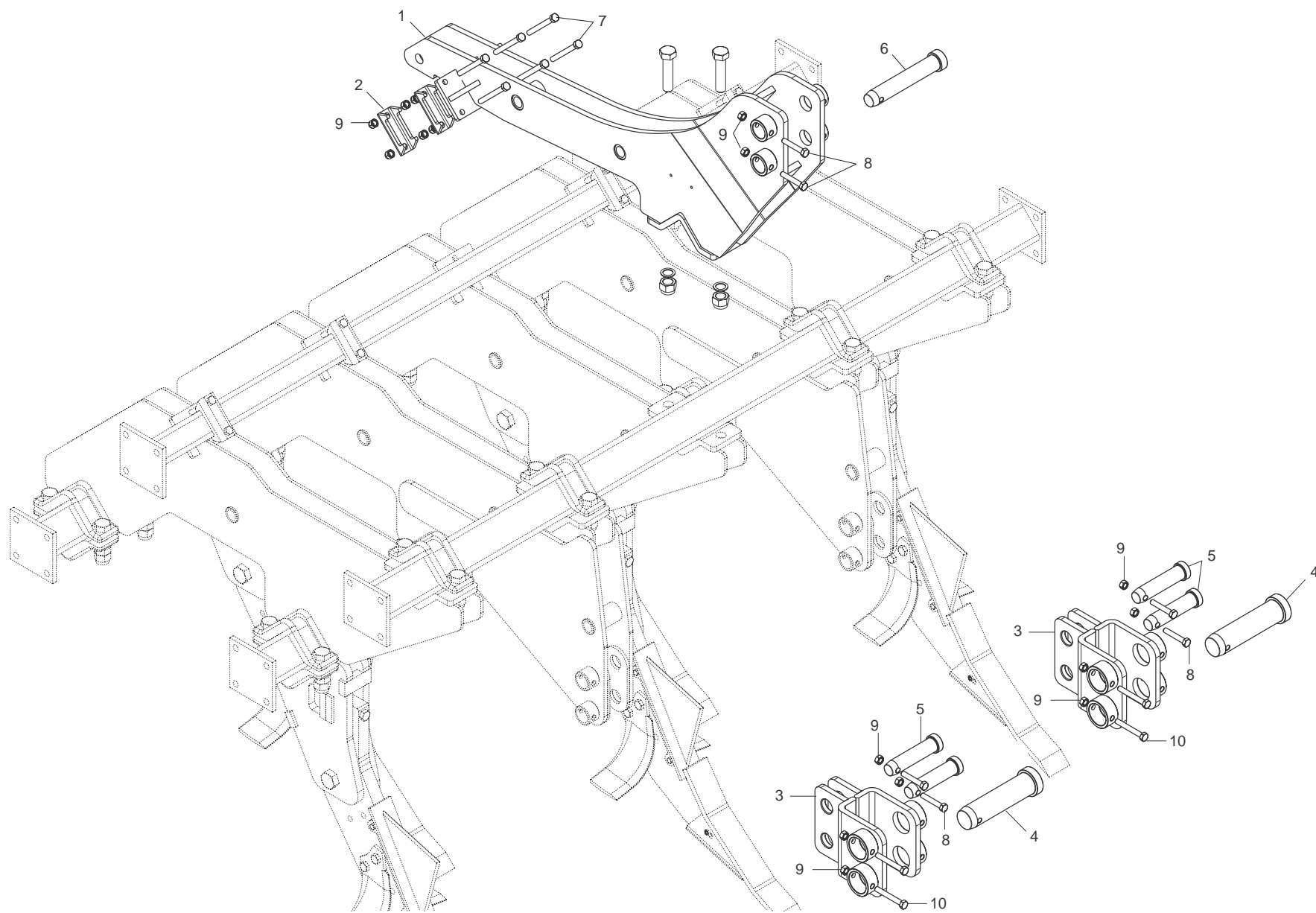

**ATTACCO "IV" CATEGORIA**

**TAV. 090**

Pos.	Cod.	Descrizione	Description	Description	Benennung	Descripcion
1	R17812460	TERZO PUNTO 4 CAT.	ATTACHMENT	FIXATION	ANSCHLUSS	CONEXIN
2	G16740160	SCONTRO A U SP.8 2F13 83	U-SHAPED STOP TEETH B343SP.8	BUTEE EN U SP.8 2F13 83	U-ANSCHLAG SP.8 2F13 83	DIENTE DE PARADA A U ESP.8
3	R17812380	ATTACCO 1-2 PUNTO	1-2 POINT COUPLING	FIXATION 1-2 POINT	KUPPLUNG 1-2 PUNKT	CONEXIN 1-2 PUNTO
4	R17812390	SPINA GASPARDO 56X190 ZG	GASPARDO PIN 56X190 ZG	BROCHE GASPARDO 56X190 ZG	STIFT GASPARDO 56X190 ZG	CLAVIJA GASPARDO 56X190 ZG
5	F20100112	STIFT GASPARDO 36X134 ZG	GASPARDO PIN 36X134 ZG	BROCHE GASPARDO 36X134 ZG	STIFT GASPARDO 36X134 ZG	CLAVIJA GASPARDO 36X134 ZG
6	R17812440	SPINA GASPARDO 39X200 ZG	GASPARDO PIN 39X200 ZG	BROCHE GASPARDO 39X200 ZG	STIFT GASPARDO 39X200 ZG	CLAVIJA GASPARDO 39X200 ZG
7	F01020174	VITE 12X120 5737 8.8 ZN	BOLT 12X120 5737 8.8 GALVANIZ.	VIS 12X120 5737 8.8 ZN	SCHRAUBE 12X120 5737 8.8 ZN	TORNILLO 12X120 5737 8.8 ZN
8	F01020164	VITE M12X1,75X70 U5737 8.8 ZG	BOLT 12X70 5737 8.8 GALVANIZED	VIS 12X70 5737 8.8 ZN	SCHRAUBE 12X70 5737 8.8 ZN	TORNILLO 12X70 5737 8.8 ZN
9	F01220244	DADO TRISTOP M12	NUT- TRISTOP M12	ECROU TRISTOP M12	MUTTER TRISTOP M12	TUERCA TRISTOP M12
10	F01020344	VITE M24X 3X100 U5737 10.9 ZG	SCREW 24X100 5737 10.9 ZN	VIS 24X100 5737 10.9 ZN	SCHRAUBE 24X100 5737 10.9 ZN	TORNILLO 24X100 5737 10.9 ZN

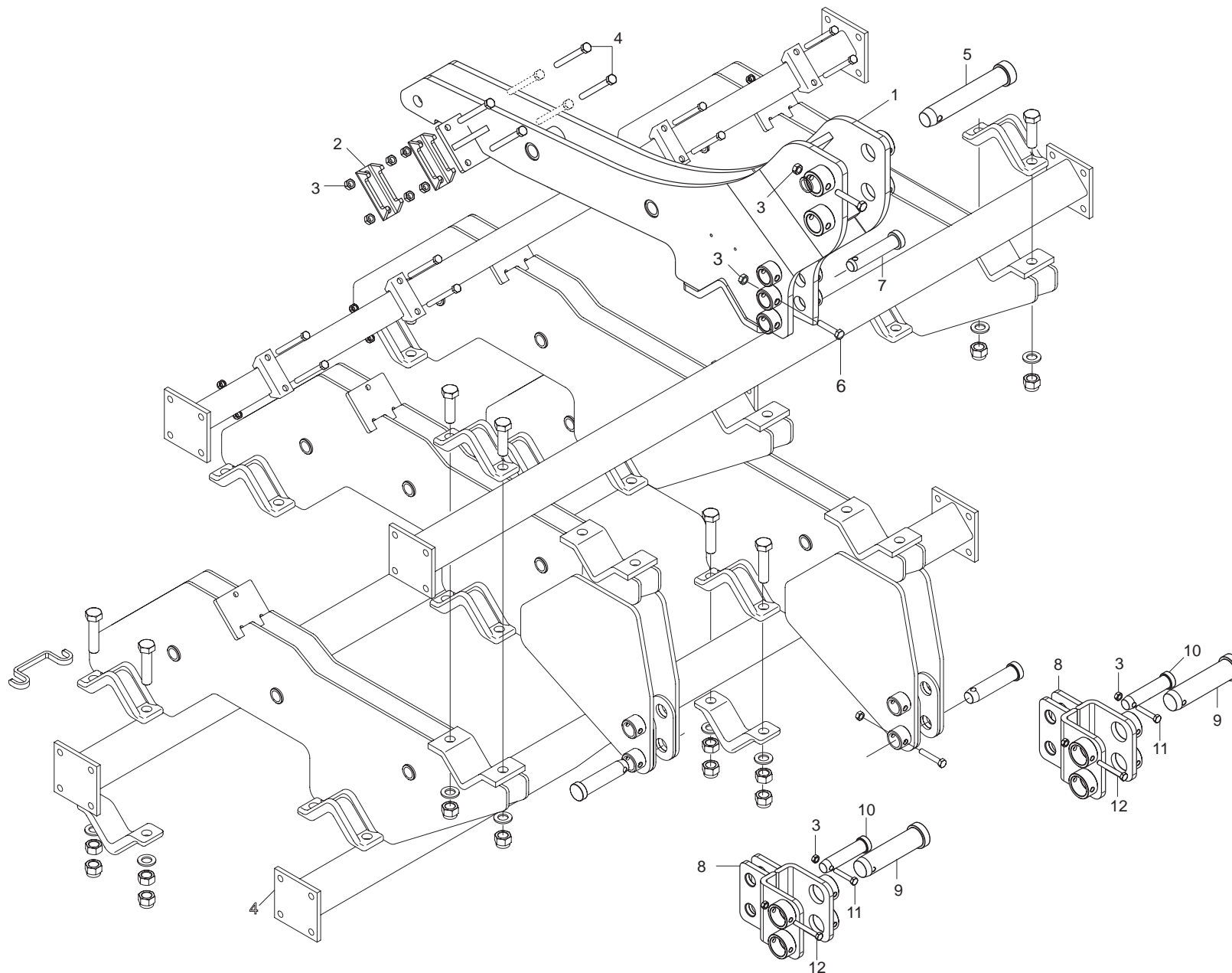

**ATTACCO "III" E "IV" CATEGORIA**

**TAV. 100**

Pos.	Cod.	Descrizione	Description	Description	Benennung	Descripcion
1	R17817480	ASS.ATTACC. 3-4 CATEG.	3-4 POINT LINKAGE FRAME	ATTELAGE UNIVERSEL 3-4 POINTS	3-4 PUNKT ANSCHLUSS HALTERUNG	ENGANCHE DE 3-4 PUNTOS
2	G16740160	SCONTRO A U SP.8 2F13 83	U-SHAPED STOP TEETH B343SP.8	BUTEE EN U SP.8 2F13 83	U-ANSCHLAG SP.8 2F13 83	DIENTE DE PARADA A U ESP.8
3	R17812380	ATTACCO 1-2 PUNTO	1-2 POINT COUPLING	FIXATION 1-2 POINT	KUPPLUNG 1-2 PUNKT	CONEXIN 1-2 PUNTO
4	R17812390	SPINA GASPARDO 56X190 ZG	GASPARDO PIN 56X190 ZG	BROCHE GASPARDO 56X190 ZG	STIFT GASPARDO 56X190 ZG	CLAVIJA GASPARDO 56X190 ZG
5	F20100112	STIFT GASPARDO 36X134 ZG	GASPARDO PIN 36X134 ZG	BROCHE GASPARDO 36X134 ZG	STIFT GASPARDO 36X134 ZG	CLAVIJA GASPARDO 36X134 ZG
6	R17812440	SPINA GASPARDO 39X200 ZG	GASPARDO PIN 39X200 ZG	BROCHE GASPARDO 39X200 ZG	STIFT GASPARDO 39X200 ZG	CLAVIJA GASPARDO 39X200 ZG
7	F01020174	VITE 12X120 5737 8.8 ZN	BOLT 12X120 5737 8.8 GALVANIZ.	VIS 12X120 5737 8.8 ZN	SCHRAUBE 12X120 5737 8.8 ZN	TORNILLO 12X120 5737 8.8 ZN
8	F01020164	VITE M12X1,75X70 U5737 8.8 ZG	BOLT 12X70 5737 8.8 GALVANIZED	VIS 12X70 5737 8.8 ZN	SCHRAUBE 12X70 5737 8.8 ZN	TORNILLO 12X70 5737 8.8 ZN
9	F01220244	DADO TRISTOP M12	NUT- TRISTOP M12	ECROU TRISTOP M12	MUTTER TRISTOP M12	TUERCA TRISTOP M12
10	F01020168	VITE 12X90 5737 8.G ZN	BOLT 12X90 5737 8.G GALVANIZED	VIS 12X90 5737 8.G ZN	SCHRAUBE 12X90 5737 8.G ZN	TORNILLO 12X90 5737 8.G ZN

**USATE SEMPRE RICAMBI ORIGINALI  
ALWAYS USE ORIGINAL SPARE PARTS  
IMMER DIE ORIGINAL-ERSATZTEILE VERWENDEN  
EMPLOYEZ TOUJOURS LES PIECES DE RECHANGE ORIGINALES  
UTILIZAR SIEMPRE REPUESTOS ORIGINALES**

# **GASPARDO**

DEALER:

# **GASPARDO**



# **RISPARDO**

**\*R19530070\***

**GASPARDO Seminatrici SpA**  
Via Mussons, 7 - I - 33075  
Morsano al Tagliamento (PN) Italy  
Tel. +39 0434 695410  
Fax +39 0434 695425  
e-mail: [gaspardo@gaspardo.it](mailto:gaspardo@gaspardo.it)  
<http://www.gaspardo.it>

**MASCHIO DEUTSCHLAND GMBH**  
Äußere Nürnberger Straße 5  
D - 91177 Thalmässing  
Deutschland  
Tel. +49 (0) 9173 79000  
Fax +49 (0) 9173 790079

**MASCHIO FRANCE Sarl**  
1, Rue de Mérignan ZA  
F - 45240 La Ferte St. Aubin  
France  
Tel. +33 (0) 2.38.64.12.12  
Fax +33 (0) 2.38.64.66.79

**MASCHIO IBERICA S.L.**  
Calle Cabernet, 10  
Poligono Industrial Clot de Moja  
Olerdola - 08734 Barcelona  
Tel. +34 93.81.99.058  
Fax +34 93.81.99.059

**MASCHIO USA**  
432 2<sup>ND</sup> Street  
Rock Island, IL 61201 USA  
Ph. +1 309 794-2310  
Fax +1 309 788-1610

**MASCHIO MIDDLE EAST S.L.**  
**MASCHIO-GASPARDO ROMANIA S.R.L.**  
**GASPARDO-MASCHIO TURCHIA**  
**MASCHIO-GASPARDO CANADA Inc**