

MASCHIO GASPARDO

MASCHIO GASPARDO ROMANIA S.R.L.

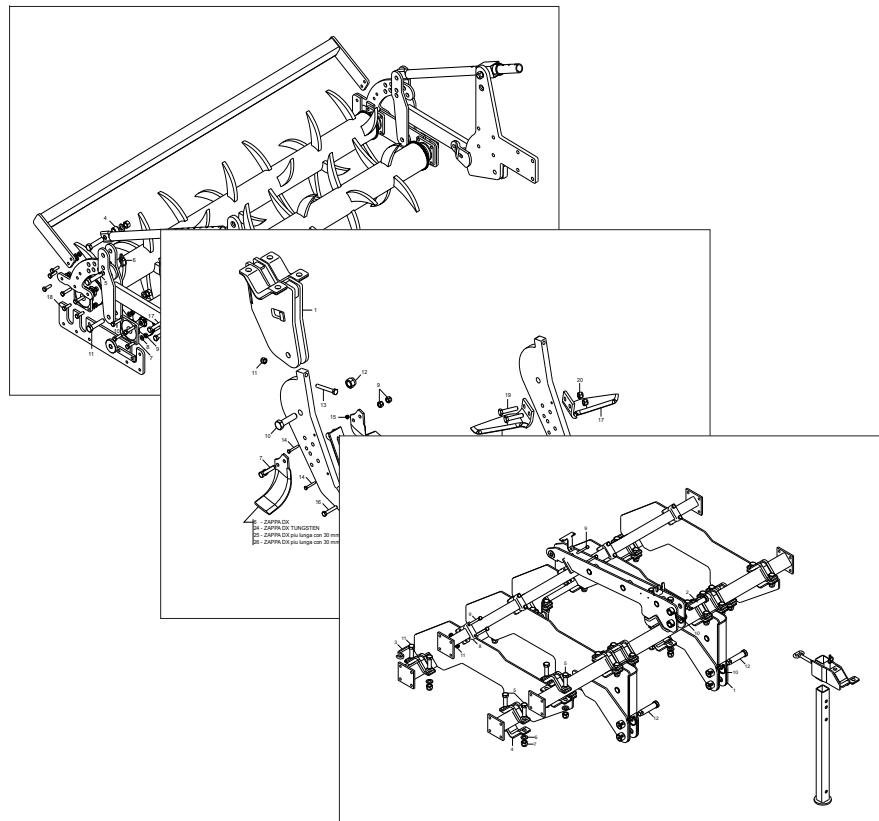

ATTILA

Cod: R19530770 06 / 2008

- *) Valido per Paesi UE
- *) Valid for EU member countries
- *) Gilt für EU-Mitgliedsländer
- *) Valable dans le Pays UE
- *) Válido para Países UE
- *) Valabil pentru țările UE

- IT** PARTI DI RICAMBIO
- EN** SPARE PARTS
- DE** ERSATZTEILE
- FR** PIÈCES DÉTACHÉES
- ES** PIEZAS DE REPUESTO
- RO** PIESE DE SCHIMB

PARTI DI RICAMBIO

Le ordinazioni delle parti di ricambio vanno fatte presso i nostri concessionari di zona e devono essere sempre corredate dalle seguenti indicazioni:

- **Tipo, modello e numero di matricola dell'attrezzatura.** Tali dati sono stampigliati nell'apposita targhetta di cui è dotata ogni attrezzatura.
 - **Numero di codice della parte richiesta** rilevabile dal catalogo ricambi.
 - **Descrizione del particolare e quantità richiesta.**
 - **Numero della tavola.**
 - **Mezzo di trasporto.** Nel caso questa voce non sia specificata, la Ditta Costruttrice, pur dedicando a questo servizio una particolare cura, non risponde di eventuali ritardi di spedizione dovuti a cause di forza maggiore.
- Le spese di trasporto si intendono sempre a carico del destinatario. La merce viaggia a rischio e pericolo del committente anche se venduta franco destino.

NOTA: Il termine **(Dx) Destro** o **(Sx) Sinistro** della macchina o di parti di essa, è inteso guardando la macchina dalla parte posteriore. Le eccezioni saranno indicate.

SPARE PARTS

Orders must be transmitted through our area dealers and should always include the following indications:

- **Type, model and serial number of the machine.** *These data are punched on the data plate with which every implement is equipped.*
- **Code number of the required spare part.** *This will be found in the spare parts catalogue.*
- **Description of the part and required quantity.**
- **Table number.**
- **Means of dispatch.** *If this item is not indicated, the Manufacturer, while dedicating particular care to this service, shall not be held responsible for delays in delivery caused by cases of force majeure.*

Transport expenses shall always be at the consignee's charge. The goods travel at the purchaser's risk and peril even when sold ex destination.

NOTE: *The symbols (Dx) right and (Sx) left, concerning the machine or single parts of it, are referred, as in the figure, to a rear view of them. Exceptions will be indicated.*

ERSATZTEILE

Die Bestellungen müssen bei unseren Gebietshändler aufgegeben werden. Bei der Bestellung sind stets die folgenden Angaben zu machen:

- **Typ, Modell und Serien-Nummer des Geräts.** Diese Daten stehen auf dem Typenschild, mit dem jedes Gerät versehen ist.
- **Artikel Nr. der erforderlichen Ersatzteile.** Diese stehen im Ersatzteil-Katalog.
- **Beschreibung des Ersatzteils und die erforderliche Stückzahl.**
- **Tafelnummer.**
- **Versandmittel.** Wenn dieser Punkt nicht spezifiziert wird, haftet die Herstellerfirma nicht für etwaigen Lieferverzug aufgrund höherer Gewalt, auch wenn er diesen Service besonders aufmerksam abwickelt.

Die Frachtkosten gehen dagegen immer zu Lasten des Empfängers. Die Ware reist auf Gefahr und Risiko des Auftraggebers, auch wenn frei Haus Verkauft vereinbart worden ist.

N.B.: Die Merkzeichen **(Dx) rechts** und **(Sx) links** betreffen eine rückwärtige Aussicht der Maschine oder Teile von ihr (siehe Bild). Ausnahmen werden gezeigt.

PIECES DÉTACHÉES

Les ordres doivent être effectués auprès de nos concessionnaires de zone en précisant les indications suivantes:

- **Type, modèle et numéro de série de la machine.** *Ces données sont gravées sur la plaque d'identification de chaque outil.*
- **Numéro de code de la pièce détachée** *indiqué sur le catalogue des pièces détachées.*
- **Description de la pièce et quantité requise.**
- **Numéro de plan.**
- **Moyen d'expédition.** *Si cette rubrique n'est pas indiquée, le Constructeur, bien que soucieux de ce service, ne répond pas des retards d'expédition pour des causes de force majeure.*

Les frais de transport sont toujours à la charge du destinataire. La marchandise voyage aux risques et périls de l'acheteur même si vendue franco de port.

N.B.: *Les références (Dx) droit et (Sx) gauche de la machine ou des parties de la même, est entendue, comme de la figure, en regardant la machine de derriere dans le sens de marche.*

RESPUESTOS

Los pedidos han de efectuarse en nuestros concesionarios de zona y deben incluir siempre las siguientes indicaciones:

- **Tipo, modelo y número de matrícula del equipo.** Dichos datos están impresos en la relativa placa presente en el equipo.
- **Número de código de la parte requerida** presente en el catálogo respuestas.
- **Descripción de la pieza y cantidad requerida.**
- **Numero de ilustración.**
- **Medio de transporte.** En caso que este ítem no esté especificado, el Fabricante, aún prestando la debidas consideraciones para este aspecto, no responde por eventuales retardos de env'o debidos a causas de fuerza mayor.

Los gastos de transporte se consideran siempre a cargo del destinatario. La mercadería viaja bajo riesgo y peligro del comprador, incluso cuando se vende franco destino.

N.B.: La referencia **(Dx) derecha** o **(Sx) izquierda** de la máquina o de sus componentes, se entiende, como en la figura, mirando la máquina por la parte trasera. Se indicarán las excepciones.

PIESE DE SCHIMB

Comandarea pieselor de schimb se va face prin intermediul concesionarilor din zonă și trebuie să fie întotdeauna însoțite de următoarele date:

- **Tipul, modelul și numărul de matricolă al utilajului.** *Aceste date se găsesc pe plăcuța de identificare a fiecărui utilaj.*
- **Numărul de cod al piesei de schimb cerute,** *care se găsește în manual.*
- **Descrierea piesei de schimb și cantitatea cerută.**
- **Numărul desenului în care se găsește piesa.**
- **Mijloc de transport.** *În cazul în care acesta nu este specificat, Firma Constructoare poate avea un regim special, nu răspunde de eventualele întârzieri de expediere datorate unor cauze de forță majoră.*

Cheltuielile de transport sunt suportate de destinatar. Marfa este transportată pe riscul celui care efectuează comanda, chiar dacă marfa este vândută în condiții franco-destinare.

NOTA: *Termenul (Dx) Dreapta sau (Sx) Stânga a utilajului sau a părților acestuia, este privind utilajul din partea posterioară. Excepțiile vor fi indicate.*

<i>Nr. Tav.</i>	<i>Descrizione - Description</i>	<i>Pag.</i>
TAV. 010	Telaio	4
TAV. 020	Elemento operatore	6
TAV. 030	Doppio rullo posteriore MECCANICO	8
TAV. 040	Doppio rullo posteriore OLEODINAMICO	10
TAV. 050	Impianto oleodinamico rulli posteriori	12
TAV. 060	Dischi posteriori	14
TAV. 070	Ruote di sostegno	16
TAV. 080	Bandinella laterale meccanica e idraulica	18
TAV. 090	Kit "III" e "IV" categoria mod. 2007 - 2008	20
TAV. 100	Kit luci	22

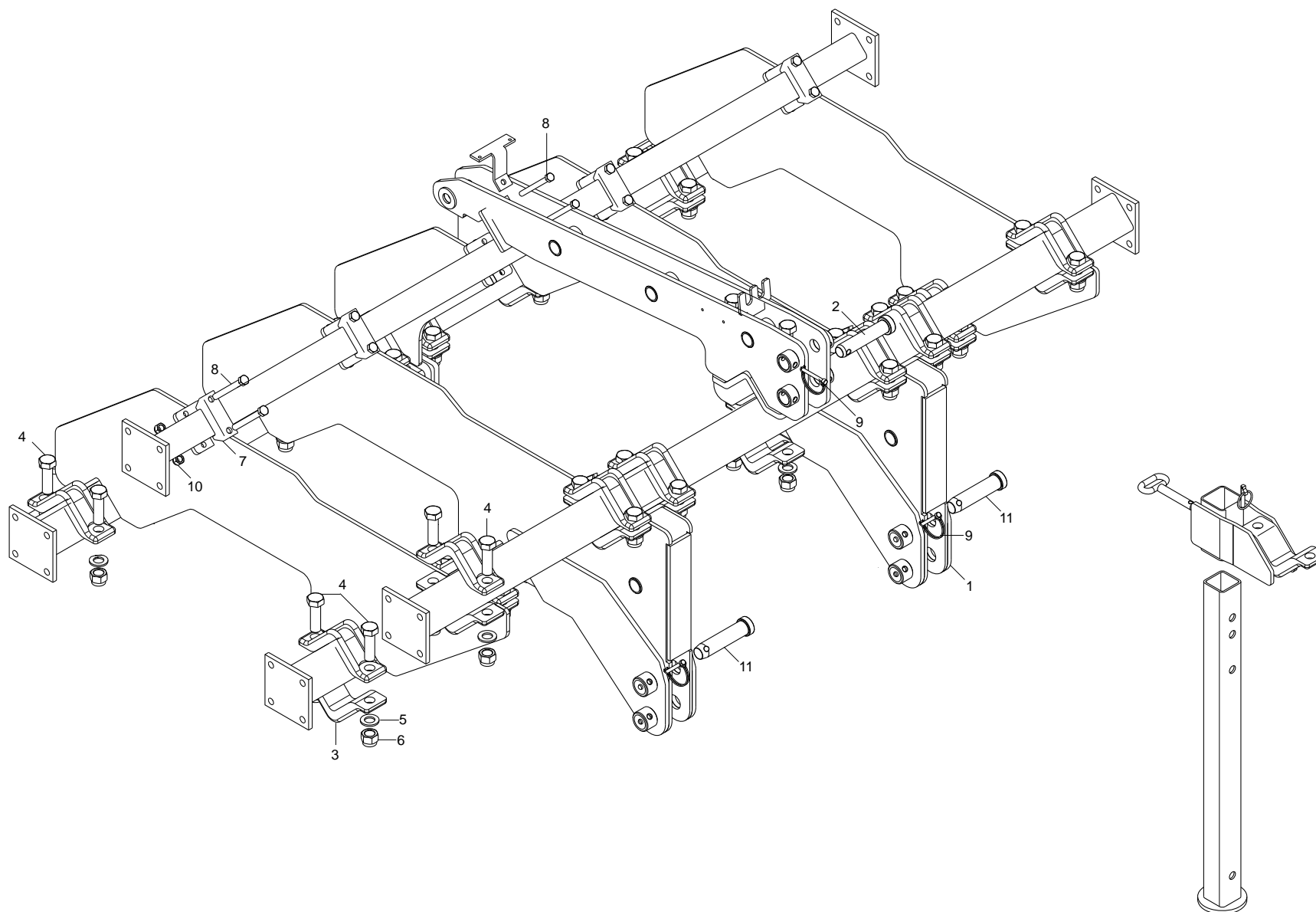

TELAIO

TAV. 010

Pos.	Cod.	Descrizione	Description	Description	Benennung	Descripcion	Descriere
1	R17813741	ASSIEME CENTRALE	FRAME SUPPORT CENTRAL	SUPPORT CH-SSIS	RAHMENHALTERUNG	SOPORTE BASTIDOR	ANSAMBLU CENTRAL
2	F20100101	PERNO D32 L128 C43 ZN	PIN GASPARDO 32X134 ZN	BROCHE GASPARDO 32X134 ZN	STIFT GASPARDO 32X134 ZN	CLAVIJA GASPARDO 32X134 ZN	STIFT GASPARDO 32X134 ZN
3	R17811170	SCONTRIO PER TUBO 100	STRIKER PLATE 100	BUTEE 100	ANSCHLAG 100	ELEMENTO DE EMPALME 100	BRIDA FIXARE TEAVA 100
4	F01020343	VITE M24X 3X 80 U5737 10.9 ZD	BOLT M24X 3X 80 U5737 10.9 ZB	VIS M24X 3X 80 U5737 10.9 ZB	SCHR.M24X 3X 80 U5737 10.9 ZB	TORN.M24X 3X 80 U5737 10.9 ZB	SUR. M24X 3X 80 U5737 10.9 ZB
5	G18701590	RONDELLA 25X35X2,5 ZB	WASHER 25 x 35 x2,5 ZB	RONDELLE 25 x 35 x2,5 ZB	UNTERLEGSCHEIBE 25 x 35 x2,5	ARANDELA 25 x 35 x2,5 ZB	SAIBA 25X35X2,5 ZB
6	F01230144	DADO M24X 3 D982 8 ZN	SELF-LOCKING NUT NORM.24 ZB	ECROU AUTOB.NORM.24 ZB	SELBSTSPERR. MUTTER NORM.24 ZB	TUERCA AUTOB.NORM.24 ZB	PIUL.M24X 3 D982 8 ZN
7	G16740160	SCONTRIO AU SP.8 2F13 83	U-SHAPED STOP TEETH B343SP.8	BUTEE EN U SP.8 2F13 83	U-ANSCHLAG SP.8 2F13 83	DIENTE DE PARADAA U ESP.8	BRIDA U SP.8 2F13 83
8	F01020174	VITE M12X1,75X120 5737 8.8 ZN	BOLT 12X120 5737 8.8 GALVANIZ.	VIS 12X120 5737 8.8 ZN	SCHRAUBE 12X120 5737 8.8 ZN	TORNILLO 12X120 5737 8.8 ZN	SUR. M12X1,75X120 5737 8.8 ZB
9	F02200584	SPINA SICUR. D. 12X70 ZN	GALVAN. SAFETY PIN D.12X70	GOUVILLE DE S+CURIT+ D.12X70 Z	SCHERSTIFT D.12X70 ZN	PASADOR DE SEGURIDAD D 12X70 Z	STIFT DE SIGURANTAD.12X70 ZN
10	F01230059	DADO M12X1,75 D982 8 ZB	NUT M12X1,75 D982 8 ZB	ECRO.M12X1,75 D982 8 ZB	MUTT.M12X1,75 D982 8 ZB	TUER.M12X1,75 D982 8 ZB	PIUL.M12X1,75 D982 8 ZB
11	F20100112	PERNO D36 L128 C43 ZN	GASPARDO PIN 36X134 ZG	BROCHE GASPARDO 36X134 ZG	STIFT GASPARDO 36X134 ZG	CLAVIJA GASPARDO 36X134 ZG	STIFT GASPARDO 36X134 ZB

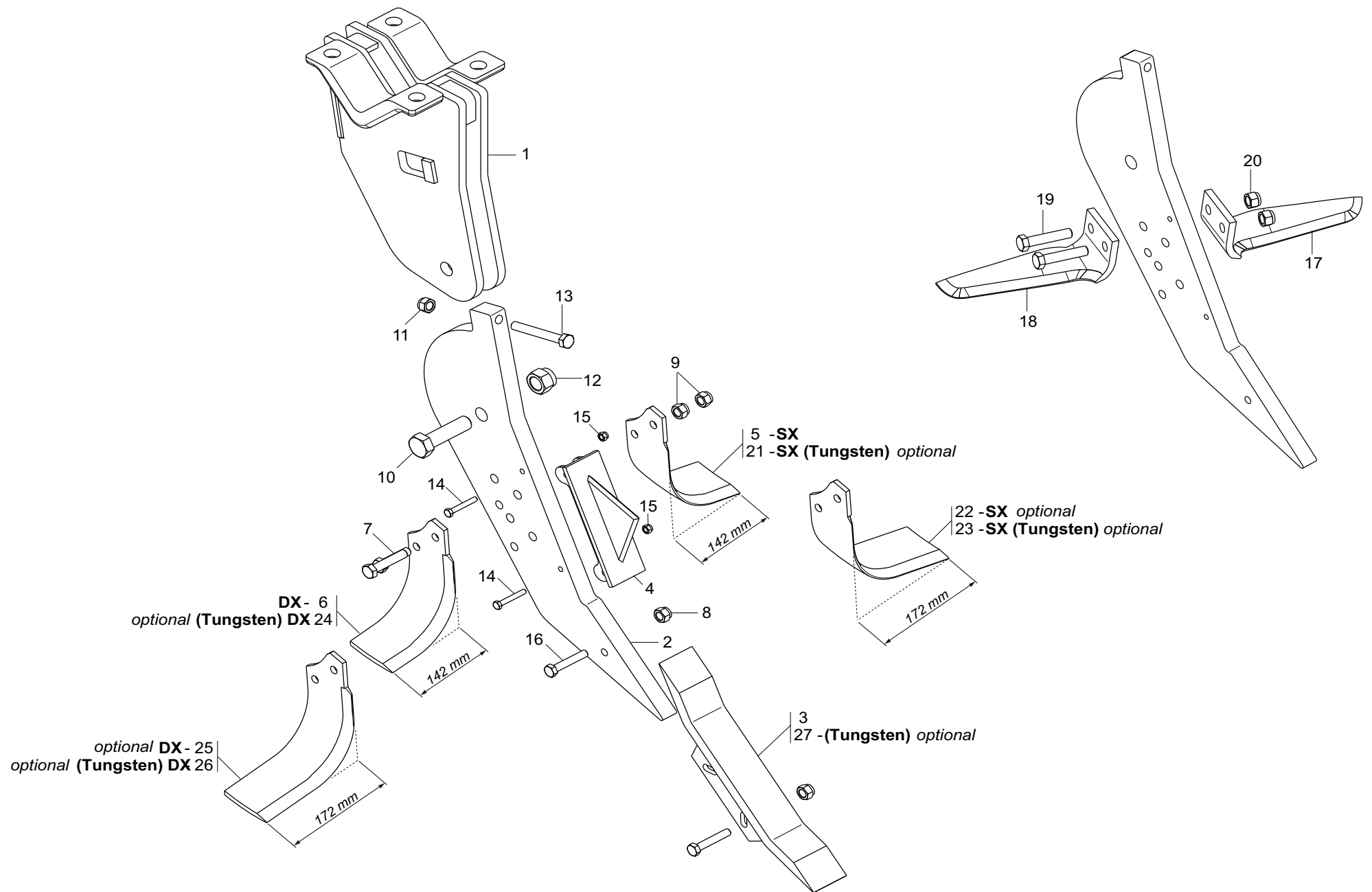

ELEMENTO OPERATORE

TAV. 020

Pos.	Cod.	Descrizione	Description	Description	Benennung	Descrpcion	Descriere
1	R17820540	SUPPORTO PUNTALE	TIP	SUPPORT EMBOUT	MESSERHALTER	SOPORTE PUNTAL	ANS.SUPPORT VARF
2	R17820561	LAMA	BLADE	LAME	MESSER	CUCHILLA	LAMA PROPTITOR
3	R17820681	ASSIEME DENTE	ANS. TOOTH	ANS. DENT	ZINKEN	DIENTE ATTILA	ANSAMBLU DINTE ATTILA
4	R17820411	ASSIEME LAMA SUPPORT	SUPPORT	LAME SUPPORT	MESSER	CUCHILLA SUPPORTO	ANSAMBLU LAMA SUPORT
5	M74100435	ZAPPA*AD ELICA DESTRA SP.10	RIGHT C BLADES (THICKNESS 10)	LAME HELICE DRT	RECHTES BOGENMESSER	AZADA HELICE DERECHA	SAPA ELICOIDALADREAPTA
6	M74100436	ZAPPA*AD ELICA SINISTRA SP.10	LEFT HELICOIDAL BLADE	LAME HELICE B-C-SC GCH	RECHTES BOGENMESSER	AZADA HELICE	SAPA ELICOIDALA STANGA
7	F01020207	SURUB M14X 2X 70 U5737 8.8 ZB	BOLTM 14X70	VIS M 14X70	SCHRAUBE M 14X70	TORNILLO M 14X70	SURUB M14X 2X 70 U5737 8.8 ZB
8	F01230059	DADO M12X1,75 D982 8 ZB	NUT M12X1,75 D982 8 ZB	ECROU.M12X1,75 D982 8 ZB	MUTT.M12X1,75 D982 8 ZB	TUER.M12X1,75 D982 8 ZB	PIUL.M12X1,75 D982 8 ZB
9	F01230073	PIULITA AUT.AM14X2 D982 8G Z	SELF LOCKING NUT M14X2	ECROU AUTOBL. M14X2	SELBSTSPMUTT. M14X2	DADO AUTOBL. M14X2	PIULITA AUT.AM14X2 D982 8G Z
10	F01020344	VITE M24X 3X100 U5737 10.9 ZD	SCREW 24X100 5737 10.9 ZN	VIS 24X100 5737 10.9 ZN	SCHRAUBE 24X100 5737 10.9 ZN	TORNILLO 24X100 5737 10.9 ZN	SUR. M24X100 5737 10.9 ZN
11	F01260046	DADO FLANG.M14 D6923 8.8 ZB	NUT M14 D6923 8.8 ZB	ECROU M14 D6923 8.8 ZB	MUTTER M14 D6923 8.8 ZB	TUERCA M14 D6923 8.8 B	PIULITA FLANG.M14 D6923 8.8 ZB
12	F01230144	DADO M24X 3 D982 8 ZN	SELF-LOCKING NUT NORM.24 ZB	ECROU AUTOB.NORM.24 ZB	SELBSTSPERR. MUTTER NORM.24 ZB	TUERCA AUTOB .NORM.24 ZB	PIUL.M24X 3 D982 8 ZN
13	F01020212	VITE M14X 2X 90 U5737 8.8 ZN	BOLT 14X90 5737 8.G GALV/ANIZ.	VIS 14X90 5737 8.G ZN	SCHRAUBE 14X90 5737 8.G ZN	TORNILLO 14X90 5737 8.G ZN	SURUB M14X 2X 90 U5737 8.8 ZB
14	F01020077	VITE M 8X1,25X60 U5737 8.8 ZG	BOLT M 8X60	VIS M 8X60	SCHRAUBE M 8X60	TORNILLO M 8X60	SURUBURI M8X1,25X60 U5737
15	F01230034	DADO M 8X1,25 D982 8	SELF LOCKING NUT M8X1,25	ECROU AUTOBL. M8X1,25	SELBSTSP.MUTT. M8X1,25	DADO AUTOBL. M8X1,25	PIULITA AUT.M8X1,25 D982 8G ZB
16	F01020162	VITE M12X1,75X65 U5737 8.8 ZG	BOLT M12X1,75X65 U5737 8.8 ZG	VIS M12X1,75X65 U5737 8.8 ZG	SCHRAUBE M12X1,75X65 U5737 8.8	TORNILLO M12X1,75X65 U5737 8.8	SUR. M12X1,75X65 U5737 8.8 ZB
17	M27100209	COLTELLO DC/DS/DL SX 90X12	COUNTERCLOCKWISE BLADE	COUTEAU DC-BR-CPR 12MM GCH	LINKES MESSER	CUCHILLO IZQUIERDO	CUTIT STINGA
18	M27100210	COLTELLO DC/DS/DL DX 90X12	CLOCKWISE BLADE	COUTEAU DC-BR-CPR 12MM DRT	RECHTES MESSER	CUCHILLO DERECHO	CUTIT DREAPTA
19	F01020263	VITE 16X80 5737 8.G *	SCREW 16X80 5737 8.G	VIS 16X80 5737 8.G *	SCHRAUBE 16X80 5737 8.G	TORNILLO 16X80 5737 8.G	SURUB M16X 2X 80 U5737 8.8
20	F01230085	DADO M16X 2 D982 8 ZB	NUT M16X 2 D982 8 ZB	ECROU M16X 2 D982 8 ZB	MUTT.M16X 2 D982 8 ZB	TUER.M16X 2 D982 8 ZB	PIUL.M16X 2 D982 8 ZB
21	R17820870	ZAPPAAD ELICA SX TUNGSTEN	LEFT HELICOIDAL BLADE TUNGSTEN	LAME HELICE B-C-SC GCH TUNGSTE	LINKES BOGENMESSER SX TUNGSTEN	AZADA HELICE IZQUIERDA TUNGSTE	SAPA ELICE SX TUNGSTEN
22	R17820820	ZAPPA ELICA SINISTRA	RIGHT HELICOIDAL BLADE	LAME HELICE B-C-SC GCH	RECHTES BOGENMESSER	AZADA HELICE DERECHA	SAPA SX
23	R17820890	ZAPPAAD ELICA SX P30 TUNGSTEN	LEFT HELICOIDAL BLADE P30 TG	LAME HELICE B-C-SC GCH P30 TG	LINKES BOGENMESSER SX P30 TG	AZADA HELICE IZQUIERDA P30 TG	SAPA ELICE SX P30 TUNGSTEN
24	R17820860	ZAPPA ELICA DESTRA TUNGSTEN	RIGHT HELICOIDAL BLADE TUNGSTEN	LAME HELICE B-C-SC DRT TUNGST	RECHTES BOGENMESSER TUNGSTEN	AZADA HELICE DERECHA TUNGSTEN	SAPAAD ELICE DX TUNGSTEN
25	R17820830	ZAPPA ELICA DESTRA P30	RIGHT HELICOIDAL BLADE P30	LAME HELICE B-C-SC DRT P30	RECHTES BOGENMESSER P30	AZADA HELICE DERECHA P30	SAPAAD ELICE DX P30
26	R17820880	ZAPPA ELICA DESTRA TG P30	RIGHT HELICOIDAL BLADE TG P30	LAME HELICE B-C-SC DRT TG P30	RECHTES BOGENMESSER TUNG. P30	AZADA HELICE DERECHA TG P30	SAPAAD ELICE DX TUNGSTEN P30
27	R17820731	ASS. DENTE TG	ANS. TOOTH TG	ANS. DENT TG	ZINKEN TG	DIENTE TG ATTILA	ANSAMBLU DINTE TG

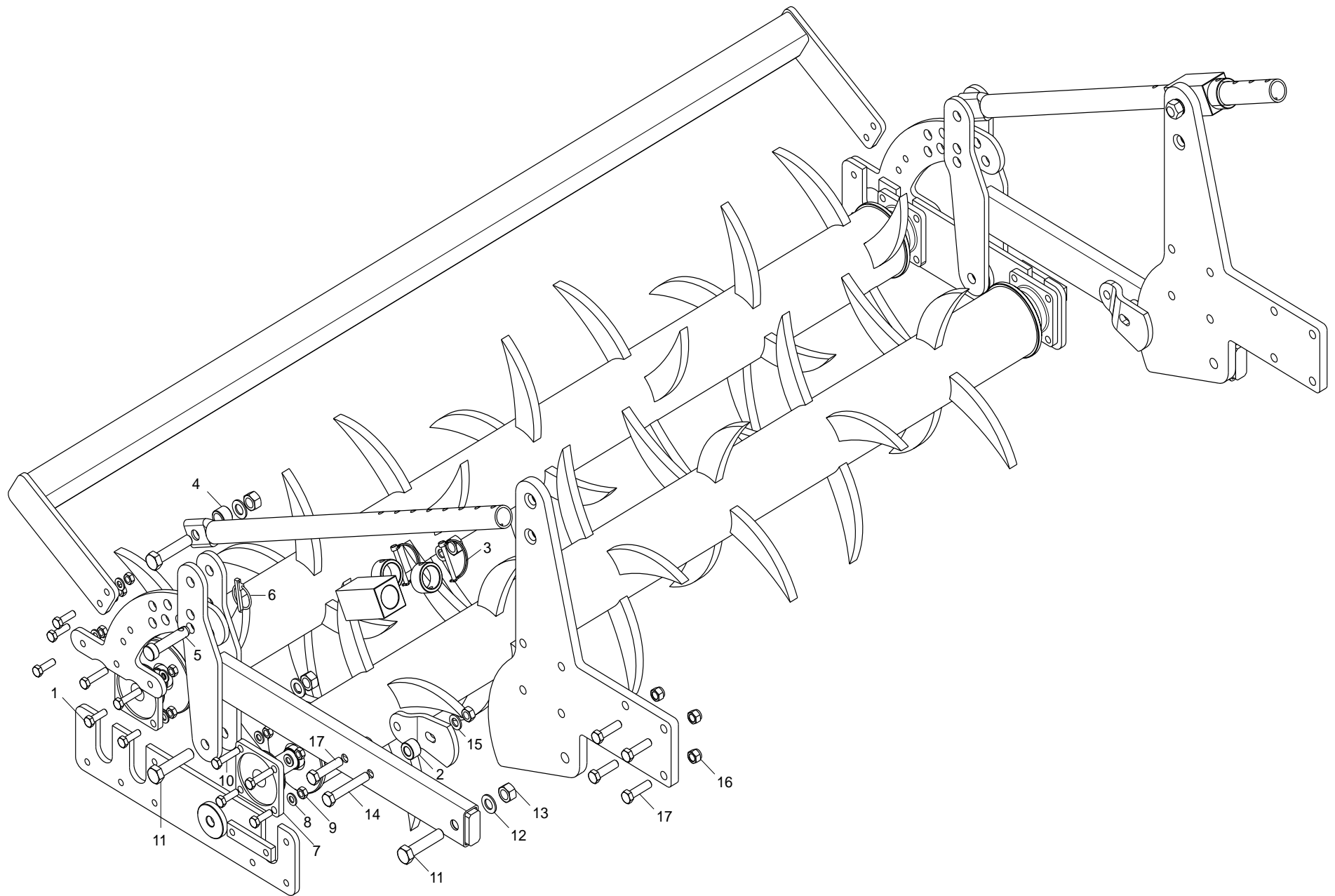

DOPPIO RULLO POSTERIORE MECCANICO

TAV. 030

Pos.	Cod.	Descrizione	Description	Description	Benennung	Descrpcion	Descriere
1	F01020152	VITE M12X1,75X40 U5737 8.8 ZB	BOLT M12X1,75X 40 5737 8.8 ZB	VIS M12X1,75X 40 5737 8.8 ZB	SCHR.M12X1,75X 40 5737 8.8 ZB	TORN.M12X1,75X 40 5737 8.8 ZB	SUR.M12X1,75X 40 5737 8.8 ZB
2	R17813230	BOCCOLA	BUSCHING	BOITE	BsCHSE	CASQUILLO	BUCSADISTANTATOARE
3	F02200562	SPINA SICUR. D. 8X70 ZN	SPLIT PIN D.8X70 ZB	GOUPILLE D.8X70 ZB	BOLZEN D.8X70 ZB	PERNO D.8X70 ZB	STIFT DE SIGURANTAD.8X70 ZB
4	R17812000	BOCCOLA 21,7X33,7X23 ZN	BUSHING 21,7X33,7X23 ZN	BOITE 21,7X33,7X23 ZN	BsCHSE 21,7X33,7X23 ZN	CASQUILLO 21,7X33,7X23 ZN	BUCSA 21,7X33,7X23 ZN
5	R17813310	PERNO	SCREW	VIS	SCHRAUBE	TORNILLO	BOLT DE POZITIE ZB
6	F02200507	SPINA SCATTO D. 9 B/83 ZN	SNAP PIN D 9 B/83	FICHE A DETENTE D 9 B/83	EINRASTSTIFT D 9 B/83	CLAVIJA DE MUELLE D 9 B/83	STIFT RESORT D 9 ZB B/83
7	F04100073	SUPPORTO CUSCINETTO FY35TF	BEARING SUPPORT	SUPPORT ROULEMENT	LAGERHALTERUNG	SOPORTE COJINETE	SUPORT RULMENT FY35TF
8	F01410076	RONDELLA D12 UNI 6592 ZN	PLANE WASHER D12 UNI 6592 ZN	RONDELLE D12 UNI 6592 ZN	SCHEIBE D12 UNI 6592 ZN	ARANDELA D12 UNI 6592 ZN	SAIBA PLANA D12 UNI 6592 ZB
9	F01230059	DADO M12X1,75 D982 8 ZB	NUT M12X1,75 D982 8 ZB	ECRO.M12X1,75 D982 8 ZB	MUTT.M12X1,75 D982 8 ZB	TUER.M12X1,75 D982 8 ZB	PIUL.M12X1,75 D982 8 ZB
10	F01020160	VITE M12X1,75X60 U5737 8.8 ZG	BOLT M12X1,75X60 U5737 8.8 ZG	VIS M12X1,75X60 U5737 8.8 ZG	SCHRAUBE M12X1,75X60 U5737 8.8	TORNILLO M12X1,75X60 U5737 8.8	SURUB M12X1,75X 60 5737 8.8 ZB
11	F01020325	VITE M20X2,5X90 U5737 10.9 ZD	BOLT 20X90 5737 10.9G GALVANI	VIS 20X90 5737 10.9G ZN	SCHRAUBE 20X90 5737 10.9G ZN	TORNILLO 20X90 5737 10.9G ZN	SURUB 20X90 5737 10.9 ZN
12	F01410124	ROS.M20 21X 37X 3 U6592 ZG	PLANE WASHER D20 UNI 6592 ZN	RONDELLE D20 UNI 6592 ZN	SCHEIBE D20 UNI 6592 ZN	ARANDELLA D20 UNI 6592 ZN	SAIBA PLANA D20 UNI 6592 ZB
13	F01230131	DADO M20X 2,5 D982 6 ZB	NUT M20X 2,5 D982 6 ZB	ECRO.M20X 2,5 D982 6 ZB	MUTT.M20X 2,5 D982 6 ZB	TUER.M20X 2,5 D982 6 ZB	PIUL.M20X 2,5 D982 6 ZB
14	F01020285	VITE M16X 2X100 U5737 8.8 ZN	BOLT 16X100 5737 8.8 GALVANIZ	VIS 16X100 5737 8.8 ZN	SCHRAUBE 16X100 5737 8.8 ZN	TORNILLO 16X100 5737 8.8 ZN	SURUB 16X100 5737 8.8 ZN
15	F01410100	ROS.M16 17X 30X 3 U6592 ZG	PLANE WASHER D16 UNI 6592 ZN	RONDELLE D16 UNI 6592 ZN	SCHEIBE D.16 UNI 6592 ZN	ARANDELA D16 UNI 6592 ZN	SAIBA M16 17X 30X 3 U6592 ZB
16	F01230085	DADO M16X 2 D982 8 ZB	NUT M16X 2 D982 8 ZB	ECROU M16X 2 D982 8 ZB	MUTT.M16X 2 D982 8 ZB	TUER.M16X 2 D982 8 ZB	PIUL.M16X 2 D982 8 ZB
17	F01030152	VITE M16X 2X70 U5933 8.8 ZN	BOLT M16X2X70 U5933 8.8 ZB	VIS M16X2X70 U5933 8.8 ZB	SCHRAUBE M16X2X70 U593308.8 ZN	TORNILLO M16X2X70 U5933 8.8 ZB	SUR.M16X2X70 U5933 8.8 ZB

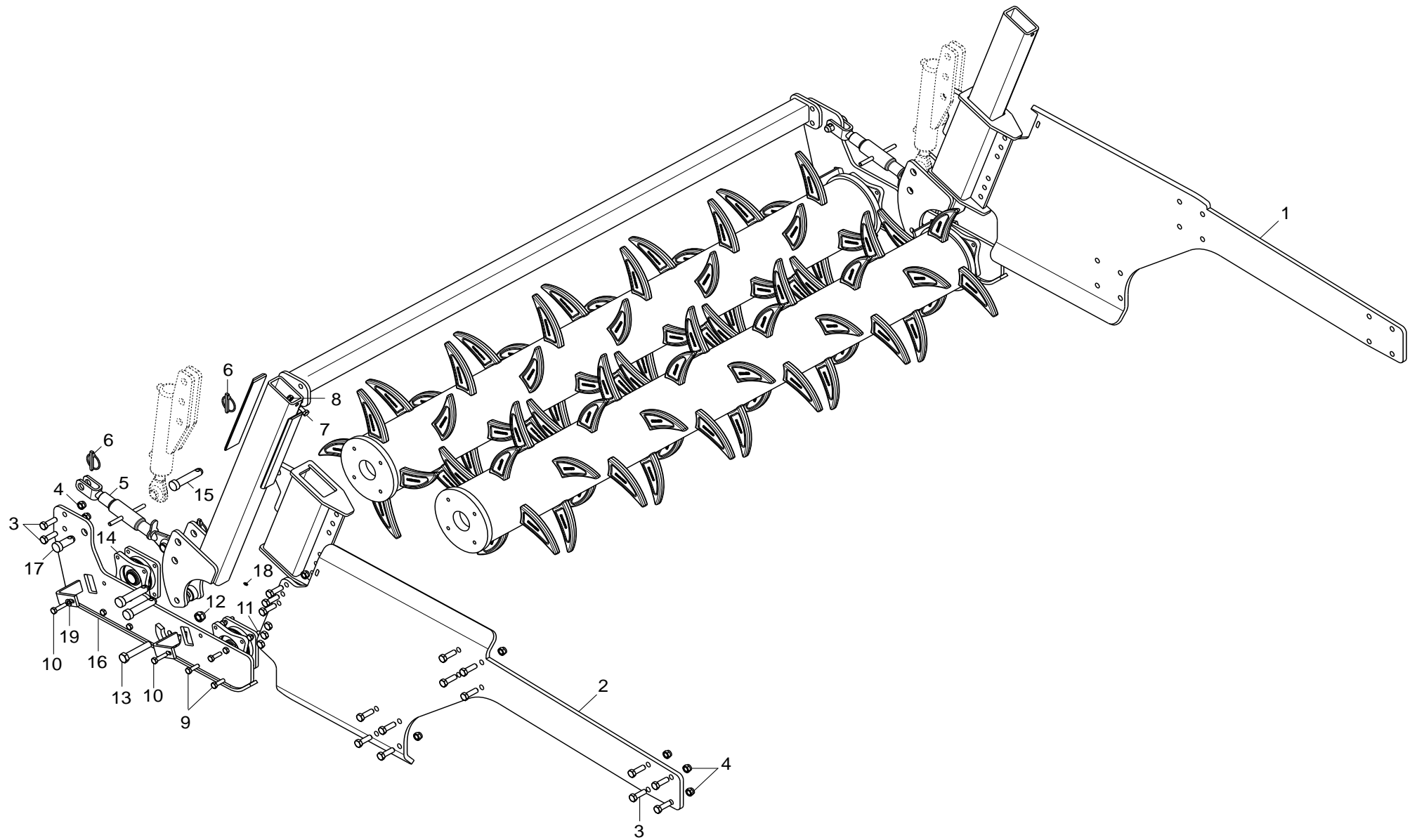

DOPPIO RULLO POSTERIORE OLEODINAMICO

TAV. 040

Pos.	Cod.	Descrizione	Description	Description	Benennung	Descripcion	Descriere
1	R17815761	LAMA SUPPORTO REGOLAZIONE SX	SUPPORT BLADE ADJUSTMENT SX	SUPPORT LAME REGLAGE SX	HALTERUNG MESSER SX	CUCHILLA SOPORTE SX	LAMA SUPORT REGLARE SX
2	R17815751	PIASTRA SOPORTO REGOLAZIONE SX	LEFT BLADE SUPPORT	LAMA SUPPORT GCH	MESSER SUPPORT SX	CUCHILLA SOPORTO SX	LAMA SUPORT REGLARE SX
3	F01020252	VITE M16X 2X50 U5737 8.8 ZB	BOLT M16X 2X50 U5737 8.8 ZB	VIS M16X 2X50 U5737 8.8 ZB	SCHR.M16X 2X50 U5737 8.8 ZB	TORN.M16X 2X50 U5737 8.8 ZB	SUR. M16X 2X50 U5737 8.8 ZB
4	F01230085	DADO M16X 2 D982 8 ZB	NUT M16X 2 D982 8 ZB	ECROU M16X 2 D982 8 ZB	MUTT.M16X 2 D982 8 ZB	TUER.M16X 2 D982 8 ZB	PIUL.M16X 2 D982 8 ZB
5	F02450022	CILINDRO L=330 L=490 D25,4 ZD	CYLINDER L=330 L=490 D25,4 ZD	CYLINDRE L=330 L=490 D=25,4 ZD	ZYLINDER L=330 L=490 D=25,4 ZD	CILINDRO L=330 L=490 D25,4 ZD	CILINDRU L=330 L=490 D=25,4 ZD
6	F02200507	SPINA SCATTO D. 9 B/83 ZN	SNAP PIN D 9 B/83	FICHE A DETENTE D 9 B/83	EINRASTSTIFT D 9 B/83	CLAVIJA DE MUELLE D 9 B/83	STIFT RESORT D 9 ZB B/83
7	F01020508	VITE M12X1,75X25 U5739 8.8 ZN	BOLT M 12X25	VIS M 12 X 25	SCHRAUBE M 12 X 25	TORNILLO M 12 X 25	SURUB M12X1,75X25 U5739 8.8 ZN
8	F01230059	DADO M12X1,75 D982 8 ZB	NUT M12X1,75 D982 8 ZB	ECRO.M12X1,75 D982 8 ZB	MUTT.M12X1,75 D982 8 ZB	TUER.M12X1,75 D982 8 ZB	PIUL.M12X1,75 D982 8 ZB
9	F01010288	VITE M12X1,25X35 U5740 8.8 ZN	SCREW M12X1,25X35 U5740 8.8 ZB	VIS M12X1,25X35 U5740 8.8 ZB	SCHR.M12X1,25X35 U5740 8.8 ZB	TORN.M12X1,25X35 U5740 8.8 ZB	SUR. M12X1,25X35 U5740 8.8 ZB
10	F01010292	VITE M12X1,25X45 U5740 8.8 ZG	BOLT M12X1,25X45 U5740 8.8 ZG	VIS M12X1,25X45 U5740 8.8 ZG	SCHRAUBE M12X1,25X45 U5740 8.8 ZB	TORNILLO M12X1,25X45 U5740 8.8 ZB	SUR. M12X1,25X45 U5740 8.8 ZB
11	F01020528	VITE M12X1,75X40 U5739 10.9 ZD	SCREW 12X40 5739 10.9 ZN	VIS 12X40 5739 10.9 ZN	SCHRAUBE 12X40 5739 10.9 ZN	TORNILLO 12X40 5739 10.9 ZN	SURUB 12X40 5739 10.9 ZN
12	F01230131	DADO M20X 2,5 D982 6 ZB	NUT M20X 2,5 D982 6 ZB	ECRO.M20X 2,5 D982 6 ZB	MUTT.M20X 2,5 D982 6 ZB	TUER.M20X 2,5 D982 6 ZB	PIUL.M20X 2,5 D982 6 ZB
13	F01020313	VITE M20X2,5X110 U5737 8.8 ZN	BOLT 20X110 5737 8.8 GALVANIZ.	VIS 20X110 5737 8.8 ZN	SCHRAUBE 20X110 5737 8.8 ZN	TORNILLO 20X110 5737 8.8 ZN	SURUB 20X110 5737 8.8 ZN
14	R17015300	ASSIEME CUSCINETTO	BEARING SUPPORT	SUPPORT ROULEMENT	LAGERHALTERUNG	SOPORTE COJINETE	ANSAMBLU LAGAR
15	F20100063	PERNO D25 L91 C40 ZN	PIN GASPARDO D25 L113 C40	PIVOT GASPARDO D25 L113 C40	BOLZEN GASPARDO D25 L113 C40	PERNO GASPARDO D25 L113 C40	BOLT GASPARDO D25 L113 C40
16	R17811403	ASS. SUPPORTO RULLO	FRAME ROLLER	SUPPORT ROULEAU	ROLLE HALTERUNG	SOPORTE RODILLO	ANS. SUPORT RULOU
17	R17817910	PERNO ZB	PIN ZB	PIVOT ZB	BOLZEN ZB	PERNO ZB	BOLT ZB
18	F01100011	ING.M 6X1 7663-A9SMNPB28 ZN	SPHERE NIPPLE M6X1/A	GRAISSEUR A BILLES M6X1/A	KUGELFETTBSCHSE M6X1/A	ENGRAS. DE ESFERAS M6X1/A	ING.M 6X1 7663-A9SMNPB28 ZB
19	F01410076	RONDELLA D12 UNI 6592 ZN	PLANE WASHER D12 UNI 6592 ZN	RONDELLE D12 UNI 6592 ZN	SCHEIBE D12 UNI 6592 ZN	ARANDELA D12 UNI 6592 ZN	SAIBA PLANA D12 UNI 6592 ZB

TAV. 050

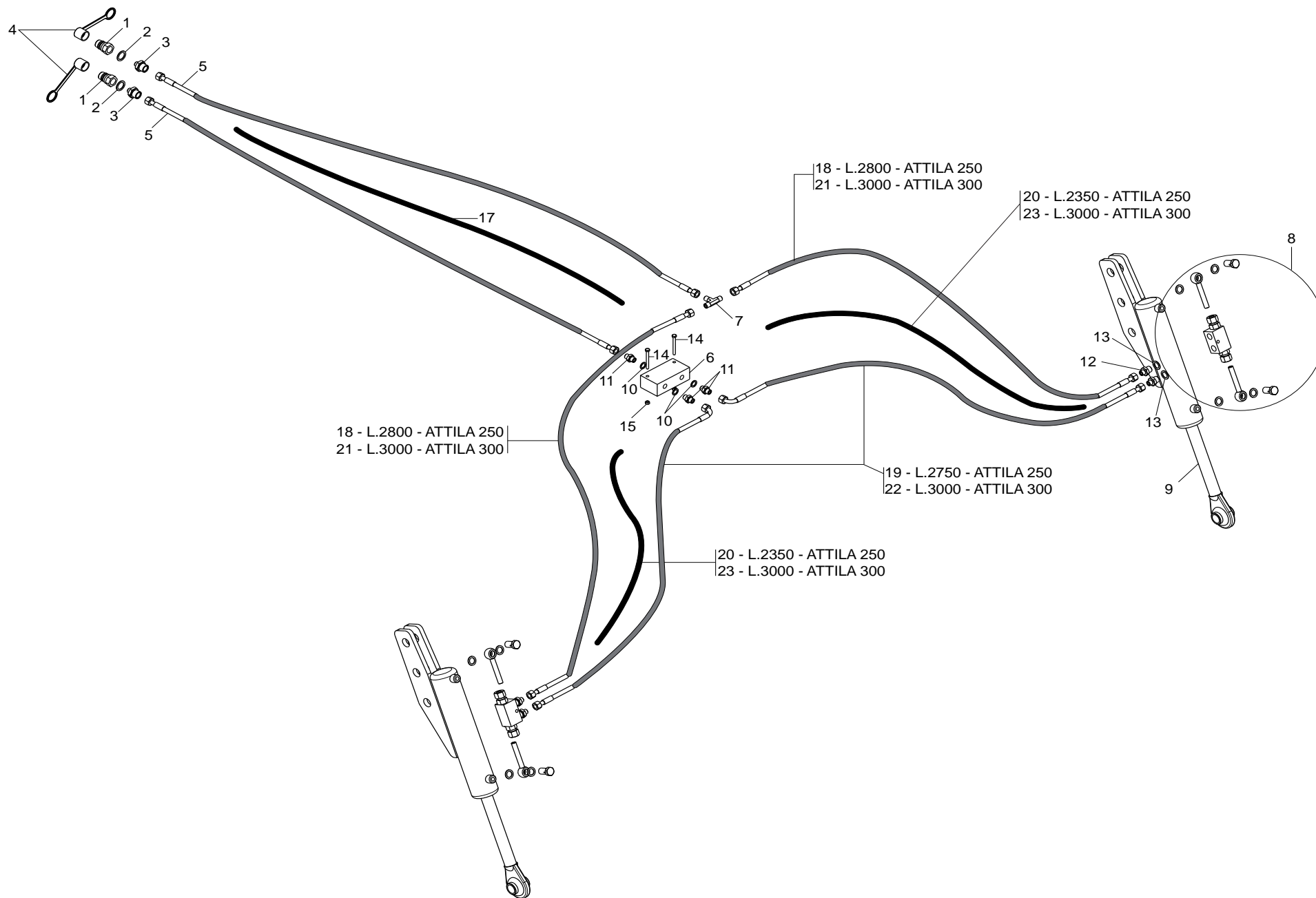

IMPIANTO OLEODINAMICO RULLI POSTERIORI

TAV. 050

Pos.	Cod.	Descrizione	Description	Description	Benennung	Descrpcion	Descriere
1	F03150935	INNESTO RAP.MASCH.1/2 A VALV.	QUICK CONNECT MALE CONE 1/2 CO	CONNEXION RAPIDE MALE CONE 1/2	SCHNELLKUPPLUNG GEWINDE KONISC	ACOPLAMIENTO RAPIDO MACHO CONO	CONECTARE RAPIDATA.TATA.CU 1/2
2	F03151237	RONDELLA RAME 21X27X1,5 -1/2"	1/2 COPPER WASHER	RONDELLE CUIVRE 1/2	UNTERLEGSCHIEBE KUPFER 1/2	ARANDELA COBRE 1/2	SAIBA RAME 1/2
3	F03150211	NIPPLO MM CIL-CIL 1/2-1/4 ZN	NIPLE 1/4-1/2	NIPLE 1/4-1/2	NIPLE 1/4-1/2	NIPLE 1/4-1/2	NIPLU 1/4-1/2
4	F05150325	CAPPUCCIO PROT.INNESTO RAP.1/2	COVER 1/2	COUVERCLE 1/2	DECKEL 1/2	TAPA 1/2	GLUGA CONECTARE 1/2
5	R17817920	TUBO 1/4 FF L=2000	PIPE 1/4 FF L=2000	TUBE 1/4 FF L=2000	ROHR 1/4 FF L=2000	TUBO 1/4 FF L=2000	TUB 1/4 FF L=2000
6	F03151044	DIVISORE DI FLUSSO A 2 VIE	FLOW DIVISOR	DIVISEUR DE FLUX	OELVERTEILER	DIVISOR DE FLUJO	DIVIZOR FLUX
7	F03151219	RACCORDO -T- MASCHIO 1/4 ZN	MALE T-UNION 1/4 ZINC.	RACCORD -T- MALE 1/4 ZING.	ANSCHLUSSTsCK -T- GEWINDE 1/4	UNIN -T- MACHO 1/4 CINC. R	ACORD -T- TATA 1/4 ZINC. R
8	F03151158	KIT VALVOLABLOCCO 3/8 7014200	KIT CHECK VALVES 3/8 7014200	KIT CLAPET DE BLOCAGE 3/8	KIT RUCKSCHLAGVENTIL 3/8	KIT VALVULAANTIRATORNO 3/8	KIT VALVABLOC 3/8 7014200
9	R17811481	CILINDRO 30X70 - 280	CYLINDER 30X70 - 280	CYLINDRE 30X70 - 280	ZYLINDER 30X70 - 280	CILINDRO 30X70 - 280	ANSAMBLU CILINDRU 30X70 - 280
10	F03151238	RONDELLA RAME 13X19X1,5 -1/4"	1/4 COPPER WASHER	RONDELLE CUIVRE 1/4	UNTERLEGSCHIEBE KUPFER 1/4	ARANDELA COBRE 1/4	SAIBA RAME 1/4
11	F03150266	NIPPLO MM CIL-CIL 1/4-1/4 ZN	NIPPLE GALV.CYL.MALE 1/4 ZN	NIPPLE MALE CYL. 1/4 ZN	NIPPELZYL.1/4 ZN	NIPLE MACHO CIL.1/4 ZN	NIPLU TATA CIL.1/4 ZN
12	F03150310	NIPPLO MM CIL-CIL 3/8-1/4 ZN	NIPPLE GALV.CYL.MALE3/8-1/4 ZN	NIPPLE MALE CYL.3/8-1/4 ZN	NIPPELZYL.3/8-1/4 ZN	NIPLE MACHO CIL.3/8-1/4 ZN	NIPLU TATA CIL.3/8-1/4 ZN
13	F03151240	RONDELLA RAME 3/8	3/8 COPPER WASHER	RONDELLE CUIVRE 3/8	UNTERLEGSCHIEBE KUPFER 3/8	ARANDELA COBRE 3/8	SAIBA RAME 3/8
14	F01020416	VITE M 6X 1X 55 U5739 8.8 ZN	BOLT M 6X 1X 55 U5739 8.8 ZN	VIS M 6X 1X 55 U5739 8.8 ZN	SCHR.M 6X 1X 55 U5739 8.8 ZN	TORN.M 6X 1X 55 U5739 8.8 ZN	SUR. M 6X 1X 55 U5739 8.8 ZN
15	F01220011	DADO M 6X 1 D980 8 ZG	SELF LOCKING NUT M6	ECROU AUTOBL. M6	SELBSTSPERR.MUTTER M6	DADO AUTOBL. M6	PIULITA AUTOFRINARE M6 USM8-98
16	F05150058	FASCETTA POLYAM.7,8X550 31920	POLYAMIDE FASTENING STRAPS 9X5	COLLIER POLYAMIDE 9X508 31920	SHELLE POLYAMID 9X508 31920	ABRAZADERA POLIAMIDA 9X508 319	COLIER PLASTIC 9X508 31920
17	F03100383	GUAINA TELATA D=65 L=1750	SHEATH D=65 L=1750	GAINE D=65 L=1750	KABEL D=65 L=1750	VAINA D=65 L=1750	PROTECTIE TEXTILA D=65 L=1750
18	G17915100	TUBO 1/4 F-F L.2800	PIPE 1/4 F-F L.2800	TUBE 1/4 F-F L.2800	ROHR 1/4 F-F L.2800	TUBO 1/4 F-F L.2800	TUB 1/4 F-F L.2800
19	G15210551	TUBO 1/4R2 C-F L.2750 LM	PIPE 1/4R1 C-F L.2750 LM	TUBE 1/4R1 C-F L. 2750 LM	ROHR 1/4R1 C-F L.2750 LM	TUBO 1/4R1 C-F L.2750 LM	TUB 1/4R2 C-F L.2750 LM
20	F03100362	GUAINA TELATA D=65 L=2350	SHEATH D=65 L=2350	GAINE D=65 L=2350	KABEL D=65 L=2350	VAINA D=65 L=2350	PROTECTIE TEXTILA D=65 L=2350
21	R17814480	TUBO 1/4R2 F1/4-F1/4 L=3000	PIPE 1/4R2 F1/4-F1/4 L=3000	TUBE 1/4R2 F1/4-F1/4 L=3000	ROHR 1/4R2 F1/4-F1/4 L=3000	TUBO 1/4R2 F1/4-F1/4 L=3000	TUB 1/4R2 F1/4-F1/4 L=3000
22	G15210631	TUBO 1/4R2 C-F L.3000 LM	PIPE 1/4R2 C-F L.3000 LM	TUBE 1/4R2 C-F L. 3000 LM	ROHR 1/4R2 C-F L.3000 LM	TUBO 1/4R2 C-F L.3000 LM	TUB 1/4R2 C-F L.3000 LM
23	F03100371	GUAINA TELATA D=65 L=3000	SHEATH D=65 L=3000	GAINE D=65 L=3000	KABEL D=65 L=3000	VAINAD=65 L=3000	PROTECTIE D=65 L=3000

TAV. 060

BATTERIA DISCHI D.710 - 2,5m - 17
 BATTERIA DISCHI D.710 - 3,0m - 19
 BATTERIA DISCHI D.660 - 2,5m - 20
 BATTERIA DISCHI D.660 - 3,0m - 21

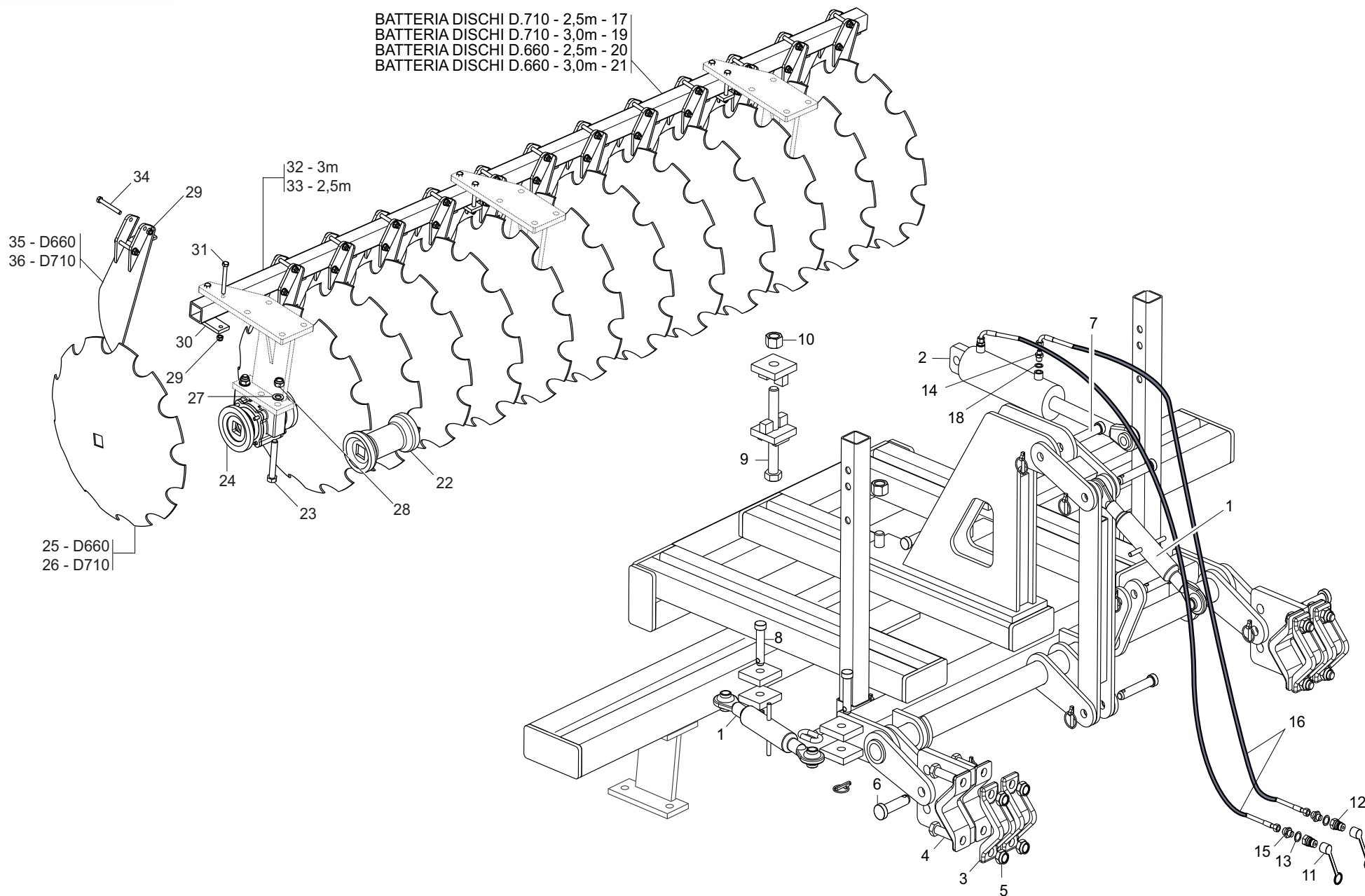

DISCHI POSTERIORI

TAV. 060

Pos.	Cod.	Descrizione	Description	Description	Benennung	Descrpcion	Descriere
1	R17815000	TIRANTE TERZO PUNTO 19678	TIE-ROD THIRD POINT 19678	TRINGLE TROISIEME POINT 19678	ZUGSTANGE DRITTER PUNKT 19678	TIRANTE TERCER PUNTO 19678	TIRANT 3 PUNCTE 19678
2	G15313210	CILINDRO CARRELLA DIRECTA	CYLINDER CARRIAGE DIRECTA	CYLINDRE CHARIOT DIRECTA	ZYLINDER WAGEN DIRECTA	CILINDRO CARRETTILLA DIRECTA	CILINDRU CARUCIOR DIRECTA
3	R17811170	SCONTRO PER TUBO 100	STRIKER PLATE 100	BUTEE 100	ANSCHLAG 100	ELEMENTO DE EMPALME 100	BRIDA FIXARE TEAVA 100
4	F01020343	VITE M24X 3X 80 U5737 10.9 ZD	BOLT M24X 3X 80 U5737 10.9 ZB	VIS M24X 3X 80 U5737 10.9 ZB	SCHR.M24X 3X 80 U5737 10.9 ZB	TORN.M24X 3X 80 U5737 10.9 ZB	SUR.M24X 3X 80 U5737 10.9 ZB
5	F01230144	DADO M24X 3 D982 8 ZN	SELF-LOCKING NUT NORM.24 ZB	ECROU AUTOB.NORM.24 ZB	SELBSTSPERR. MUTTER NORM.24 ZB	TUERCA AUTOB .NORM.24 ZB	PIUL.M24X 3 D982 8 ZN
6	F20100078	PERNO D28 L93 C43 ZN	PIN D.28	GOUJON D.28	BOLZEN D.28	PERNO D.28	STIFT GASPARDO 28X99 ZN
7	F20100063	PERNO D25 L91 C40 ZN	PIN GASPARDO D25 L113 C40	PIVOT GASPARDO D25 L113 C40	BOLZEN GASPARDO D25 L113 C40	PERNO GASPARDO D25 L113 C40	BOLT GASPARDO D25 L113 C40
8	F20100062	SPINA GASPARDO 25X128 ZN	FOR 3RD POINT	GOUJON 3EME POINT	BOLZEN 3. PUNKT	PERNO 3 PUNTO	PIVOT D.25
9	F01020356	VITE M30X 3,5X260 U5737 8.8 ZN	BOLT M30X 3,5X260 U5737 8.8 ZG	VIS M30X 3,5X260 U5737 8.8 ZG	SCHRAUBE M30X 3,5X260 U5737	TORNILLO M30X 3,5X260 U5737	SURUB M30X 3,5X260 U5737 8.8
10	F01210085	DADO M30X 3,5 U5593 5.8 ZN	NUT M30X 3.5 U5593 5.8 ZB	ECROU M30X 3.5 U5593 5.8 ZB	MUTTER M30X 3.5 U5593 5.8 ZB	TORN. M30X 3.5 U5593 5.8 ZB	PIULITA M30X 3.5 U5593 5.8 ZB
11	F05150325	CAPPUCCIO PROT.INNESTO RAP.1/2	COVER 1/2	COUVERCLE 1/2	DECKEL 1/2	TAPA 1/2	GLUGA CONECTARE 1/2
12	F03150835	INNESTO RAP.MASCH.1/2 A VALV.	QUICK CONNECT MALE CONE 1/2 CO	CONNEXION RAPIDE MALE CONE 1/2	SCHNELLKUPPLUNG GEWINDE KONISC	ACOPLAMIENTO RAPIDO MACHO CONO	CONECTARE RAPIDA TATA.CU 1/2
13	F03151237	RONDELLA RAME 21X27X1,5 -1/2"	1/2 COPPER WASHER	RONDELLE CUIVRE 1/2	UNTERLEGSCHIEBE KUPFER 1/2	ARANDELA COBRE 1/2	SAIBA RAME 1/2
14	F03150310	NIPPLO MM CIL-CIL 3/8-1/4 ZN	NIPPLE GALV.CYL.MALE3/8-1/4 ZN	NIPPLE MALE CYL.3/8-1/4 ZN	NIPPELZYL.3/8-1/4 ZN	NIPLE MACHO CIL.3/8-1/4 ZN	NIPLU TATA CIL.3/8-1/4 ZN
15	F03150211	NIPPLO MM CIL-CIL 1/2-1/4 ZN	NIPLE 1/4-1/2	NIPLE 1/4-1/2	NIPLE 1/4-1/2	NIPLE 1/4-1/2	NIPLU 1/4-1/2
16	G15413060	TUBO 1/4R2 CF1/4-F1/4 3850	TUBE 1/4R2 CF1/4-F1/4 3850	TUYAU 1/4R2 CF1/4-F1/4 3850	SCHLAUCH 1/4R2 CF1/4-F1/4 3850	TUBO 1/4R2 CF1/4-F1/4 3850	TUBO 1/4R2 CF1/4-F1/4 3850
17	R17818050	BATTERIA DEI DISCHI 2.5M	BATTERY DISK 2.5M	BATTERIE DU DISQUE	SCHIEBEN 2.5M	DISCHI 2.5M	BATERIE DISC 2.5M
18	F03151240	RONDELLA RAME 3/8	3/8 COPPER WASHER	RONDELLE CUIVRE 3/8	UNTERLEGSCHIEBE KUPFER 3/8	ARANDELA COBRE 3/8	SAIBA RAME 3/8
19	R17818030	BATTERIA DEI DISCHI 3M	BATTERY DISK 3M	BATTERIE DU DISQUE 3M	SCHIEBEN 3M	DISCHI 3M	BATERIE DISC 3M
20	R17818110	BATTERIA DEI DISCHI 2.5M D=660	BATTERY DISK 2.5M D=660	BATTERIE DU DISQUE 2,5M D=660	SCHIEBEN 2,5M D=660	DISCHI 2,5M D=660	BATERIE DISC 2,5M D=660
21	R17818120	BATTERIA DEI DISCHI 3M D=660	BATTERY DISK 3M D=660	BATTERIE DU DISQUE 3M D=660	SCHIEBEN 3M D=660	DISCHI 3M D=660	BATERIE DISC 3M D=660
22	R18420090	DISTANZIALE L=230	SPACER	ENTRETOISE	ABSTANDST_CK	DISTANCIADOR	DISTANTIER L=230
23	F01010178	VITE M20X1,5X140 U5738 8.8 ZN	BOLT M20X1,5X140 U5738 8.8 ZN	VIS M20X1,5X140 U5738 8.8 ZN	SCHRAUBE M20X1,5X140 U5738 8.8	TORNILLO M20X1,5X140 U5738 8.8	SURUB M20X1,5X140 U5738 8.8 ZN
24	R18420110	ASSIEME MOZZO	CLUTCH	EMBRAYAGE	KUPPLUNG	FRICCION	ANSAMBLU BUTUC
25	R18420300	DISCO D=660	DISK D=660	DISQUE D=660	SCHIEBE D=660	DISCO D=660	DISC D=660
26	R17816690	DISCO 710	DISK 710	DISQUE 710	SCHIEBE D710	DISCO 710	DISC 710
27	F01430105	ROS.M20 21X 33X1,4 U8842J BR	WASHER D20 DIN 6798 D. INT. *	RONDELLE D20 DIN 6798 D.INT. *	UNT.SCHIEBE D20 DIN 6798 D.INT	ARANDELA D20 DIN 6798 D.INT. *	SAIBA M20 21X33X1,4 U8842J BR
28	F01230131	DADO M20X 2,5 D982 6 ZB	NUT M20X 2,5 D982 6 ZB	ECRO.M20X 2,5 D982 6 ZB	MUTT.M20X 2,5 D982 6 ZB	TUER.M20X 2,5 D982 6 ZB	PIUL.M20X 2,5 D982 6 ZB
29	F01230059	DADO M12X1,75 D982 8 ZB	NUT M12X1,75 D982 8 ZB	ECRO.M12X1,75 D982 8 ZB	MUTT.M12X1,75 D982 8 ZB	TUER.M12X1,75 D982 8 ZB	PIUL.M12X1,75 D982 8 ZB
30	R18420230	PIASTRA FISSAGIO	BLADE	LAME	MESSER	CUCHILLA	PLACA DE FIXARE
31	F01020174	VITE M12X1,75X120 5737 8.8 ZN	BOLT 12X120 5737 8.8 GALVANIZ.	VIS 12X120 5737 8.8 ZN	SCHRAUBE 12X120 5737 8.8 ZN	TORNILLO 12X120 5737 8.8 ZN	SUR. M12X1,75X120 5737 8.8 ZB
32	R18420280	TUBO 60X60X6 L=3100	TUBE 60X60X6 L=3100	TUBE 60X60X6 L=3100	ROHR 60X60X6 L=3100	TUBO 60X60X6 L=3100	TUB 60X60X6 L=3100
33	R17860010	TUBO 60X60X6 L=2500	TUBE 60X60X6 L=2500	TUBE 60X60X6 L=2500	ROHR 60X60X6 L=2500	TUBO 60X60X6 L=2500	TUB 60X60X6 L=2500
34	F01020170	VITE M12X1,75X100 5737 8.8 Z	BOLT M 12X100	VISM 12X100	SCHRAUBE M 12X100	TORNILLO M 12X100	SURUB M12X1,75X100 5737 8.8 ZB
35	R18420270	RASCHIATERRA	SOIL SCRAPER	DECROITTOIR	ABSTREIFER	RASCADOR	RAZUITOARE
36	R17860020	RASCHIATERRA	SOIL SCRAPER	DECROITTOIR	ABSTREIFER	RASCADOR	RAZUITOARE

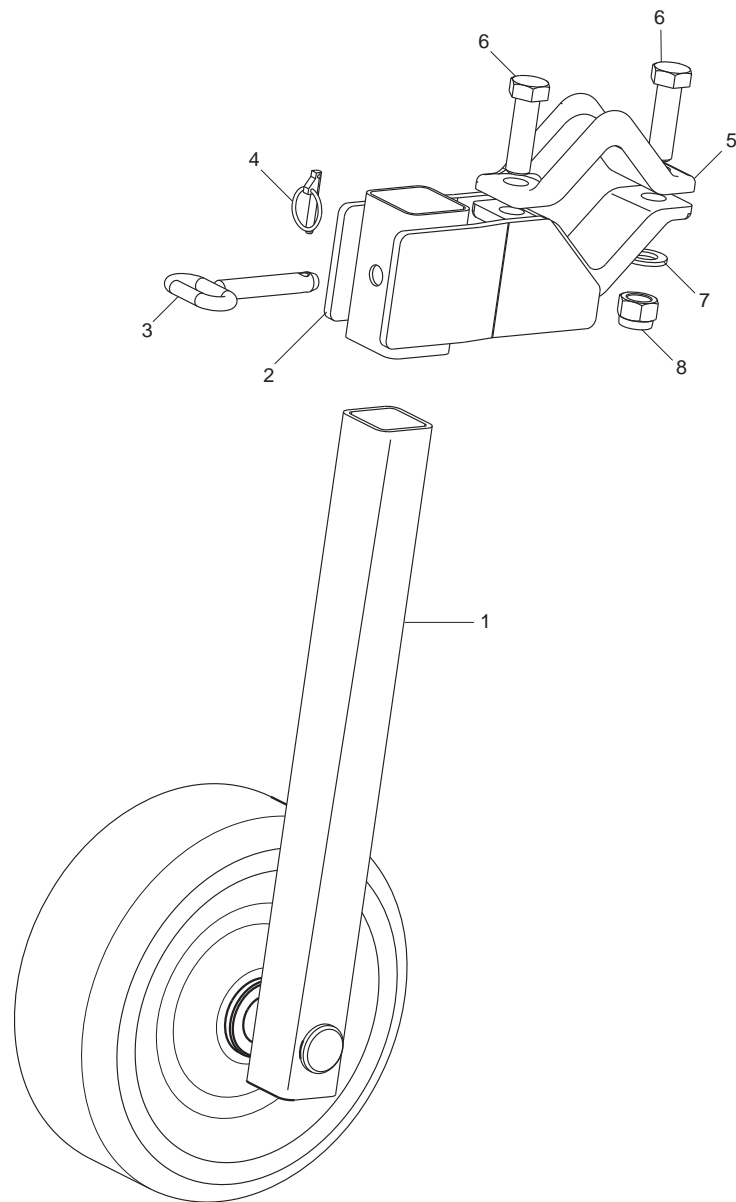

RUOTE DI SOSTEGNO

TAV. 070

Pos.	Cod.	Descrizione	Description	Description	Benennung	Descripcion	Descriere
1	R18012160	RUOTA	WHEEL	ROUE	TIEFEN	RUEDA	ANSAMBLUROATA
2	R17815720	SUPPORTO SOSTEGNO	SUPPORT SEALING	SUPPORT ETANCHEITE	HALTERUNG DICHTUNGS	SOPORTE AISLADOR	ANS.SUPPORT SUSTINERE
3	R17810440	PERNO ZN	PIN ZN	PIVOT ZN	BOLZEN ZN	PERNO ZN	BOLT ZN
4	F02200507	SPINA SCATTO D. 9 B/83 ZN	SNAP PIN D 9 B/83	FICHE A DETENTE D 9 B/83	EINRASTSTIFT D 9 B/83	CLAVIJA DE MUELLE D 9 B/83	STIFT RESORT D 9 ZB B/83
5	R17811170	SCONTRO PER TUBO 100	STRIKER PLATE 100	BUTEE 100	ANSCHLAG 100	ELEMENTO DE EMPALME 100	BRIDAFIXARE TEAVA 100
6	F01020343	VITE M24X 3X 80 U5737 10.9 ZB	BOLT M24X 3X 80 U5737 10.9 ZB	VIS M24X 3X 80 U5737 10.9 ZB	SCHR.M24X 3X 80 U5737 10.9 ZB	TORN.M24X 3X 80 U5737 10.9 ZB	SUR. M24X 3X 80 U5737 10.9 ZB
7	G18701590	RONDELLA 25X35X2,5 ZB	WASHER 25x35x2,5 ZB	RONDELLE 25 x 35 x2,5 ZB	UNTERLEGSCHIEBE 25 x 35 x2,5	ARANDELA 25 x 35 x2,5 ZB	SAIBA 25X35X2,5 ZB
8	F01230144	DADO M24X 3 D982 8 ZN	SELF-LOCKING NUT NORM.24 ZB	ECROU AUTOB.NORM.24 ZB	SELBSTSPERR. MUTTER NORM.24 ZB	TUERCA AUTOB. NORM.24 ZB	PIUL.M24X 3 D982 8 ZN

BANDINELLA MECCANICA

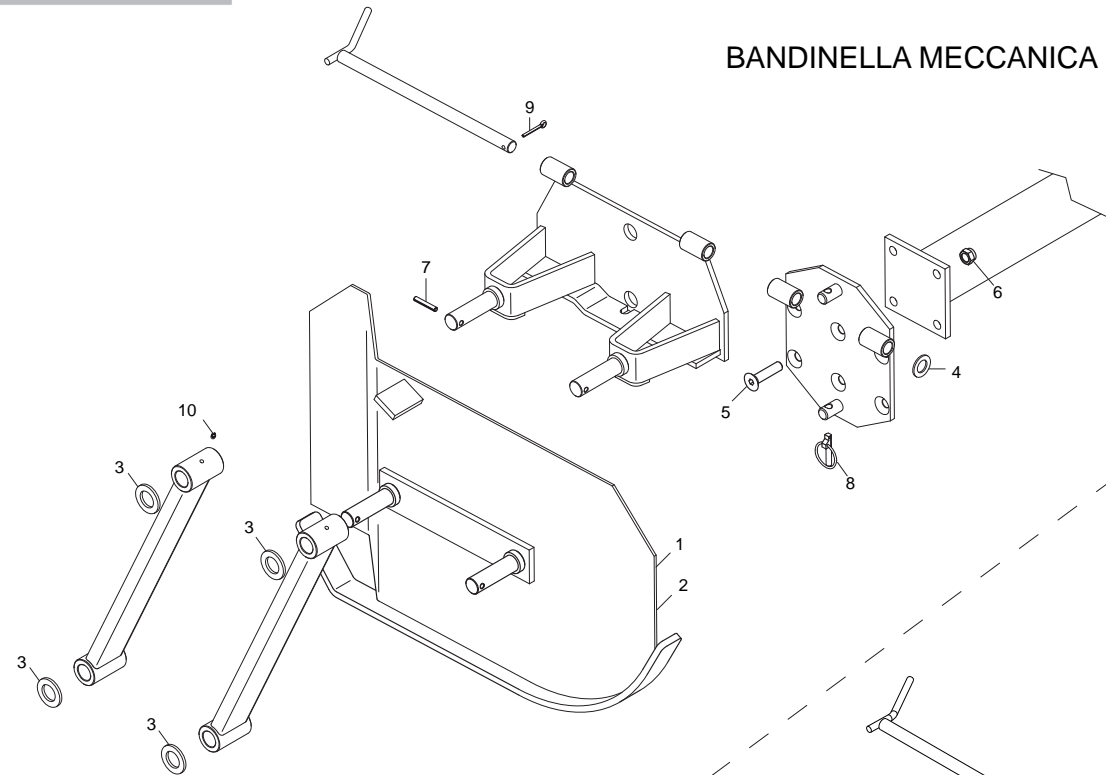

BANDINELLA IDRAULICA

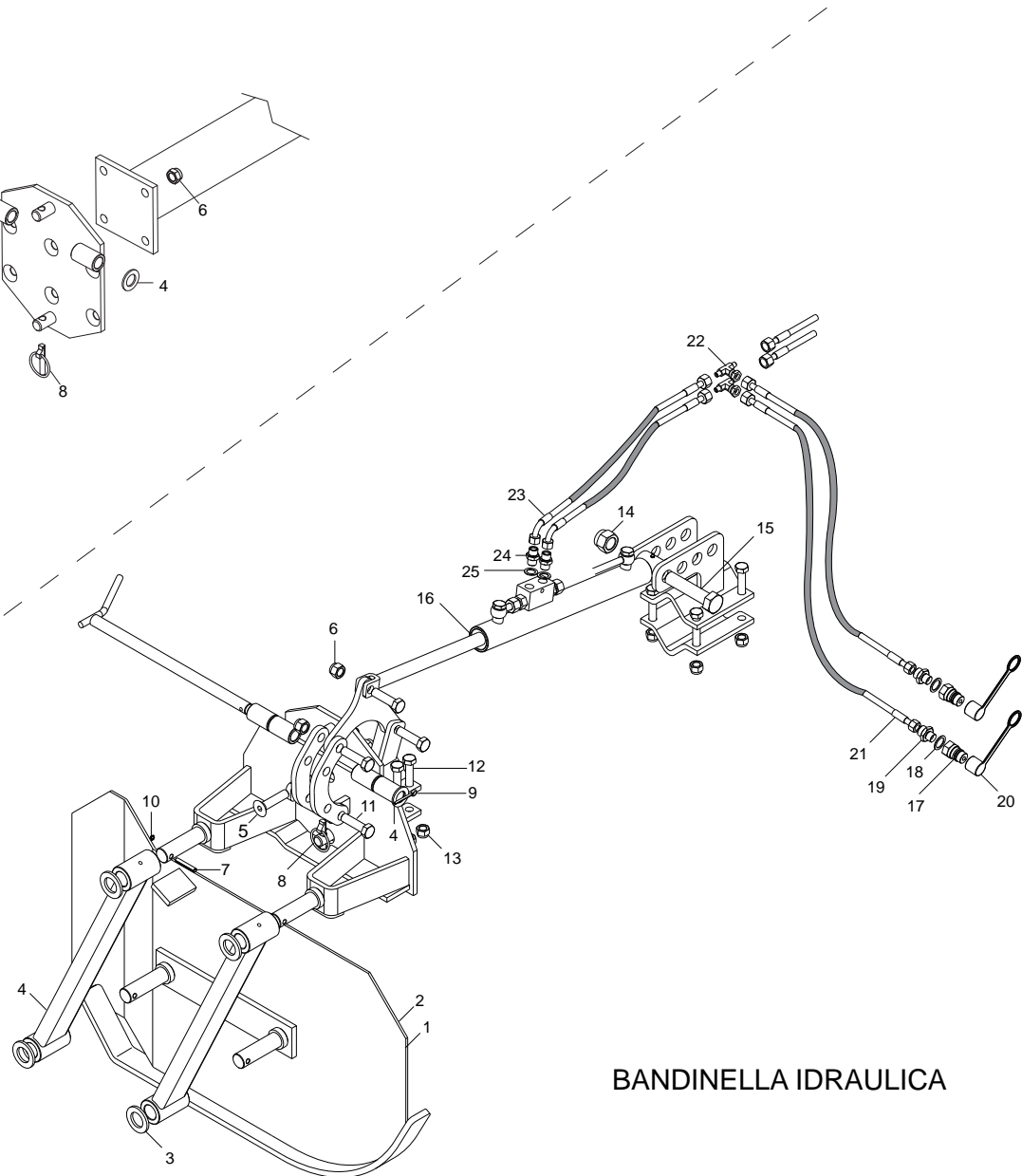

BANDINELLA LATERALE MECCANICA E IDRAULICA

TAV. 080

Pos.	Cod.	Descrizione	Description	Description	Benennung	Descrpcion	Descriere
1	R17811821	BANDELLA DX	PROTECTION DX	PROTECTIONDX	SCHUTZ DX	PROTECCIONDX	ANSAMBLU PROTECTIE DX
2	R17811831	BANDELLA SX	PROTECTION SX	PROTECTION SX	SCHUTZ SX	PROTECCION SX	ANSAMBLU PROTECTIE SX
3	G18700570	RONDELLA 20X54X6	WASHER 20X54X6	RONDELLE 20X54X6	SCHEIBE 20X54X6	ARANDELA 20X54X6	SAIBA 20X54X6
4	F01410135	ROS.M22 23X 39X 3 U6592 ZG	PLANE WASHER D.22	BAGUE D.22	SCHEIBE D.22	ARANDELA D.22	SAIBA PLANA D.22 UNI 6592 ZB
5	F01030152	VITE M16X 2X70 U5933 8.8 ZN	BOLT M16X2X70 U5933 8.8 ZB	VIS M16X2X70 U5933 8.8 ZB	SCHRAUBE M16X2X70 U593308.8 ZN	TORNILLO M16X2X70 U5933 8.8 ZB	SUR.M16X2X70 U5933 8.8 ZB
6	F01230085	DADO M16X 2 D982 8 ZB	NUT M16X 2 D982 8 ZB	ECROU M16X 2 D982 8 ZB	MUTT.M16X 2 D982 8 ZB	TUER.M16X 2 D982 8 ZB	PIUL.M16X 2 D982 8 ZB
7	F02100144	SPINA E.P. 8X 50 U6873 C70 BR	ELASTIC PIN 8X50 1481	GOUJON ELASTIQUE 8X50 1481	SPANNHUELSE 8X50 1481	ESPINA ELASTICA 8X50 1481	STIFT ELASTIC 8X50 DIN 1481
8	F02200507	SPINA SCATTO D. 9 B/83 ZN	SNAP PIN D 9 B/83	FICHE A DETENTE D 9 B/83	EINRASTSTIFT D 9 B/83	CLAVIJA DE MUELLE D 9 B/83	STIFT RESORT D 9 B B/83
9	F02200229	COPIGLIA 5X 45 U1336 ZN	SPLIT PIN 5 X45 1336 GALVAN.	GOUPILLE 5 X45 1336 ZN	SPLINT 5 X45 1336 ZN	PASADOR 5 X45 1336 ZN	SPLINT 5 X45 1336 ZB
10	F01100048	INGM 8X1,25 7663A9SMNPB28 ZG	SPHERE NIPPLE M8X 1,25 A	GRAISSEUR A BILLES M8 X 1-25 A	KUGELFETTBSCHSE M8 X 1-25 A	ENGRAS. DE ESFERAS M8 X 1-25 A	INGRANS. SFERIC M8 X 1,25 A ZB
11	F01020258	VITE M16X 2X 65 U5737 8.8 ZN	BOLT 16X65 5737 8.G GALVANIZED	VIS 16X65 5737 8.G ZN	SCHRAUBE 16X65 5737 8.G ZN	TORNILLO 16X65 5737 8.G ZN	SURUB M16X 2X 65 U5737 8.8 ZB
12	F01020205	VITE M14X2 X 65 5737 8.8 ZG	BOLTM 14X65	VISM 14X65	SCHRAUBE M 14X65	TORNILLO M 14X65	VITE M14X2 X 65 5737 8.8 ZB
13	F01230073	PIULITA AUT.A M14X2 D982 8G Z	SELF LOCKING NUT M14X2	ECROU AUTOBL. M14X2	SELBSTSP.MUTT. M14X2	DADO AUTOBL. M14X2	PIULITA AUT.A M14X2 D982 8G Z
14	F01230144	DADO M24X 3 D982 8 ZN	SELF-LOCKING NUT NORM.24 ZB	ECROU AUTOB.NORM.24 ZB	SELBSTSPERR. MUTTER NORM.24 ZB	TUERCA AUTOB. NORM.24 ZB	PIUL.M24X 3 D982 8 ZN
15	F01020348	VIT.M24X 3X140 U5737 8.8 ZN	BOLT M24X 3X140 U5737 8.8 ZB	VIS M24X 3X140 U5737 8.8 ZB	SCHR.M24X 3X140 U5737 8.8 ZB	TORN.M24X 3X140 U5737 8.8 ZB	SUR. M24X 3X140 U5737 8.8 ZB
16	R17841540	CILINDRO BANDINELA HIDRO	CYLINDER	CYLINDRE	ZYLINDER	CILINDRO	CILINDRU BANDINELA HIDRAULICA
17	F03150335	INNESTO RAP.MASCH.1/2A VALV.	QUICK CONNECT MALE CONE 1/2 CO	CONNEXION RAPIDE MALE CONE 1/2	SCHNELLKUPPLUNG GEWINDE KONISC	ACOPLAMIENTO RAPIDO MACHO CONO	CONECTARE RAPIDA TATA.CU 1/2
18	F03151237	RONDELLA RAME 21X27X1,5 -1/2"	1/2 COPPER WASHER	RONDELLE CUIVRE 1/2	UNTERLEGSCHIEBE KUPFER 1/2	ARANDELA COBRE 1/2	SAIBA RAME 1/2
19	F03150211	NIPPLO MM CIL-CIL 1/2-1/4 ZN	NIPLE 1/4-1/2	NIPLE 1/4-1/2	NIPLE 1/4-1/2	NIPLE 1/4-1/2	NIPLU 1/4-1/2
20	F05150325	CAPPUCCIO PROT.INNESTO RAP.1/2	COVER 1/2	COUVERCLE 1/2	DECKEL 1/2	TAPA 1/2	GLUGACONECTARE 1/2
21	R17817920	TUBO 1/4 FF L=2000	PIPE 1/4 FF L=2000	TUBE 1/4 FF L=2000	ROHR 1/4 FF L=2000	TUBO 1/4 FF L=2000	TUB 1/4 FF L=2000
22	F03151219	RACCORDO -T- MASCHIO 1/4 ZN	MALE T-UNION 1/4 ZINC.	RACCORD -T- MALE 1/4 ZING.	ANSCHLUSSTsCK -T- GEWINDE 1/4	UNIN -T- MACHO 1/4 CINC. R	ACORD -T- TATA 1/4 ZINC. R
23	G15210551	TUBO 1/4R2 C-F L.2750 LM	PIPE 1/4R1 C-F L.2750 LM	TUBE 1/4R1 C-F L. 2750 LM	ROHR 1/4R1 C-F L.2750 LM	TUBO 1/4R1 C-F L.2750 LM	TUB 1/4R2 C-F L.2750 LM
24	F03150310	NIPPLO MM CIL-CIL 3/8-1/4 ZN	NIPPLE GALV.CYL.MALE 3/8-1/4 ZN	NIPPLE MALE CYL.3/8-1/4 ZN	NIPPELZYL.3/8-1/4 ZN	NIPLE MACHO CIL.3/8-1/4 ZN	NIPLU TATA CIL.3/8-1/4 ZN
25	F03151240	RONDELLA RAME 3/8	3/8 COPPER WASHER	RONDELLE CUIVRE 3/8	UNTERLEGSCHIEBE KUPFER 3/8	ARANDELA COBRE 3/8	SAIBA RAME 3/8
26	F03100383	GUAINATELATA D=65 L=1750	SHEATH D=65 L=1750	GAINÉ D=65 L=1750	KABEL D=65 L=1750	VAINA D=65 L=1750	PROTECTIE TEXTILA D=65 L=1750

TAV. 090

MOD. 2007-2008

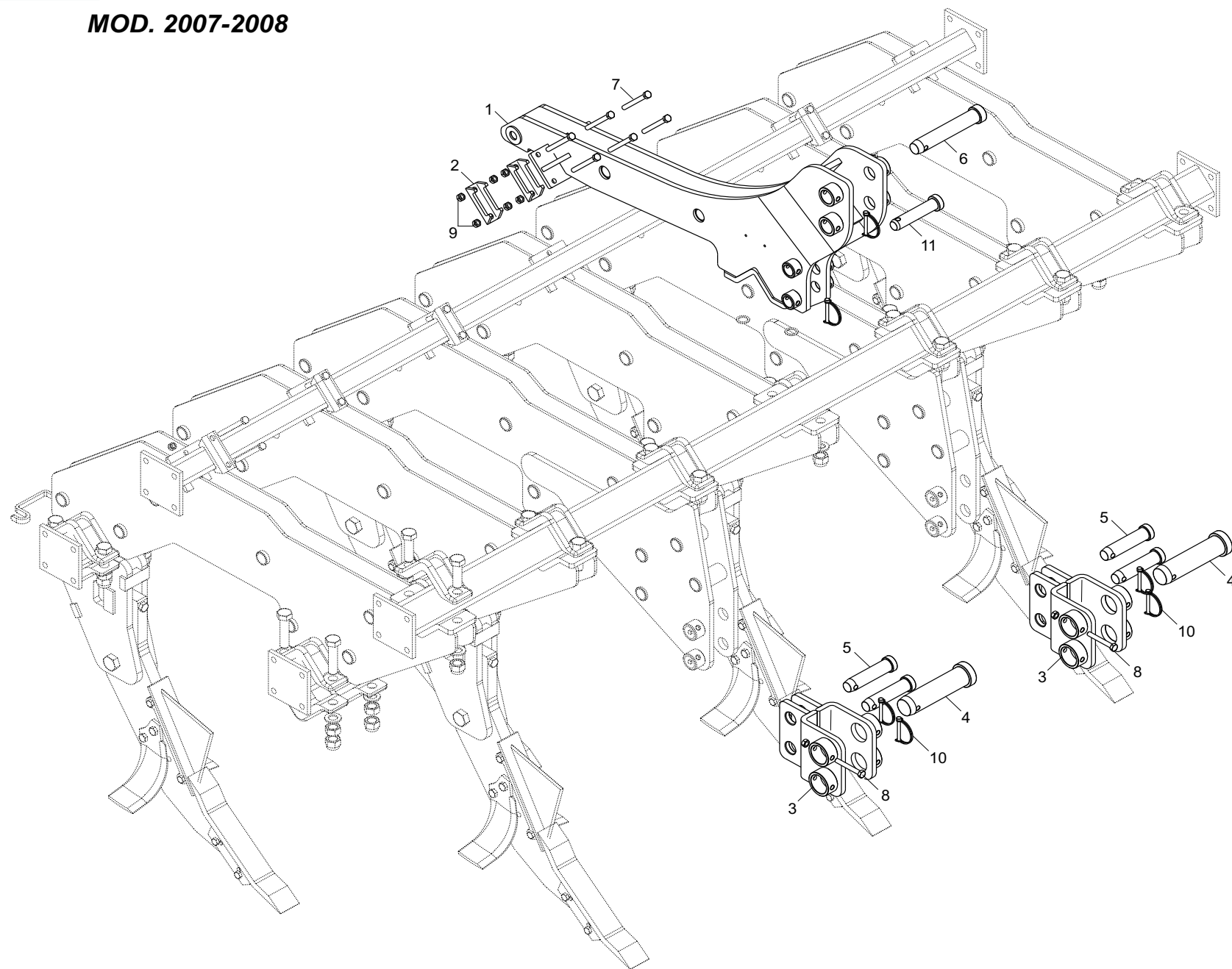

KIT "III" E "IV" CATEGORIA MOD. 2007-2008
TAV. 090

Pos.	Cod.	Descrizione	Description	Description	Benennung	Descripcion	Descriere
1	R17817481	ASS.ATTACC. 3-4 CATEG.	3-4 POINT LINKAGE FRAME	ATTELAGE UNIVERSEL 3-4 POINTS	3-4 PUNKT ANSCHLUSS HALTERUNG	ENGANCHE DE 3-4 PUNTOS	ANS.ATASARE 3-4 CATEG.
2	G16740160	SCONTRO A U SP.8 2F13.83	U-SHAPED STOP TEETH B343SP.8	BUTEE EN U SP.8 2F13.83	U-ANSCHLAG SP.8 2F13.83	DIENTE DE PARADAA U ESP.8	BRIDA U SP.8 2F13.83
3	R17812380	ATTACCO 1-2 PUNTO	1-2 POINT COUPLING	FIXATION 1-2 POINT	KUPPLUNG 1-2 PUNKT	CONEXIN 1-2 PUNTO	ANS. PRINDERE 1-2 PUNCTE
4	R17812390	SPINA GASPARDO 56X190 ZB	GASPARDO PIN 56X190 ZB	BROCHE GASPARDO 56X190 ZB	STIFT GASPARDO 56X190 ZB	CLAVIJA GASPARDO 56X190 ZB	STIFT GASPARDO 56X190 ZB
5	F20100112	PERNO D36 L128 C43 ZN	GASPARDO PIN 36X134 ZG	BROCHE GASPARDO 36X134 ZG	STIFT GASPARDO 36X134 ZG	CLAVIJA GASPARDO 36X134 ZG	STIFT GASPARDO 36X134 ZB
6	R17812440	SPINA GASPARDO 39X200 ZB	GASPARDO PIN 39X200 ZB	BROCHE GASPARDO 39X200 ZB	STIFT GASPARDO 39X200 ZB	CLAVIJA GASPARDO 39X200 ZB	STIFT GASPARDO 39X200 ZB
7	F01020174	VITE M12X1,75X120 5737 8.8 ZN	BOLT 12X120 5737 8.8 GALVANIZ.	VIS 12X120 5737 8.8 ZN	SCHRAUBE 12X120 5737 8.8 ZN	TORNILLO 12X120 5737 8.8 ZN	SUR. M12X1,75X120 5737 8.8 ZB
8	F01020168	VITE M12X1,75X90 5737 8.8 ZN	BOLT 12X90 5737 8.8 GALVANIZED	VIS 12X90 5737 8.8 ZN	SCHRAUBE 12X90 5737 8.8 ZN	TORNILLO 12X90 5737 8.8 ZN	SUR. M12X1,75X90 5737 8.8 ZN
9	F01230059	DADO M12X1,75 D982 8 ZB	NUT M12X1,75 D982 8 ZB	ECRO.M12X1,75 D982 8 ZB	MUTT.M12X1,75 D982 8 ZB	TUER.M12X1,75 D982 8 ZB	PIUL.M12X1,75 D982 8 ZB
10	F02200584	SPINA SICUR. D. 12X70 ZN	GALVAN. SAFETY PIN D.12X70	GOUPILLE DE S+CURIT+ D.12X70 Z	SCHERSTIFT D.12X70 ZN	PASADOR DE SEGURIDAD D 12X70 Z	STIFT DE SIGURANTA D.12X70 ZN
11	F20100101	PERNO D32 L128 C43 ZN	PIN GASPARDO 32X134 ZN	BROCHE GASPARDO 32X134 ZN	STIFT GASPARDO 32X134 ZN	CLAVIJA GASPARDO 32X134 ZN	STIFT GASPARDO 32X134 ZN

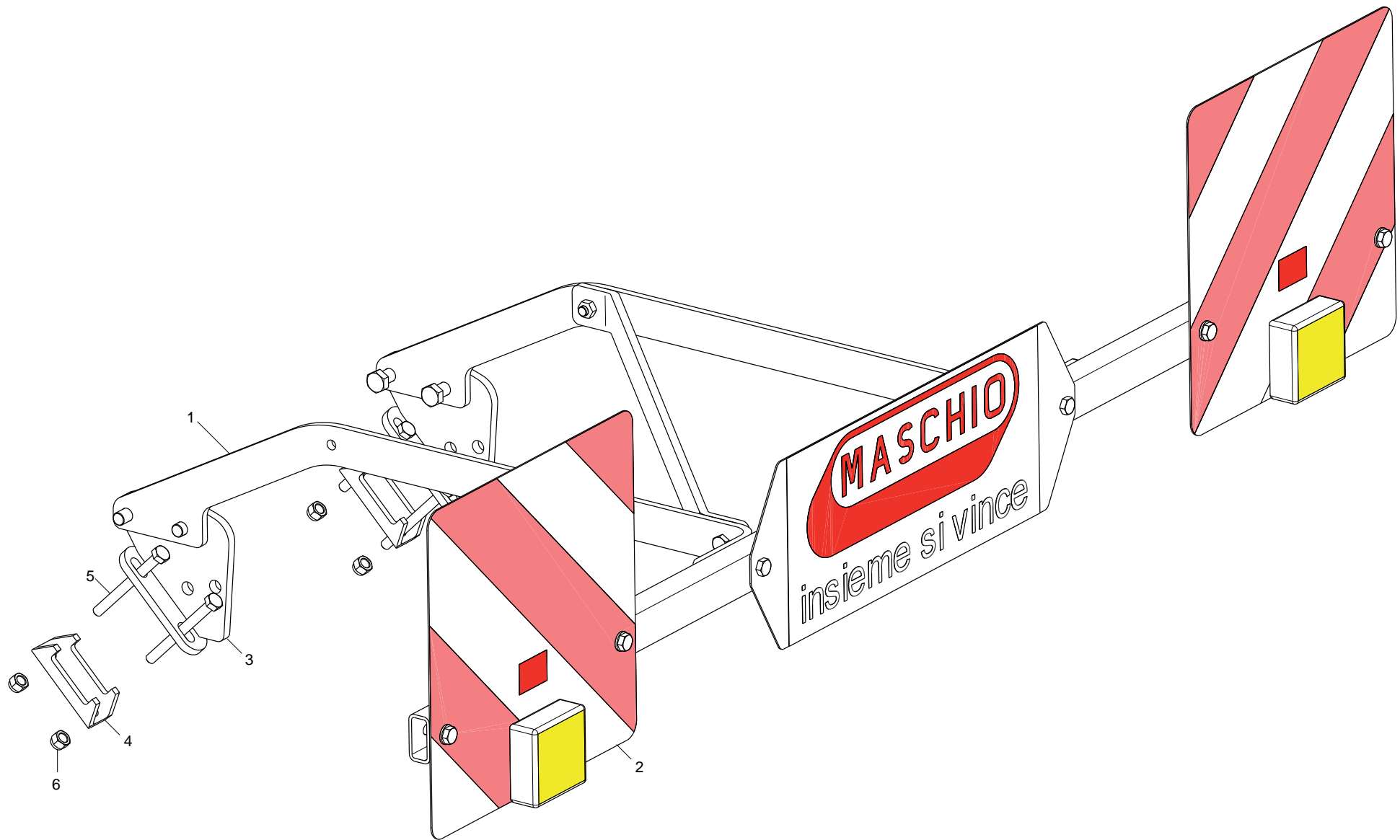

KIT LUCI**TAV. 100**

Pos.	Cod.	Descrizione	Description	Description	Benennung	Descripcion	Descriere
1	M12400957	FANALE KIT LUCI	LAMP KIT LIGHTS	FEU KIT ECLAIRAGE	LAMPENKIT LICHT	FAROL SET LUCES	FARURI PENTRU SET LUMINI
2	M12400956	KIT SUPPORTO BARRA LUCE	KIT SUPPORT	KIT SUPPORT	KIT HALTERUNG	KIT SOPORTE	KIT SUPORT BARA DE LUMINI
3	R17841000	ASSIEME ATTACCO	COUPLING	FIXATION	KUPPLUNG	CONEXIN	ANSAMBLU ATASARE
4	G16740160	SCONTRIO A U SP.8 2F13 83	U-SHAPED STOP TEETH B343SP.8	BUTEE EN U SP.8 2F13 83	U-ANSCHLAG SP.8 2F13 83	DIENTE DE PARADAA U ESP.8	BRIDA U SP.8 2F13 83
5	F01020174	VITE M12X1,75X120 5737 8.8 ZN	BOLT 12X120 5737 8.8 GALVANIZ.	VIS 12X120 5737 8.8 ZN	SCHRAUBE 12X120 5737 8.8 ZN	TORNILLO 12X120 5737 8.8 ZN	SUR. M12X1,75X120 5737 8.8 ZB
6	F01230059	DADO M12X1,75 D982 8 ZB	NUT M12X1,75 D982 8 ZB	ECRO. M12X1,75 D982 8 ZB	MUTT. M12X1,75 D982 8 ZB	TUER. M12X1,75 D982 8 ZB	PIUL. M12X1,75 D982 8 ZB

**USATE SEMPRE RICAMBI ORIGINALI
 ALWAYS USE ORIGINAL SPARE PARTS
 IMMER DIE ORIGINAL-ERSATZTEILE VERWENDEN
 EMPLOYEZ TOUJOURS LES PIECES DE RECHANGE ORIGINALES
 UTILIZAR SIEMPRE REPUESTOS ORIGINALES
 UTILIZAȚI ÎNTOTDEAUNA PIESE DE SCHIMB ORIGINALE**

MASCHIO GASPARDO

**Serviciu Asistenta Tehnica +40 752 30 70 43
 Piese de schimb +40 742 30 70 52**



MASCHIO GASPARDO

R19530770

R19530770

MASCHIOGASPARDO SpA

Sede legale e stabilimento produttivo

Via Marcello, 73 - 35011 Campodarsego (Padova) - Italy
 Tel. +39 049 9289810
 Fax +39 049 9289900
 Email: info@maschio.com
 www.maschionet.com

MASCHIO DEUTSCHLAND GMBH

Äußere Nürnberger Straße 5
 D - 91177 Thalmissing ng
 Deutschland
 Tel. +49 (0) 9173 79000
 Fax +49 (0) 9173 790079

MASCHIO FRANCE Sarl

1, Rue de Mérignan ZA
 F - 45240 La Ferte St. Aubin
 France
 Tel. +33 (0) 2.38.64.12.12
 Fax +33 (0) 2.38.64.66.79

MASCHIO IBERICA S.L.

Calle Cabernet, 10
 Poligono Industrial Clot de Moja
 Olerdola - 08734 Barcelona
 Tel. +34 93.81.99.058
 Fax +34 93.81.99.059

MASCHIO-GASPARDO USA Inc

120 North Scott Park Road
 Eldridge, IA 52748 - USA
 Ph. +1 563 2859937
 Fax +1 563 2859938
 e-mail: info@maschio.us

MASCHIOGASPARDO SpA

Stabilimento produttivo

Via Mussons, 7 - 33075
 Morsano al Tagliamento (PN) - Italy
 Tel. +39 0434 695410
 Fax +39 0434 695425
 Email: info@gaspardo.it

ООО МАСКИО-ГАСПАРДО РУССИЯ

404126, Россия, Волгоградская область,
 г.Волжский, ул.Пущина, 117 *6*.
 Тел.: +78443525065
 факс: +78443525064
 e-mail: info@maschio.ru
 http://www.maschionet.com

MASCHIO GASPARDO ROMANIA SRL

Strada Înfrățirii, Nr. 155
 315100 Chișineu - Criș
 Tel. +40 257 30 70 30
 Fax +40 257 30 70 40
 e-mail: info@maschio.com
 http://www.maschio.com

MASCHIO MIDDLE EAST

P.O. Box 922388
 Amman, 11192 Jordan
 Tel. 962 605511384
 Fax 962 6 5538398
 e-mail: tahaeng@nets.com.jo

GASPARDO-MASCHIO TURCHIA

MASCHIO-GASPARDO CANADA Inc
MASCHIO-GASPARDO CINA
MASCHIO-GASPARDO POLAND
MASCHIO-GASPARDO UCRAINA
GASPARDO BIELORUSSIA
MASCHIO-GASPARDO KOREA