

# MASCHIO GASPARDO

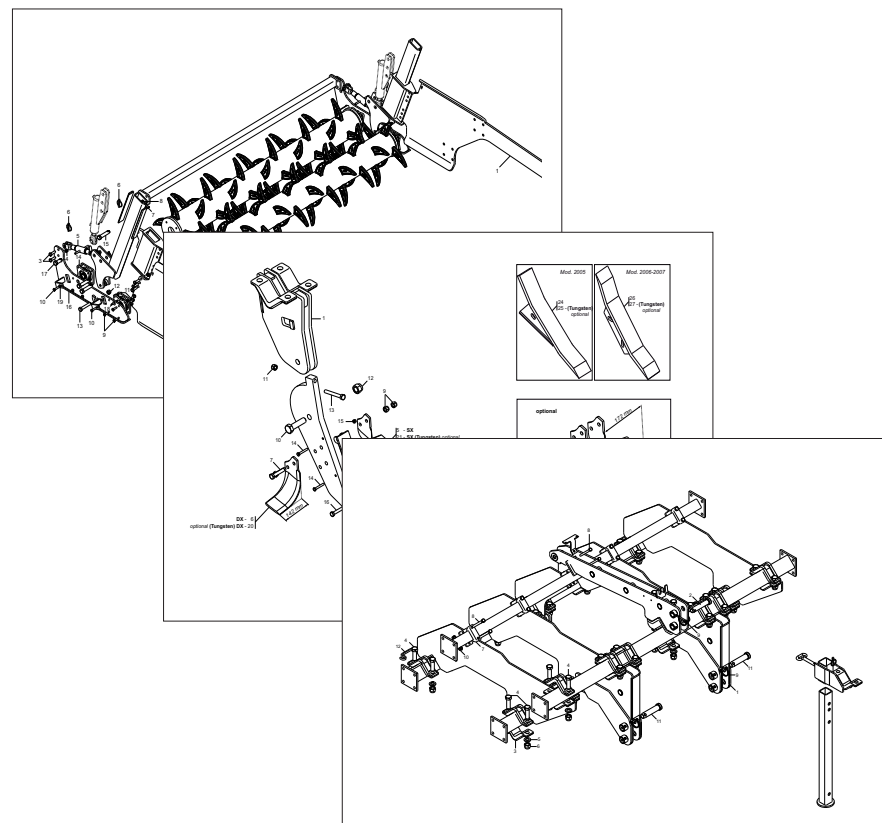

# ATTILA

**Cod: R19530770 03 / 2009**

- \*) Valido per Paesi UE
- \*) Valid for EU member countries
- \*) Gilt für EU-Mitgliedsländer
- \*) Valable dans le Pays UE
- \*) Válido para Países UE
- \*) Valabil pentru tarile UE

**IT** PARTI DI RICAMBIO  
**EN** SPARE PARTS  
**DE** ERSATZTEILE  
**FR** PIÈCES DÉTACHÉES  
**ES** PIEZAS DE REPUESTO  
**RO** PIESE DE SCHIMB

## PARTI DI RICAMBIO

Le ordinazioni delle parti di ricambio vanno fatte presso i nostri concessionari di zona e devono essere sempre corredate dalle seguenti indicazioni:

- **Tipo, modello e numero di matricola dell'attrezzatura.** Tali dati sono stampigliati nell'apposita targhetta di cui è dotata ogni attrezzatura.
- **Numero di codice della parte richiesta** rilevabile dal catalogo ricambi.
- **Descrizione del particolare e quantità richiesta.**
- **Numero della tavola.**
- **Mezzo di trasporto.** Nel caso questa voce non sia specificata, la Ditta Costruttrice, pur dedicando a questo servizio una particolare cura, non risponde di eventuali ritardi di spedizione dovuti a cause di forza maggiore.

Le spese di trasporto si intendono sempre a carico del destinatario. La merce viaggia a rischio e pericolo del committente anche se venduta franco destino.

**NOTA:** Il termine **(Dx) Destro** o **(Sx) Sinistro** della macchina o di parti di essa, è inteso guardando la macchina dalla parte posteriore. Le eccezioni saranno indicate.

## SPARE PARTS

*Orders must be transmitted through our area dealers and should always include the following indications:*

- **Type, model and serial number of the machine.** *These data are punched on the data plate with which every implement is equipped.*
- **Code number of the required spare part.** *This will be found in the spare parts catalogue.*
- **Description of the part and required quantity.**
- **Table number.**
- **Means of dispatch.** *If this item is not indicated, the Manufacturer, while dedicating particular care to this service, shall not be held responsible for delays in delivery caused by cases of force majeure.*

*Transport expenses shall always be at the consignee's charge. The goods travel at the purchaser's risk and peril even when sold ex destination.*

**NOTE:** *The symbols (Dx) right and (Sx) left, concerning the machine or single parts of it, are referred, as in the figure, to a rear view of them. Exceptions will be indicated.*

## ERSATZTEILE

Die Bestellungen müssen bei unseren Gebietshändler angegeben werden. Bei der Bestellung sind stets die folgenden Angaben zu machen:

- **Typ, Modell und Serien-Nummer des Geräts.** Diese Daten stehen auf dem Typenschild, mit dem jedes Gerät versehen ist.
- **Artikel Nr. der erforderlichen Ersatzteile.** Diese stehen im Ersatzteil-Katalog.
- **Beschreibung des Ersatzteils und die erforderliche Stückzahl.**
- **Tafelnummer.**
- **Versandmittel.** Wenn dieser Punkt nicht spezifiziert wird, haftet die Herstellerfirma nicht für etwaigen Lieferverzug aufgrund höherer Gewalt, auch wenn er diesen Service besonders aufmerksam abwickelt.

Die Frachtkosten gehen dagegen immer zu Lasten des Empfängers. Die Ware reist auf Gefahr und Risiko des Auftraggebers, auch wenn frei Haus Verkauft vereinbart worden ist.

**N.B.:** Die Merkzeichen **(Dx) rechts** und **(Sx) links** betreffen eine rückwärtige Aussicht der Maschine oder Teile von ihr (siehe Bild). Ausnahmen werden gezeigt.

## PIECES DÉTACHÉES

*Les ordres doivent être effectués auprès de nos concessionaires de zone en précisant les indications suivantes:*

- **Type, modèle et numéro de série de la machine.** *Ces données sont gravées sur la plaque d'identification de chaque outil.*
  - **Numéro de code de la pièce détachée** *indiqué sur le catalogue des pièces détachées.*
  - **Description de la pièce et quantité requise.**
  - **Numéro de plan.**
  - **Moyen d'expédition.** *Si cette rubrique n'est pas indiquée, le Constructeur, bien que soucieux de ce service, ne répond pas des retards d'expédition pour des causes de force majeure. Les frais de transport sont toujours à la charge du destinataire. La marchandise voyage aux risques et périls de l'acheteur même si vendue franco de port.*
- N.B.:** *Les références (Dx) droit et (Sx) gauche de la machine ou des parties de la même, est entendue, comme de la figure, en regardant la machine de derriere dans le sens de marche.*

## RESPUESTOS

Los pedidos han de efectuarse en nuestros consesionarios de zona y deben incluir siempre las siguientes indicaciones:

- **Tipo, modelo y número de matrícula del equipo.** Dichos datos están impresos en la relativa placa presente en el equipo.
- **Número de código de la parte requerida** presente en el catálogo respuestas.
- **Descripción de la pieza y cantidad requerida.**
- **Numero de ilustración.**
- **Medio de transporte.** En caso que este ítem no esté especificado, el Fabricante, aún prestando la debidas consideraciones para este aspecto, no responde por eventuales retardos de env'o debidos a causas de fuerza mayor.

Los gastos de transporte se consideran siempre a cargo del destinatario. La mercadería viaja bajo riesgo y peligro del comprador, incluso cuando se vende franco destino.

**N.B.:** La refencia **(Dx) derecha** o **(Sx) izquierda** de la máquina o de sus componentes, se entien-de, como en la figura, mirando la máquina por la parte trasera. Se indicarán las excepciones.

## PIESE DE SCHIMB

*Comandarea pieselor de schimb se va face prin intermediul concesionarilor din zonă și trebuie să fie întotdeauna însoțite de următoarele date:*

- **Tipul, modelul și numărul de matricolă al utilajului.** *Aceste date se găsesc pe plăcuța de identificare a fiecărui utilaj.*
- **Numărul de cod al piesei de schimb cerute,** *care se găsește în manual.*
- **Descrierea piesei de schimb și cantitatea cerută.**
- **Numărul desenului în care se găsește piesa.**
- **Mijloc de transport.** *În cazul în care acesta nu este specificat, Firma Constructoare poate avea un regim special, nu răspunde de eventualele întârzieri de expediere datorate unor cauze de forță majoră.*

*Cheltuielile de transport sunt suportate de destinatar. Marfa este transportată pe riscul celui care efectuează comanda, chiar dacă marfa este vândută în condiții franco-destinatar.*

**NOTA:** *Termenul (Dx) Dreapta sau (Sx) Stânga a utilajului sau a părților acestuia, este privind utilajul din partea posterioară. Excepțiile vor fi indicate.*

<b>Nr. Tav.</b>	<b>Descrizione</b>	<b>Pag.</b>	<b>Nr. Tav.</b>	<b>Description</b>	<b>Pag.</b>
TAV. 010	Telaio	4	TAV. 010	Cadre	4
TAV. 020	Elemento operatore	6	TAV. 020	Element operateur	6
TAV. 030	Doppio rullo posteriore meccanico	8	TAV. 030	Double rouleau posterieur mecanique	8
TAV. 040	Doppio rullo posteriore oleodinamico	10	TAV. 040	Double rouleau posterieur hydraulique	10
TAV. 050	Impianto oleodinamico	12	TAV. 050	Installation hydraulique	12
TAV. 060	Dischi posteriori	14	TAV. 060	Disque posterieur	14
TAV. 070	Ruote di profondità	16	TAV. 070	Roue de profondeur	16
TAV. 080	Bandinella laterale meccanica	18	TAV. 080	Mecanique bande	18
TAV. 090	Kit luci	20	TAV. 090	Kit d'eclairage	20

<b>Nr. Tav.</b>	<b>Description</b>	<b>Pag.</b>	<b>Nr. Tav.</b>	<b>Descripcion</b>	<b>Pag.</b>
TAV. 010	Frame	4	TAV. 010	Bastidor	4
TAV. 020	Element operator	6	TAV. 020	Elemento operadore	6
TAV. 030	Double rear roller mechanical	8	TAV. 030	Doble rollo posterior mecanico	8
TAV. 040	Hydraulic double rear roller	10	TAV. 040	Doble rollo posterior hidraulico	10
TAV. 050	Hydraulic plant	12	TAV. 050	Instalacion hidraulica	12
TAV. 060	Rear discs	14	TAV. 060	Discos trasero	14
TAV. 070	Depth wheel	16	TAV. 070	Rueda de profundidad	16
TAV. 080	Mechanical strip clod	18	TAV. 080	Bandas mecanica	18
TAV. 090	Lighting kit	20	TAV. 090	Kit de iluminacion	20

<b>Nr. Tav.</b>	<b>Beschreibung</b>	<b>Pag.</b>	<b>Nr. Tav.</b>	<b>Descriere</b>	<b>Pag.</b>
TAV. 010	Rahmen	4	TAV. 010	Cadru	4
TAV. 020	Elemente betreiber	6	TAV. 020	Element operator	6
TAV. 030	Doppelte Nachaufwalze Mechanische	8	TAV. 030	Rulou dublu posterior mecanic	8
TAV. 040	Hydraulischen Doppelte Nachaufwalze	10	TAV. 040	Rulou dublu posterior oleodinamic	10
TAV. 050	Hydraulischen Anzug	12	TAV. 050	Instalație oleodinamică	12
TAV. 060	Hinten Disc	14	TAV. 060	Discuri posteriore	14
TAV. 070	Block Tiefe	16	TAV. 070	Roată de adâncime	16
TAV. 080	Mechanische Streifen	18	TAV. 080	Limitator lateral de brazdă mecanic	18
TAV. 090	Lichter kit	20	TAV. 090	Kit lumini	20

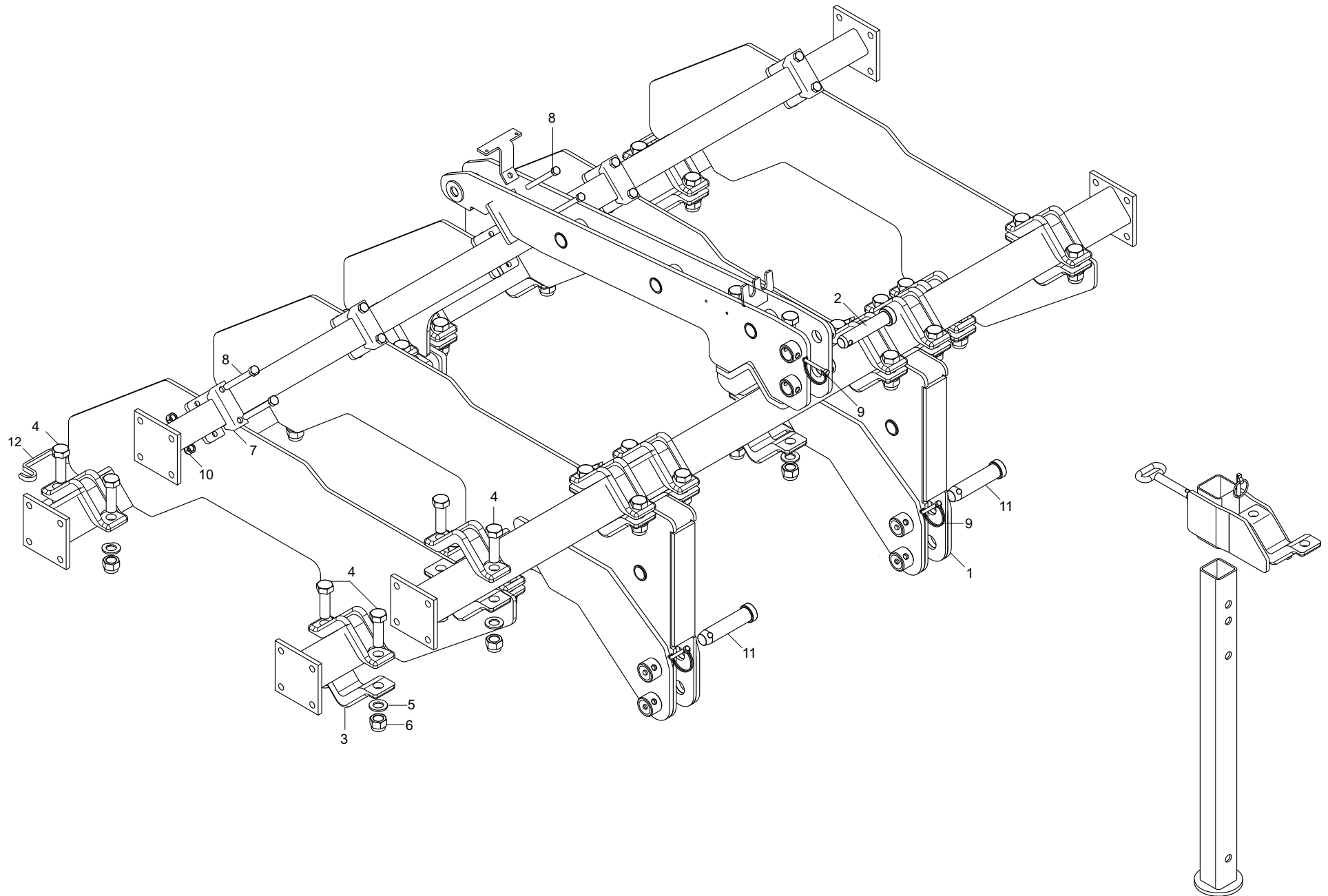

**TELAIO / FRAME / RAHMEN / CADRE / BASTIDOR / CADRU**

**TAV. 010**

Pos.	Cod.	Descrizione	Description	Description	Benennung	Descripcion	Descriere
1	R17813741	ASSIEME CENTRALE	FRAME SUPPORT CENTRAL	SUPPORT CH-SSIS	RAHMENHALTERUNG	SOPORTE BASTIDOR	ANSAMBLU CENTRAL
2	F20100101	PERNO D32 L128 C43 ZN	PIN GASPARDO 32X134 ZN	BROCHE GASPARDO 32X134 ZN	STIFT GASPARDO 32X134 ZN	CLAVIJA GASPARDO 32X134 ZN	STIFT GASPARDO 32X134 ZN
3	R17811170	SCONTRO PER TUBO 100	STRIKER PLATE 100	BUTEE 100	ANSCHLAG 100	ELEMENTO DE EMPALME 100	BRIDA FIXARE TEAVA 100
4	F01020343	VITE M24X 3X 80 U5737 10.9 ZD	BOLT M24X 3X 80 U5737 10.9 ZB	VIS M24X 3X 80 U5737 10.9 ZB	SCHR.M24X 3X 80 U5737 10.9 ZB	TORN.M24X 3X 80 U5737 10.9 ZB	SUR. M24X 3X 80 U5737 10.9 ZB
5	G18701590	RONDELLA 25X35X2,5 ZB	WASHER 25 x 35 x2,5 ZB	RONDELLE 25 x 35 x2,5 ZB	UNTERLEGSCHEIBE 25 x 35 x2,5	ARANDELA 25 x 35 x2,5 ZB	SAIBA 25X35X2,5 ZB
6	F01230144	DADO M24X 3 D982 8 ZN	SELF-LOCKING NUT NORM.24 ZB	ECROU AUTOB.NORM.24 ZB	SELBSTSPERR. MUTTER NORM.24 ZB	TUERCA AUTOB .NORM.24 ZB	PIUL.M24X 3 D982 8 ZN
7	G16740160	SCONTRO A U SP.8 2F13 83	U-SHAPED STOP TEETH B343SP.8	BUTEE EN U SP.8 2F13 83	U-ANSCHLAG SP.8 2F13 83	DIENTE DE PARADA A U ESP.8	BRIDA U SP.8 2F13 83
8	F01020174	VITE M12X1,75X120 5737 8.8 ZN	BOLT 12X120 5737 8.8 GALVANIZ.	VIS 12X120 5737 8.8 ZN	SCHRAUBE 12X120 5737 8.8 ZN	TORNILLO 12X120 5737 8.8 ZN	SUR. M12X1,75X120 5737 8.8 ZB
9	F02200584	SPINA SICUR. D. 12X70 ZN	GALVAN. SAFETY PIN D.12X70	GOUPILLE DE S+CURIT+ D.12X70 Z	SCHERSTIFT D.12X70 ZN	PASADOR DE SEGURIDAD D 12X70 Z	STIFT DE SIGURANTA D.12X70 ZN
10	F01230059	DADO M12X1,75 D982 8 ZB	NUT M12X1,75 D982 8 ZB	ECRO.M12X1,75 D982 8 ZB	MUTT.M12X1,75 D982 8 ZB	TUER.M12X1,75 D982 8 ZB	PIUL.M12X1,75 D982 8 ZB
11	F20100112	PERNO D36 L128 C43 ZN	GASPARDO PIN 36X134 ZG	BROCHE GASPARDO 36X134 ZG	STIFT GASPARDO 36X134 ZG	CLAVIJA GASPARDO 36X134 ZG	STIFT GASPARDO 36X134 ZB
12	R17813930	LAMA INTERPOSIZIONE SCONTRI	BLADE	LAME	MESSER	CUCHILLA	PLACA POZITIONARE BRIDA

TAV. 020

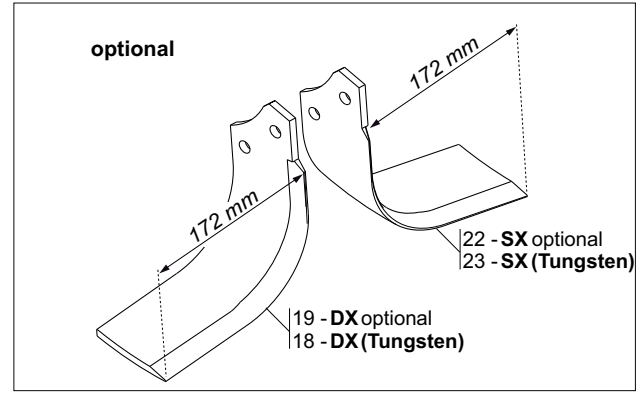
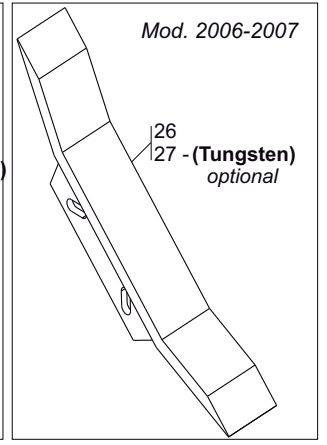
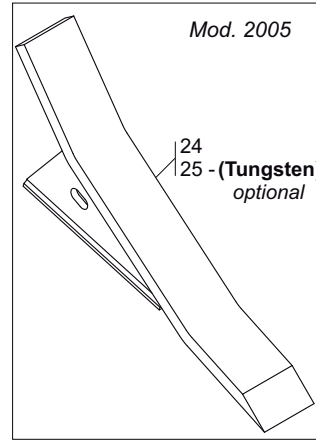
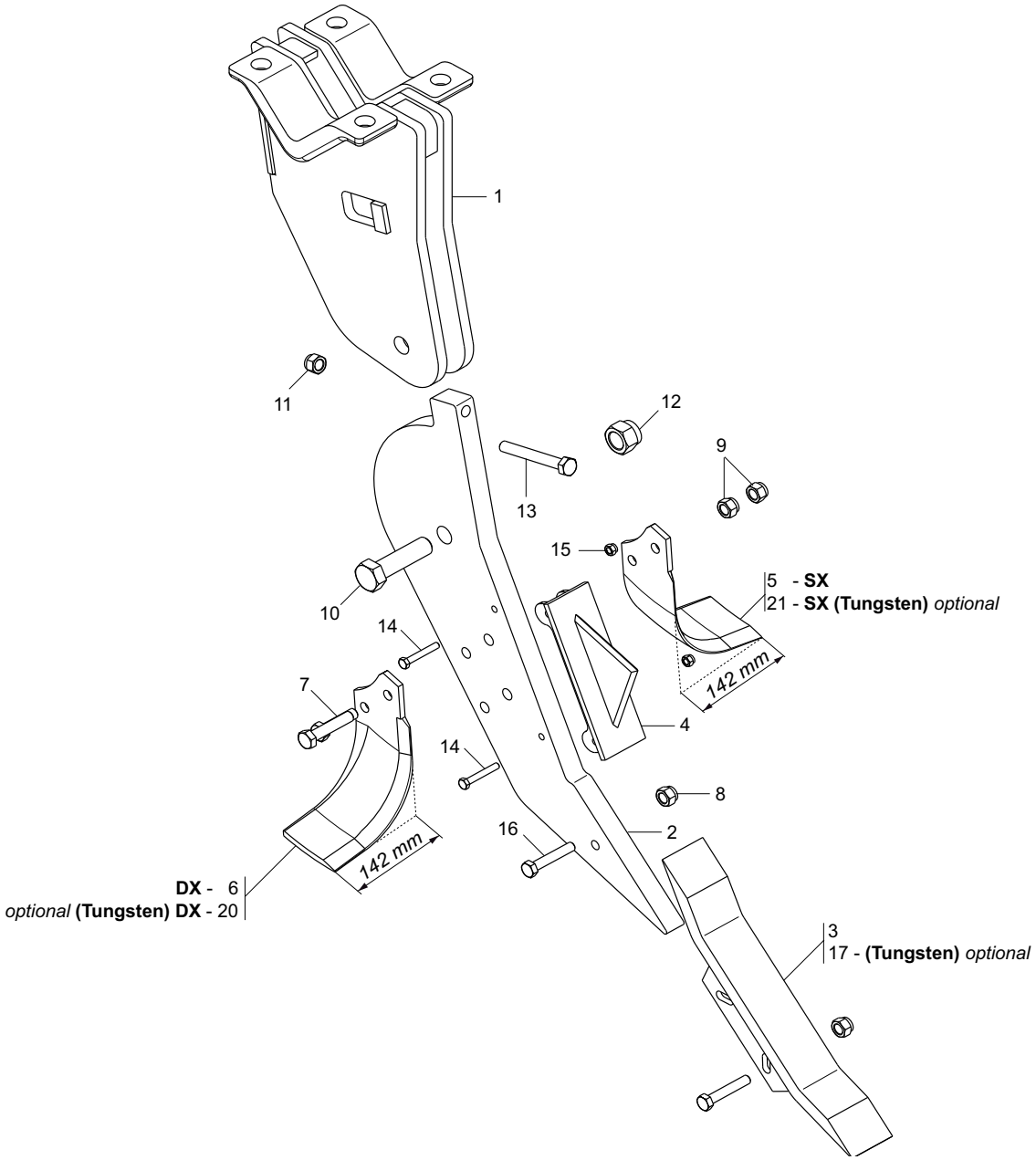

**ELEMENTO OPERATORE / ELEMENT OPERATOR / ELEMENTE BETREIBER / ELEMENT OPERATEUR /  
ELEMENTO OPERADORE / ELEMENT OPERATOR**

TAV. 020

Pos.	Cod.	Descrizione	Description	Description	Benennung	Descripcion	Descriere
1	R17820540	SUPPORTO PUNTALE	TIP	SUPPORT EMBOUT	MESSERHALTER	SOPORTE PUNTAL	ANS.SUPPORT VARF
2	R17820561	LAMA PUNTELO	PROP. BLADE	LAMA ETRESILLON	MESSER SUPORT	LAMA PUNTAL	LAMA PROPTITOR
3	R17820681	ASSIEME DENTE	POINT ATTILA-PIN RAPID-REVERS	ANS. DENT	ZINKEN	DIENTE ATTILA	ANSAMBLU DINTE ATTILA
4	R17820411	ASSIEME SUPORTO LAMA	ANS. SUPPORT BLADE	ASS. SUPPORT LAMA	MESSERHALTERUNG	ANS. CUCHILLA SOPORTE	ANSAMBLU LAMA SUPORT
5	M74100435	ZAPPA AD ELICA DESTRA S=10	RIGHT C BLADES (THICKNESS 10)	LAME HELICE DRT	RECHTES BOGENMESSER	AZADA HELICE DERECHA	SAPA ELICOIDALA DREAPTA
6	M74100436	ZAPPA AD ELICA SINISTRA S=10	LEFT C BLADES (THICKNESS 10)	LAME HELICE GCH	BOGENMESSER SX	AZADA HELICE SX	SAPA ELICOIDALA STANGA
7	F01020207	VITE M14X 2X 70 U5737 8.8 ZB	BOLT M 14X70	VIS M 14X70	SCHRAUBE M 14X70	TORNILLO M 14X70	SURUB M14X 2X 70 U5737 8.8 ZB
8	F01230059	DADO M12X1,75 D982 8 ZN	NUT M12X1,75 D982 8 ZB	ECRO.M12X1,75 D982 8 ZB	MUTT.M12X1,75 D982 8 ZB	TUER.M12X1,75 D982 8 ZB	PIUL.M12X1,75 D982 8 ZB
9	F01230073	DADO .A M14X2 D982 8G ZB	SELF LOCKING NUT M14X2	ECROU AUTOBL. M14X2	SELBSTSP.MUTT. M14X2	TUERCA AUTOBL. M14X2	PIULITA AUT.A M14X2 D982 8G Z
10	F01020344	VITE M24X100 5737 10.9 ZN	BOLT M24X3X100 U5737 10.9 ZD	VIS M24X100 5737 10.9 ZN	SCHRAUBE M24X100 5737 10.9 ZN	TORNILLO M24X100 5737 10.9 ZN	SURUB M24X100 5737 10.9 ZN
11	F01260046	DADO FLANG. M14 D6923 8.8 ZB	NUT M14 D6923 8.8 ZB	ECROU M14 D6923 8.8 ZB	MUTTER M14 D6923 8.8 ZB	TUERCA M14 D6923 8.8 ZB	PIULITA FLANG.M14 D6923 8.8 ZB
12	F01230144	DADO M24X 3 D982 8 ZB	NUT M24X 3 D982 8 ZB	ECROU M24X 3 D982 8 ZB	MUTTER M24X 3 D982 8 ZB	TUERCA M24X 3 D982 8 ZB	PIULITA M24X 3 D982 8 ZB
13	F01020212	VITE M14X 2X 90 U5737 8.8 ZB	BOLT M14X 2X 90 U5737 8.8 ZB	VIS M14X 2X 90 U5737 8.8 ZB	SCHARUBE M14X2X 90 U5737 8.8ZB	TORNILLO M14X 2X 90 U5737 8.8	SURUB M14X 2X 90 U5737 8.8 ZB
14	F01020077	VITE M 8X1,25X60 U5737 8.8 ZG	BOLT M8X1,25X60 U5737	VIS M8X1,25X60 U5737	SCHRAUBE M 8X60 U5737	TORNILLO M 8X60 U5737	SURUBUR M8X1,25X60 U5737
15	F01230034	DADO M 8X1,25 D982 8	SELF LOCKING NUT M8X1,25	ECROU AUTOBL. M8X1,25	SELBSTSP.MUTT. M8X1,25	DADO AUTOBL. M8X1,25	PIULITA AUT.M8X1,25 D982 8G ZB
16	F01020162	VITE M12X1,75X65 U5737 8.8 ZN	BOLT M12X1,75X65 U5737 8.8 ZG	VIS M12X1,75X65 U5737 8.8 ZG	SCHRAUBE M12X1,75X65 U5737 8.8	TORNILLO M12X1,75X65 U5737 8.8	SUR. M12X1,75X65 U5737 8.8 ZB
17	R17820731	ASS. DENTE TG	ANS. TOOTH TG	ANS. DENT TG	ZINKEN TG	DIENTE TG ATTILA	ANSAMBLU DINTE TG
18	R17820880	ZAPPA ELICA DROIT TG P30	RIGHT HELICOIDAL BLADE TG P30	LAME HELICE DRT TG P30	BOGENMESSER SX TG P30	AZADA DX TG P30	SAPA DX TG P30
19	R17820830	ZAPPA AD ELICE DX P30	HOE DX P30	LAME DX P30	HACKE DX P30	AZADA ELIC. DX P30	SAPA ELICOIDALA DX P30
20	R17820860	ZAPPA AD ELICA DESTRA TG	RIGHT C BLADES TG	LAME HELICE DRT	RECHTES BOGENMESSER TG	AZADA HELICE DERECHA TG	SAPA ELICOIDALA DREAPTA TG
21	R17820870	ZAPPA AD ELICA SX TUNGSTEN	LEFT HELICOIDAL BLADE TUNGSTEN	LAME HELICE B-C-SC GCH TG	LINKES BOGENMESSER TG	AZADA HELICE IZQUIERDA TUNGSTE	SAPA ELICE SX TUNGSTEN
22	R17820820	ZAPPA ELICA SX	LEFT HELICOIDAL BLADE	LAME HELICE B-C-SC GCH	BOGENMESSER	AZADA SX P30	SAPA SX P30
23	R17820890	ZAPPA ELICA SX TG P30	LEFT HELICOIDAL BLADE TG P30	LAME HELICE GCH TG P30	BOGENMESSER SX TG P30	AZADA ELICE SX P30 TUNGSTEN	SAPA SX P30 TUNGSTEN
24	R17820340	DENTE ATT-PIN ZGANCIO RAP.REV.	TOOTH ATTILA PINOCCHIO Quick F	DENTE ATTILA PINOCCHIO	ZAHN KLAUESTUTZE	DIENTE PUNTAL GARRA	DINTE ATT-PIN AT.RAPID.REVERS
25	R17820640	DENTE ATT-PIN TG ZGAN.RAP+REV	TOOTH ATT-PIN Tungsten Quick F	DENTE ATT-PIN Tungsten	ZAHN KLAUESTUTZE Tungsten	DIENTE PUNTAL GARRA Tungsten	DINTE ATT-PIN TG AT. RAP+REV
26	R17820680	DENTE ATTI/PIN RAPIDO REVERSIB	POINT ATTI/PIN RAPIDO REVERSIB	EMBOUT GRIFFE	ZAHN KLAUESTUTZE	DIENTE PUNTAL GARRA	DINTE ATT-PIN Atasare Rap.Rev.
27	R17820730	DENTE ATT-PIN Tungs Zg.Rap.Rev	TOOTH ATT-PIN Tungs.QuickF Rev	DENTE ATT-PIN Tungs Zg Rap Rev	ZAHN KLAUESTUTZE	DIENTE PUNTAL GARRA	DINTE ATT-PIN Tungs At.Rap Rev

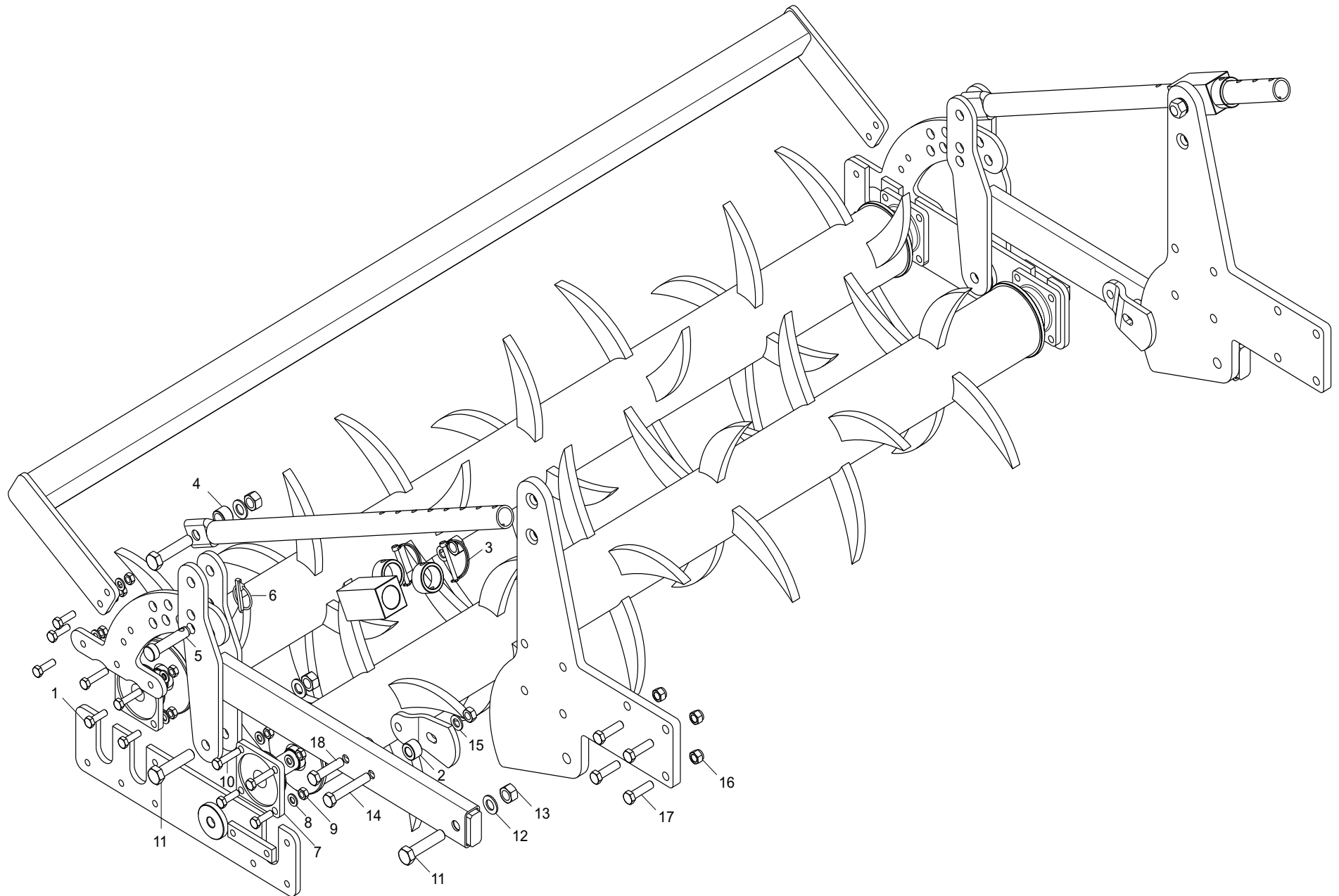



**DOPPIO RULLO POSTERIORE MECCANICO / DOUBLE REAR ROLLER MECHANICAL /  
 DOPPELTE NACHAUFWALZE MECHANISCHE / DOUBLE ROULEAU POSTERIEUR MECANIQUE /  
 DOBLE ROLLO POSTERIOR MECANICO / RULOU DUBLU POSTERIOR MECANIC**

TAV. 030

Pos.	Cod.	Descrizione	Description	Description	Benennung	Descripcion	Descriere
1	F01020152	VITE M12X1,75X40 U5737 8.8 ZB	BOLT M12X1,75X 40 5737 8.8 ZB	VIS M12X1,75X 40 5737 8.8 ZB	SCHR.M12X1,75X 40 5737 8.8 ZB	TORN.M12X1,75X 40 5737 8.8 ZB	SUR. M12X1,75X 40 5737 8.8 ZB
2	R17813230	BOCCOLA	BUSCHING	BOITE	BsCHSE	CASQUILLO	BUCSA DISTANTATOARE
3	F02200562	SPINA SICUR. D. 8X70 ZN	SPLIT PIN D.8X70 ZB	GOUPILLE D.8X70 ZB	BOLZEN D.8X70 ZB	PERNO D.8X70 ZB	STIFT DE SIGURANTA D.8X70 ZB
4	R17812000	BOCCOLA 21,7X33,7X23 ZN	BUSHING 21,7X33,7X23 ZN	BOITE 21,7X33,7X23 ZN	BsCHSE 21,7X33,7X23 ZN	CASQUILLO 21,7X33,7X23 ZN	BUCSA 21,7X33,7X23 ZN
5	R17813310	PERNO	PIN	PIVOT	BOLTZEN	TORNILLO	BOLT DE POZITIE ZB
6	F02200507	SPINA SCATTO D. 9 B/83 ZN	SNAP PIN D 9 B/83	FICHE A DETENTE D 9 B/83	EINRASTSTIFT D 9 B/83	CLAVIJA DE MUELLE D 9 B/83	STIFT RESORT D 9 ZB B/83
7	F04100073	SUPPORTO CUSCINETTO FY35TF	BEARING SUPPORT	SUPPORT ROULEMENT	LAGERHALTERUNG	SOPORTE COJINETE	SUPORT RULMENT FY35TF
8	F01410076	RONDELLA D12 UNI 6592 ZN	PLANE WASHER D12 UNI 6592 ZN	RONDELLE D12 UNI 6592 ZN	SCHEIBE D12 UNI 6592 ZN	ARANDELA D12 UNI 6592 ZN	SAIBA PLANA D12 UNI 6592 ZB
9	F01230059	DADO M12X1,75 D982 8 ZN	NUT M12X1,75 D982 8 ZB	ECRO.M12X1,75 D982 8 ZB	MUTT.M12X1,75 D982 8 ZB	TUER.M12X1,75 D982 8 ZB	PIUL.M12X1,75 D982 8 ZB
10	F01020160	VITE M12X1,75X60 U5737 8.8 ZG	BOLT M12X1,75X60 U5737 8.8 ZG	VIS M12X1,75X60 U5737 8.8 ZG	SCHRAUBE M12X1,75X60 U5737 8.8	TORNILLO M12X1,75X60 U5737 8.8	SURUB M12X1,75X 60 5737 8.8 ZB
11	F01020325	VITE M20X2,5X 90 U5737 10.9 ZD	BOLT 20X90 5737 10.9G GALVANI	VIS 20X90 5737 10.9G ZN	SCHRAUBE 20X90 5737 10.9G ZN	TORNILLO 20X90 5737 10.9G ZN	SURUB 20X90 5737 10.9 ZN
12	F01410124	ROS.M20 21X 37X 3 U6592 ZG	PLANE WASHER D20 UNI 6592 ZN	RONDELLE D20 UNI 6592 ZN	SCHEIBE D20 UNI 6592 ZN	ARANDELLA D20 UNI 6592 ZN	SAIBA PLANA D20 UNI 6592 ZB
13	F01230131	DADO M20X 2,5 D982 6 ZB	NUT M20X 2,5 D982 6 ZB	ECRO.M20X 2,5 D982 6 ZB	MUTT.M20X 2,5 D982 6 ZB	TUER.M20X 2,5 D982 6 ZB	PIUL.M20X 2,5 D982 6 ZB
14	F01020285	VITE M16X 2X100 U5737 8.8 ZN	BOLT 16X100 5737 8.8 GALVANIZ	VIS 16X100 5737 8.8 ZN	SCHRAUBE 16X100 5737 8.8 ZN	TORNILLO 16X100 5737 8.8 ZN	SURUB 16X100 5737 8.8 ZN
15	F01410100	ROS.M16 17X 30X 3 U6592 ZG	PLANE WASHER D16 UNI 6592 ZN	RONDELLE D16 UNI 6592 ZN	SCHEIBE D.16 UNI 6592 ZN	ARANDELA D16 UNI 6592 ZN	SAIBA M16 17X 30X 3 U6592 ZB
16	F01230085	DADO M16X 2 D982 8 ZB	NUT M16X 2 D982 8 ZB	ECROU M16X 2 D982 8 ZB	MUTT.M16X 2 D982 8 ZB	TUER.M16X 2 D982 8 ZB	PIUL.M16X 2 D982 8 ZB
17	F01020260	VITE M16X2X70 5739 8.8 ZB	BOLT M16X2X70 U5737 8.8 ZG	VIS M16X2X70 U5737 8.8 ZG	SCHRAUBE M16X2X70 U5737 8.8 ZG	TORNILLO M16X2X70 U5737 8.8 ZG	SURUB M16X2X70 5739 8.8 ZB
18	F01020262	VITE M16X 2X 80 U5737 8.8 ZG	BOLT M 16X80	VIS M 16X80	SCHRAUBE M 16X80	TORNILLO M 16X80	SURUB M16X 2X 80 U5737 8.8 ZB

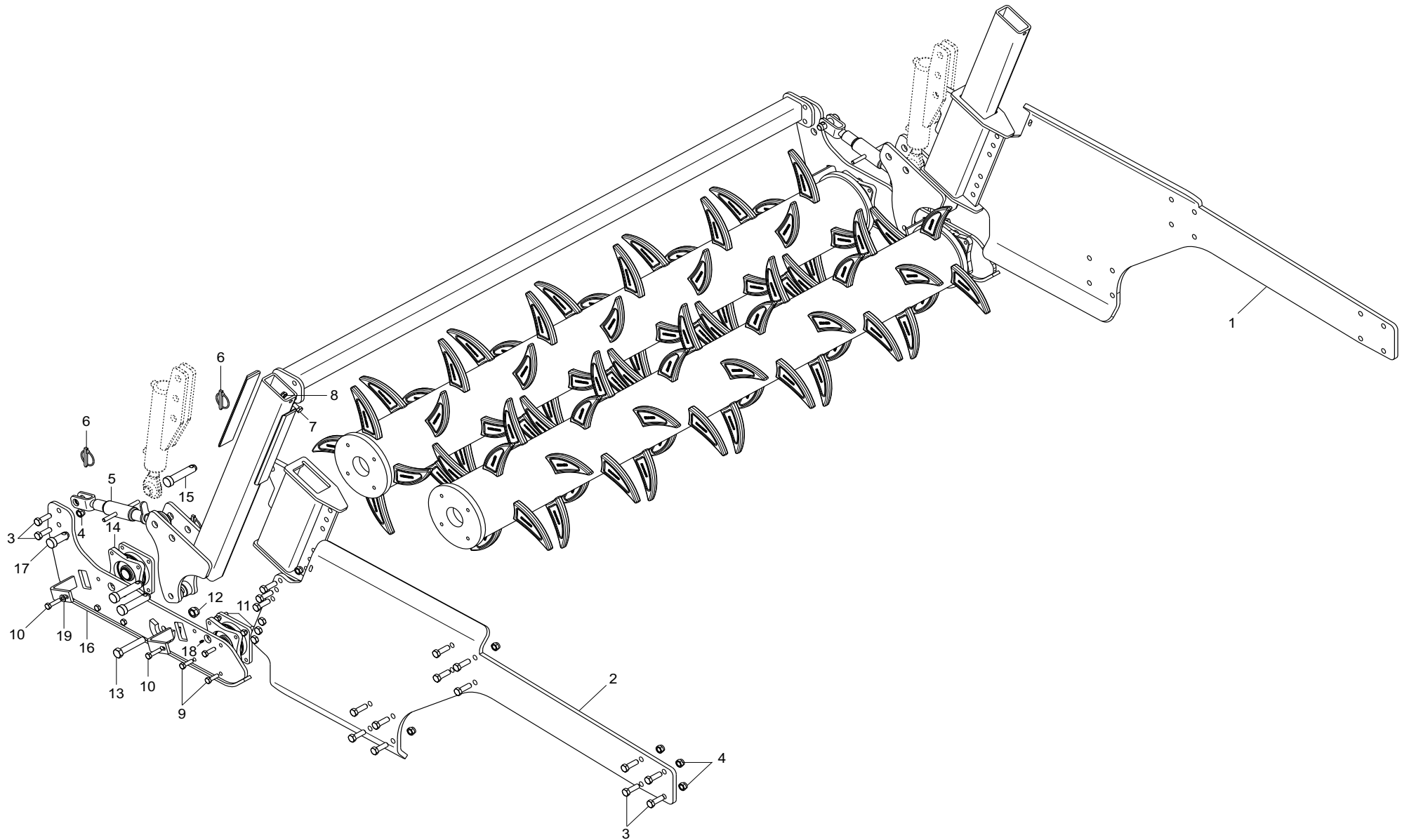

**DOPPIO RULLO POSTERIORE OLEODINAMICO / HYDRAULICAL DOUBLE REAR ROLLER /  
HYDRAULISCHEN DOPPELTE NACHAUFWALZE / DOUBLE ROULEAU POSTERIEUR HYDRAULIQUE /  
DOBLE ROLLO POSTERIOR HIDRAULICO / RULO DUBLU POSTERIOR OLEODINAMIC**

TAV. 040

Pos.	Cod.	Descrizione	Description	Description	Benennung	Descripcion	Descriere
1	R17815761	LAMA SUPPORTO REGOLAZIONE SX	SUPPORT BLADE ADJUSTMENT SX	SUPPORT LAME REGLAGE SX	HALTERUNG MESSER SX	CUCHILLA SOPORTE	LAMA SUPORT REGLARE SX
2	R17815751	PIASTRA SOPORTO REGOLAZIONE DX	RIGHT BLADE SUPPORT	LAMA SUPPORT DROIT	MESSER SUPPORT DX	CUCHILLA SOPORTO DX	LAMA SUPORT REGLARE DX
3	F01020252	VITE M16X 2X 50 U5737 8.8 ZB	BOLT M16X 2X 50 U5737 8.8 ZB	VIS M16X 2X 50 U5737 8.8 ZB	SCHR.M16X 2X 50 U5737 8.8 ZB	TORN.M16X 2X 50 U5737 8.8 ZB	SUR. M16X 2X 50 U5737 8.8 ZB
4	F01230085	DADO M16X 2 D982 8 ZB	NUT M16X 2 D982 8 ZB	ECROU M16X 2 D982 8 ZB	MUTT.M16X 2 D982 8 ZB	TUER.M16X 2 D982 8 ZB	PIUL.M16X 2 D982 8 ZB
5	F02450022	CILINDRO L=330 L=490 D25,4 ZD	CYLINDER L=330 L=490 D25,4 ZD	CYLINDRE L=330 L=490 D=25,4 ZD	ZYLINDER L=330 L=490 D=25,4 ZD	CILINDRO L=330 L=490 D25,4 ZD	CILINDRU L=330 L=490 D=25,4 ZD
6	F02200507	SPINA SCATTO D. 9 B/83 ZN	SNAP PIN D 9 B/83	FICHE A DETENTE D 9 B/83	EINRASTSTIFT D 9 B/83	CLAVIJA DE MUELLE D 9 B/83	STIFT RESORT D 9 ZB B/83
7	F01020508	VITE M12X1,75X25 U5739 8.8 ZN	BOLT M 12X25	VIS M 12 X 25	SCHRAUBE M 12 X 25	TORNILLO M 12 X 25	SURUB M12X1,75X25 5739 8.8 ZN
8	F01230059	DADO M12X1,75 D982 8 ZN	NUT M12X1,75 D982 8 ZB	ECRO.M12X1,75 D982 8 ZB	MUTT.M12X1,75 D982 8 ZB	TUER.M12X1,75 D982 8 ZB	PIUL.M12X1,75 D982 8 ZB
9	F01010288	VITE M12X1,25X35 U5740 8.8 ZN	SCREW M12X1,25X35 U5740 8.8 ZB	VIS M12X1,25X35 U5740 8.8 ZB	SCHR.M12X1,25X35 U5740 8.8 ZB	TORN.M12X1,25X35 U5740 8.8 ZB	SUR. M12X1,25X35 U5740 8.8 ZB
10	F01010292	VITE M12X1,25X45 U5740 8.8 ZG	BOLT M12X1,25X45 U5740 8.8 ZG	VIS M12X1,25X45 U5740 8.8 ZG	SCHRAUBE M12X1,25X45 U5740 8.8	TORNILLO M12X1,25X45 U5740 8.8	SUR. M12X1,25X45 U5740 8.8 ZB
11	F01020528	VITE M12X1,75X40 U5739 10.9 ZD	SCREW 12X40 5739 10.9 ZN	VIS 12X40 5739 10.9 ZN	SCHRAUBE 12X40 5739 10.9 ZN	TORNILLO 12X40 5739 10.9 ZN	SURUB 12X40 5739 10.9 ZN
12	F01230131	DADO M20X 2,5 D982 6 ZB	NUT M20X 2,5 D982 6 ZB	ECRO.M20X 2,5 D982 6 ZB	MUTT.M20X 2,5 D982 6 ZB	TUER.M20X 2,5 D982 6 ZB	PIUL.M20X 2,5 D982 6 ZB
13	F01020313	VITE M20X2,5X110 U5737 8.8 ZN	BOLT 20X110 5737 8.8 GALVANIZ.	VIS 20X110 5737 8.8 ZN	SCHRAUBE 20X110 5737 8.8 ZN	TORNILLO 20X110 5737 8.8 ZN	SURUB 20X110 5737 8.8 ZN
14	M43400468	COMP.SUPP.CUSC.OSCIL.H42 X RIC	FLOAT.BEARING SUPPORT H60	PALIER H=60	KOMPLETTE WALZEHALTER H.60	COJINETE H=60	RULMENT OSCILANT H.60 P.SCHIMB
15	F20100063	PERNO D25 L91 C40 ZN	PIN GASPARDO D25 L113 C40	PIVOT GASPARDO D25 L113 C40	BOLZEN GASPARDO D25 L113 C40	PERNO GASPARDO D25 L113 C40	BOLT GASPARDO D25 L113 C40
16	R17610160	ASSIEME SOPORTO RULLO	ANS. ROLLER SUPPORT	ANS. ROULEAU SUPPORT	ANS. HALLTERUNG ROLLE	ANS. SOPORTE RODILLO	ANSAMBLU SUPORT RULO
17	R17817910	PERNO ZB	PIN ZB	PIVOT ZB	BOLZEN ZB	PERNO ZB	BOLT ZB
18	F01100011	ING.M 6X1 7663-A 9SMNPB28 ZN	SPHERE NIPPLE M6X1/A	GRAISSEUR A BILLES M6X1/A	KUGELFETTBSCHSE M6X1/A	ENGRAS. DE ESFERAS M6X1/A	ING.M 6X1 7663-A 9SMNPB28 ZB
19	F01410076	RONDELLA D12 UNI 6592 ZN	PLANE WASHER D12 UNI 6592 ZN	RONDELLE D12 UNI 6592 ZN	SCHEIBE D12 UNI 6592 ZN	ARANDELA D12 UNI 6592 ZN	SAIBA PLANA D12 UNI 6592 ZB

TAV. 050

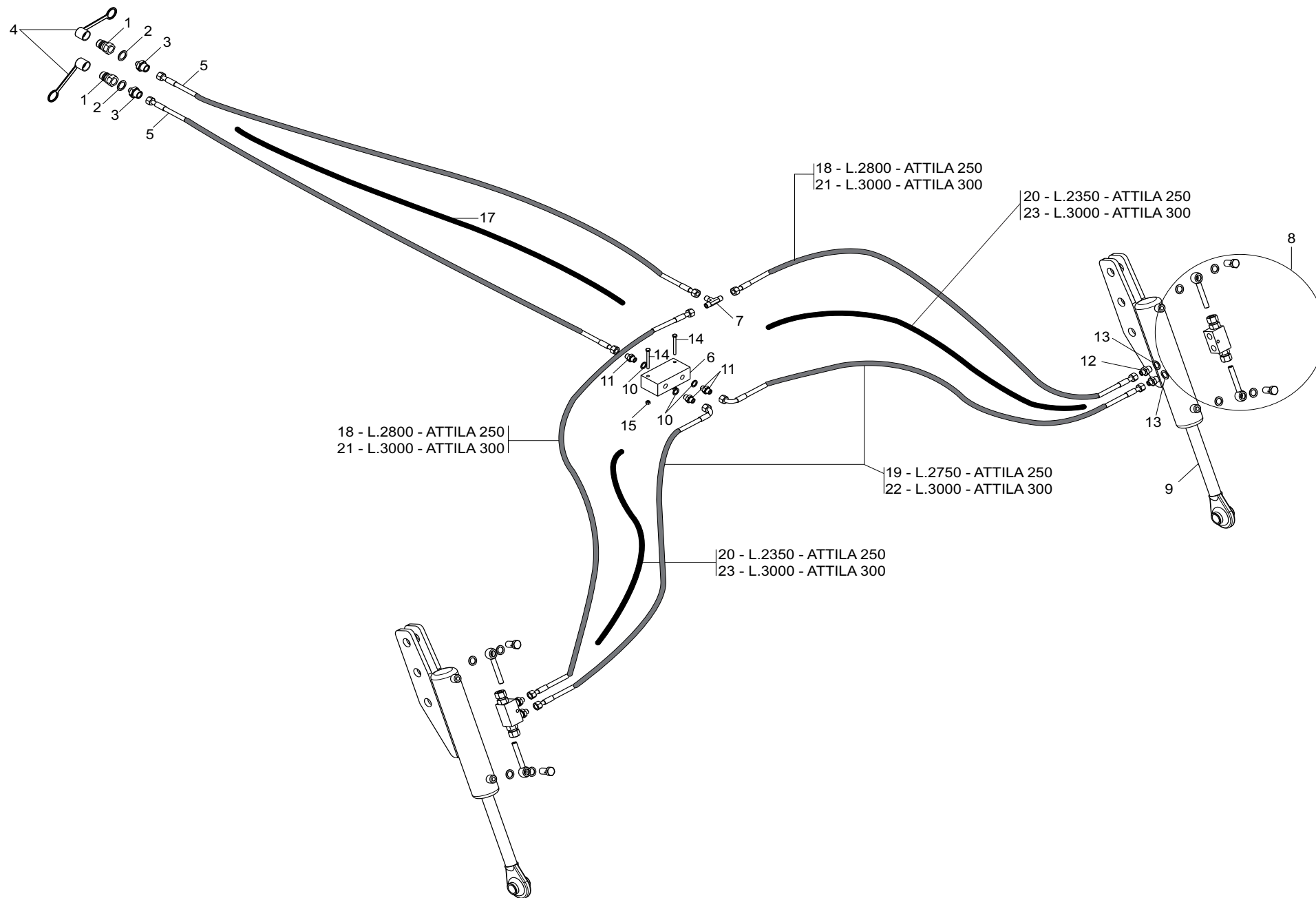

**IMPIANTO OLEODINAMICO / HYDRAULIC PLANT / HYDRAULISCHEN ANZUG / INSTALLATION HYDRAULIQUE /  
INSTALACION HIDRAULICA / INSTALAȚIE OLEODINAMICĂ**

**TAV. 050**

Pos.	Cod.	Descrizione	Description	Description	Benennung	Descripcion	Descriere
1	F03150935	INNESTO RAP.MASCH.1/2 A VALV.	QUICK CONNECT MALE CONE 1/2 CO	CONNEXION RAPIDE MALE CONE 1/2	SCHNELLKUPPLUNG GEWINDE KONISC	ACOPLAMIENTO RAPIDO MACHO CONO	CONECTARE RAPIDA TATA.CU 1/2
2	F03151237	RONDELLA RAME 21X27X1,5 -1/2"	1/2 COPPER WASHER	RONDELLE CUIVRE 1/2	UNTERLEGSCHEIBE KUPFER 1/2	ARANDELA COBRE 1/2	SAIBA RAME 1/2
3	F03150211	NIPPLO MM CIL-CIL 1/2-1/4 ZN	NIPLE 1/4-1/2	NIPLE 1/4-1/2	NIPLE 1/4-1/2	NIPLE 1/4-1/2	NIPLU 1/4-1/2
4	F05150325	CAPPUCCIO PROT.INNESTO RAP.1/2	COVER 1/2	COUVERCLE 1/2	DECKEL 1/2	TAPA 1/2	GLUGA CONECTARE 1/2
5	R17817920	TUBO 1/4 FF L=2000	PIPE 1/4 FF L=2000	TUBE 1/4 FF L=2000	ROHR 1/4 FF L=2000	TUBO 1/4 FF L=2000	TUB 1/4 FF L=2000
6	F03151044	DIVISORE DI FLUSSO A 2 VIE	FLOW DIVISOR	DIVISEUR DE FLUX	OELVERTEILER	DIVISOR DE FLUJO	DIVIZOR FLUX
7	F03151219	RACCORDO -T- MASCHIO 1/4 ZN	MALE T-UNION 1/4 ZINC.	RACCORD -T- MALE 1/4 ZING.	ANSCHLUSSTsCK -T- GEWINDE 1/4	UNIN -T- MACHO 1/4 CINC. R	ACORD -T- TATA 1/4 ZINC. R
8	F03151158	KIT VALVOLA BLOCCO 3/8 7014200	KIT CHECK VALVES 3/8 7014200	KIT CLAPET DE BLOCAGE 3/8	KIT RUCKSCHLAGVENTIL 3/8	KIT VALVULA ANTIRATORNO 3/8	KIT VALVA BLOC 3/8 7014200
9	R17811481	CILINDRO 30X70 - 280	CYLINDER 30X70 - 280	CYLINDRE 30X70 - 280	ZYLINDER 30X70 - 280	CILINDRO 30X70 - 280	ANSAMBLU CILINDRU 30X70 - 280
10	F03151238	RONDELLA RAME 13X19X1,5 -1/4"	1/4 COPPER WASHER	RONDELLE CUIVRE 1/4	UNTERLEGSCHEIBE KUPFER 1/4	ARANDELA COBRE 1/4	SAIBA RAME 1/4
11	F03150266	NIPPLO MM CIL-CIL 1/4-1/4 ZN	NIPPLE GALV.CYL.MALE 1/4 ZN	NIPPLE MALE CYL. 1/4 ZN	NIPPELZYL.1/4 ZN	NIPLE MACHO CIL.1/4 ZN	NIPLU TATA CIL.1/4 ZN
12	F03150310	NIPPLO MM CIL-CIL 3/8-1/4 ZN	NIPPLE GALV.CYL.MALE3/8-1/4 ZN	NIPPLE MALE CYL.3/8-1/4 ZN	NIPPELZYL.3/8-1/4 ZN	NIPLE MACHO CIL.3/8-1/4 ZN	NIPLU TATA CIL.3/8-1/4 ZN
13	F03151240	RONDELLA RAME 3/8	3/8 COPPER WASHER	RONDELLE CUIVRE 3/8	UNTERLEGSCHEIBE KUPFER 3/8	ARANDELA COBRE 3/8	SAIBA RAME 3/8
14	F01020416	VITE M 6X 1X 55 U5739 8.8 ZN	BOLT M 6X 1X 55 U5739 8.8 ZN	VIS M 6X 1X 55 U5739 8.8 ZN	SCHR.M 6X 1X 55 U5739 8.8 ZN	TORN.M 6X 1X 55 U5739 8.8 ZN	SUR. M 6X 1X 55 U5739 8.8 ZN
15	F01220011	DADO M 6X 1 D980 8 ZG	SELF LOCKING NUT M6	ECROU AUTOBL. M6	SELBSTSPERR.MUTTER M6	DADO AUTOBL. M6	PIULITA AUTOFRINARE M6 USM8-98
16	F05150058	FASCETTA POLYAM.7.8X550 31920	POLYAMIDE FASTENING STRAPS 9X5	COLLIER POLYAMIDE 9X508 31920	SHELLE POLYAMID 9X508 31920	ABRAZADERA POLIAMIDA 9X508 319	COLIER PLASTIC 9X508 31920
17	F03100383	GUAINA TELATA D=65 L=1750	SHEATH D=65 L=1750	GAINÉ D=65 L=1750	KABEL D=65 L=1750	VAINA D=65 L=1750	PROTECTIE TEXTILA D=65 L=1750
18	G17915100	TUBO 1/4 F-F L.2800	PIPE 1/4 F-F L.2800	TUBE 1/4 F-F L.2800	ROHR 1/4 F-F L.2800	TUBO 1/4 F-F L.2800	TUB 1/4 F-F L.2800
19	G15210551	TUBO 1/4R2 C-F L.2750 LM	PIPE 1/4R1 C-F L.2750 LM	TUBE 1/4R1 C-F L. 2750 LM	ROHR 1/4R1 C-F L.2750 LM	TUBO 1/4R1 C-F L.2750 LM	TUB 1/4R2 C-F L.2750 LM
20	F03100362	GUAINA TELATA D=65 L=2350	SHEATH D=65 L=2350	GAINÉ D=65 L=2350	KABEL D=65 L=2350	VAINA D=65 L=2350	PROTECTIE TEXTILA D=65 L=2350
21	R17814480	TUBO 1/4R2 F1/4-F1/4 L=3000	PIPE 1/4R2 F1/4-F1/4 L=3000	TUBE 1/4R2 F1/4-F1/4 L=3000	ROHR 1/4R2 F1/4-F1/4 L=3000	TUBO 1/4R2 F1/4-F1/4 L=3000	TUB 1/4R2 F1/4-F1/4 L=3000
22	G15210631	TUBO 1/4R2 C-F L.3000 LM	PIPE 1/4R2 C-F L.3000 LM	TUBE 1/4R2 C-F L. 3000 LM	ROHR 1/4R2 C-F L.3000 LM	TUBO 1/4R2 C-F L.3000 LM	TUB 1/4R2 C-F L.3000 LM
23	F03100371	GUAINA TELATA D=65 L=3000	SHEATH D=65 L=3000	GAINÉ D=65 L=3000	KABEL D=65 L=3000	VAINA D=65 L=3000	PROTECTIE D=65 L=3000

TAV. 060

BATTERIA DISCHI D.710 - 2,5 m - 17  
 BATTERIA DISCHI D.710 - 3,0 m - 19  
 BATTERIA DISCHI D.660 - 2,5 m - 20  
 BATTERIA DISCHI D.660 - 3,0 m - 21

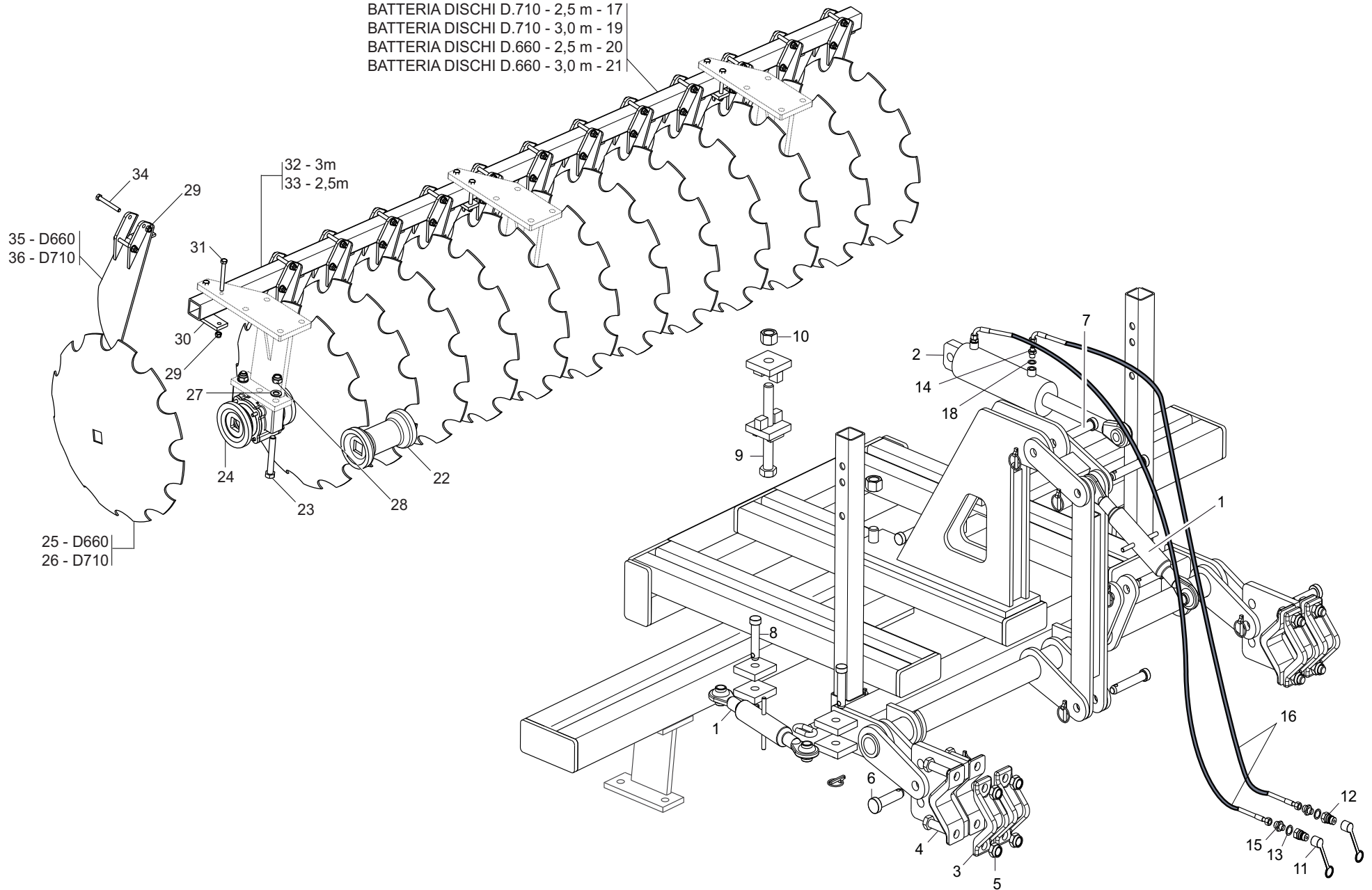

**DISCHI POSTERIORI / REAR DISCS / HINTEN DISC / DISQUE POSTERIEUR / DISCOS TRASERO /  
DISCURI POSTERIOARE**

TAV. 060

Pos.	Cod.	Descrizione	Description	Description	Benennung	Descripcion	Descriere
1	R17815000	TIRANTE TERZO PUNTO 19678	TIE-ROD THIRD POINT 19678	TRINGLE TROISIEME POINT 19678	ZUGSTANGE DRITTER PUNKT 19678	TIRANTE TERCER PUNTO 19678	TIRANT 3 PUNCTE 19678
2	G15313210	CILINDRO CARRELLO DIRECTA	CYLINDER CARRIAGE DIRECTA	CYLINDRE CHARIOT DIRECTA	ZYLINDER WAGEN DIRECTA	CILINDRO CARRETILLA DIRECTA	CILINDRU CARUCIOR DIRECTA
3	R17811170	SCONTRO PER TUBO 100	STRIKER PLATE 100	BUTEE 100	ANSCHLAG 100	ELEMENTO DE EMPALME 100	BRIDA FIXARE TEAVA 100
4	F01020343	VITE M24X 3X 80 U5737 10.9 ZD	BOLT M24X 3X 80 U5737 10.9 ZB	VIS M24X 3X 80 U5737 10.9 ZB	SCHR.M24X 3X 80 U5737 10.9 ZB	TORN.M24X 3X 80 U5737 10.9 ZB	SUR. M24X 3X 80 U5737 10.9 ZB
5	F01230144	DADO M24X 3 D982 8 ZB	NUT M24X 3 D982 8 ZB	ECROU M24X 3 D982 8 ZB	MUTTER M24X 3 D982 8 ZB	TUERCA M24X 3 D982 8 ZB	PIULITA M24X 3 D982 8 ZB
6	F20100078	PERNO D28 L93 C43 ZN	PIN D.28	GOUJON D.28	BOLZEN D.28	PERNO D.28	STIFT GASPARDO 28X99 ZN
7	F20100063	PERNO D25 L91 C40 ZN	PIN GASPARDO D25 L113 C40	PIVOT GASPARDO D25 L113 C40	BOLZEN GASPARDO D25 L113 C40	PERNO GASPARDO D25 L113 C40	BOLT GASPARDO D25 L113 C40
8	F20100062	PERNO 25X128 ZN	3RD POINT PIN	GOUJON 3EME POINT	BOLZEN 3. PUNKT	PERNO 3 PUNTO	PIVOT D.25
9	F01020356	VITE M30X 3,5X260 U5737 8.8 ZN	BOLT M30X 3,5X260 U5737 8.8 ZG	VIS M30X 3,5X260 U5737 8.8 ZG	SCHRAUBE M30X 3,5X260 U5737	TORNILLO M30X 3,5X260 U5737	SURUB M30X 3,5X260 U5737 8.8
10	F01210085	DADO M30X 3,5 U5593 5.8 ZN	NUT M30X 3.5 U5593 5.8 ZB	ECROU M30X 3.5 U5593 5.8 ZB	MUTTER M30X 3.5 U5593 5.8 ZB	TORN. M30X 3.5 U5593 5.8 ZB	PIULITA M30X 3.5 U5593 5.8 ZB
11	F05150325	CAPPUC.F X INN.M RAP.1/2 ROSSO	COVER 1/2	COUVERCLE 1/2	DECKEL 1/2	TAPA 1/2	GLUGA CONECTARE 1/2
12	F03150935	INNESTO RAP.MASCH.1/2 A VALV.	QUICK CONNECT MALE CONE 1/2 CO	CONNEXION RAPIDE MALE CONE 1/2	SCHNELLKUPPLUNG GEWINDE KONISC		ACOPLAMIENTO RAPIDO MACHO CONO
13	F03151237	ROS. 21 X27X1,5 RAME -1/2"	1/2 COPPER WASHER	RONDELLE CUIVRE 1/2	UNTERLEGSSCHEIBE KUPFER 1/2	ARANDELA COBRE 1/2	SAIBA RAME 1/2
14	F03150310	NIPPLO MM CIL-CIL 3/8-1/4 ZN	NIPPLE GALV.CYL.MALE3/8-1/4 ZN	NIPPLE MALE CYL.3/8-1/4 ZN	NIPPELZYL.3/8-1/4 ZN	NIPLE MACHO CIL.3/8-1/4 ZN	NIPLU TATA CIL.3/8-1/4 ZN
15	F03150211	NIPPLO MM CIL-CIL 1/2-1/4 ZN	NIPLE 1/4-1/2	NIPLE 1/4-1/2	NIPLE 1/4-1/2	NIPLE 1/4-1/2	NIPLU 1/4-1/2
16	G15413060	TUBO 1/4R2 CF1/4- F1/4 3850	TUBE 1/4R2 CF1/4-F1/4 3850	TUYAU 1/4R2 CF1/4-F1/4 3850	SCHLAUCH 1/4R2 CF1/4-F1/4 3850	TUBO 1/4R2 CF1/4-F1/4 3850	TUBO 1/4R2 CF1/4- F1/4 3850
17	R17818050	BATTERIA DEI DISCHI 2.5M	BATTERY DISK 2.5M	BATTERIE DU DISQUE	SCHLEIBEN 2.5M	DISCHI 2.5M	BATERIE DISC 2.5M
18	F03151240	ROS. 17 X23X1,5 RAME -3/8"	COPPER WASHER 17X23X1,5 3/8"	CUIRVE RONDELLA RAME 17X23X1,5	UNTERLEGSSCHEIBE 17X23X1,5 3/8"	ARANDELA COBRE 17X23X1,5	SAIBA RAMA 17X23X1,5 3/8"
19	R17818030	BATTERIA DEI DISCHI 3M	BATTERY DISK 3M	BATTERIE DU DISQUE 3M	SCHLEIBEN 3M	DISCHI 3M	BATERIE DISC 3M
20	R17818110	BATTERIA DEI DISCHI 2.5M D=660	BATTERY DISK 2.5M D=660	BATTERIE DU DISQUE 2,5M D=660	SCHLEIBEN 2,5M D=660	DISCHI 2,5M D=660	BATERIE DISC 2,5M D=660
21	R17818120	BATTERIA DEI DISCHI 3M D=660	BATTERY DISK 3M D=660	BATTERIE DU DISQUE 3M D=660	SCHLEIBEN 3M D=660	DISCHI 3M D=660	BATERIE DISC 3M D=660
22	R18420090	DISTANZIALE L=230	SPACER	ENTRETOISE	ABSTANDST_CK	DISTANCIADOR	DISTANTIER L=230
23	F01010178	VITE M20X1,5X140 U5738 8.8 ZN	BOLT M20X1,5X140 U5738 8.8 ZN	VIS M20X1,5X140 U5738 8.8 ZN	SCHRAUBE M20X1,5X140 U5738 8.8	TORNILLO M20X1,5X140 U5738 8.8	SURUB M20X1,5X140 U5738 8.8 ZN
24	R18420110	ASSIEME MOZZO	CLUTCH	EMBRYAGE	KUPPLUNG	FRICCION	ANSAMBLU BUTUC
25	R18420300	DISCO D=660	DISK D=660	DISQUE D=660	SCHEIBE D=660	DISCO D=660	DISC D=660
26	R17816690	DISCO D=710	DISK D=710	DISQUE D=710	SCHEIBE D=710	DISCO D=710	DISC D=710
27	F01430105	ROS.M20 21X 33X1,4 U8842J BR	WASHER D20 DIN 6798 D. INT. *	RONDELLE D20 DIN 6798 D.INT. *	UNT.SCHEIBE D20 DIN 6798 D.INT. *	ARANDELA D20 DIN 6798 D.INT. *	SAIBA M20 21X33X1,4 U8842J BR
28	F01230131	DADO M20X 2,5 D982 6 ZB	NUT M20X 2,5 D982 6 ZB	ECRO.M20X 2,5 D982 6 ZB	MUTT.M20X 2,5 D982 6 ZB	TUER.M20X 2,5 D982 6 ZB	PIUL.M20X 2,5 D982 6 ZB
29	F01230059	DADO M12X1,75 D982 8 ZN	NUT M12X1,75 D982 8 ZB	ECRO.M12X1,75 D982 8 ZB	MUTT.M12X1,75 D982 8 ZB	TUER.M12X1,75 D982 8 ZB	PIUL.M12X1,75 D982 8 ZB
30	R18420230	PIASTRA FISSAGGIO	BLADE	LAME	MESSER	CUCHILLA	PLACA DE FIXARE
31	F01020174	VITE M12X1,75X120 5737 8.8 ZN	BOLT 12X120 5737 8.8 GALVANIZ.	VIS 12X120 5737 8.8 ZN	SCHRAUBE 12X120 5737 8.8 ZN	TORNILLO 12X120 5737 8.8 ZN	SUR. M12X1,75X120 5737 8.8 ZB
32	R18420280	TUBO 60X60X6 L=3100	TUBE 60X60X6 L=3100	TUBE 60X60X6 L=3100	ROHR 60X60X6 L=3100	TUBO 60X60X6 L=3100	TUB 60X60X6 L=3100
33	R17860010	TUBO 60X60X6 L=2500	TUBE 60X60X6 L=2500	TUBE 60X60X6 L=2500	ROHR 60X60X6 L=2500	TUBO 60X60X6 L=2500	TUB 60X60X6 L=2500
34	F01020170	VITE M12X1,75X100 5737 8.8 Z	BOLT M 12X100	VIS M 12X100	SCHRAUBE M 12X100	TORNILLO M 12X100	SURUB M12X1,75X100 5737 8.8 ZB
35	R18420270	RASCHIATERRA	SOIL SCRAPER	DECROITTOIR	ABSTREIFER	RASCADOR	RAZUITOARE
36	R17860020	RASCHIATERRA	SOIL SCRAPER	DECROITTOIR	ABSTREIFER	RASCADOR	RAZUITOARE

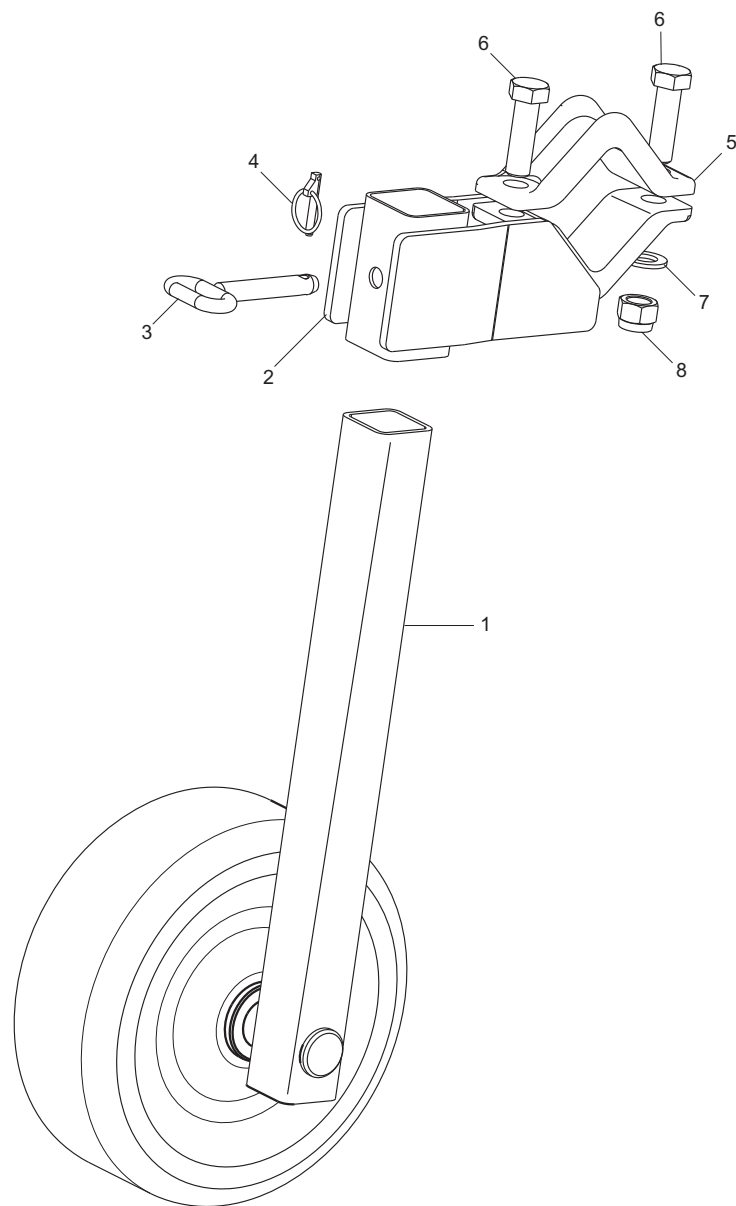



**RUOTE DI PROFONDITÀ / DEPTH WHEEL / BLOCK TIEFE / ROUE DE PROFONDEUR /  
RUEDA DE PROFUNDIDAD / ROATĂ DE ADÂNCIME**

TAV. 070

Pos.	Cod.	Descrizione	Description	Description	Benennung	Descripcion	Descriere
1	R18012160	RUOTA	WHEEL	ROUE	TIEFEN	RUEDA	ANSAMBLU ROATA
2	R17815720	SUPPORTO SOSTEGNO	SUPPORT SEALING	SUPPORT ETANCHEITE	HALTERUNG DICHTUNGS	SOPORTE AISLADOR	ANS.SUPPORT SUSTINERE
3	R17810440	PERNO ZN	PIN ZN	PIVOT ZN	BOLZEN ZN	PERNO ZN	BOLT ZN
4	F02200507	SPINA SCATTO D. 9 B/83 ZN	SNAP PIN D 9 B/83	FICHE A DETENTE D 9 B/83	EINRASTSTIFT D 9 B/83	CLAVIJA DE MUELLE D 9 B/83	STIFT RESORT D 9 ZB B/83
5	R17811170	SCONTRO PER TUBO 100	STRIKER PLATE 100	BUTEE 100	ANSCHLAG 100	ELEMENTO DE EMPALME 100	BRIDA FIXARE TEAVA 100
6	F01020343	VITE M24X 3X 80 U5737 10.9 ZB	BOLT M24X 3X 80 U5737 10.9 ZB	VIS M24X 3X 80 U5737 10.9 ZB	SCHR.M24X 3X 80 U5737 10.9 ZB	TORN.M24X 3X 80 U5737 10.9 ZB	SUR. M24X 3X 80 U5737 10.9 ZB
7	G18701590	RONDELLA 25X35X2,5 ZB	WASHER 25 x 35 x2,5 ZB	RONDELLE 25 x 35 x2,5 ZB	UNTERLEGSCHIEBE 25 x 35 x2,5	ARANDELA 25 x 35 x2,5 ZB	SAIBA 25X35X2,5 ZB
8	F01230144	DADO M24X 3 D982 8 ZN	SELF-LOCKING NUT NORM.24 ZB	ECROU AUTOB.NORM.24 ZB	SELBSTSPERR. MUTTER NORM.24 ZB	TUERCA AUTOB .NORM.24 ZB	PIUL.M24X 3 D982 8 ZN

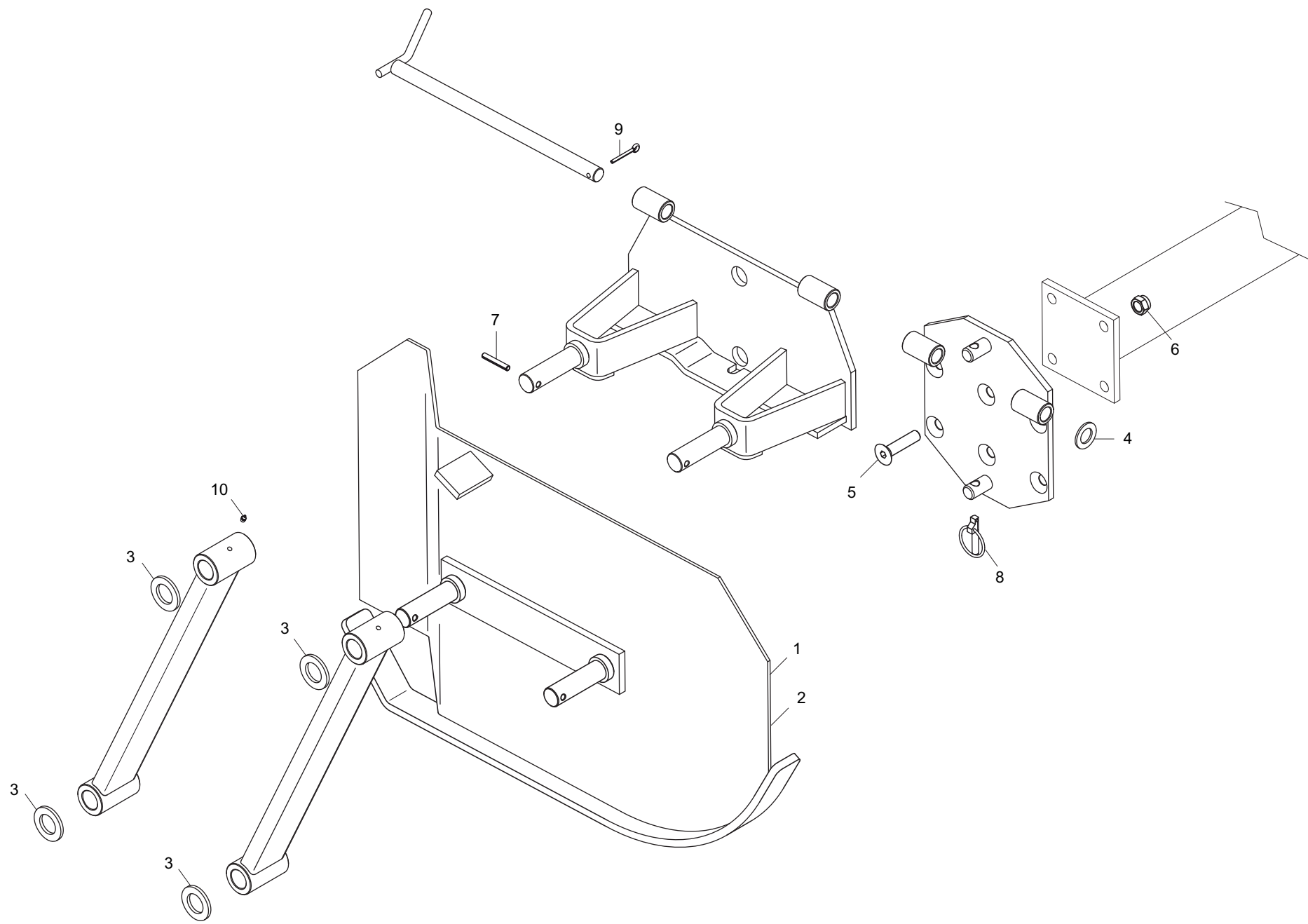

**BANDINELLA LATERALE MECCANICA / MECHANICAL STRIP CLOD / MECHANISCHE STREIFEN /  
MECANIQUE BANDE / BANDAS MECANICA / LIMITATOR LATERAL DE BRAZDĂ MECANIC**

TAV. 080

Pos.	Cod.	Descrizione	Description	Description	Benennung	Descripcion	Descriere
1	R17811821	BANDELLA DX	PROTECTION DX	PROTECTION DX	SCHUTZ DX	PROTECCION DX	ANSAMBLU PROTECTIE DX
2	R17811831	BANDELLA SX	PROTECTION SX	PROTECTION SX	SCHUTZ SX	PROTECCION SX	ANSAMBLU PROTECTIE SX
3	G18700570	RONDELLA 20X54X6	WASHER 20X54X6	RONDELLE 20X54X6	SCHEIBE 20X54X6	ARANDELA 20X54X6	SAIBA 20X54X6
4	F01410135	ROS.M22 23X 39X 3 U6592 ZG	PLANE WASHER D.22	BAGUE D.22	SCHEIBE D.22	ARANDELA D.22	SAIBA PLANA D.22 UNI 6592 ZB
5	F01030152	VITE M16X 2X70 U5933 8.8 ZN	BOLT M16X2X70 U5933 8.8 ZB	VIS M16X2X70 U5933 8.8 ZB	SCHRAUBE M16X2X70 U593308.8 ZN	TORNILLO M16X2X70 U5933 8.8 ZB	SUR.M16X 2X 70 U5933 8.8 ZB
6	F01230085	DADO M16X 2 D982 8 ZB	NUT M16X 2 D982 8 ZB	ECROU M16X 2 D982 8 ZB	MUTT.M16X 2 D982 8 ZB	TUER.M16X 2 D982 8 ZB	PIUL.M16X 2 D982 8 ZB
7	F02100144	SPINA E.P. 8X 50 U6873 C70 BR	ELASTIC PIN 8X50 1481	GOUJON ELASTIQUE 8X50 1481	SPANNHUELSE 8X50 1481	ESPINA ELASTICA 8X50 1481	STIFT ELASTIC 8X50 DIN 1481
8	F02200507	SPINA SCATTO D. 9 B/83 ZN	SNAP PIN D 9 B/83	FICHE A DETENTE D 9 B/83	EINRASTSTIFT D 9 B/83	CLAVIJA DE MUELLE D 9 B/83	STIFT RESORT D 9 ZB B/83
9	F02200229	COPIGLIA 5X 45 U1336 ZN	SPLIT PIN 5 X45 1336 GALVAN.	GOUPILLE 5 X45 1336 ZN	SPLINT 5 X45 1336 ZN	PASADOR 5 X45 1336 ZN	SPLINT 5 X45 1336 ZB
10	F01100048	ING.M 8X1,25 7663A 9SMNPB28 ZG	SPHERE NIPPLE M8X 1,25 A	GRAISSEUR A BILLES M8 X 1-25 A	KUGELFETTBSCHSE M8 X 1-25 A	ENGRAS. DE ESFERAS M8 X 1-25 A	INGRANS. SFERIC M8 X 1,25 A ZB

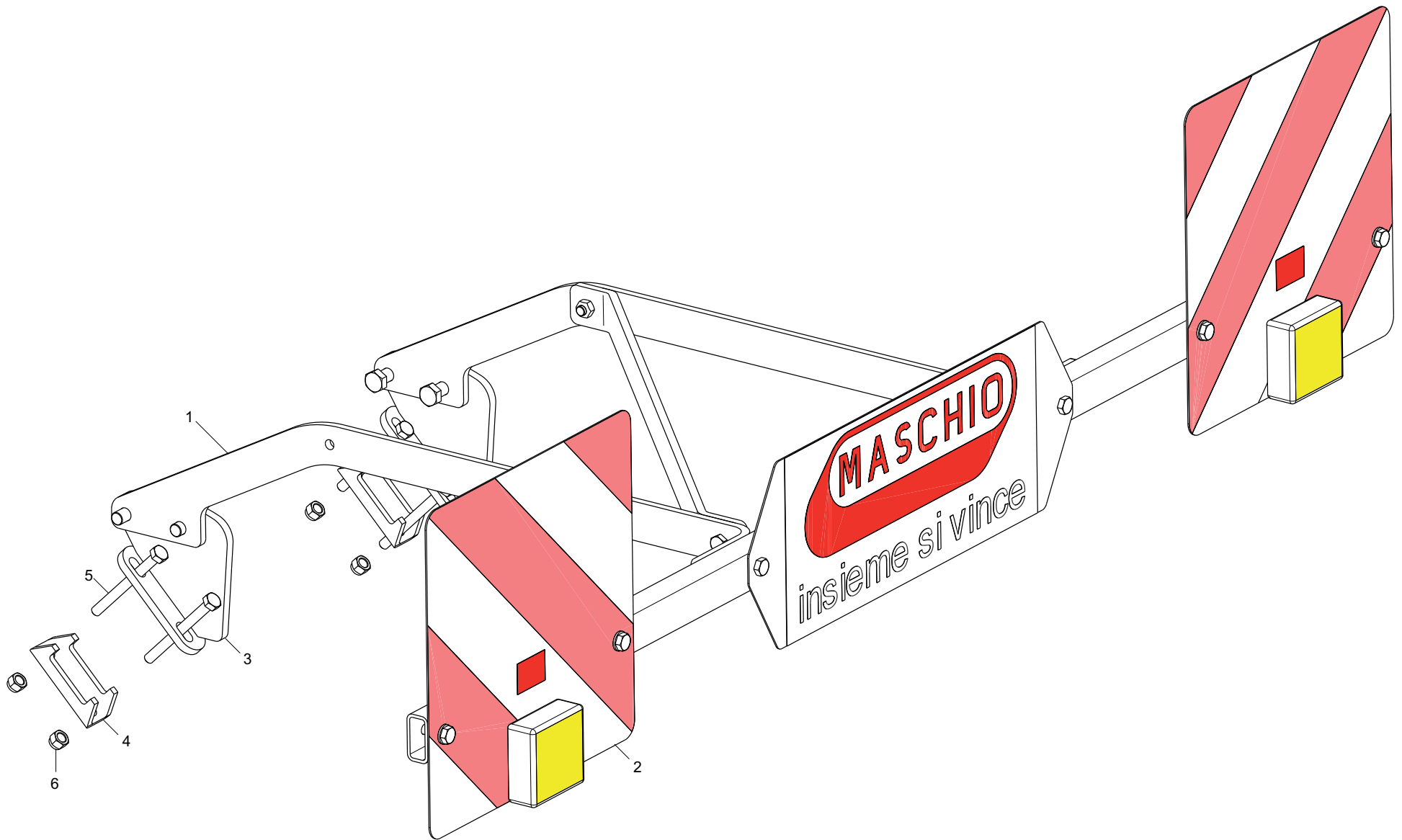

**KIT LUCI / LIGHTING KIT / LICHTER KIT / KIT D'ECLAIRAGE / KIT DE ILUMINACION / KIT LUMINI**

TAV. 090

Pos.	Cod.	Descrizione	Description	Description	Benennung	Descripcion	Descriere
1	M12400957	FANALE KIT LUCI	LAMP KIT LIGHTS	FEU KIT ECLAIRAGE	LAMPEN KIT LICHT	FAROL SET LUCES	FARURI PENTRU SET LUMINI
2	M12400956	KIT SUPPORTO BARRA LUCE	KIT SUPPORT	KIT SUPPORT	KIT HALTERUNG	KIT SOPORTE	KIT SUPORT BARRA DE LUMINI
3	R17841000	ASSIEME ATTACCO	COUPLING	FIXATION	KUPPLUNG	CONEXIN	ANSAMBLU ATASARE
4	G16740160	SCONTRO A U SP.8 2F13 83	U-SHAPED STOP TEETH B343SP.8	BUTEE EN U SP.8 2F13 83	U-ANSCHLAG SP.8 2F13 83	DIENTE DE PARADA A U ESP.8	BRIDA U SP.8 2F13 83
5	F01020174	VITE M12X1,75X120 5737 8.8 ZN	BOLT 12X120 5737 8.8 GALVANIZ.	VIS 12X120 5737 8.8 ZN	SCHRAUBE 12X120 5737 8.8 ZN	TORNILLO 12X120 5737 8.8 ZN	SUR. M12X1,75X120 5737 8.8 ZB
6	F01230059	DADO M12X1,75 D982 8 ZB	NUT M12X1,75 D982 8 ZB	ECRO.M12X1,75 D982 8 ZB	MUTT.M12X1,75 D982 8 ZB	TUER.M12X1,75 D982 8 ZB	PIUL.M12X1,75 D982 8 ZB

**USATE SEMPRE RICAMBI ORIGINALI  
ALWAYS USE ORIGINAL SPARE PARTS  
IMMER DIE ORIGINAL-ERSATZTEILE VERWENDEN  
EMPLOYEZ TOUJOURS LES PIECES DE RECHANGE ORIGINALES  
UTILIZAR SIEMPRE REPUESTOS ORIGINALES  
UTILIZAȚI ÎNTOTDEAUNA PIESE DE SCHIMB ORIGINALE**

**MASCHIO GASPARDO**



**MASCHIO GASPARDO**

**\*R19530770\***

**MASCHIO GASPARDO SpA**

**Sede legale e stabilimento produttivo**

Via Marcello, 73 - 35011 Campodarsego (Padova) - Italy  
Tel. +39 049 9289810  
Fax +39 049 9289900  
Email: [info@maschio.com](mailto:info@maschio.com)  
[www.maschionet.com](http://www.maschionet.com)

**MASCHIO DEUTSCHLAND GMBH**

Äußere Nürnberger Straße 5  
D - 91177 Thalmässing ng  
Deutschland  
Tel. +49 (0) 9173 79000  
Fax +49 (0) 9173 790079

**MASCHIO FRANCE Sarl**

1, Rue de Mérignan ZA  
F - 45240 La Ferte St. Aubin  
France  
Tel. +33 (0) 2.38.64.12.12  
Fax +33 (0) 2.38.64.66.79

**MASCHIO IBERICA S.L.**

Calle Cabernet, 10  
Poligono Industrial Clot de Moja  
Olerdola - 08734 Barcelona  
Tel. +34 93.81.99.058  
Fax +34 93.81.99.059

**MASCHIO-GASPARDO USA Inc**

120 North Scott Park Road  
Eldridge, IA 52748 - USA  
Ph. +1 563 2859937  
Fax +1 563 2859938  
e-mail: [info@maschio.us](mailto:info@maschio.us)

**MASCHIO GASPARDO SpA**

**Stabilimento produttivo**

Via Mussons, 7 - 33075  
Morsano al Tagliamento (PN) - Italy  
Tel. +39 0434 695410  
Fax +39 0434 695425  
Email: [info@gaspardo.it](mailto:info@gaspardo.it)

**ООО МАСКИО-ГАСПАРДО РУССИЯ**

404126, Россия, Волгоградская область,  
г.Волжский, ул.Пушкина, 117 \*6\*.  
Тел.: +78443525065  
факс: +78443525064  
e-mail: [info@maschio.ru](mailto:info@maschio.ru)  
<http://www.maschionet.com>

**MASCHIO GASPARDO ROMANIA SRL**

Strada Înfrățirii, Nr. 155  
315100 Chișineu - Criș  
Tel. +40 257 30 70 30  
Fax +40 257 30 70 40  
e-mail: [info@maschio.com](mailto:info@maschio.com)  
<http://www.maschio.com>

**MASCHIO MIDDLE EAST**

P.O. Box 922388  
Amman, 11192 Jordan  
Tel. 962 605511384  
Fax 962 6 5538398  
e-mail: [tahaeng@nets.com.jo](mailto:tahaeng@nets.com.jo)

**GASPARDO-MASCHIO TURCHIA**

**MASCHIO-GASPARDO CANADA Inc**  
**MASCHIO-GASPARDO CINA**  
**MASCHIO-GASPARDO POLAND**  
**MASCHIO-GASPARDO UCRAINA**  
**GASPARDO BIELORUSSIA**  
**MASCHIO-GASPARDO KOREA**