

MASCHIO GASPARDO

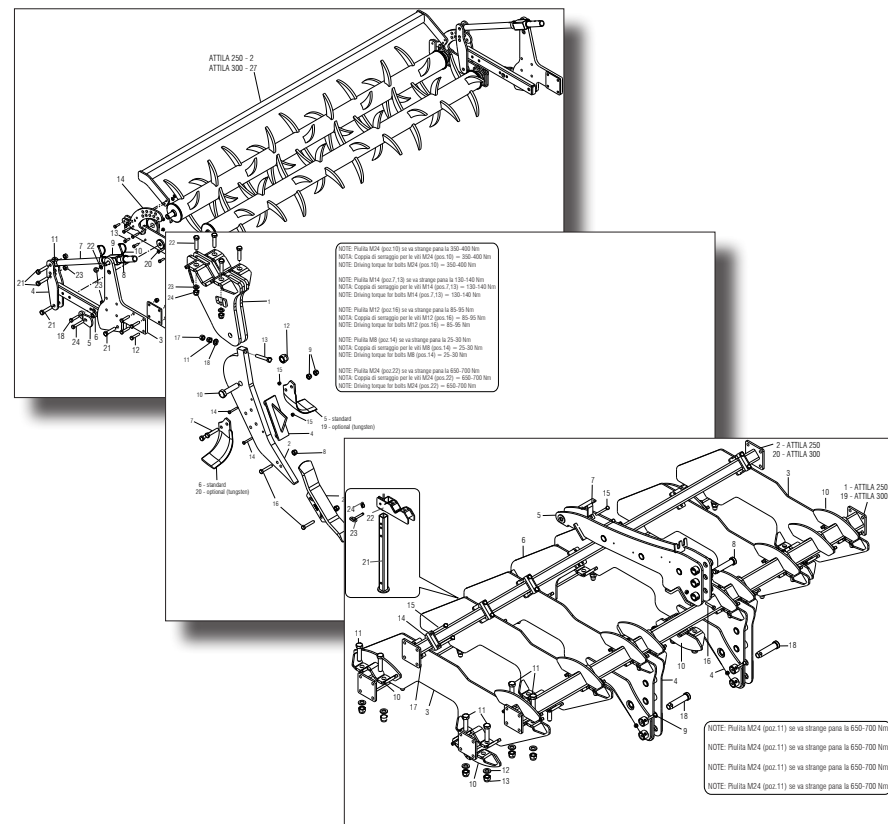

ATTLA

Cod: F07011059 02 / 2016

- *) Valido per Paesi UE
- *) Valid for EU member countries
- *) Gilt für EU-Mitgliedsländer
- *) Valable dans le Pays UE
- *) Válido para Países UE
- *) Valabil pentru țările UE

- IT** PARTI DI RICAMBIO
- EN** SPARE PARTS
- DE** ERSATZTEILE
- FR** PIÉCES DÉTACHÉES
- ES** PIEZAS DE REPUESTO
- RO** PIESE DE SCHIMB

PARTI DI RICAMBIO

Le ordinazioni delle parti di ricambio vanno fatte presso i nostri concessionari di zona e devono essere sempre corredate dalle seguenti indicazioni:

- **Tipo, modello e numero di matricola dell'attrezzatura.** Tali dati sono stampigliati nell'apposita targhetta di cui è dotata ogni attrezzatura.
- **Numero di codice della parte richiesta** rilevabile dal catalogo ricambi.
- **Descrizione del particolare e quantità richiesta.**
- **Numero della tavola.**
- **Mezzo di trasporto.** Nel caso questa voce non sia specificata, la Ditta Costruttrice, pur dedicando a questo servizio una particolare cura, non risponde di eventuali ritardi di spedizione dovuti a cause di forza maggiore.

Le spese di trasporto si intendono sempre a carico del destinatario. La merce viaggia a rischio e pericolo del committente anche se venduta franco destino.

NOTA: Il termine **(Dx) Destro** o **(Sx) Sinistro** della macchina o di parti di essa, è inteso guardando la macchina dalla parte posteriore. Le eccezioni saranno indicate.

SPARE PARTS

Orders must be transmitted through our area dealers and should always include the following indications:

- **Type, model and serial number of the machine.** These data are punched on the data plate with which every implement is equipped.
- **Code number of the required spare part.** This will be found in the spare parts catalogue.
- **Description of the part and required quantity.**
- **Table number.**
- **Means of dispatch.** If this item is not indicated, the Manufacturer, while dedicating particular care to this service, shall not be held responsible for delays in delivery caused by cases of force majeure.

Transport expenses shall always be at the consignee's charge. The goods travel at the purchaser's risk and peril even when sold ex destination.

NOTE: The symbols **(Dx) right** and **(Sx) left**, concerning the machine or single parts of it, are referred, as in the figure, to a rear view of them. Exceptions will be indicated.

ERSATZTEILE

Die Bestellungen müssen bei unseren Gebietshändler angegeben werden. Bei der Bestellung sind stets die folgenden Angaben zu machen:

- **Typ, Modell und Serien-Nummer des Geräts.** Diese Daten stehen auf dem Typenschild, mit dem jedes Gerät versehen ist.
- **Artikel Nr. der erforderlichen Ersatzteile.** Diese stehen im Ersatzteil-Katalog.
- **Beschreibung des Ersatzteils und die erforderliche Stückzahl.**
- **Tafelnummer.**
- **Versandmittel.** Wenn dieser Punkt nicht spezifiziert wird, haftet die Herstellerfirma nicht für etwaigen Lieferverzögerung aufgrund höherer Gewalt, auch wenn er diesen Service besonders aufmerksam abwickelt.

Die Frachtkosten gehen dagegen immer zu Lasten des Empfängers. Die Ware reist auf Gefahr und Risiko des Auftraggebers, auch wenn frei Haus verkauft vereinbart worden ist.

N.B.: Die Merkzeichen **(Dx) rechts** und **(Sx) links** betreffen eine rückwärtige Aussicht der Maschine oder Teile von ihr (siehe Bild). Ausnahmen werden gezeitigt.

PIECES DÉTACHÉES

Les ordres doivent être effectués auprès de nos concessionnaires de zone en précisant les indications suivantes:

- **Type, modèle et numéro de série de la machine.** Ces données sont gravées sur la plaque d'identification de chaque outil.
- **Numéro de code de la pièce détachée** indiqué sur le catalogue des pièces détachées.
- **Description de la pièce et quantité requise.**
- **Numéro de plan.**
- **Moyen d'expédition.** Si cette rubrique n'est pas indiquée, le Constructeur, bien que soucieux de ce service, ne répond pas des retards d'expédition pour des causes de force majeure. Les frais de transport sont toujours à la charge du destinataire. La marchandise voyage aux risques et périls de l'acheteur même si vendue franco de port.

N.B.: Les références **(Dx) droit** et **(Sx) gauche** de la machine ou des parties de la même, est entendue, comme de la figure, en regardant la machine de derrière dans le sens de marche.

RESPUESTOS

Los pedidos han de efectuarse en nuestros concesionarios de zona y deben incluir siempre las siguientes indicaciones:

- **Tipo, modelo y número de matrícula del equipo.** Dichos datos están impresos en la relativa placa presente en el equipo.
- **Número de código de la parte requerida** presente en el catálogo respuestas.
- **Descripción de la pieza y cantidad requerida.**
- **Numero de ilustración.**
- **Medio de transporte.** En caso que este ítem no esté especificado, el Fabricante, aún prestando la debidas consideraciones para este aspecto, no responde por eventuales retardos de env'o debidos a causas de fuerza mayor.

Los gastos de transporte se consideran siempre a cargo del destinatario. La mercadería viaja bajo riesgo y peligro del comprador, incluso cuando se vende franco destino.

N.B.: La referencia **(Dx) derecha** o **(Sx) izquierda** de la máquina o de sus componentes, se entien-de, como en la figura, mirando la máquina por la parte trasera. Se indicarán las excepciones.

PIESE DE SCHIMB

Comandarea pieselor de schimb se va face prin intermediul concesionarilor din zonă și trebuie să fie întotdeauna însoțite de următoarele date:

- **Tipul, modelul și numărul de matricolă al utilajului.** Aceste date se găsesc pe plăcuța de identificare a fiecărui utilaj.
- **Numărul de cod al piesei de schimb cerute**, care se găsește în manual.
- **Descrierea piesei de schimb și cantitatea cerută.**
- **Numărul desenului în care se găsește piesa.**
- **Mijloc de transport.** În cazul în care acesta nu este specificat, Firma Constructoare poate avea un regim special, nu răspunde de eventualele întârzieri de expediere datorate unor cauze de forță majoră.

Cheltuielile de transport sunt suportate de destinatar. Marfa este transportată pe riscul celui care efectuează comanda, chiar dacă marfa este vândută în condiții franco-destinatare.

NOTA: Termenul **(Dx) Dreapta** sau **(Sx) Stânga** a utilajului sau a părților acestuia, este privind utilajul din partea posterioară. Excepțiile vor fi indicate.

Nr. Tav.	Descrizione	Pag.	Nr. Tav.	Description	Pag.
TAV. 010	Telaio	4	TAV. 010	Cadre	4
TAV. 020	Elemento operatore	6	TAV. 020	Element operateur	6
TAV. 030	Doppio rullo posteriore meccanico	8	TAV. 030	Double rouleau posterieur mecanique	8
TAV. 040	Doppio rullo posteriore idraulico	10	TAV. 040	Double rouleau posterieur hydraulique	10
TAV. 050	Impianto oleodinamico rullo	12	TAV. 050	Installation hydraulique rouleau	12
TAV. 060	Bandinella laterale meccanica	14	TAV. 060	Protecion latérale mecanique	14
TAV. 070	Bandinella laterale idropneumatica	16	TAV. 070	Protecion latérale hydropneumatique	16
TAV. 080	Ruote di profondità	18	TAV. 080	Roue de profondeur	18
TAV. 090	Kit luci	20	TAV. 090	Kit d'eclairage	20

Nr. Tav.	Description	Pag.	Nr. Tav.	Descripcion	Pag.
TAV. 010	Frame	4	TAV. 010	Bastidor	4
TAV. 020	Operator element	6	TAV. 020	Elemento operadore	6
TAV. 030	Mechanical double rear roller	8	TAV. 030	Doble rodillo posterior mecanico	8
TAV. 040	Hydraulic double rear roller	10	TAV. 040	Doble rodillo posterior hidraulico	10
TAV. 050	Hydraulic plant roller	12	TAV. 050	Instalacion hidraulica rollo	12
TAV. 060	Mechanical side shield	14	TAV. 060	Bandas mecanicas	14
TAV. 070	Hydropneumatic side shield	16	TAV. 070	Bandas hidroneumáticas	16
TAV. 080	Depth wheel	18	TAV. 080	Rueda de profundidad	18
TAV. 090	Lighting kit	20	TAV. 090	Kit de iluminacion	20

Nr. Tav.	Beschreibung	Pag.	Nr. Tav.	Descriere	Pag.
TAV. 010	Rahmen	4	TAV. 010	Cadru	4
TAV. 020	Betreiber elemente	6	TAV. 020	Element operator	6
TAV. 030	Mechanische doppelte hintere walze	8	TAV. 030	Rulou dublu posterior mecanic	8
TAV. 040	Hydraulischen doppelte hintere walze	10	TAV. 040	Rulou dublu posterior hidraulic	10
TAV. 050	Walze hydraulischen Anzug	12	TAV. 050	Instalație hidraulică rulou	12
TAV. 060	Mechanische seitenschutzblechs	14	TAV. 060	Limitator de brazdă mecanic	14
TAV. 070	Hydropneumatische seitenschutzblechs	16	TAV. 070	Limitator de brazdă hidropneumatică	16
TAV. 080	Tiefenrad	18	TAV. 080	Roată de adâncime	18
TAV. 090	Lichter kit	20	TAV. 090	Kit lumini	20

TAV. 010

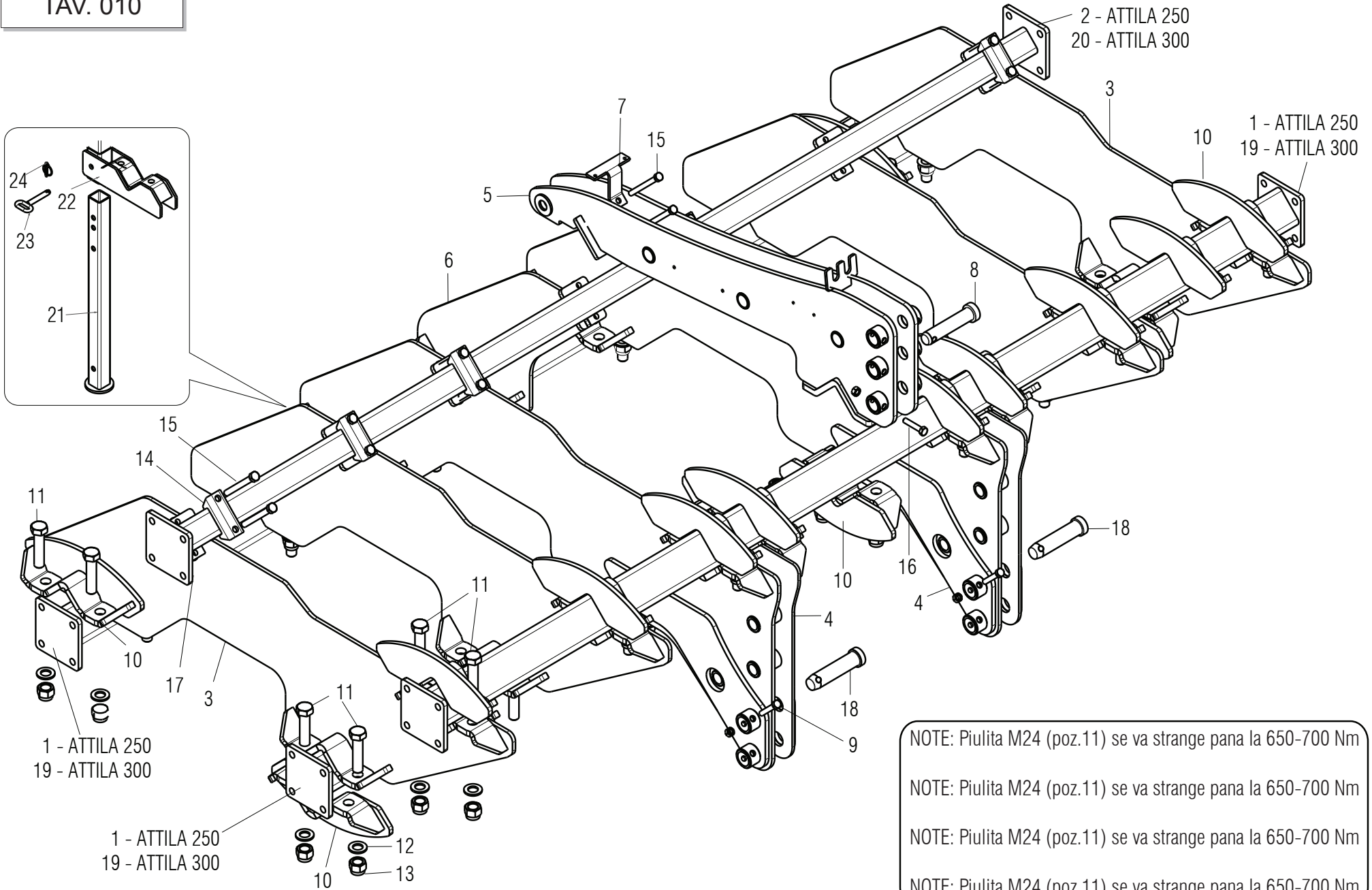

Pos.	Cod.	Descrizione	Description	Benennung	Description	Descripion	Descriere
1	R17810141	ASS.TELAIO 2370	FRAME 2370	HALTERUNG 2370	CHASSIS 2370	BASTIDOR 2370	ANS.SASIU 2370
2	R17810172	TELAIO POSTERIORE 2370	REAR FRAME 2370	HECKRAHMEN 2370	CHASSIS ARRIERE 2370	BASTIDOR POSTERIOR 2370	SASIU POSTERIOR 2370
3	R17813752	ASSIEME SUPPORTIO TELAIO	FRAME SUPPORT LEFT	RAHMENHALTERUNG LINK	SUPPORT CHASSIS GAUCHE	SOPORTE BASTIDOR IZQUIERDA	SUPORT SASIU SX
4	R17813743	ASSIEME TELAIO CENTRALE ATTILA	FRAME SUPPORT RIGHT	RAHMENHALTERUNG RECHT	SUPPORT CHASSIS DROIT	SOPORTE BASTIDOR DERECHA	SUPORT SASIU DX
5	R17843890	ASSIEME 3P	3P ASSEMBLY	3P ZUSAMMENBAU	ASSEMBLEE 3P	ASAMBLEA 3P	ASAMBLU 3P
6	R17813783	SUPPORTO TELAIO	FRAME SUPPORT	RAHMENHALTERUNG	SUPPORT CHASSIS	SOPORTE BASTIDOR	SUPPORT SASIU
7	R17810950	LAMELA SUPORT VALVA	SUPPORT BLADE VALVE	HALTERUNG MESSER VENTIL	SUPPORT LAME VALVE	CUCHILLA SOPORTE VALVULA	LAMA SUPORT VALVA
8	F20100101	PERNO D32 L128 C43 ZN	FRAME SUPPORT	RAHMENHALTERUNG	SUPPORT CHASSIS	SOPORTE BASTIDOR	SIPORT SASIU
9	F01020164	DADO M24 X3 D982 10 ZN	NUT M24X 3 D982 10 ZN	MUTTER M24X 3 D982 10 ZN	ECROU M24X 3 D982 10 ZN	TUERCA M24X 3 D982 10 ZN	PIULITA M24X 3 D982 10 ZN
10	R17821590	CAVALLOTTO	BRACKET PIPE 100	ANSCHLAG ROHR 100	BRIDE TUBE 100	EL.DE EMPALME TUBO 100	BRIDA TUB 100
11	F01020369	VIT.M24X 3X 90 U5737 10.9 ZB	BOLT M24X 3X 90 U5737 10.9ZB	SCHR. M24X 3X 90 U5737 10.9ZB	VIS M24X 3X 90 U5737 10.9ZB	TORN.M24X 3X 90 U5737 10.9ZB	SURUB M24X 3X 90 U5737 10.9ZB
12	G18701590	RONDELLA 25X35X2,5 ZN	WASHER 25 X35 X2,5 ZN	SCHEIBE 25 X35 X2,5 ZN	RONDELLE 25 X35 X2,5 ZN	ARANDELA 25 X35 X2,5 ZN	SAIBA 25X 35X 2,5 ZN
13	F01230146	DADO M24X 3 D982 10 ZN	NUT M24X 3 D982 10 ZN	MUTTER M24X 3 D982 10 ZN	ECROU M24X 3 D982 10 ZN	TUERCA M24X 3 D982 10 ZN	PIULITA M24X 3 D982 10 ZN
14	G16740160	SCONTRO A U SP.8 2F15 84	FLANGE U SHIMS 8 2F15 84	U-ANSCHLAG DICKE 8 2F15 84	BUTEE EN U CALE 8 2F15 84	ELEM. DE EMPAL.U ESP.8 2F15 84	BRIDA U GR.8 2F15 84
15	F01020174	VITE M12X1,75X120 5737 8.8 ZN	SCREW M12X1,75X120 5737 8.8 ZN	SCHR.M12X1,75X120 5737 8.8 ZN	VIS M12X1,75X120 5737 8.8 ZN	TORN.M12X1,75X120 5737 8.8 ZN	SURUB M12X1,75X120 5737 8.8 ZN
16	F01020160	VITE M12X1,75X60 5737 8.8 ZN	BOLT M12X1,75X60 5737 8.8 ZN	SCHRA.M12X1,75X60 5737 8.8 ZN	VIS M12X1,75X60 5737 8.8 ZN	TORN. M12X1,75X60 5737 8.8 ZN	SURUB M12X1,75X 60 5737 8.8 ZN
17	F01230059	DADO M12X1,75 D982 8 ZN	NUT M12X1,75 D982 8 ZN	MUTTER M12X1,75 D982 8 ZN	ECROU M12X1,75 D982 8 ZN	TUERCA M12X1,75 D982 8 ZN	PIULITA M12X1,75 D982 8 ZN
18	F20100141	PERNO D36 L128 C43 ZN	PIN D36 L128 C43 ZN	BOLTZEN D36 L128 C43 ZN	BOULON D36 L128 C43 ZN	PERNO D36 L128 C43 ZN	BOLT D36 L128 C43 ZN
19	R17810461	ASSIEME TELAIO ANTERIORE L2920	FRAME FRONT L2920	VORDERRAHMEN L2920	CHASSIS AVANT L2920	BASTIDOR DELANTERO L2920	ANSAMBLU SASIU ANTERIOR L2920
20	R17810482	TELAIO POSTERIORE 2920	REAR FRAME 2920	HECKRAHMEN 2920	CHASSIS ARRIERE 2920	BASTIDOR POSTERIOR 2920	SASIU POSTERIOR 2920
21	R17810380	ASS.PUNTELLO	PROP	STUTZE	ETRESILLON	PUNTAL	PICIOR
22	R17815722	SUPPORTO CARPENTERIA	ASSEMBLY SUPPORT	HALTERUNG ZUSAMMENBAU	ASSEMBLE SUPPORT	ASAMBLEA SUPPORTO	ANSAMBLU SUPORT
23	R17810441	PERNO D20 L110 ZN	BOLT D20 L110 ZN	BOLZEN D20 L110 ZN	BOULON D20 L110 ZN	PERNO D20 L110 ZN	BOLT D20 L110 ZN
24	F02200507	SPINAA SCATTO D 9 B/83	SNAP PIN D9 B/83 ZN	EINRASTSTIFT D9 B/83 ZN	FICHE A DETENTE D9 B/83 ZN	CLAVIJA DE MUELLE D9 B/83 ZN	STIFT RESORT D9 B/83 ZN

TAV. 020

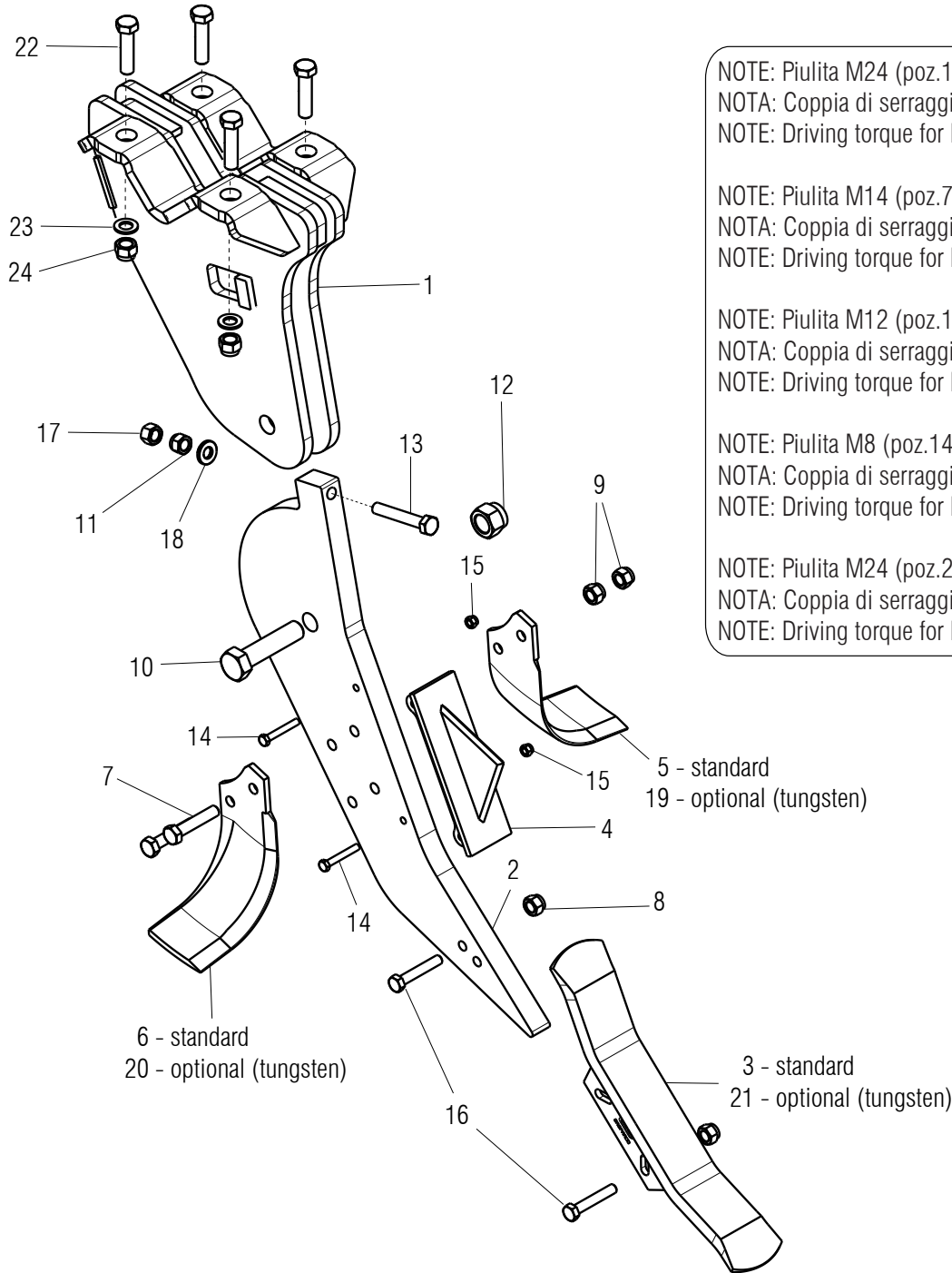

NOTE: Piulita M24 (poz.10) se va strange pana la 350-400 Nm
 NOTA: Coppia di serraggio per le viti M24 (pos.10) = 350-400 Nm
 NOTE: Driving torque for bolts M24 (pos.10) = 350-400 Nm

NOTE: Piulita M14 (poz.7,13) se va strange pana la 130-140 Nm
 NOTA: Coppia di serraggio per le viti M14 (pos.7,13) = 130-140 Nm
 NOTE: Driving torque for bolts M14 (pos.7,13) = 130-140 Nm

NOTE: Piulita M12 (poz.16) se va strange pana la 85-95 Nm
 NOTA: Coppia di serraggio per le viti M12 (pos.16) = 85-95 Nm
 NOTE: Driving torque for bolts M12 (pos.16) = 85-95 Nm

NOTE: Piulita M8 (poz.14) se va strange pana la 25-30 Nm
 NOTA: Coppia di serraggio per le viti M8 (pos.14) = 25-30 Nm
 NOTE: Driving torque for bolts M8 (pos.14) = 25-30 Nm

NOTE: Piulita M24 (poz.22) se va strange pana la 650-700 Nm
 NOTA: Coppia di serraggio per le viti M24 (pos.22) = 650-700 Nm
 NOTE: Driving torque for bolts M24 (pos.22) = 650-700 Nm

5 - standard
 19 - optional (tungsten)

6 - standard
 20 - optional (tungsten)

3 - standard
 21 - optional (tungsten)

ELEMENTO OPERATORE / OPERATOR ELEMENT / BETREIBER ELEMENTE / ELEMENT OPERATEUR / ELEMENTO OPERADORE / ELEMENT OPERATOR

TAV. 020

Pos.	Cod.	Descrizione	Description	Benennung	Description	Descrpcion	Descriere
1	R17820541	ASS. SUPPORTO ANCORA	SUPPORT TIP	SPITZE HALTERUNG	SUPPORT EMBOUT	SOPORTE PUNTAL	SUPPORT VARF
2	R17820561	LAMA DI PROTEZIONE	TIP	STUTZE	EMBOUT	PUNTAL	VARF
3	R17820681	DENTE ATTILA PINOCCHIO	TOOTH ATT/PIN REVERS. 2 HOLES	ZAHN	DENT	DIENTE	DINTE
4	R17820411	LAME ROMPIZOLLE	CLOD-BREAKING BLADE	MESSER SCHOLLENBRECHER	LAME BRISE-MOTTES	CUCHILLA DESTERRONADOR	LAMA SPARGATOR BRAZDA
5	M74100435	ZAPPA EL DX "B" SP.10	HELICOIDAL BLADE 10 MM RIGHT	RECHT BOGENMESSER	LAME HELICE DROIT	AZADA HELICE DERECHA	SAPA ELICOIDALA DX
6	M74100436	ZAPPA EL SX "B" SP.10	HELICOIDAL BLADE 10 MM LEFT	LINK BOGENMESSER	LAME HELICE GAUCHE	AZADA HELICE IZQUIERDA	SAPA ELICOIDALA SX
7	F01020207	VITE M14X2X70 U5737 8.8 ZN	BOLT M14X2X70 U5737 8.8 ZN	SCHRAUBE M14X2X70 U5737 8.8 ZN	VIS M14X2X70 U5737 8.8 ZN	TORNILLO M14X2X70 U5737 8.8 ZN	SURUB M14X 2X 70 U5737 8.8 ZN
8	F01230059	DADO M12X1,75 D982 8 ZN	NUT M12X1,75 D982 8 ZN	MUTTER M12X1,75 D982 8 ZN	ECROU M12X1,75 D982 8 ZN	TUERCA M12X1,75 D982 8 ZN	PIULITA M12X1,75 D982 8 ZN
9	F01230073	DADO M14X 2 D982 8 ZN	SELF LOCK. NUT M14X2 D982 8 ZN	SELBSTSP.MUTT. M14X2 D982 8 ZN	ECROU AUTOBL. M14X2 D982 8 ZN	TUERCA AUTOBL. M14X2 D982 8 ZN	PIULITA AUT. M14X2 D982 8 ZN
10	F01020344	VITE M24X3X100 U5737 10.9 ZD	BOLT M24X3X100 U5737 10.9 ZN	MUTTER M14 D6923 8.8 ZN	VIS M24X3X100 U5737 10.9 ZN	TUERCA M14 D6923 8.8 ZN	SURUB M24X100 U5737 10.9 ZN
11	F01260046	DADO FLANG.M14 D6923 8 ZN	NUT M14 D6923 8.8 ZN	MUTTER FLANG.M14 D6923 8 ZN	ECROU BRIDE M14 D6923 8 ZN	TUERCA FLANG.M14 D6923 8 ZN	PIULITA FLANG.M14 D6923 8 ZN
12	F01230144	DADO M24X 3 D982 8 ZN	NUT M24X 3 D982 8 ZN	MUTTER M24X 3 D982 8 ZN	ECROU M24X 3 D982 8 ZN	TUERCA M24X 3 D982 8 ZN	PIULITA M24X 3 D982 8 ZN
13	F01020214	VITE M14X 2X100 U5737 8.8 ZN	BOLT 14X100 5737 8.G GALVANIZ.	SCHRAUBE 14X100 5737 8.G ZN	VIS 14X100 5737 8.G ZN	TORNILLO 14X100 5737 8.G ZN	SURUB M14X 2X100 U5737 8.8 ZB
14	F01020077	VITE M 8X1,25X60 U5737 8.8 ZN	BOLT M8X1,25X60 U5737 8.8 ZN	SCHRA. M8X1,25X60 U5737 8.8 ZN	VIS M8X1,25X60 U5737 8.8 ZN	TORN. M8X1,25X60 U5737 8.8 ZN	SURUB M8X1,25X60 U5737 8.8 ZN
15	F01230034	DADO M 8X1,25 D982 8	SELF LOCK.NUT M8X1,25 D982 8ZN	SELBST.MUTT.M8X1,25 D982 8 ZN	ECROU AUTOBL.M8X1,25 D982 8 ZN	TUERCA AUTO. M8X1,25 D982 8 ZN	PIULITA AUT. M8X1,25 D982 8 ZN
16	F01020164	VITE M12X1,75X70 U5737 8.8 ZN	BOLT M12X1,75X70 U5737 8.8 ZN	SCHR. M12X1,75X70 U5737 8.8 ZN	VIS M12X1,75X70 U5737 8.8 ZN	TORN. M12X1,75X70 U5737 8.8 ZN	SURUB M12X1,75X70 U5737 8.8 ZN
17	F01200306	DADO M14X 2 U5588 6.8 ZN	NUT M14X2	MUTTER M14X2	ECROU M14X2	TUERCA M14X2	PIULITA M14X2 5588 6S ZN
18	R18700280	RONDELLA D.14 D.30 SP.4	WASHER D.14 D.30 SP.4	SCHEIBE D.14 D.30 SP.4	RONDELLE D.14 D.30 SP.4	ARANDELA D.14 D.30 SP.4	SAIBA D.14 D.30 GR.4
19	R17820860	ZAPPA EL DX "B" SP.10 TUNG	RIGHT HEL.BLADE THIKN.10 TUNG.	RECHT BOGENMESS.DICKE 10 TUNG.	LAME HELICE DROIT ÉP.10 TUNG.	AZADA HEL.DERECHA ESP.10 TUNG.	SAPA ELICOIDALA DX SP.10 TUNGS
20	R17820870	ZAPPA EL SX "B" SP.10 TUNG	LEFT HEL.BLADE THIKN.10 TUNG.	LINK BOGENMESS.DICKE 10 TUNG.	LAME HELICE GAUCHE ÉP.10 TUNG.	AZADA HEL.IZQUIER.ESP.10 TUNG.	SAPA ELICOIDALA SX SP.10 TUNGS
21	R17820731	DENTE TUNGSTENO ATTILA-PINOC.	TOOTH TG ATTILA-PINOCCHIO	ZAHN TG ATTILA-PINOCCHIO	DENT TG ATTILA-PINOCCHIO	DIENTE TG ATTILA-PINOCCHIO	DINTE TG ATTILA-PINOCCHIO
22	F01020369	VIT.M24X 3X 90 U5737 10.9 ZB	BOLT M24X 3X 90 U5737 10.9ZB	SCHR. M24X 3X 90 U5737 10.9ZB	VIS M24X 3X 90 U5737 10.9ZB	TORN.M24X 3X 90 U5737 10.9ZB	SURUB M24X 3X 90 U5737 10.9ZB
23	G18701590	RONDELLA 25X35X2,5 ZN	WASHER 25 X35 X2,5 ZN	SCHEIBE 25 X35 X2,5 ZN	RONDELLE 25 X35 X2,5 ZN	ARANDELA 25 X35 X2,5 ZN	SAIBA 25X 35X 2,5 ZN
24	F01230146	DADO M24X 3 D982 10 ZN	NUT M24X 3 D982 10 ZN	MUTTER M24X 3 D982 10 ZN	ECROU M24X 3 D982 10 ZN	TUERCA M24X 3 D982 10 ZN	PIULITA M24X 3 D982 10 ZN

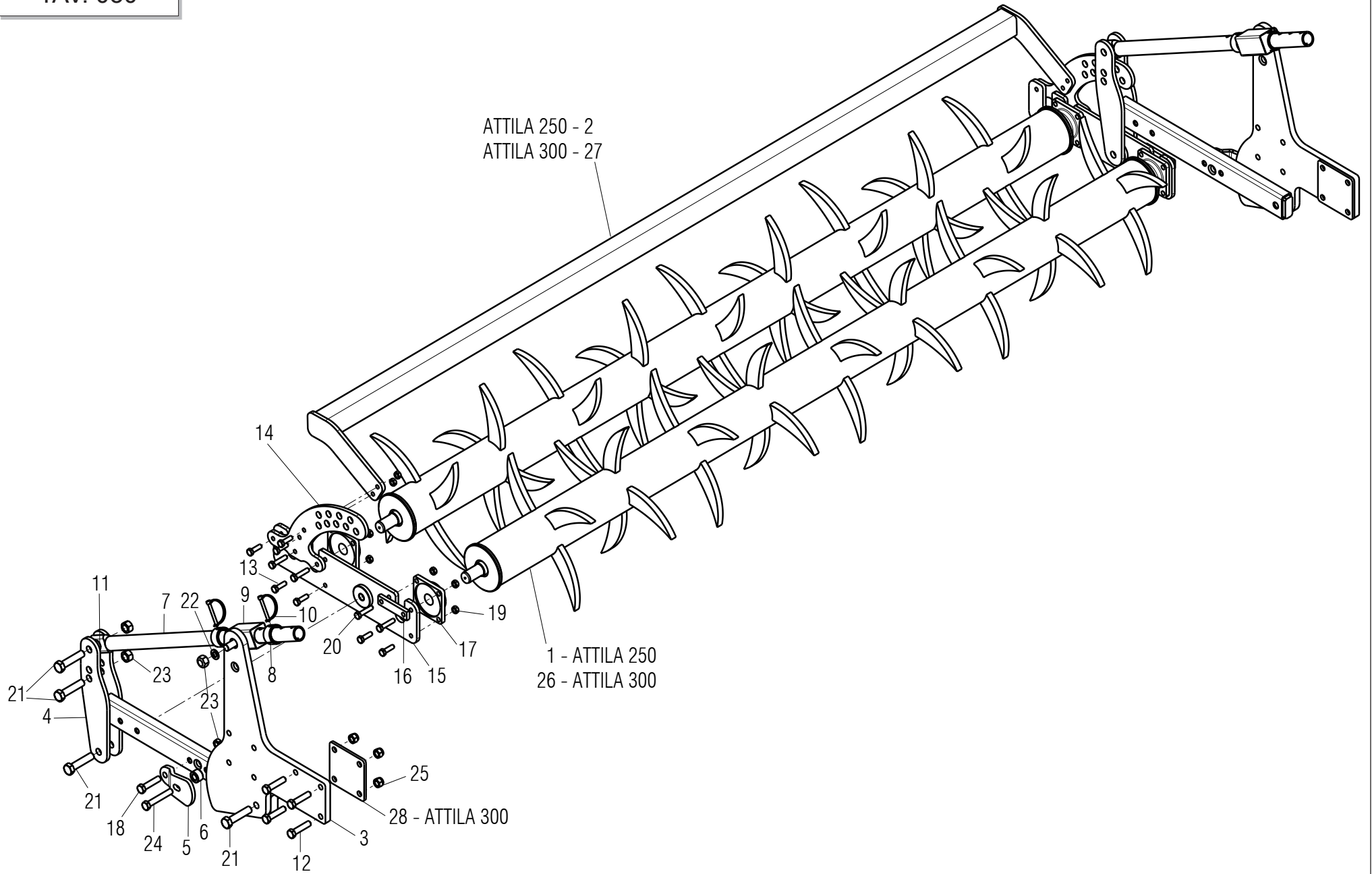

**DOPPIO RULLO POSTERIORE MECCANICO / MECHANICAL DOUBLE REAR ROLLER / MECHANISCHE DOPPELTE NINTERE
WALZE / DOUBLE ROULEAU POSTERIEUR MECANIQUE / DOBLE RODILLO POSTERIOR MECANICO / RULOU DUBLU
POSTERIOR MECANIC**

TAV. 030

Pos.	Cod.	Descrizione	Description	Benennung	Description	Descrpcion	Descriere
1	R17813361	ASS.RULLO 2,5 32 DENTI	ROLLER 2,5 32 TEETH	ROLLE 2,5 32 ZAHN	ROULEAU 2,5 32 DENTS	RODILLO 2,5 32 DIENTES	ANS.RULOU 2,5 32 DINTI
2	R17813380	SUPPORTO PROTEZIONE	SUPPORT GUARD	SCHUTZ	SUPPORT PROTECTION	SOPORTE PROTECCION	ANSAMBLU SUPORT PROTECTIE
3	R17815180	STAFFA SUPPORTO RULLO	ROLLER SUPPORT PLATE	ROLLE HALTERUNG PLATTE	PLAQUE SOPORTE ROULEAU	PLACA SOPORTE RODILLO	PLACA SUPORT RULOU
4	R17813140	ASS.SUPPORTO RULLO	ROLLER SUPPORT	ROLLE HALTRUNG	SUPPORT ROULEAU	SOPORTE RODILLO	ANS.SUPPORT RULOU
5	R17813130	PIATTO DI SUPPORTO	SUPPORT PLATE	HALTERUNGPLATTE	PLAQUE DE SUPPORT	PLACA DE SOPORTE	PLACA DE SUPORT
6	R17813230	BOCCOLA DISTANZIALE	BUSHING	BUCHSE	BUSHING	CASQUILLO	BUCSA DISTANTATOARE
7	R17811910	TUBO REGOLAZIONE	ADJUSTMENT PIPE	ROHR EINSTELLUNG	TUBE REGLAGE	TUBO REGULACIN	TUB REGLAJ
8	R17811960	BOCCOLA PER REGOLAZIONE ZN	BUSHING ADJUSTMENT ZN	EINSTELLBsCHSE ZN	BOITE REGLAGE ZN	CASQUILLO REGULACIN ZN	BUCSA PENTRU REGLARE ZN
9	R17811950	TUBO REGOLAZIONE ZN	ADJUSTMENT TUBE ZN	ROHR EINSTELLUNG ZN	TUBE REGLAGE ZN	TUBO REGULACIN ZN	ANSAMBLU TUB REGLARE ZN
10	F02200562	SPINA SICUR. D. 8X70 ZN	SNAP PIN D.8X 70 ZN	SCHERSTIFT D.8X 70 ZN	FICHE EL. D.8X70 ZN	CLAVIJA D.8X 70 ZN	STIFT RESORT D.8X70 ZN
11	R17812000	BOCCOLA 21,7X33,7X23 ZN	BUSHING 21,7X33,7X23 ZN	BUCHSE 21,7X33,7X23 ZN	BUSHING 21,7X33,7X23 ZN	CASQUILLO 21,7X33,7X23 ZN	BUCSA 21,7X33,7X23 ZN
12	F01020260	VITE M16X2X70 U5737 8.8 ZN	BOLT M16X2X70 U5737 8.8 ZN	SCHRAUBE M16X2X70 U5737 8.8 ZN	VIS M16X2X70 U5737 8.8 ZN	TORNILLO M16X2X70 U5737 8.8 ZN	SURUB M16X2X70 U5739 8.8 ZN
13	F01020152	VITE M12X1,75X40 5737 8.8 ZN	BOLT M12X1,75X40 U5737 8.8 ZN	SCHR.M12X1,75X 40 U5737 8.8 ZN	VIS M12X1,75X 40 U5737 8.8 ZN	TORN.M12X1,75X 40 U5737 8.8 ZN	SURUB M12X1,75X40 U5737 8.8 ZN
14	R17813120	LAMA DI REGOLAZIONE	BLADE ADJUSTMENT	HALTERUNG MESSER	LAME REGLAGE	CUCHILLA SOPORTE	LAMA DE REGLARE
15	R17813110	ASS.SUPPORTO RULLO	ROLLER SUPPORT	ROLLE HALTERUNG	SOPORTE ROULEAU	SOPORTE RODILO	ANS.SUPPORT RULOU
16	R17813240	PIASTRA DI ATTACCO	FIXING PLATE	KUPPLUNGSPLATTE	PLAQUE DE RACCORD	PLACA DE CONEXIN	PLACA DE POZITONARE
17	F04100073	SUPPORTO CUSCINETTO FY35TF	BEARING SUPPORT FY35TF	LAGERHALTERUNG FY35TF	SUPPORT ROULEMENT FY35TF	SOPORTE COJINETE FY35TF	SUPPORT RULMENT FY35TF
18	F01020262	VITE M16X2X80 U5737 8.8 ZN	BOLT M16X2X80 U5737 8.8 ZN	SCHRAUBE M16X2X80 U5737 8.8 ZN	VIS M16X2X80 U5737 8.8 ZN	TORNILLO M16X2X80 U5737 8.8 ZN	SURUB M16X 2X 80 U5737 8.8 ZN
19	F01230059	DADO M12X1,75 D982 8 ZN	NUT M12X1,75 D982 8 ZN	MUTTER M12X1,75 D982 8 ZN	ECROU M12X1,75 D982 8 ZN	TUERCA M12X1,75 D982 8 ZN	PIULITA M12X1,75 D982 8 ZN
20	F01020160	VITE M12X1,75X60 U5737 8.8 ZN	BOLT M12X1,75X60 U5737 8.8 ZN	SCHRA.M12X1,75X60 U5737 8.8 ZN	VIS M12X1,75X60 U5737 8.8 ZN	TORN. M12X1,75X60 U5737 8.8 ZN	SURUB M12X1,75X 60 5737 8.8 ZN
21	F01020325	VITE M20X2,5X 90 U5737 10.9 ZD	BOLT M20X2,5X 90 U5737 10.9 ZD	SCHRA.M20X2,5X 90 U5737 10.9 ZD	VIS M20X2,5X 90 U5737 10.9 ZD	TORN. M20X2,5X 90 U5737 10.9 ZD	SURUB M20X2,5X 90 U5737 10.9 ZD
22	F01410124	ROS.M20 21X 37X 3 U6592 ZN	WASHER M20 21X37X3 U6592 ZN	SCHIBE M20 21X37X3 U6592 ZN	RONDELLE M20 21X37X3 U6592 ZN	ARANDELA M20 21X37X3 U6592 ZN	SAIBA M20 21X37X3 U6592 ZN
23	F01230131	DADO M20X 2,5 D982 6 ZN	NUT M20X 2,5 D982 6 ZN	MUTTER M20X 2,5 D982 6 ZN	ECROU M20X 2,5 D982 6 ZN	TUERCA M20X 2,5 D982 6 ZN	PIULITA M20X 2,5 D982 6 ZN
24	F01020285	VITE M16X2X100 U5737 8.8 ZN	BOLT M16X2X100 U5737 8.8 ZN	SCHRA.M16X2X100 U5737 8.8 ZN	VIS M16X2X100 U5737 8.8 ZN	TORN.M16X2X100 U5737 8.8 ZN	SURUB M16X2X100 U5737 8.8 ZN
25	F01230085	DADO M16X 2 D982 8 ZN	NUT M16X 2 D982 8 ZN	MUTTER M16X 2 D982 8 ZN	ECROU M16X 2 D982 8 ZN	TUERCA M16X 2 D982 8 ZN	PIULITA M16X 2 D982 8 ZN
26	R17813371	ASS.RULLO 3 36 DENTI	ROLLER 3 36 TEETH	ROLLE 3 36 ZAHN	ROULEAU 3 36 DENTS	RODILLO 3 36 DIENTES	ANS.RULOU 3 36 DINTI
27	R17813391	SUPPORTO PROTEZIONE	SUPPORT GUARD	SCHUTZ	SUPPORT PROTECTION	SOPORTE PROTECCION	ANSAMBLU SUPORT PROTECTIE
28	R17812620	PIATTO	PLATE	PLATTE	PLAQUE	PLACA	PLACA

TAV. 040

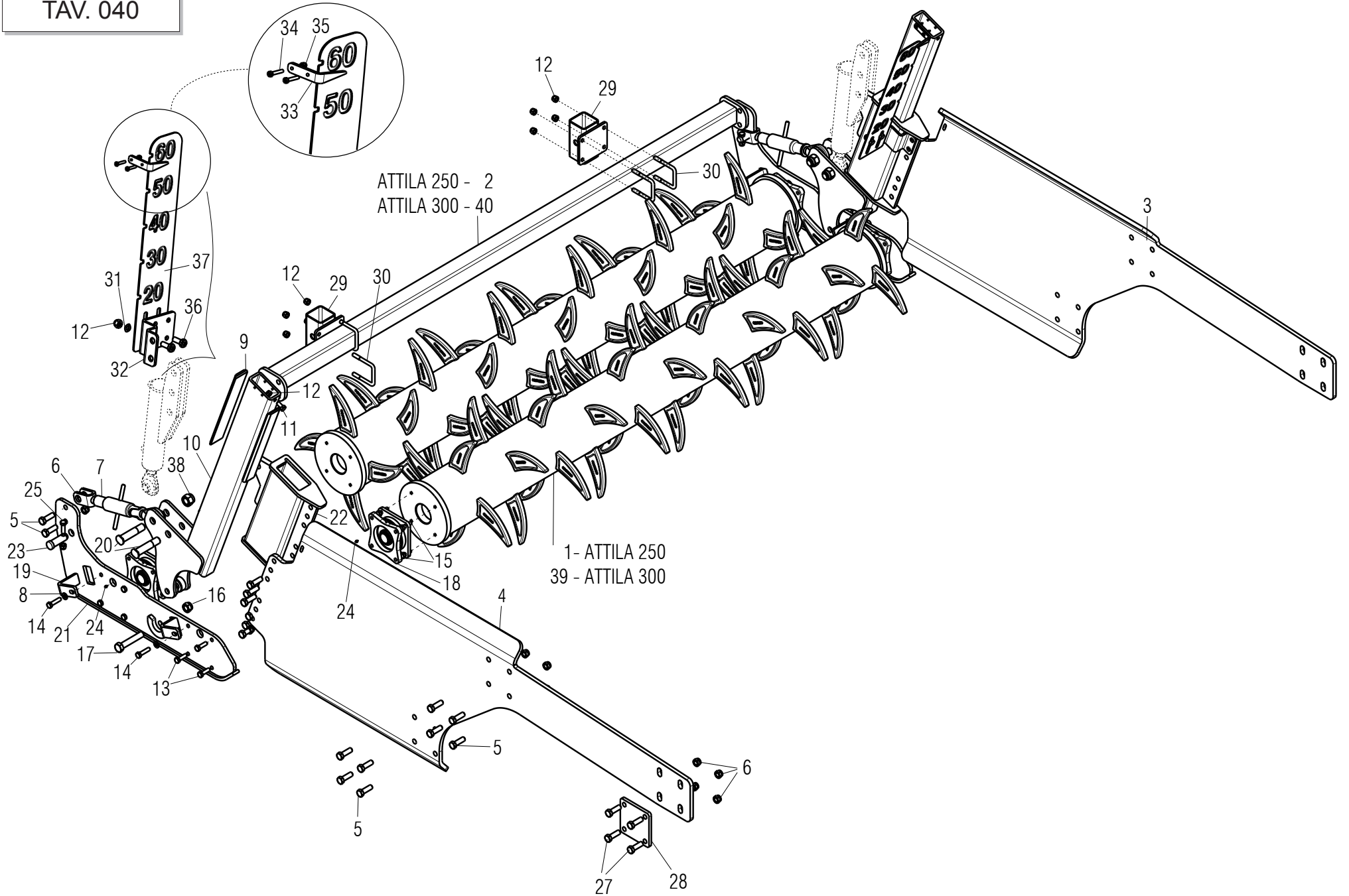

DOPPIO RULLO POSTERIORE OLEODINAMICO / HYDRAULICAL DOUBLE REAR ROLLER / HYDRAULISCHEN DOPPELTE HINTERE WALZE / DOUBLE ROULEAU POSTERIEUR HYDRAULIQUE / DOBLE RODILLO POSTERIOR HIDRAULICO / RULO DUBLU POSTERIOR OLEODINAMIC

TAV. 040

Pos.	Cod.	Descrizione	Description	Benennung	Description	Descrpcion	Descriere
1	R17811192	RULLO L=2,5 44 DENTI	ROLLER L=2,5 44 TEETH	WALTZE L=2,5 44 ZAHN	ROULEAU L=2,5 44 DENTS	RODILLO L=2,5 44 DIENTES	RULO L=2,5 44 DINTI
2	R17811432	ASSIEME PROTEZIONE 2,5M	ASSEMBLY GUARD 2,5M	ZUSAMMENBAU SCHUTZ 2,5M	ASSEMBLEE PROTECTION 2,5M	ASAMBLEA PROTECCION 2,5M	ANSAMBLU PROTECTIE 2,5M
3	R17815763	FIANCATA SUPPORTO RULLO SX	SUPPORT BLADE ADJUSTMENT SX	SUPPORT LAME REGLAGE SX	MESSER HALTERUNG ANPASSUNG SX	CUCHILLA SOPORTE AJUSTE SX	LAMA SUPORT REGLARE SX
4	R17815753	FIANCATA SUPPORTO RULLO DX	SUPPORT BLADE ADJUSTMENT DX	SUPPORT LAME REGLAGE DX	MESSER HALTERUNG ANP DX	CUCHILLA SOPORTE AJUSTE DX	LAMA SUPORT REGLARE DX
5	F01020252	VITE M16X2X50 U5737 8.8 ZN	BOLT M16X 2X 50 U5737 8.8 ZN	SCHRAUBE M16X2X50 U5737 8.8 ZN	VIS M16X 2X 50 U5737 8.8 ZN	TORNILLO M16X2X50 U5737 8.8 ZN	SURUB M16X 2X 50 U5737 8.8 ZN
6	F01230085	DADO M16X 2 D982 8 ZN	NUT M16X 2 D982 8 ZN	MUTTER M16X 2 D982 8 ZN	ECROU M16X 2 D982 8 ZN	TUERCA M16X 2 D982 8 ZN	PIULITA M16X 2 D982 8 ZN
7	F02450022	MART*M.L= 330 L= 490 D=25,4 ZD	TIE-ROD L=330 L=490 D=24.4 ZN	ZUGSTANGE L=330 L=490 D25,4 ZN	TRINGLE L=330 L=490 D=25,4 ZN	TIRANTE L=330 L=490 D=25,4 ZN	TIRANT L=330 L=490 D=24.4 ZN
8	F01410076	ROS.M12 13X 24X2,5 U6592 ZN	WASHER D12 U6592 ZN	SCHLEIBE D12 U6592 ZN	RONDELLE D12 U6592 ZN	ARANDELA D12 U6592 ZN	SAIBA D12 U6592 ZN
9	R17811331	LAMA DI SCORRIMENTO	BLADE SLIDING	GLEITMESSER	LAME DE GLISSEMENT	CUCHILLAS DE DESPLAZAMIENTO	PLACA DE GLISARE
10	R17610171	LEVA SCORRIMENTO RULLI	ROLLER SLIDING BLADE	LAME DE GLISSEMENT	GLEITMESSER	CUCHILLAS	PLACA
11	F01020508	VITE M12X1,75X25 U5739 8.8 ZN	BOLT M12X1,75X25 U5739 8.8 ZN	SCHR. M12X1,75X25 U5739 8.8 ZN	VIS M12X1,75X25 U5739 8.8 ZN	TORN. M12X1,75X25 U5739 8.8 ZN	SURUB M12X1,75X25 U5739 8.8 ZN
12	F01230059	DADO M12X1,75 D982 8 ZN	NUT M12X1,75 D982 8 ZN	MUTTER M12X1,75 D982 8 ZN	ECROU M12X1,75 D982 8 ZN	TUERCA M12X1,75 D982 8 ZN	PIULITA M12X1,75 D982 8 ZN
13	F01010288	VITE M12X1,25X35 U5740 8.8 ZN	BOLT M12X1,25X35 U5740 8.8 ZN	SCHR.M12X1,25X35 U5740 8.8 ZN	VIS M12X1,25X35 U5740 8.8 ZN	TORN.M12X1,25X35 U5740 8.8 ZN	SURUB M12X1,25X35 U5740 8.8 ZN
14	F01010292	VITE M12X1,25X45 U5740 8.8 ZN	BOLT M12X1,25X45 U5740 8.8 ZN	SCHRA.M12X1,25X45 U5740 8.8 ZN	VIS M12X1,25X45 U5740 8.8 ZN	TORN. M12X1,25X45 U5740 8.8 ZN	SURUB M12X1,25X45 U5740 8.8 ZN
15	F01020528	VITE M12X1,75X40 U5739 10.9 ZN	BOLT M12X1,75X40 U5739 10.9ZN	SCHR.M12X1,75X40 U5739 10.9 ZN	VIS M12X1,75X40 U5739 10.9 ZN	TORN.M12X1,75X40 U5739 10.9 ZN	SURUB M12X1,75X40 U5739 10.9ZN
16	F01230131	DADO M20X 2,5 D982 6 ZN	NUT M20X 2,5 D982 6 ZN	MUTTER M20X 2,5 D982 6 ZN	ECROU M20X 2,5 D982 6 ZN	TUERCA M20X 2,5 D982 6 ZN	PIULITA M20X 2,5 D982 6 ZN
17	R17614350	PERNO FILET. D20 L110 C40 ZN	BOLT FILET. D20 L110 C40 ZN	BOLZEN FILET.D20 L110 C40 ZN	VIS FILET. D20 L110 C40 ZN	TORNILLO D20 L110 C40 ZN	BOLT CU FILET D20 L110 C40 ZN
18	M43400413	KIT SUPPORTO RULLO OSCILL.H=60	BEARING H=60	LAGER H=60	PALIER H=60	COJINETE H=60	RULMENT OSCILANT H=60
19	R17811450	RASCHIATERRA	SOIL SCRAPER	ERDSCHABER	RACLEUR	RASCADOR DE TIERRA	RAZUITOARE
20	R17614340	PERNO FILET. D25 L118 C40 ZN	BOLT FILET. D25 L118 C40 ZN	BOLZEN FILET. D25 L118 C40 ZN	VIS FILET. D25 L118 C40 ZN	TORNILLO D25 L118 C40 ZN	BOLT FILET. D25 L118 C40 ZN
21	R17610160	SUPPORTO RULLO	ROLLER SUPPORT	ROLLER HALTERUNG	ROULEAU SUPPORT	RODILLO SOPORTE	SUPORT RULO
22	R17811321	SUPPORTO SCORRIMENTO RULLI	ROLLER SLIDING SUPPORT	RUOLEAU SUPPORT	ROLLER HALTERUNG	RODILLO SOPORTE	SUPORT RULO
23	R17817910	SPINA D25 L55,5 ZN	BOLT D25 L55,5 ZN	BOLZEN D25 L55,5 ZN	BOULON D25 L55,5 ZN	TORNILLO D25 L55,5 ZN	BOLT D25 L55,5 ZN
24	F01100011	ING. M 6X1 7663-A 9SMNPB28 ZN	GREASE NIPPLE M6X1 7663-A ZN	SCHMIERBUECHE M6X1 7663-A ZN	GRAISS. A BILLE M6X1 7663A ZN	ENGRAS. DE ESFERAS M6X1 7663-A	CAP GRESOR M6X1 DREPT A/1 ZN
25	F01020154	VITE M12X1,75X45 U5737 8.8 ZN	BOLT M12X1,75X45 U5737 8.8 ZN	SCHR.M12X1,75X 45 U5737 8.8 ZN	VIS M12X1,75X 45 U5737 8.8 ZN	TORN.M12X1,75X 45 U5737 8.8 ZN	SURUB M12X1,75X45 U5737 8.8 ZN
26	M43400705	GUARNIZIONE METALLICA H60	GASKET H60	DICHTUNG H60	JONT H60	JUNTA H60	GARNITURA METALICA H60
27	F01020256	VITE M16X2X60 U5737 8.8 ZN	BOLT M16X2X60 U5737 8.8 ZN	SCHRAUBE M16X2X60 U5737 8.8 ZN	VIS M16X 2X60 U5737 8.8 ZN	TORNILLO M16X2X60 U5737 8.8 ZN	SURUB M16X 2X60 U5737 8.8 ZN
28	R17810160	SCONTRO 145X145-12 4F17 105	FLANGE 145X145-12 4F17 105	ANSCHLAG 145X145-12 4F17 105	BUTEE 145X145-12 4F17 105	EL.DE EMPALME 145X145-12 4F17 105	BRIDA 145X145-12 4F17 105
29	R17843580	ASSIEME SUPPORTO	ASSEMBLY SUPPORT	HALTERUNG ZUSAMMENBAU	ASSEMBLEE SUPPORT	ASAMBLEA SUPPORTO	ANSAMBLU SUPORT
30	F20110745	CAV.Q.B=70 M=12X1,75L=96	U-BOLT M12 X PIPE 70X70	BsGELBOLZEN M12 FsR ROHR 70X70	CAVALIER M12 POUR TUBE 70X70	PERNO EN U M12 X TUBO 70X70	BRIDA "U" M12 PT TUB 70X70 ZN
31	F01480055	ROS.G 12,2X 18X2,5 D7980 ZN	GROWER REINF. WASHER D12	VERST. FEDERSCHLEIBE D12	RONDELLE GROWER RENF.D12	ARANDELA GROWER RINF.D12	SAIBA G. 12.2X18X2,5 D7980 ZN
32	R17843540	PIASTRA SUPPORTO	BLADE SUPPORT	MESSER HALTERUNG	LAMA SUPPORT	CUCHILLA SOPORTE	PLACA SUPORT
33	R17843520	INDICATORE SCALA	LEVEL INDICATOR	ANZEIGESKALA	ECHELLE DE L'INDICATEUR	INDICADOR DE ESCALA	INDICATOR SCALA
34	F01020409	VITE M 6X 1X 30 U5739* 8.8 BR	SCREW M6X 1X30 U5739 8.8 BR	SCHRAUBE 6 X30 5739 8.G	VIS 6 X30 5739 8.G	TORNILLO 6 X30 5739 8.G	SURUB M6X 1X30 U5739 8.8 BR
35	F01230022	DADO M 6X 1 D982 8 ZN	NORM.SELF-LOCKING NUT 6 GALVAN	SELBSTSTP. MUTTER NOR.6 ZN	ECROU AUTOB.NOR.6 ZN	TUERCA AUTOB. NOR. 6 ZN	PIULITA AUTOB. NOR. 6 ZN
36	F01020511	VITE M12 X30 U5739	SCREW M12 X30 U5739	VIS M12 X30 U5739	SCHRAUBE M12 X30 U5739	TORNILLO M12 X30 U5739	SURUB M12 X30 U5739
37	R17843500	SCLALA RULLO	LEVEL ROLLER	SKALA ROLLER	ECHELLE ROULEU	ESCALA RODILLO	SCALA RULO
38	F01230144	DADO M24X 3 D982 8 ZN	NUT M24X 3 D982 8 ZN	MUTTER M24X 3 D982 8 ZN	ECROU M24X 3 D982 8 ZN	TUERCA M24X 3 D982 8 ZN	PIULITA M24X 3 D982 8 ZN
39	R17811204	ROTOR RULO 56 DINTI 3M	ROLLER L=3 56 TEETH	WALTZE L=3 56 ZAHN	ROULEAU L=3 56 DENTS	RODILLO L=3 56 DIENTES	RULO L=3 56 DINTI
40	R17811614	ASSIEME PROTEZIONE 3M	ASSEMBLY GUARD 3M	ZUSAMMENBAU SCHUTZ 3M	ASSEMBLEE PROTECTION 3M	ASAMBLEA PROTECCION 3M	ANSAMBLU PROTECTIE 3M

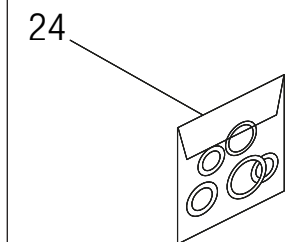

12 ROLLER 250
23 ROLLER 300

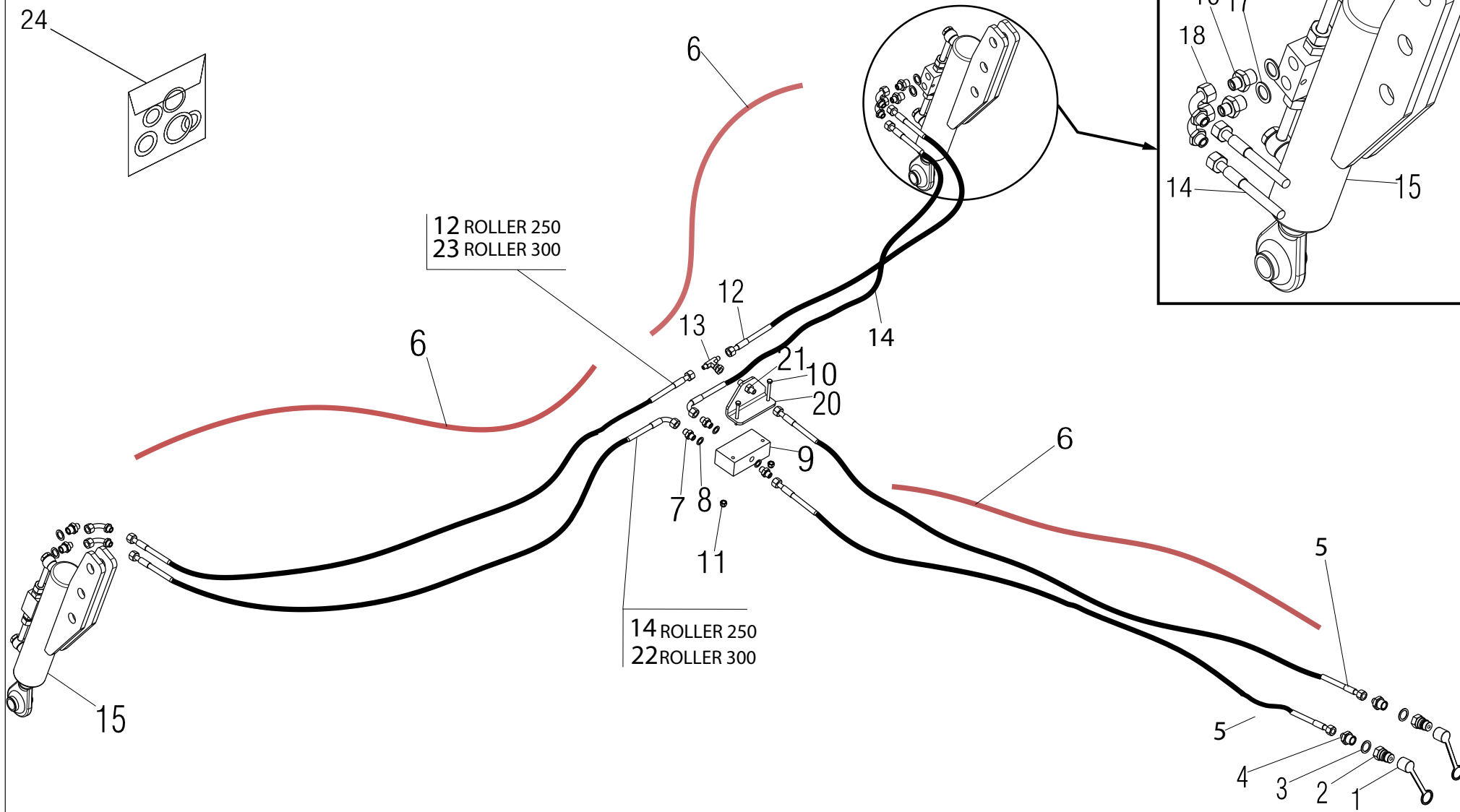
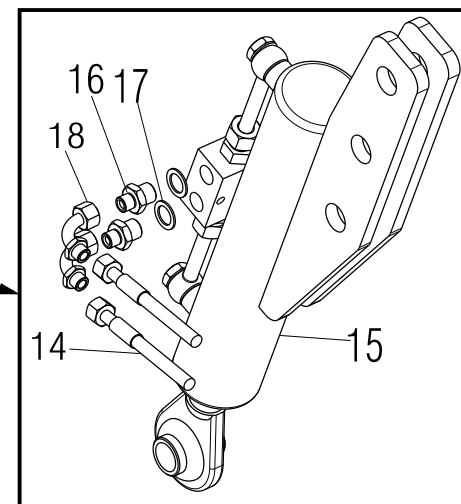

**IMPIANTO OLEODINAMICO / HYDRAULIC PLANT / HYDRAULISCHEN ANZUG / INSTALLATION HYDRAULIQUE / INSTALACION
HIDRAULICA / INSTALAȚIE OLEODINAMICĂ**

TAV. 050

Pos.	Cod.	Descrizione	Description	Benennung	Description	Descripçion	Descriere
1	F05150325	CAPPUC.F X INN.M RAP.1/2 ROSSO	COVER CONNECT F 1/2 RED	DECKEL W 1/2 SCHNELLKUPP. ROT	COUVERCLE CONNEXION F 1/2 ROSE	PAC PROTECCION F 1/2 ROJO	CAPAC PROTECTIE F 1/2 ROSU
2	F03150935	INNESTO RAP.MASCH.1/2 A VALV.	QUICK CONNECT MALE CONE 1/2	SCHNELLKUPP.GEWINDE KONISC 1/2	CONNEXION RAPIDE MALE CONE 1/2	ACOPLAMIEN.RAP.MACHO CONO 1/2	CUPLA RAPIDA TATA 1/2 VALVA
3	F03151237	ROS. 21 X27X1,5 RAME -1/2"	COPPER WASHER 21X27X1,5 1/2	SCHEIBE KUPFER 21X27X1,5 1/2	RONDELLE CUIVRE 21X27X1,5 1/2	ARANDELA COBRE 21X27X1,5 1/2	SAIBA PLANA 21X27X1,5 1/2
4	F03150211	NIPPO MM CIL-CIL 1/2-1/4 ZN	NIPLE MM CIL-CIL 1/4-1/2 ZN	NIPLE GG 1/4-1/2 ZN	NIPLE MM 1/4-1/2 ZN	NIPLE MM 1/4-1/2 ZN	NIPLU MM CIL-CIL 1/4-1/2 ZN
5	R17814480	TUBO 1/4R2 F1/4- F1/4 L=3000	TR 2SN 1/4" FD1/4 FD1/4 3000	TR 2SN 1/4" FD1/4 FD1/4 3000	TR 2SN 1/4" FD1/4 FD1/4 3000	TR 2SN 1/4" FD1/4 FD1/4 3000	TR 2SN 1/4" FD1/4 FD1/4 3000
6	F03100371	GUAINA TELATA D=65 L=3000	SHEATH D=65 L=3000	KABEL D=65 L=3000	GAINA D=65 L=3000	VAINA D=65 L=3000	INVELITOARE PANZA D=65 L=3000
7	F03140266	NIPLO M 1/4" - 1/4"	NIPLE M 1/4" - 1/4"	NIPLE M 1/4" - 1/4"	NIPLE M 1/4" - 1/4"	NIPLE M 1/4" - 1/4"	NIPLU M 1/4" - 1/4"
8	F01500012	RONDELLA IN RAME 1/4"	WASHER 13 X19X1,5 - 1/4"	SCHEIBE	RONDELLE	ARANDELA	SAIBA PLANA 13 X19X1,5 - 1/4"
9	F03151044	DIVISORE DI FLUSSO A 2 VIE	FLOW DIVISOR	OELVERTEILER	DIVISEUR DE FLUX	DIVISOR DE FLUJO	DIVIZOR DE FLUX
10	F01020422	VITE M 6X60	SCREW M 6X60	SCHRAUBE M 6X60	VIS M 6X60	TORNILLO M 6X60	SURUB M 6X60
11	F01220211	DADO TRISTOP M 6	NUT- TRISTOP M 6	MUTTER TRISTOP M 6	ECROU TRISTOP M 6	TUERCA TRISTOP M 6	PIULITA TRISTOP M 6
12	G17915100	TUBO 1/4 R2 F-F L 2800	PIPE 1/4 R2 C-F L 2800	ROHR 1/4 R2 C-F L 2800	TUBE 1/4 R2 C-F L 2800	TUBO 1/4 R2 C-F L 2800	TUB 1/4 R2 C-F L 2800
13	F03151216	RACCORDO -T- MASCHIO 1/4 ZN	MALE T-UNION 1/4 ZN	T VERBINDUNG	CONNECTION A T	JUNTURA A T	RACORD -T- TATA 1/4 ZN
14	G15210551	TUBO 1/4 R2 C-F L 2750	PIPE 1/4 R2 C-F L 2750	ROHR 1/4 R2 C-F L 2750	TUBE 1/4 R2 C-F L 2750	TUBO 1/4 R2 C-F L 2750	TUB 1/4 R2 C-F L 2750
15	R17811482	ASSIEME CILINDRO 30-70-250	CILINDER 30-70-250	ZYLINDER 30-70-250	CYLINDRE 30-70-250	CILINDRO 30-70-250	CILINDRU 30-70-250
16	F03150310	NIPPO MM CIL-CIL 3/8-1/4 ZN	NIPLE MM CIL-CIL 3/8-1/4 ZN	NIPLE MM CIL-CIL 3/8-1/4 ZN	NIPLE MM CIL-CIL 3/8-1/4 ZN	NIPLE MM CIL-CIL 3/8-1/4 ZN	NIPLU MM CIL-CIL 3/8-1/4 ZN
17	F03100023	RONDELLA 3/8"	WASHER 3/8"	SCHEIBE 3/8"	RONDELLE 3/8"	ARANDELA 3/8"	SAIBA 3/8"
18	F03150859	CURVA GIREVOLE 90 F1/4 M1/4 ZN	REVOLVING CURVE 90 F1/4 M1/4 ZN	DREH CURVE 90 F1/4 M1/4 ZN	COURBE RENOUV. 90 F1/4 M1/4 ZN	CURVA GIRATORIA 90 F1/4 M1/4 ZN	COT ROTATIV 90 F1/4 M1/4 ZN
19	F05150058	FASCETTA POLYA 7.8X550 NERA	POLYAMIDE CLAMP 7.8X550 BLACK	POLY. KLAMME 7.8X550 SCHW.	POLY. SERRER 7.8X550 NOIR	POLY ABRAZADERA 7.8X550 NERO	CLEMA POLIAM. 7.8X550 NEAGRA
20	R17641220	PIASTRA SUPPORTO TUBI IDRAUL.	HIDR. TUBE SUPPORT PLATE	HIDR. ROHR UNTERSTÜTZEN PLATTE	PLAQUE DE SUPP. TUBE HIDR.	PLACA SUP. TUBO HIDR.	PLACA SUPORT TUB HIDRAULIC
21	F03020054	PASSAPARETE BSP 1/4 19	NIPLE BSP 1/4 19	NIPLE BSP 1/4 19	NIPLE BSP 1/4 19	NIPLE BSP 1/4 19	NIPLU BSP 1/4 19
22	G15210631	TUBO 1/4 R2 C-F L 3000	PIPE 1/4 R2 C-F L 3000	ROHR 1/4 R2 C-F L 3000	TUBE 1/4 R2 C-F L 3000	TUBO 1/4 R2 C-F L 3000	TUB 1/4 R2 C-F L 3000
23	R17814480	TUBO 1/4 R2 F-F L 3000	PIPE 1/4 R2 C-F L 3000	ROHR 1/4 R2 C-F L 3000	TUBE 1/4 R2 C-F L 3000	TUBO 1/4 R2 C-F L 3000	TUB 1/4 R2 C-F L 3000
24	F03100631	KIT GUARNIZ.	SEAL KIT	DICHTUNGSSATZ	KIT D'ÉTANCHÉITÉ	KIT DE SELLADO	KIT GARNITURI

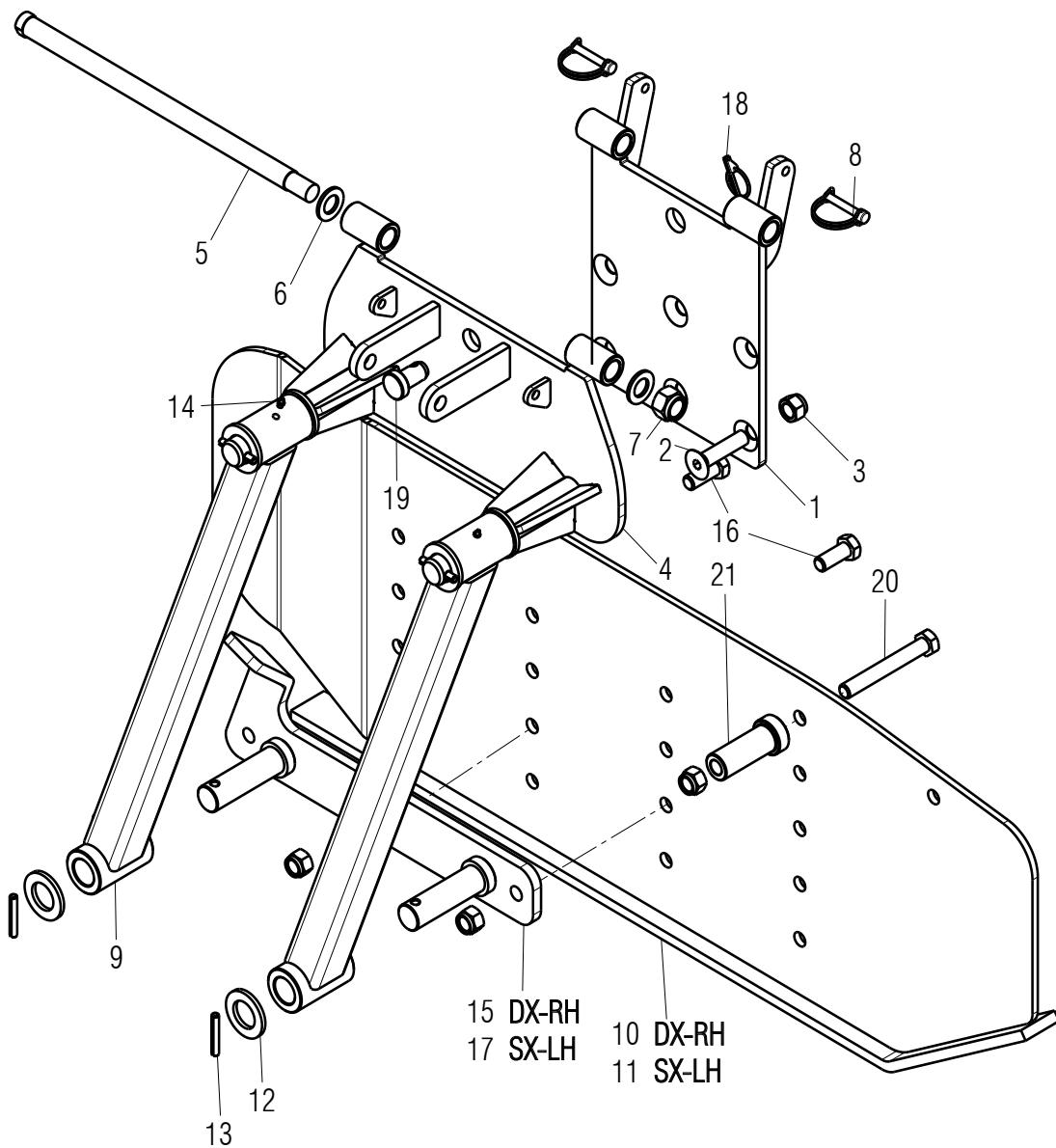

Quando la staffa di regolazione è fissata alle forature 1 - 2 - 3 fissare il finecorsa su foro A

When the adjusting bracket is fixed to the holes of columns 1 - 2 - 3 insert end of stroke pin in hole A

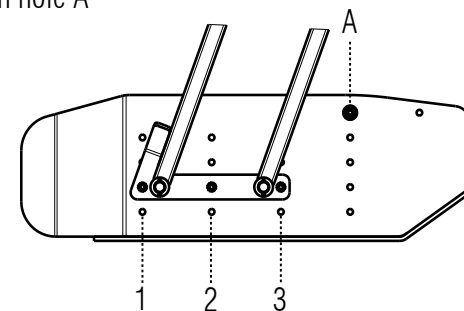

Quando la staffa di regolazione è fissata alle forature 2 - 3 - 4 fissare il finecorsa su foro B

When the adjusting bracket is fixed to the holes of columns 2 - 3 - 4 insert end of stroke pin in hole B

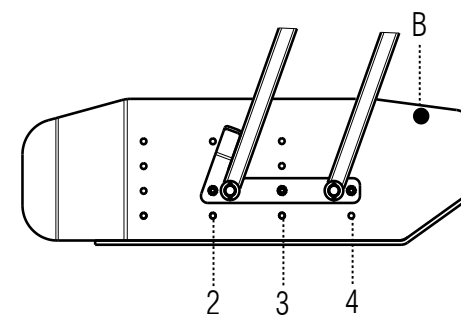

**BANDINELLA LATERALE MECCANICA / MECHANICAL SIDE SHIELD / MECHANISCHE SEITENSCHUTZBLECHS / PROTECION
LATÉRALE MECANIQUE / BANDAS LATERALES MECANICAS / LIMITATOR LATERAL DE BRAZDĂ MECANIC**

TAV. 060

Pos.	Cod.	Descrizione	Description	Benennung	Description	Descripcion	Descriere
1	R17811651	PIASTRA ATTACCO	COUPLING PLATE	MESSER HALTERUNG	LAMA JONCTION	CUCHILLA UNIONE	PLACA PRINDERE
2	F01030152	VITE M16X 2X70 U5933 10.9 ZD	BOLT M16X2X70 U5933 8.8 ZN	SCHRAUBE M16X2X70 U5933 8.8 ZN	VIS M16X2X70 U5933 8.8 ZN	TORNILLO M16X2X70 U5933 8.8 ZN	SURUB M16X 2X 70 U5933 8.8 ZN
3	F01230085	DADO M16X 2 D982 8 ZN	NUT M16X 2 D982 8 ZN	MUTTER M16X 2 D982 8 ZN	ECROU M16X 2 D982 8 ZN	TUERCA M16X 2 D982 8 ZN	PIULITA M16X 2 D982 8 ZN
4	R17811712	ASSIEME RIBALTAMENTO BANDELLE	OVERALL LIMIT UP	ZUSAMMENBAU KLIMMZUG BEGR.	ASSEMBLEE HAUT LIMITER	ASAMBLEA LLEVARSE LIMITADOR	ANSAMBLU RIDICARE LIMITATOR
5	R17811721	PERNO FILETATO D22 M20 L422 ZN	BOLT FILET.D22 M20 L422 ZN	BOLZEN FILET D22 M20 L422 ZN	VIS FILET.D22 M20 L422 ZN	TORNILLO D22 M20 L422 ZN	BOLT FILETAT D22 M20 L422 ZN
6	F01410135	ROS.M22 23X 39X 3 U6592 ZN	WASHER M22 23X39X3 U6592 ZN	SCHIEBE M22 23X39X3 U6592 ZN	RONDELLE M22 23X39X3 U6592 ZN	ARANDELA M22 23X39X3 U6592 ZN	SAIBA M22 23X39X3 U6592 ZN
7	F01220092	DADO M20X 2,5 D980 8 ZN	NUT M20X 2,5 D980 8 ZN	MUTTER M20X 2,5 D980 8 ZN	ECROU M20X 2,5 D980 8 ZN	TUERCA M20X 2,5 D980 8 ZN	PIULITA M20X 2,5 D980 8 ZN
8	F02100312	SPINA DI SICUREZZA D.8X45 ZN	SAFETY PIN D.8X45 ZN	SCHERSTIFT D.8X45 ZN	FICHE EL.DE SECURITE D.8X45 ZN	CLAVIJA DE SEGURIDAD D 8X45 ZN	STIFT RESORT SIGUR. D.8X45 ZN
9	R17613671	ASSIEME LEVA BANDINELLE	OVERALL LIMIT SUPPORT	ZUSAMMENBAU KLIMMZUG BEGR.	ASSEMBLEE HAUT LIMITER	ASAMBLEA LLEVARSE LIMITADOR	ANSAMBLU SUSTINERE LIMITATOR
10	R17613360	ASSIEME LIMITATORE DX	FRAME LEVEL PLATE RH	HALTERUNG EBEN RICHT	ASSEMBLEE NIVEAU DX	ASAMBLEA NIVELADOR DX	ANSAMBLU LIMITATOR DX
11	R17613350	ASSIEME LIMITATORE SX	FRAME LEVEL PLATE LH	HALTERUNG EBEN LINK	ASSEMBLEE NIVEAU SX	ASAMBLEA NIVELADOR SX	ANSAMBLU LIMITATOR SX
12	G20970067	RONDELLA 54X5X32	WASHER 54X5X32	UNTERLEGSCHIEBE 54X5X32	RONDELLE 54X5X32	ARANDELA 54X5X32	SAIBA 54X5X32
13	F02100144	SPINA E.P. 8X 50 U6873 C70 BR	ELASTIC PIN 8X50	SPANNSTIFT D8 L50 D1481 C70BR	FICHE EL. D8 L50 D1481 C70 BR	CLAVIJA D8 L50 D1481 C70 BR	STIFT E.D. D8 L50 D1481 C70 BR
14	F01100048	ING.M 8X1,25 7663A 9SMNPB28 ZN	GREASE NIPPLE M8X1,25 U7663A	SCHMIERBUECHSE M8X1,25 7663A	GRAISSEUR A BILLES M8X1,25	ENGRAS. DE ESFERAS M8 X 1,25 A	GRESOR SFERIC M8X1,25 7663A
15	R17614140	ATTACCO SUPPORTO LIMITATORE SX	COUPL. LEVEL PLATE SUPPORT LH	HALTERUNG ANSCHLUSS EBEN LINK	SUPPORT COUPLE NIVEAU SX	ASAMBLEA UNION NIVELADOR SX	SUPORT PRINDERE LIMITATOR SX
16	F01020252	VITE M16X2X50 U5737 8 8 ZN	BOLT M16X 2X 50 U5737 8.8 ZN	SCHRAUBE M16X2X50 U5737 8.8 ZN	VIS M16X 2X 50 U5737 8.8 ZN	TORNILLO M16X2X50 U5737 8.8 ZN	SURUB M16X 2X 50 U5737 8.8 ZN
17	R17614120	ATTACCO SUPPORTO LIMITATORE DX	COUPL. LEVEL PLATE SUPPORT RH	HALTERUNG ANSCHLUSS EBEN RH	SUPPORT COUPLE NIVEAU DX	ASAMBLEA UNION NIVELADOR DX	SUPORT PRINDERE LIMITATOR DX
18	F02200485	SPINA SCATTO D. 5 B/81 ZN	SNAP PIN D5 B/81 ZN	EINRASTSTIFT D5 B/81 ZN	FICHE A DETENTE D5 B/81 ZN	CLAVIJA DE MUELLE D5 B/81 ZN	STIFT RESORT D5 B/81 ZN
19	R17615130	SPINA D20 L=25 C40 ZN	BOLT D20 L=25 C40 ZN	BOLZEN D20 L=25 C40 ZN	BOULON D20 L=25 C40 ZN	PERNO D20 L=25 C40 ZN	BOLT D20 L=25 C40 ZN
20	F01020266	VITE M16X2X120 U5737 8.8 ZN	BOLT M16X 2X120 U5737 8.8 ZN	SCHR.M16X 2X120 U5737 8.8 ZN	VIS M16X 2X120 U5737 8.8 ZN	TORN.M16X 2X120 U5737 8.8 ZN	SURUB M16X 2X120 U5737 8.8 ZN
21	R17640640	BOCCOLA D40 D30 D16,5 L9	BUSH D40 D30 D16,5 L90 ZN	BUCHSE D40 D30 D16,5 L90 ZN	BUSHING D40 D30 D16,5 L90 ZN	CASQUILLO D40 D30 D16,5 L90 ZN	BUCSA D40 D30 D16,5 L90 ZN

TAV. 070

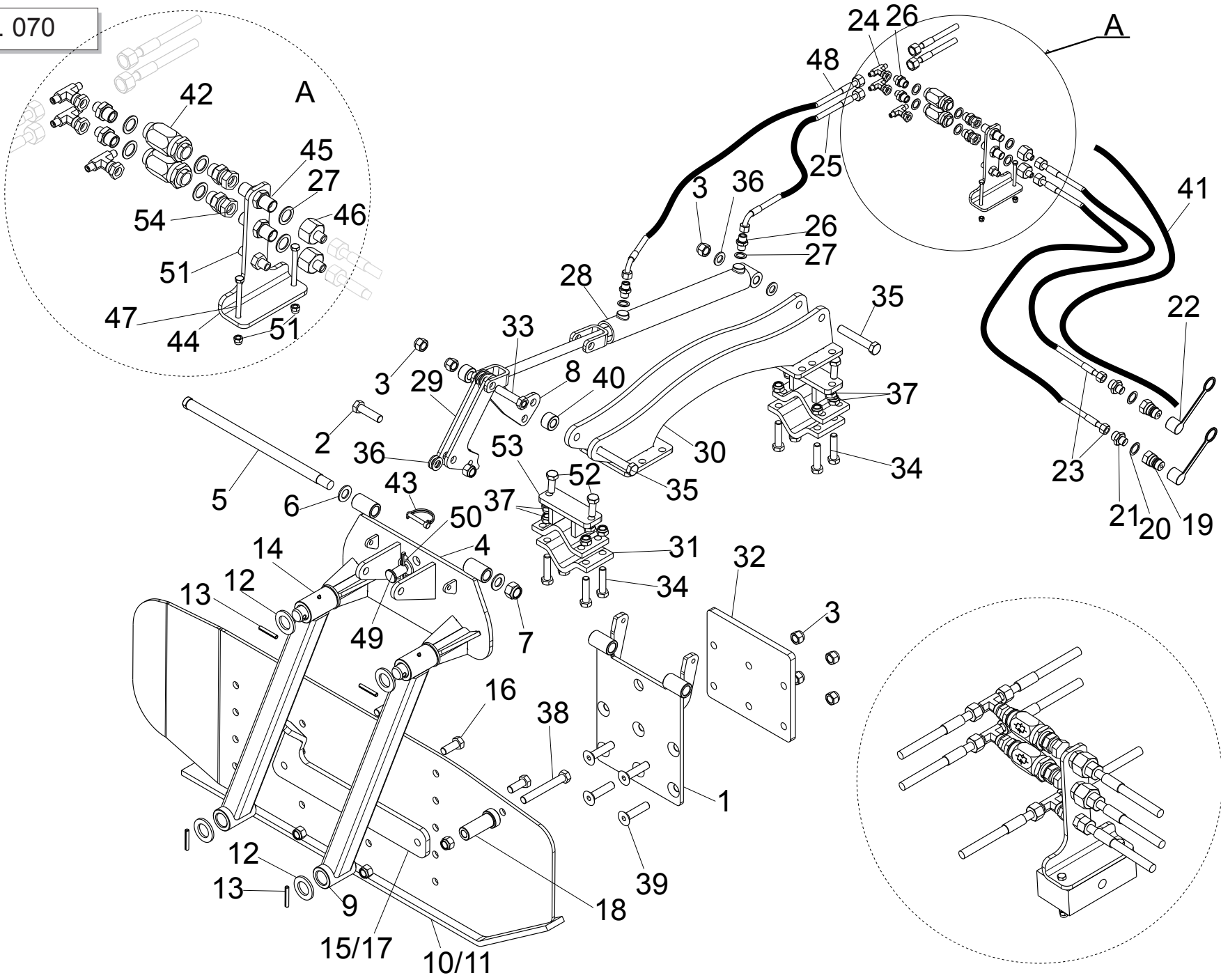

**BANDINELLA LATERALE IDROPNEUMATICA / HYDROPNEUMATIC SIDE SHIELD / HYDROPNEUMATISCHE SEITENSCHUTZBLECHS /
PROTECCION LATÉRAL DE HIDROPNEUMÁTICAS / BANDAS LATERALES HIDROPNEUMÁTICAS / LIMITATOR DE BRAZDĀ**

TAV. 070

Pos.	Cod.	Descrizione	Description	Benennung	Description	Descripcion	Descriere
1	R17811651	ASS.FISSAGGIO BANDINELLA	LIMIT FIXING ASSEMBLY	SUPPORT ANHANGE BEGRENZEN	ASSEMBLEE FIXATION LIMITER	ASAMBLEA FIJACIÓN LIMITADOR	SUPORT FIXARE LIMITATRO BRAZDA
2	F01020256	VITE M16X2X60 U5737 8.8 ZN	BOLT M16X2X60 U5737 8.8 ZN	SCHRAUBE M16X2X60 U5737 8.8 ZN	VIS M16X 2X60 U5737 8.8 ZN	TORNILLO M16X2X60 U5737 8.8 ZN	SURUB M16X 2X60 U5737 8.8 ZN
3	F01230085	DADO M16X 2 D982 8 ZN	NUT M16X 2 D982 8 ZN	MUTTER M16X 2 D982 8 ZN	ECROU M16X 2 D982 8 ZN	TUERCA M16X 2 D982 8 ZN	PIULITA M16X 2 D982 8 ZN
4	R17811712	ASS.FISSAGGIO BANDINELLA	FIXING LIMITER SUPPORT	SUPPORT ANHANGE BEGRENZEN	ASSEMBLEE FIXATION LIMITER	ASAMBLEA FIJACIÓN LIMITADOR	SUPORT FIXARE LIMITATOR BRAZDA
5	R17811721	PERNO FILETATO D22 M20 L422 ZN	BOLT FILET.D22 M20 L422 ZN	BOLZEN FILET D22 M20 L422 ZN	VIS FILET.D22 M20 L422 ZN	TORNILLO D22 M20 L422 ZN	BOLT FILETAT D22 M20 L422 ZN
6	F01410135	ROS.M22 23X 39X 3 U6592 ZN	WASHER M22 23X39X3 U6592 ZN	SCHEIBE M22 23X39X3 U6592 ZN	RONDELLE M22 23X39X3 U6592 ZN	ARANDELA M22 23X39X3 U6592 ZN	SAIBA M22 23X39X3 U6592 ZN
7	F01220092	DADO M20X 2,5 D980 8 ZN	NUT M20X 2,5 D980 8 ZN	MUTTER M20X 2,5 D980 8 ZN	ECROU M20X 2,5 D980 8 ZN	TUERCA M20X 2,5 D980 8 ZN	PIULITA M20X 2,5 D980 8 ZN
8	R17640892	PIASTRA BIELLA	PLATE ROD	STANGE PLATTE	ASSIETE BARRE	BARRA PLATO	PLACA BARA
9	R17613671	ASSIEME LEVA BANDINELLE	BOUNDER PLATE FRAME	HALTERUNG ERHALTUNG EBEN	ASSEMBLEE SUPPORT NIVEAU	ASAMBLEA SOPORTE NIVELADOR	ANSAMBLU SUSTINERE LIMITATOR
10	R17613361	ASSIEME LIMITATORE DX	FRAME LEVEL PLATE RH	HALTERUNG EBEN RICHT	ASSEMBLEE NIVEAU DX	ASAMBLEA NIVELADOR DX	ANSAMBLU LIMITATOR DX
11	R17613351	ASSIEME LIMITATORE SX	FRAME LEVEL PLATE LH	HALTERUNG EBEN LINK	ASSEMBLEE NIVEAU SX	ASAMBLEA NIVELADOR SX	ANSAMBLU LIMITATOR SX
12	G18700670	RONDELLA 54X5X32	WASHER 54X5X32	UNTERLEGSSCHEIBE 54X5X32	RONDELLE 54X5X32	ARANDELA 54X5X32	SAIBA 54X5X32
13	F02100144	SPINA E.P. 8X 50 U6873 C70 BR	ELASTIC PIN 8X50	SPANNSTIFT D8 L50 D1481 C70BR	FICHE EL. D8 L50 D1481 C70 BR	CLAVIJA D8 L50 D1481 C70 BR	STIFT E.D. D8 L50 D1481 C70 BR
14	F01100048	ING.M 8X1,25 7663A 9SMNPB28 ZN	GREASE NIPPLE M8X1,25 U7663A	SCHMIERBUCHSE M8X1,25 7663A	GRAISSEUR A BILLES M8X1,25	ENGRAS. DE ESFERAS M8 X 1,25 A	GRESOR SFERIC M8X1,25 7663A
15	R17614140	ATTACCO SUPPORTO LIMITATORE SX	COUPL. LEVEL PLATE SUPPORT LH	HALTERUNG ANSCHLUSS EBEN LINK	SUPPORT COUPLE NIVEAU SX	ASAMBLEA UNION NIVELADOR SX	SUPORT PRINDERE LIMITATOR SX
16	F01020252	VITE M16X2X50 U5737 8.8 ZN	BOLT M16X 2X 50 U5737 8.8 ZN	SCHRAUBE M16X2X50 U5737 8.8 ZN	VIS M16X 2X 50 U5737 8.8 ZN	TORNILLO M16X2X50 U5737 8.8 ZN	SURUB M16X 2X 50 U5737 8.8 ZN
17	R17614120	ATTACCO SUPPORTO LIMITATORE DX	COUPL. LEVEL PLATE SUPPORT RH	HALTERUNG ANSCHLUSS EBEN RH.	SUPPORT COUPLE NIVEAU DX	ASAMBLEA UNION NIVELADOR DX	SUPORT PRINDERE LIMITATOR DX
18	R17640640	BOCCOLLA D40 D30 D16,5 L90 ZN	BUSHING D40 D30 D16,5 L90 ZN	BUCHSE D40 D30 D16,5 L90 ZN	BUCSA D40 D30 D16,5 L90 ZN	BUCSA D40 D30 D16,5 L90 ZN	BUCSA D40 D30 D16,5 L90 ZN
19	F03150935	INESTO RAPIDO	FAST COUPLING	SCHNELLKUPPLUNG	ATTELAGE RAPIDE	ACOPLE RÁPIDO	CUPLAJ RAPID
20	F03020103	RONDELLA BONDED AUTOCENT 1/2	BONDED WASHER AUTOCENT 1/2	BINDUNGEN SCHEIBE AUTOCENT 1/2	RONDELLE LIE AUTOCENT 1/2	ARANDELA GARANTIZADO AUTO. 1/2	SAIBA INTARITA AUTOCENT 1/2
21	F03150211	NIPPLO MM CIL-CIL 1/2-1/4 ZN	NIPPLE MM CIL-CIL 1/2-1/4 ZN	NIPPEL MM CIL-CIL 1/2-1/4 ZN	NIPPLE MM CIL-CIL 1/2-1/4 ZN	NIPLE MM CIL-CIL 1/2-1/4 ZN	NIPLU MM CIL-CIL 1/2-1/4 ZN
22	F05150325	CAPUCCIO	CAP	DECKEL	CASQUETTE	TAPA	CAPAC
23	F03050862	TUBO 1/4 R2 FG1/4 FG1/4 L2600	TUBE 1/4 R2 FG1/4 FG1/4 L2600	TUBE 1/4 R2 FG1/4 FG1/4 L2600	TUBE 1/4 R2 FG1/4 FG1/4 L2600	TUBO 1/4 R2 FG1/4 FG1/4 L2600	TUB 1/4 R2 FG1/4 FG1/4 L2600
24	F03151216	RACCORDO T 1/4 M-FG-M	CONEXION T 1/4 M-FG-M	ANSCHLUS T 1/4 M-FG-M	FIXATION T 1/4 M-FG-M	RACORDO T 1/4 M-FG-M	RACORD T 1/4 M-FG-M
25	G16011680	TUBO 1/4 R2 CF1/4-F1/4 900	TUBE 1/4 R2 CF1/4-F1/4 900	TUBE 1/4 R2 CF1/4-F1/4 900	TUBE 1/4 R2 CF1/4-F1/4 900	TUBO 1/4 R2 CF1/4-F1/4 900	TUB 1/4 R2 CF1/4-F1/4 900
26	F03150310	NIPPLO 1/4-3/8	NIPPLE 1/4-3/8	NIPPEL 1/4-3/8	NIPPLE 1/4-3/8	NIPLE 1/4-3/8	NIPLU 1/4-3/8
27	F03020070	RONDELLA BONDED AUTOCENT 3/8	BONDED WASHER AUTOCENT 3/8	BINDUNGEN SCHEIBE AUTOCENT 3/8	RONDELLE LIE AUTOCENT 3/8	ARANDELA GARANTIZADO AUTO. 3/8	SAIBA INTARITA AUTOCENT 3/8
28	F03090070	CILINDRO D50 A40 S20 L500 C300	CYLINDER D50 A40 S20 L500 C300	ZYLINDER D50 A40 S20 L500 C300	CYLINDRE D50 A40 S20 L500 C300	CILINDRO D50 A40 S20 L500 C300	CILINDRU D50 A40 S20 L500 C300
29	R17640293	PIASTRA BIELLA	PLATE ROD	PLATTE STANGE	BARRE PLAQUE	PLACA BARRA	PLACA BARA
30	R17819141	ASS. SUPPORTO CILINDRO	CYLINDER SUPPORT ASSEMBLY	UNTERSTÜTZEN ZYLINDER VERS.	ASS. SOUTIEN CYLINDRE	ASAM. APOYO CILINDRO	ANSAMBLU SUPORT CILINDRI
31	R17819110	SCONTRIO	STRIKER PLATE	ANSCHLAG	BUTEE	EL. DE EMPALME	CONTRA GREUTATE
32	R17819200	PIASTRA DISTANZIALE	SPACER PLATE	ZWISCHENRAUM PLATTE	PLAQUE D'ESPACE	PLACA ESPACIADOR	PLACA DISTANTIÈRE
33	F01020260	VITE M16X70 U5737 8.8	SCREW M16X70 U5737 8.8	SCHRAUBE M16X70 U5737 8.8	VIS M16X70 U5737 8.8	TORN. M16X70 U5737 8.8	SURUB M16X70 U5737 8.8
34	F01020205	VITE M14X65 U5737 8.8	SCREW M14X65 U5737 8.8	SCHRAUBE M14X65 U5737 8.8	VIS M14X65 U5737 8.8	TORN. M14X65 U5737 8.8	SURUB M14X65 U5737 8.8
35	F01020285	VITE M16X100 U5737 8.8	SCREW M16X100 U5737 8.8	SCHRAUBE M16X100 U5737 8.8	VIS M16X100 U5737 8.8	TORN. M16X100 U5737 8.8	SURUB M16X100 U5737 8.8
36	F01410100	ROS. M16 17X30X3 U6592 ZN	WASHER M16 17X30X3 U6592 ZN	SCHEIBE M16 17X30X3 U6592 ZN	RONDELLE M16 17X30X3 U6592 ZN	ARANDELA M16 17X30X3 U6592 ZN	SAIBA M16 17X30X3 U6592 ZN
37	F01230073	DADO M16 D982	NUT M16 D982	NUSS M16 D982	ECROU M16 D982	TUERCA M16 D982	PIULITA M16 D982
38	F01020266	VIT. M16X2X120 U5737 8.8 ZN	SCREW M16X2X120 U5737 8.8 ZN	SCHRAUBE M16X2X120 U5737 8.8 ZN	VIS M16X2X120 U5737 8.8 ZN	TORN. M16X2X120 U5737 8.8 ZN	SURUB M16X2X120 U5737 8.8 ZN
39	F01030152	VITE M16X70 U5933 8.8	SCREW M16X70 U5933 8.8	SCHRAUBE M16X70 U5933 8.8	VIS M16X70 U5933 8.8	TORN. M16X70 U5933 8.8	SURUB M16X70 U5933 8.8
40	R17813230	BOCCOLLA	BUSHING	BUCHSE	BUSHE	CASQUILLO	BUCSA
41	F03100383	GUIANA TELATA D=32 L=1750	TEXTILE PROTECTION D=32 L=1750	GEWEBESCHUTZ D=32 L=1750	PROTECTION TEXTILE D=32 L=1750	PROTECCION TEXTIL D=32 L=1750	PROTECTIE TEXTILA D=32 L=1750
42	F02100312	SPINA DI SICUREZZA D8X45 ZN	SAFETY PIN D8X45 ZN	SICHERHEIT STIFT D8X45 ZN	EPINGLE DE SECUR. D8X45 ZN	ALFILER SEGURIDAD D8X45 ZN	BOLT SIGURANTA D8X45 ZN
43	F02200485	SPINA SCATTO D6 SPEC ZN	SNAP PIN D6 SPEC ZN	EINTRASTSTIFT D6 SPEC ZN	FICHE A DETENTE D6 SPEC ZN	EL. DE EMPALME D6 SPEC ZN	STIFT RESORT D6 SPEC ZN
44	R17641120	PIASTRA SUPPORTO	SUPPORT PLATE	UNTERSTÜTZEN PLATTE	PLAQUE SOUTIEN	PLACA DE APOYO	PLACA SUPORT
45	F03020055	PASSAPARETE 3/8-3/8 M	NIPPLE 3/8-3/8 M	NIPPEL 3/8-3/8 M	NIPPLE 3/8-3/8 M	NIPLE 3/8-3/8 M	NIPLU 3/8-3/8 M
46	F03150408	NIPPLO MF CIL-CIL 1/4	NIPPLE MF CIL-CIL 1/4	NIPPEL MF CIL-CIL 1/4	NIPPLE MF CIL-CIL 1/4	NIPLE MF CIL-CIL 1/4	NIPLU MF CIL-CIL 1/4
47	F01020422	VITI M6X1X60 U5739 8.8 ZN	SCREW M6X1X60 U5739 8.8 ZN	SCHRAUBE M6X1X60 U5739 8.8 ZN	VIS M6X1X60 U5739 8.8 ZN	TORN. M6X1X60 U5739 8.8 ZN	SURUB M6X1X60 U5739 8.8 ZN
48	F03050196	TUBO 1/4R2 CF 1/4-F1/4 1335	TUBE 1/4R2 CF 1/4-F1/4 1335	ROHR 1/4R2 CF 1/4-F1/4 1335	TUBE 1/4R2 CF 1/4-F1/4 1335	TUBO 1/4R2 CF 1/4-F1/4 1335	TUB 1/4R2 CF 1/4-F1/4 1335
49	R17614310	PERNO D20 L=35 C40	PIN D20 L=35 C40	BOLZEN D20 L=35 C40	EPINGLE D20 L=35 C40	TORN. D20 L=35 C40	BOLT D20 L=35 C40
50	F02200485	SPINA SCATTO D6 SPEC. ZN	SNAP PIN D6 SPEC. ZN	EINTRASTSTIFT D6 SPEC. ZN	FICHE EL. D6 SPEC. ZN	EL. DE EMPALME D6 SPEC. ZN	RESORT SIGUR. D6 SPEC. ZN
51	F03020054	PASSAPARETE BSP 1/4-19	NIPPLE BSP 1/4-19	NIPPEL BSP 1/4-19	NIPPLE BSP 1/4-19	NIPLE BSP 1/4-19	NIPLU BSP 1/4-19
52	F01020544	VIT. M14X2X40 U5739 8.8 ZN	SCREW M14X2X40 U5739 8.8 ZN	SCHRAUBE M14X2X40 U5739 8.8 ZN	VIS M14X2X40 U5739 8.8 ZN	TORN. M14X2X40 U5739 8.8 ZN	SURUB M14X2X40 U5739 8.8 ZN
53	R17641210	ASSIEME SUPPORTO BANDELLA	SHIELD SUPPORT ASSEMBLY	VERS. UNTERSTÜTZEN SHUTZ	SOUTIEN PROTECCION LATERALE	ASAM. APOYO BANDAS LATERAL.	ANSAMBLU SUPORT BANDINELA
54	F03150067	NIPPLO M-F RUOTARE 3/8 ZN	NIPPLE ROT. M-F 3/8 ZN	NIPPEL DREHER M-F 3/8 ZN	NIPPLE ROT. M-F 3/8 ZN	NIPLE ROT M-F 3/8 ZN	NIPLU ROTITOR M-F 3/8 ZN

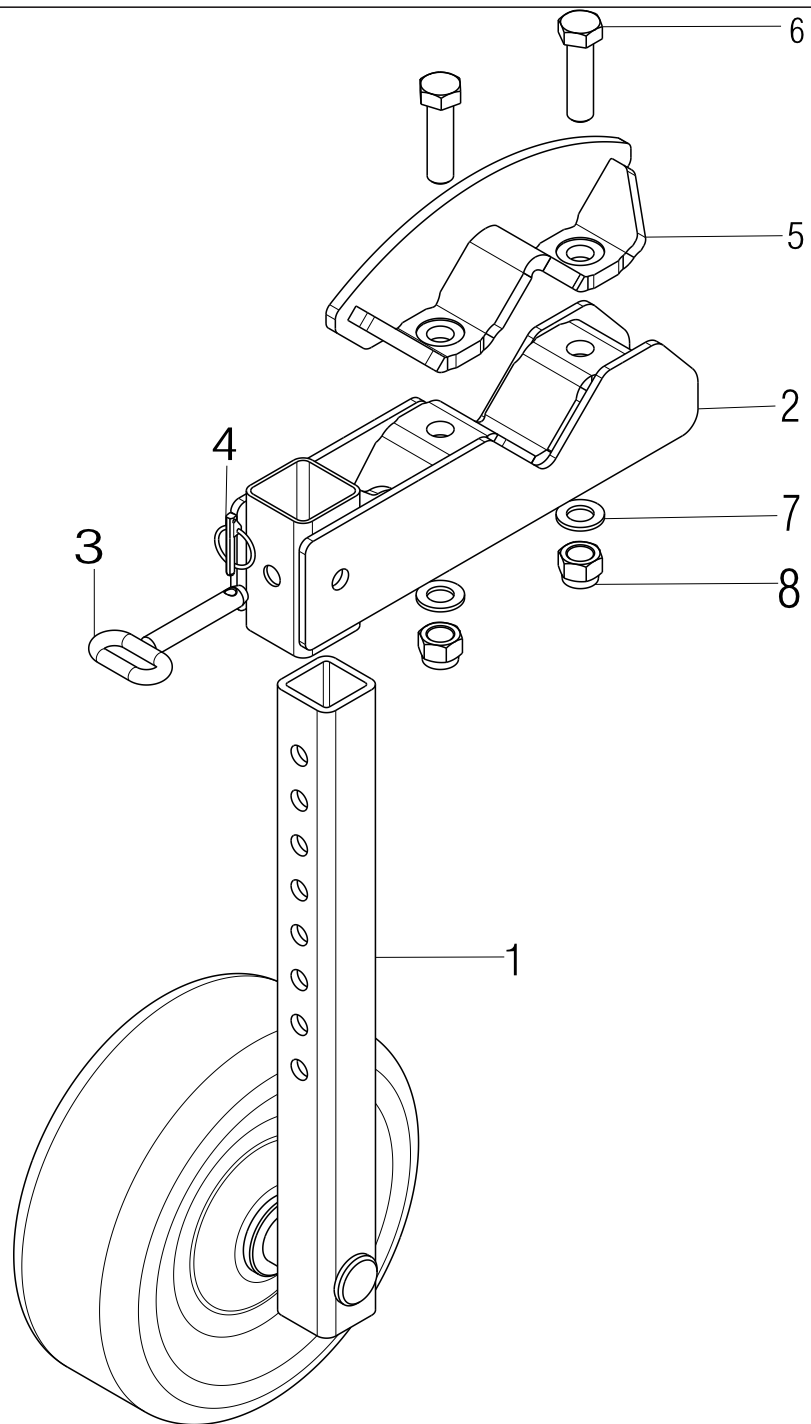

RUOTA DI PROFONDITÀ / DEPTH WHEEL / TIEFENRAD / ROUE DE PROFONDEUR / RUEDA DE PROFUNDIDAD / ROATĂ DE ADÂNCIME

TAV. 080

Pos.	Cod.	Descrizione	Description	Benennung	Description	Descripcion	Descriere
1	R18012160	ASS.RUOTA	ASSEMBLY WHEEL	TIEFENRAD	ASSEMBLEE ROUE	ASAMBLEA RUEDA	ANSAMBLU ROATA
2	R17815722	ASS.SUPPORTO CARPENTERIA	ASSEMBLY SUPPORT	HALTERUNG ZUSAMMENBAU	ASSEMBLE SUPPORT	ASAMBLEA SUPPORTO	ANSAMBLU SUPORT
3	R17810440	ASS.PERNO D20 L105 ZN	BOLT D20 L105 ZN	BOLZEN D20 L105 ZN	BOULON D20 L105 ZN	PERNO D20 L105 ZN	BOLT D20 L105 ZN
4	F02200507	SPINA A SCATTO D 9 B/83	SNAP PIN D9 B/83 ZN	EINRASTSTIFT D9 B/83 ZN	FICHE A DETENTE D9 B/83 ZN	CLAVIJA DE MUELLE D9 B/83 ZN	STIFT RESORT D9 B/83 ZN
5	R17821590	CAVALLOTTO	BRACKET PIPE 100	ANSCHLAG ROHR 100	BRIDE TUBE 100	EL.DE EMPALME TUBO 100	BRIDA TUB 100
6	F01020369	VIT.M24X 3X 90 U5737 10.9 ZB	BOLT M24X 3X 90 U5737 10.9ZB	SCHR. M24X 3X 90 U5737 10.9ZB	VIS M24X 3X 90 U5737 10.9ZB	TORN.M24X 3X 90 U5737 10.9ZB	SURUB M24X 3X 90 U5737 10.9ZB
7	G18701590	RONDELLA 25X35X2,5 ZN	WASHER 25 X35 X2,5 ZN	SCHEIBE 25 X35 X2,5 ZN	RONDELLE 25 X35 X2,5 ZN	ARANDELA 25 X35 X2,5 ZN	SAIBA 25X 35X 2,5 ZN
8	F01230144	DADO M24X 3 D982 8 ZN	NUT M24X 3 D982 8 ZN	MUTTER M24X 3 D982 8 ZN	ECROU M24X 3 D982 8 ZN	TUERCA M24X 3 D982 8 ZN	PIULITA M24X 3 D982 8 ZN

REAR

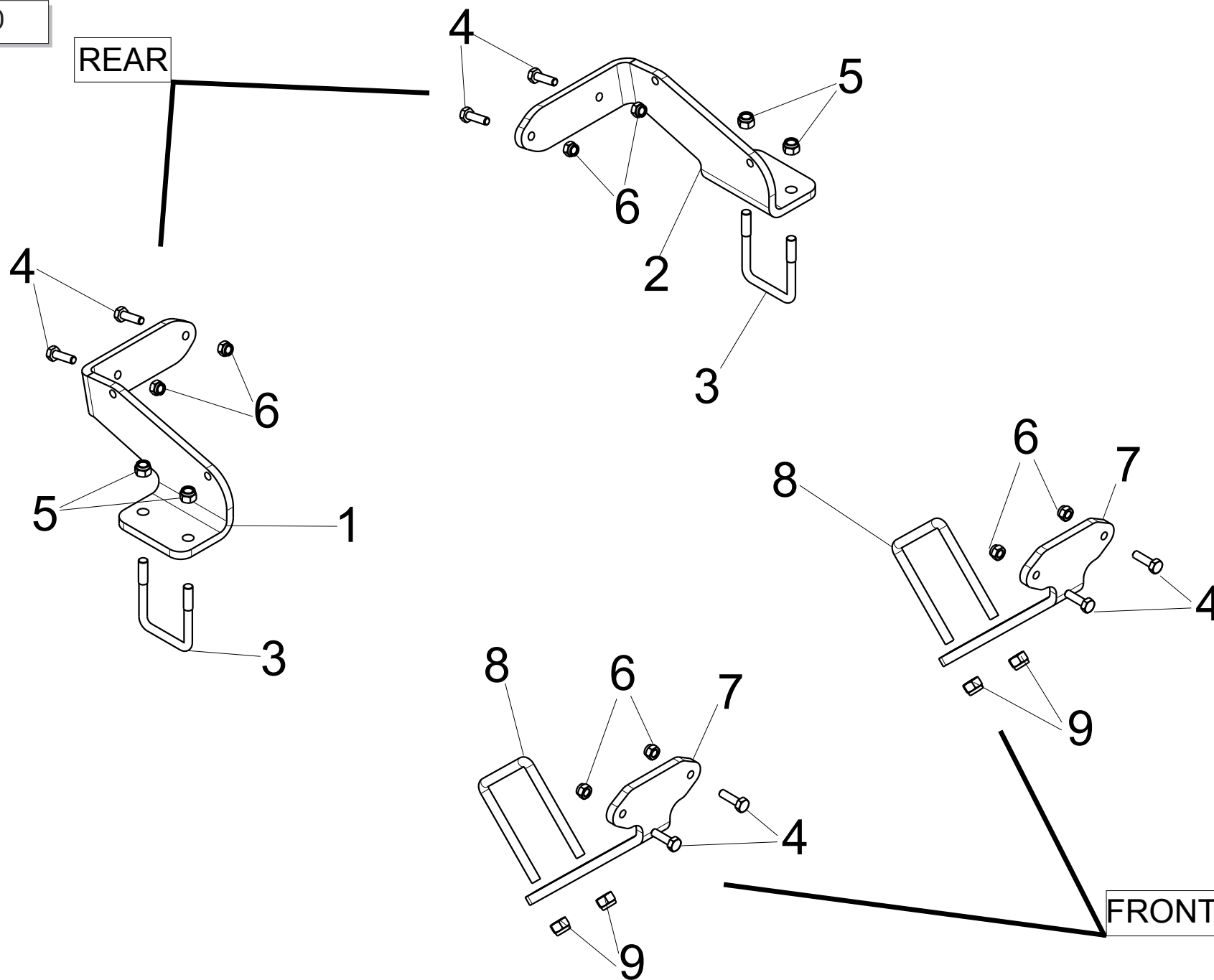

KIT LUCI / LIGHTING KIT / LICHTER KIT / KIT D'ECLAIRAGE / KIT DE ILUMINACION / LIT LUMINI

TAV. 090

Pos.	Cod.	Descrizione	Description	Benennung	Description	Descripcion	Descriere
1	R17617580	PIASTRA SUPP. LUCI	LIGHT SUPPORT PLATE	PLAQUE SUPPORT ECLAIRAGE	LICHTER HALTERUNG PLATTE	PLACA DE SOPORTE ILUMINACION	PLACA SUPORT LUMINI
2	R17617520	PIASTRA SUPP. LUCI	LIGHT SUPPORT PLATE	PLAQUE SUPPORT ECLAIRAGE	LICHTER HALTERUNG PLATTE	PLACA DE SOPORTE ILUMINACION	PLACA SUPORT LUMINI
3	F20110745	CAV. Q. B=70 M=12X1.75 L=96	U BOLT B=70 M=12X1.75 L=96	BRIDE U B=70 M=12X1.75 L=96	ANSCHLANG U B=70 M=12X1.75 L=96	EL. DE EMPALME B=70 M=12X1.75 L=96	BRIDA B=70 M=12X1.75 L=96
4	F01020479	VIT. M10X1.5X35 U5739 8.8 ZN	SCREW M10X1.5X35 U5739 8.8 ZN	VIS M10X1.5X35 U5739 8.8 ZN	SCHRAUBE M10X1.5X35 U5739 8.8 ZN	TORN. M10X1.5X35 U5739 8.8 ZN	SURUB M10X1.5X35 U5739 8.8 ZN
5	F01220048	DADO M12X1.75 D980 8 ZN	NUT M12X1.75 D980 8 ZN	ECROU M12X1.75 D980 8 ZN	NUSS M12X1.75 D980 8 ZN	TUERCA M12X1.75 D980 8 ZN	PIULITA M12X1.75 D980 8 ZN
6	F01220033	DADO M10X1.5 D980 8 ZN	NUT M10X1.5 D980 8 ZN	ECROU M10X1.5 D980 8 ZN	NUSS M10X1.5 D980 8 ZN	TUERCA M10X1.5 D980 8 ZN	PIULITA M10X1.5 D980 8 ZN
7	R17617570	PIASTRA SUPP. LUCI	LIGHT SUPPORT PLATE	PLAQUE SUPPORT ECLAIRAGE	LICHTER HALTERUNG PLATTE	PLACA DE SOPORTE ILUMINACION	PLACA SUPORT LUMINI
8	F20110788	CAV.Q.M14X 2X 50 115X138 ZN	U BOLT M14X 2X 50 115X138 ZN	ANSCHL. U M14X 2X 50 115X138 ZN	BRIDE U M14X 2X 50 115X138 ZN	EL. DE EMP. M14X 2X 50 115X138 ZN	BRIDA U M14X 2X 50 115X138 ZN
9	F01220255	DADO M14X2 D980 8 ZN	NUT M14X2 D980 8 ZN	ECROU M14X2 D980 8 ZN	NUSS M14X2 D980 8 ZN	TUERCA M14X2 D980 8 ZN	PIULITA M14X2 D980 8 ZN

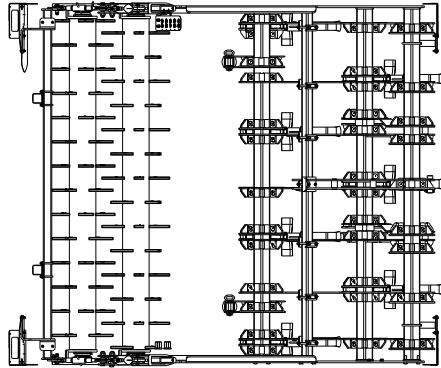
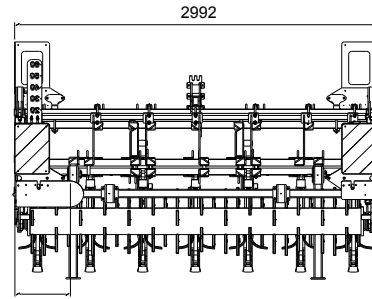
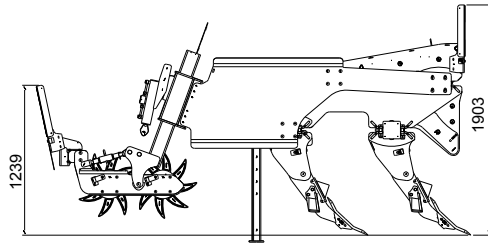

Rullo Idraulico
Hydraulic roller

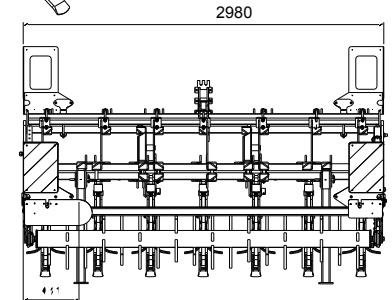
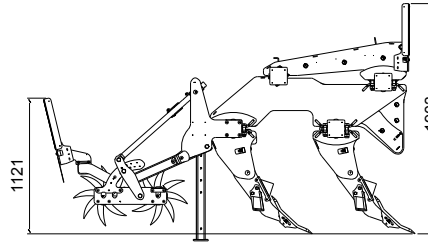
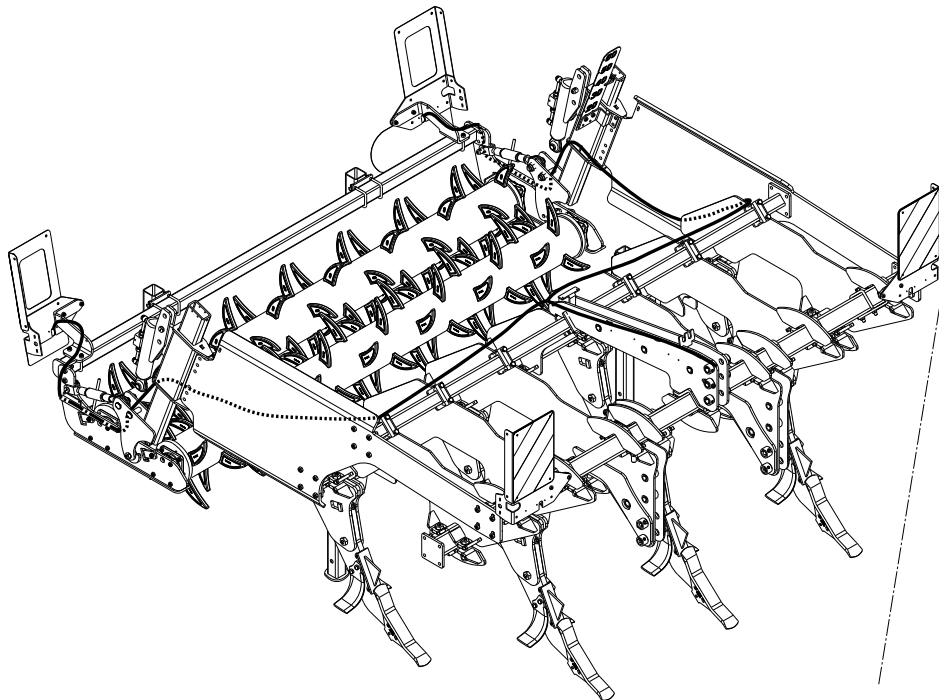

Rullo Meccanico
Mechanical roller

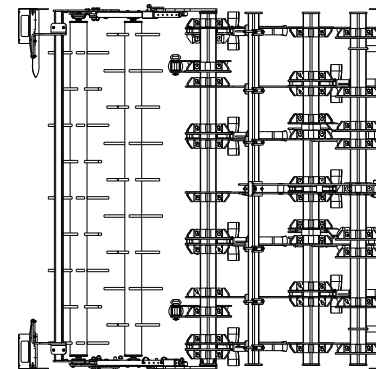

**USATE SEMPRE RICAMBI ORIGINALI
ALWAYS USE ORIGINAL SPARE PARTS
IMMER DIE ORIGINAL-ERSATZTEILE VERWENDEN
EMPLOYEZ TOUJOURS LES PIECES DE RECHANGE ORIGINALES
UTILIZAR SIEMPRE REPUESTOS ORIGINALES
UTILIZAȚI ÎNTOTDEAUNA PIESE DE SCHIMB ORIGINALE**

MASCHIO

GASPARDO

MASCHIO

GASPARDO

MASCHIO GASPARDO S.p.A.

Sede legale e stabilimento produttivo

Via Marcello, 73 - 35011
Campodarsego (PD) Italy
Tel. +39 049 9289810
Fax +39 049 9289900
e-mail: info@maschio.com
www.maschionet.com

MASCHIO DEUTSCHLAND GMBH

Äußere Nürnberger Straße 5
D - 91177 Thalmässing
Deutschland
Tel. +49 (0) 9173 79000
Fax +49 (0) 9173 790079
e-mail: dialog@maschio.de
www.maschionet.com

MASCHIO GASPARDO France S.A.R.L.

1, Rue Denis Papin
45240 La Ferte St. Aubin France
Tel. +33 (0) 2.38.64.12.12
Fax +33 (0) 2.38.64.66.79
e-mail: info@maschio.fr
www.maschionet.com

**MASCHIO GASPARDO North
America, Inc**

112 3rd Avenue East
DeWitt, IA 52742 (USA)
Phone: (563) 659-6400
Fax: (563) 659-6404
info@maschio.us
www.maschionet.com

**MASCHIO GASPARDO (Qingdao)
Agriculture Machinery Co Ltd**

South of 5# Road, Fuyuan Industrial Park,
ETDZ Huangdao - 266500 Qingdao,
Shandong Province, China
Tel: +86 532 86918691
Fax: +86 532 86918690
e-mail: info@maschio.cn
www.maschionet.com

MASCHIO GASPARDO IBERICA S.L.

Ronda General Mitre, 28-30
08017 Barcelona Espana
Tel. +34 93.81.99.058
Fax +34 93.81.99.059
e-mail: info@maschio.es
www.maschionet.com

MASCHIO GASPARDO ROMANIA SRL

Strada Înfrățirii, Nr. 155
315100 Chișineu - Criș
Tel. +40 257 30 70 30
Fax. +40 257 30 70 40
e-mail: info@maschio.ro
www.maschionet.com

ООО МАСКИО-ГАСПАРДО РУССИЯ

404126, Россия, Волгоградская
область,
г.Волжский, ул.Пушкина, 117 *6*.
Тел.: +7 (8443) 203100
факс: +7 (8443) 203101
e-mail: info@maschio.ru
www.maschionet.com

**GASPARDO-MASCHIO TARIM
MAKİNALARI SAN. ve TİC.
LTD. ŞTİ.**

İzmir-Aydın Asfaltı No:39 Yazıbaşı,
Torbalı-İZMİR / TÜRKİYE
Tel: +90 232 8537050
Fax: +90 232 8537385
e-mail: info@maschio.com.tr
www.maschionet.com

**MASCHIO GASPARDO TOB
«МАСКІО – ГАСПАРДО УКРАЇНА»**

04119 Україна, м.Київ, вул. Зоологічна,
4-А, оф.139
Тел. +380 44 538 18 38,
Факс +380 44 538 08 20
e-mail: info@maschio.com.ua
www.maschionet.com

**MASCHIO-GASPARDO POLAND
Sp. z o.o.**

ul. Wapienna 6/8
87-100 Toruń - Polska
Tel. +48 56 650 60 51
Fax +48 56 650 60 53
email: info@maschio.pl
www.gaspardo.pl

**MASCHIO GASPARDO S.p.A.
Production Plant
Morsano al Tagliamento (PN)**

Via Mussons, 7 – 33075 Morsano al Tagliamento
(Pordenone) – Italy
Tel. +39 0434 695410
Fax +39 0434 695425
e-mail: info@gaspardo.it
www.maschionet.com

R19530770

F07011059