

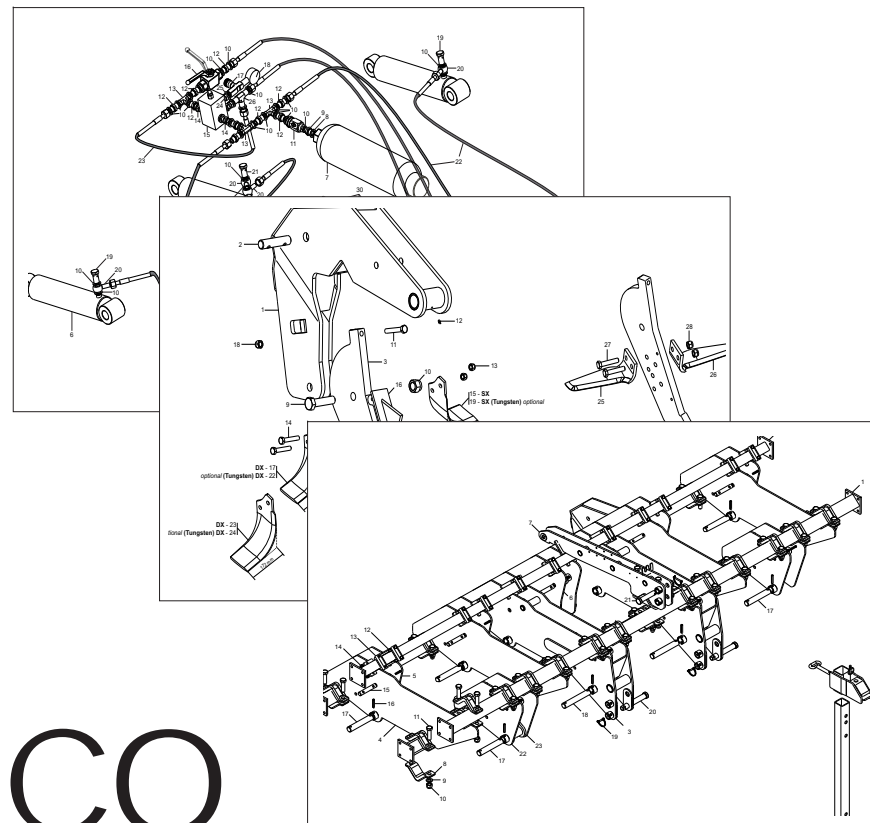

# MASCHIO GASPARDO

## MASCHIO GASPARDO ROMANIA S.R.L.



# ATTILA IDROPNEUMATICO

Cod: R19530120 07 / 2008

- \*) Valido per Paesi UE
- \*) Valid for EU member countries
- \*) Gilt für EU-Mitgliedsländer
- \*) Valable dans le Pays UE
- \*) Válido para Países UE
- \*) Valabil pentru tarile UE

<b>IT</b>	<b>PARTI DI RICAMBIO</b>
<b>EN</b>	<b>SPARE PARTS</b>
<b>DE</b>	<b>ERSATZTEILE</b>
<b>FR</b>	<b>PIECES DÉTACHÉES</b>
<b>ES</b>	<b>PIEZAS DE REPUESTO</b>
<b>RO</b>	<b>PIESE DE SCHIMB</b>

## PARTI DI RICAMBIO

Le ordinazioni delle parti di ricambio vanno fatte presso i nostri concessionari di zona e devono essere sempre corredate dalle seguenti indicazioni:

- **Tipo, modello e numero di matricola dell'attrezzatura.** Tali dati sono stampigliati nell'apposita targhetta di cui è dotata ogni attrezzatura.
  - **Numero di codice della parte richiesta** rilevabile dal catalogo ricambi.
  - **Descrizione del particolare e quantità richiesta.**
  - **Numero della tavola.**
  - **Mezzo di trasporto.** Nel caso questa voce non sia specificata, la Ditta Costruttrice, pur dedicando a questo servizio una particolare cura, non risponde di eventuali ritardi di spedizione dovuti a cause di forza maggiore.
- Le spese di trasporto si intendono sempre a carico del destinatario. La merce viaggia a rischio e pericolo del committente anche se venduta franco destino.

**NOTA:** Il termine **(Dx) Destro** o **(Sx) Sinistro** della macchina o di parti di essa, è inteso guardando la macchina dalla parte posteriore. Le eccezioni saranno indicate.

## SPARE PARTS

*Orders must be transmitted through our area dealers and should always include the following indications:*

- **Type, model and serial number of the machine.** *These data are punched on the data plate with which every implement is equipped.*
- **Code number of the required spare part.** *This will be found in the spare parts catalogue.*
- **Description of the part and required quantity.**
- **Table number.**
- **Means of dispatch.** *If this item is not indicated, the Manufacturer, while dedicating particular care to this service, shall not be held responsible for delays in delivery caused by cases of force majeure.*

*Transport expenses shall always be at the consignee's charge. The goods travel at the purchaser's risk and peril even when sold ex destination.*

**NOTE:** *The symbols (Dx) right and (Sx) left, concerning the machine or single parts of it, are referred, as in the figure, to a rear view of them. Exceptions will be indicated.*

## ERSATZTEILE

Die Bestellungen müssen bei unseren Gebietshändler aufgegeben werden. Bei der Bestellung sind stets die folgenden Angaben zu machen:

- **Typ, Modell und Serien-Nummer des Geräts.** Diese Daten stehen auf dem Typenschild, mit dem jedes Gerät versehen ist.
- **Artikel Nr. der erforderlichen Ersatzteile.** Diese stehen im Ersatzteil-Katalog.
- **Beschreibung des Ersatzteils und die erforderliche Stückzahl.**
- **Tafelnummer.**
- **Versandmittel.** Wenn dieser Punkt nicht spezifiziert wird, haftet die Herstellerfirma nicht für etwaigen Lieferverzug aufgrund höherer Gewalt, auch wenn er diesen Service besonders aufmerksam abwickelt.

Die Frachtkosten gehen dagegen immer zu Lasten des Empfängers. Die Ware reist auf Gefahr und Risiko des Auftraggebers, auch wenn frei Haus Verkauft vereinbart worden ist.

**N.B.:** Die Merkzeichen **(Dx) rechts** und **(Sx) links** betreffen eine rückwärtige Aussicht der Maschine oder Teile von ihr (siehe Bild). Ausnahmen werden gezeigt.

## PIECES DÉTACHÉES

*Les ordres doivent être effectués auprès de nos concessionnaires de zone en précisant les indications suivantes:*

- **Type, modèle et numéro de série de la machine.** *Ces données sont gravées sur la plaque d'identification de chaque outil.*
- **Numéro de code de la pièce détachée** *indiqué sur le catalogue des pièces détachées.*
- **Description de la pièce et quantité requise.**
- **Numéro de plan.**
- **Moyen d'expédition.** *Si cette rubrique n'est pas indiquée, le Constructeur, bien que soucieux de ce service, ne répond pas des retards d'expédition pour des causes de force majeure.*

*Les frais de transport sont toujours à la charge du destinataire. La marchandise voyage aux risques et périls de l'acheteur même si vendue franco de port.*

**N.B.:** *Les références (Dx) droit et (Sx) gauche de la machine ou des parties de la même, est entendue, comme de la figure, en regardant la machine de derriere dans le sens de marche.*

## RESPUESTOS

Los pedidos han de efectuarse en nuestros concesionarios de zona y deben incluir siempre las siguientes indicaciones:

- **Tipo, modelo y número de matrícula del equipo.** Dichos datos están impresos en la relativa placa presente en el equipo.
- **Número de código de la parte requerida** presente en el catálogo respuestas.
- **Descripción de la pieza y cantidad requerida.**
- **Numero de ilustración.**
- **Medio de transporte.** En caso que este ítem no esté especificado, el Fabricante, aún prestando la debidas consideraciones para este aspecto, no responde por eventuales retardos de env'o debidos a causas de fuerza mayor.

Los gastos de transporte se consideran siempre a cargo del destinatario. La mercadería viaja bajo riesgo y peligro del comprador, incluso cuando se vende franco destino.

**N.B.:** La referencia **(Dx) derecha** o **(Sx) izquierda** de la máquina o de sus componentes, se entiende, como en la figura, mirando la máquina por la parte trasera. Se indicarán las excepciones.

## PIESE DE SCHIMB

*Comandarea pieselor de schimb se va face prin intermediul concesionarilor din zonă și trebuie să fie întotdeauna însoțite de următoarele date:*

- **Tipul, modelul și numărul de matricolă al utilajului.** *Aceste date se găsesc pe plăcuța de identificare a fiecărui utilaj.*
- **Numărul de cod al piesei de schimb cerute, care se găsește în manual.**
- **Descrierea piesei de schimb și cantitatea cerută.**
- **Numărul desenului în care se găsește piesa.**
- **Mijloc de transport.** *În cazul în care acesta nu este specificat, Firma Constructoare poate avea un regim special, nu răspunde de eventualele întârzieri de expediere datorate unor cauze de forță majoră.*

*Cheltuielile de transport sunt suportate de destinatar. Marfa este transportată pe riscul celui care efectuează comanda, chiar dacă marfa este vândută în condiții franco-destinatare.*

**NOTA:** *Termenul (Dx) Dreapta sau (Sx) Stânga a utilajului sau a părților acestuia, este privind utilajul din partea posterioară. Excepțiile vor fi indicate.*

<b><i>Nr. Tav.</i></b>	<b><i>Descrizione - Description</i></b>	<b><i>Pag.</i></b>
TAV. 010	Telaio	4
TAV. 020	Ancora	6
TAV. 030	Impianto idropneumatico	8
TAV. 040	Rullo oleodinamico	10
TAV. 050	Impianto oleodinamico rullo	12
TAV. 060	Doppio rullo posteriore meccanico	14
TAV. 070	Bandinelle laterali	16
TAV. 080	Ruote di sostegno	18
TAV. 090	Kit luci	20

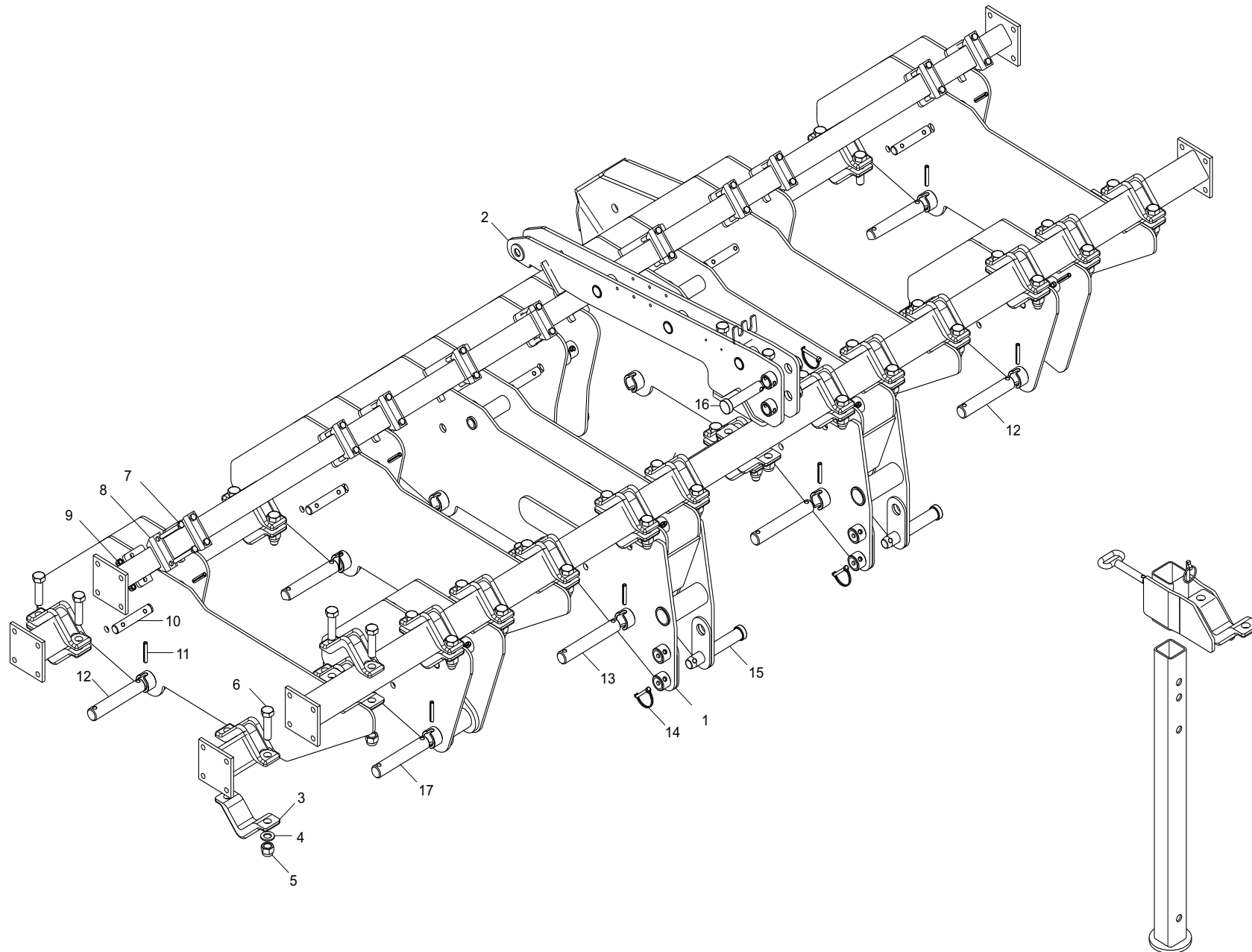

**TELAIO**

**TAV. 010**

Pos.	Cod.	Descrizione	Description	Description	Benennung	Descripcion	Descriere
1	R17815521	ASSIEME TELAIO CENTRALE	ANS. CENTRAL FRAME	ANS. CH-SIS CENTRAL	HALTERUNG	ANS. BASTIDOR	ANS.SASIU CENTRAL
2	R17814171	ASS.TERZO PUNTO ARTIGLIO HIDRO	ANS. SUPPORT 3P ARTIGLIO HIDRO	ANS. SUPPORT 3P ARTIGLIO HIDRO	HALTERUNG 3P ARTIGLIO HIDRO	ANS. SOPORTE 3P ARTIGLIO HIDRO	ANS.SUPORT SASIU 3PART.HIDRO
3	R17811170	SCONTRIO PER TUBO 100	STRIKER PLATE 100	BUTEE 100	ANSCHLAG 100	ELEMENTO DE EMPALME 100	BRIDA FIXARE TEAVA 100
4	G18701590	RONDELLA 25X35X2.5 ZB	WASHER 25 x 35 x2.5 ZB	RONDELLE 25 x 35 x2.5 ZB	UNTERLEGSCHIEBE 25 x 35 x2.5	ARANDELA 25 x 35 x2.5 ZB	SAIBA 25X35X2.5 ZB
5	F01230144	DADO M24X 3 D982 8 ZN	SELF-LOCKING NUT NORM.24 ZB	ECROU AUTOB.NORM.24 ZB	SELBSTSPERR. MUTTER NORM.24 ZB	TUERCA AUTOB. NORM.24 ZB	PIUL.M24X 3 D982 8 ZN
6	F01020343	VITE M24X 3X 80 U5737 10.9 ZD	BOLT M24X 3X 80 U5737 10.9 ZB	VIS M24X 3X 80 U5737 10.9 ZB	SCHR.M24X 3X 80 U5737 10.9 ZB	TORN.M24X 3X 80 U5737 10.9 ZB	SUR. M24X 3X 80 U5737 10.9 ZB
7	F01020174	VITE M12X1,75X120 5737 8.8 ZN	BOLT 12X120 5737 8.8 GALVANIZ.	VIS 12X120 5737 8.8 ZN	SCHRAUBE 12X120 5737 8.8 ZN	TORNILLO 12X120 5737 8.8 ZN	SUR. M12X1,75X120 5737 8.8 ZB
8	G16740160	SCONTRIO A U SP.8 2F13 83	U-SHAPED STOP TEETH B343SP8	BUTEE EN U SP.8 2F13 83	U-ANSCHLAG SP.8 2F13 83	DIENTE DE PARADA A U ESP.8	BRIDA U SP.8 2F13 83
9	F01230059	DADO M12X1,75 D982 8 ZB	NUT M12X1,75 D982 8 ZB	ECRO.M12X1,75 D982 8 ZB	MUTT.M12X1,75 D982 8 ZB	TUER.M12X1,75 D982 8 ZB	PIUL.M12X1,75 D982 8 ZB
10	R17814070	PERNO	PIN	PIVOT	BOLZEN	PERNO	BOLT
11	F02100180	SPINA E.P. 12X 70 U6873 C70 BR	ELASTIC PIN 12X70 DIN 1481	GOUJON ELASTIQUE 12X70	SPANNHUELSE 12x70 DIN 1481	ESPINA ELASTICA 12X70 DIN 1481	SPIN (stift) ELASTIC 12X70 UN
12	R17814080	PERNO	PIN	PIVOT	BOLZEN	PERNO	BOLT
13	R17816570	SPINA D40 L220 ZB	PIN D40 L220 ZB	BROCHE D40 L220 ZB	STIFT D40 L220 ZB	CLAVIJA D40 L220 ZB	STIFT D40 L220 ZB
14	F02200584	SPINA SICUR. D. 12X70 ZN	GALVAN. SAFETY PIND.12X70	GOUPILLE DE S+CURIT+ D.12X70 Z	SCHERSTIFT D.12X70 ZN	PASADOR DE SEGURIDAD D 12X70 Z	STIFT DE SIGURANTAD.12X70 ZN
15	R17816580	SPINA D36 ZB	PIN D36 ZB	BROCHE D36 ZB	STIFT D36 ZB	CLAVIJA D36 ZB	STIFT D36 ZB
16	F20100101	PERNO D32 L128 C43 ZN	PIN GASPARD0 32X134 ZN	BROCHE GASPARD0 32X134 ZN	STIFT GASPARD0 32X134 ZN	CLAVIJA GASPARD0 32X134 ZN	STIFT GASPARD0 32X134 ZN

TAV. 020

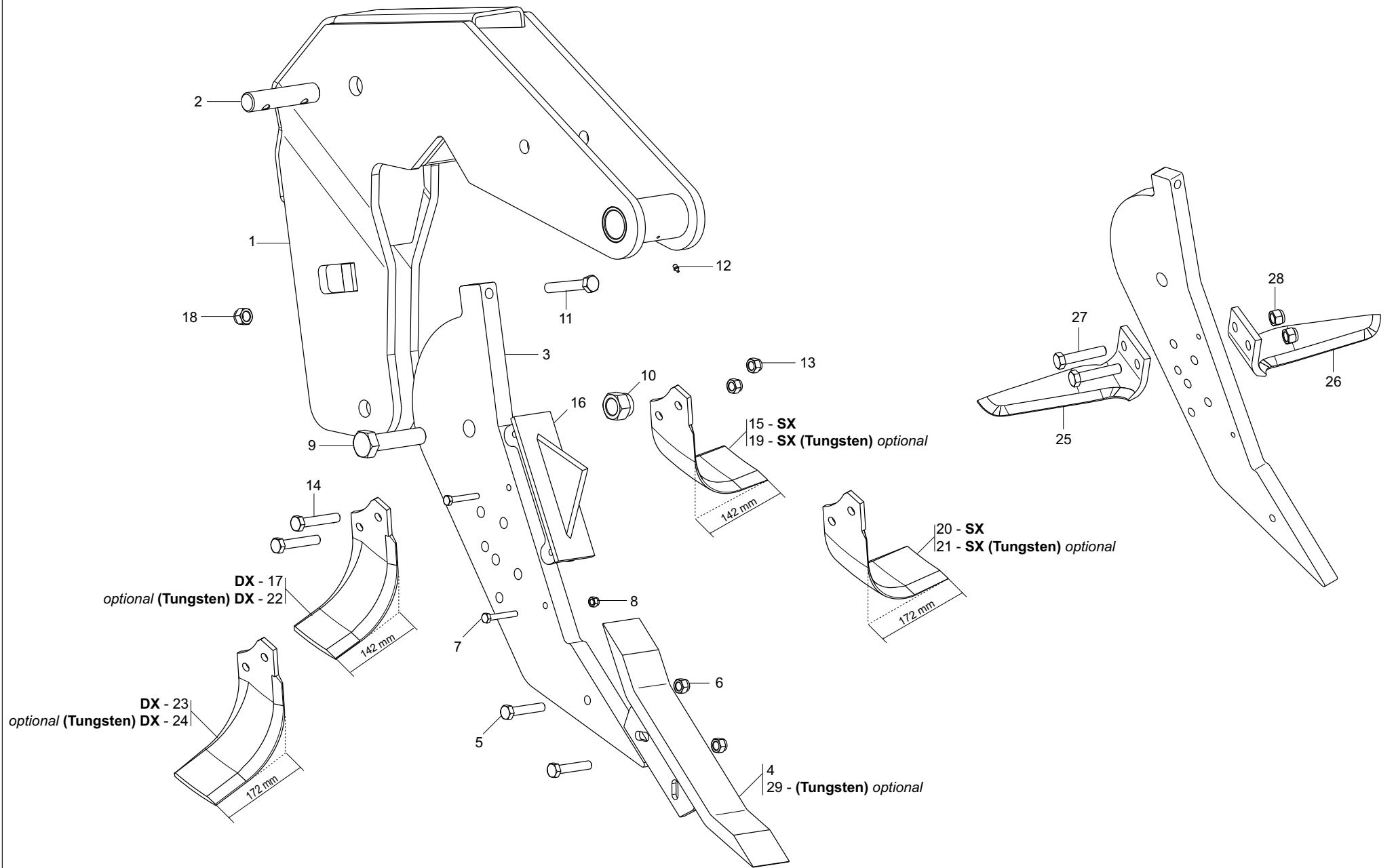

Pos.	Cod.	Descrizione	Description	Description	Benennung	Descripcion	Descriere
1	R17817150	SUPPORTO PUNTALE ATTILA	SUPPORT FOR EARTH-OPENING BLAD	SUPPORT EMBOUT ATTILA	MESSERHALTERATTILA	SOPORTE PUNTALATTILA	ANS.SUSTINERE VARFATTILA
2	R17814060	PERNO	PIN	GOUJON	BOLTZEN	PERNO	BOLT
3	R17820561	LAMA	BLADE	LAME	MESSER	CUCHILLA	LAMA PROPTITOR
4	R17820681	ASSIEME DENTE	POINT ATTILA-PIN RAPID-REVERSI	ANS. DENT	ZINKEN	DIENTE ATTILA	ANSAMBLU DINTE ATTILA
5	F01020164	VITE M12X1,75X70 U5737 8.8 ZB	BOLT M12X1,75X70 U5737 8.8 ZB	VIS M12X1,75X70 U5737 8.8 ZB	SCHR.M12X1,75X70 U5737 8.8 ZB	TORN.M12X1,75X70 U5737 8.8 ZB	SUR. M12X1,75X70 U5737 8.8 ZB
6	F01230059	DADO M12X1,75 D982 8 ZB	NUT M12X1,75 D982 8 ZB	ECRO.M12X1,75 D982 8 ZB	MUTT.M12X1,75 D982 8 ZB	TUER.M12X1,75 D982 8 ZB	PIUL.M12X1,75 D982 8 ZB
7	F01020075	VITE M8X1,25X55 U5737 8.8 ZN	BOLT 8 X55 5737 8.8 GALVANIZED	VIS 8 X55 5737 8.8 ZN	SCHRAUBE 8 X55 5737 8.8 ZN	TORNILLO 8 X55 5737 8.8 ZN	SUR. M8X1,25X55 U5737 8.8 ZB
8	F01230034	DADO M 8X1,25 D982 8	SELF LOCKING NUT M8X1,25	ECROU AUTOBL. M8X1,25	SELBSTSP.MUTT. M8X1,25	DADO AUTOBL. M8X1,25	PIULITA AUT.M8X1,25 D982 8G ZB
9	F01020344	VITE M24X 3X100 U5737 10.9 ZD	SCREW 24X100 5737 10.9 ZN	VIS 24X100 5737 10.9 ZN	SCHRAUBE 24X100 5737 10.9 ZN	TORNILLO 24X100 5737 10.9 ZN	SUR. M24X100 5737 10.9 ZN
10	F01230144	DADO M24X 3 D982 8 ZN	SELF-LOCKING NUT NORM.24 ZB	ECROU AUTOB.NORM.24 ZB	SELBSTSPERR. MUTTER NORM.24 ZB	TUERCA AUTOB .NORM.24 ZB	PIUL.M24X 3 D982 8 ZN
11	F01020212	VITE M14X 2X 90 U5737 8.8 ZB	BOLT M14X 2X 90 U5737 8.8 ZB	VIS M14X 2X 90 U5737 8.8 ZB	SCHARUBE M14X2X 90 U5737 8.8 ZB	TORNILLO M14X 2X 90 U5737 8.8	SURUB M14X 2X 90 U5737 8.8 ZB
12	F01100011	ING.M6X1 7663-A9SMNPB28 ZN	SPHERE NIPPLE M6X1/A	GRAISSEUR A BILLES M6X1/A	KUGELFETTBSCHSE M6X1/A	ENGRAS. DE ESFERAS M6X1/A	ING.M6X1 7663-A9SMNPB28 ZB
13	F01230073	PIULITA AUT.AM14X2 D982 8G Z	SELF LOCKING NUT M14X2	ECROU AUTOBL. M14X2	SELBSTSP.MUTT. M14X2	DADO AUTOBL. M14X2	PIULITA AUT.AM14X2 D982 8G Z
14	F01020210	VITE M14X 2X 80 U5737 8.8 ZG	BOLT M14X 2X 80 U5737 8.8 ZG	VIS M14X 2X 80 U5737 8.8 ZG	SCHRAUBE M14X 2X 80 U5737 8.8	TORNILLO M14X 2X 80 U5737 8.8	SUR. M14X2 X 80 5737 8.8 ZB
15	M74100436	ZAPPAAD ELICA SINISTRA S=10	LEFT C BLADES (THICKNESS 10)	LAME HELICE GCH	BOGENMESSER SX	AZADA HELICE SX	SAPAE LICOIDALA STANGA
16	R17820411	ASSIEME SUPORTO LAMA	ANS. SUPPORT BLADE	ASS. SUPPORT LAMA	MESSERHALTERUNG	ANS. CUCHILLA SOPORTE	ANSAMBLU LAMA SUPORTE
17	M74100435	ZAPPAAD ELICA DESTRA S=10	RIGHT C BLADES (THICKNESS 10)	LAME HELICE DRT	RECHTES BOGENMESSER	AZADA HELICE DERECHA	SAPAE LICOIDALA DREAPTA
18	F01260046	DADO FLANG.M14 D6923 8.8 ZN	NUT M14 D6923 8.8 ZB	ECROU M14 D6923 8.8 ZB	MUTTER M14 D6923 8.8 ZB	TUERCA M14 D6923 8.8 B	PIULITA FLANG.M14 D6923 8.8 ZB
19	R17820870	ZAPPAAD ELICA SX TUNGSTEN	LEFT HELICOIDAL BLADE TUNGSTEN	LAME HELICE B-C-SC GCH TG	LINKES BOGENMESSER TG	AZADA HELICE IZQUIERDA TUNGSTE	SAPAE LICE SX TUNGSTEN
20	R17820820	ZAPPAELICA SINISTRA	RIGHT HELICOIDAL BLADE	LAME HELICE B-C-SC GCH	RECHTES BOGENMESSER	AZADA HELICE DERECHA	SAPASX
21	R17820890	ZAPPAAD ELICA SX P30 TUNGSTEN	LEFT HELICOIDAL BLADE P30 TG	LAME HELICE B-C-SC GCH P30 TG	LINKES BOGENMESSER SX P30 TG	AZADA HELICE IZQUIERDA P30 TG	SAPAE LICE SX P30 TUNGSTEN
22	R17820860	ZAPPAAD ELICA DESTRA TG	RIGHT C BLADES TG	LAME HELICE DRT	RECHTES BOGENMESSER TG	AZADA HELICE DERECHA TG	SAPAE LICOIDALA DREAPTA TG
23	R17820830	ZAPPA ELICA DESTRA P30	RIGHT HELICOIDAL BLADE P30	LAME HELICE B-C-SC DRT P30	RECHTES BOGENMESSER P30	AZADA HELICE DERECHA P30	SAPAAAD ELICE DX P30
24	R17820880	ZAPPA ELICA DESTRA TG P30	RIGHT HELICOIDAL BLADE TG P30	LAME HELICE B-C-SC DRT TG P30	RECHTES BOGENMESSER TUNG. P30	AZADA HELICE DERECHA TG P30	SAPAAAD ELICE DX TUNGSTEN P30
25	M27100210	COLTELLO DC/DS/DL DX 90X12	CLOCKWISE BLADE	COUTEAU DC-BR-CPR 12MM DRT	RECHTES MESSER	CUCHILLO DERECHO	CUTTIT DREAPTA
26	M27100209	COLTELLO DC/DS/DL SX 90X12	COUNTERCLOCKWISE BLADE	COUTEAU DC-BR-CPR 12MM GCH	LINKES MESSER	CUCHILLO IZQUIERDO	CUTTIT STINGA
27	F01020263	VITE 16X80 5737 8.G *	SCREW 16X80 5737 8.G	VIS 16X80 5737 8.G *	SCHRAUBE 16X80 5737 8.G	TORNILLO 16X80 5737 8.G	SURUB M16X 2X 80 U5737 8.8
28	F01230085	DADO M16X 2 D982 8 ZB	NUT M16X 2 D982 8 ZB	ECROU M16X 2 D982 8 ZB	MUTT.M16X 2 D982 8 ZB	TUER.M16X 2 D982 8 ZB	PIUL.M16X 2 D982 8 ZB
29	R17820731	ASS. DENTE TG	ANS. TOOTH TG	ANS. DENT TG	ZINKEN TG	DIENTE TG ATTILA	ANSAMBLU DINTE TG

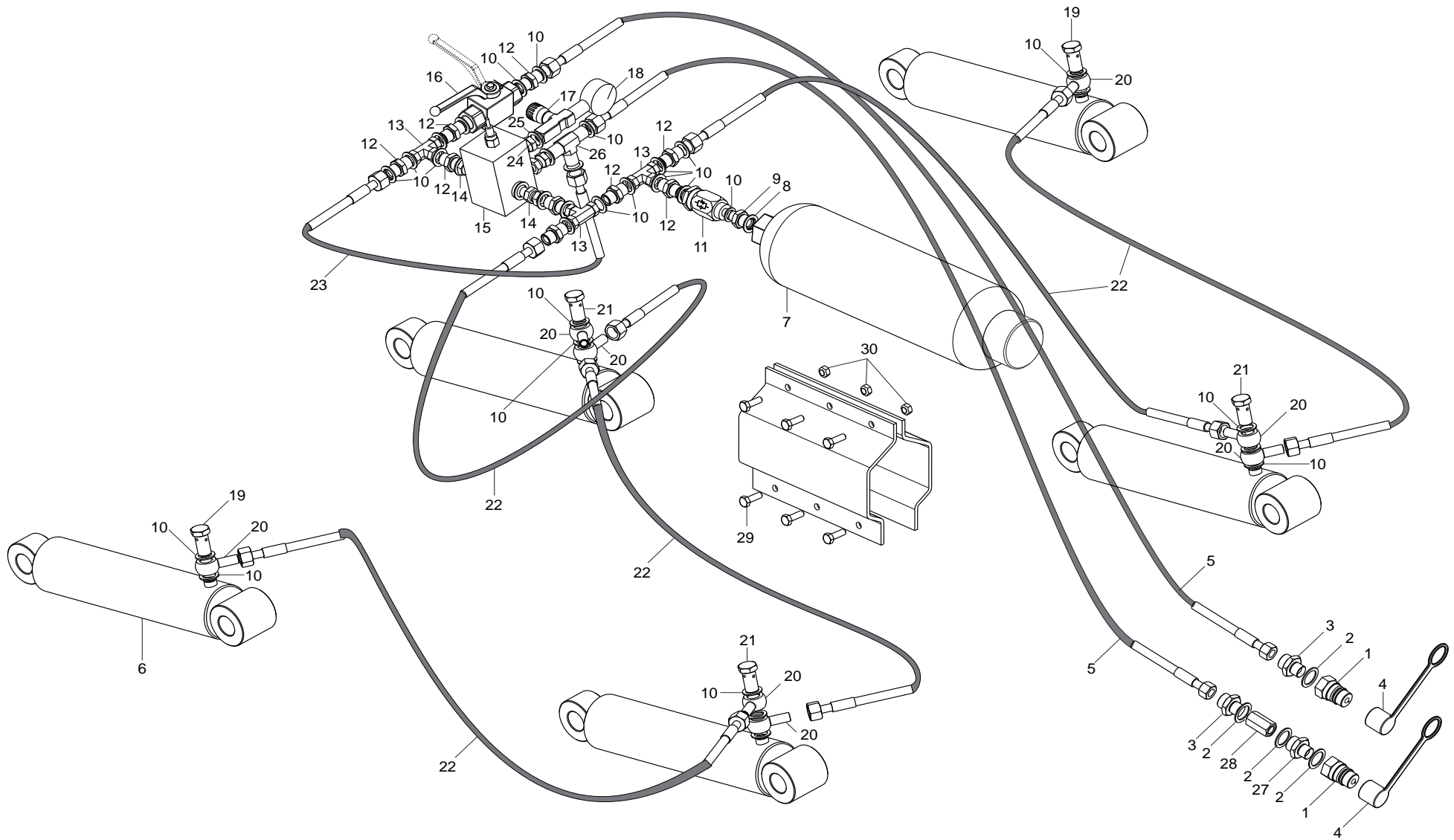



# IMPIANTO IDROPNEUMATICO

TAV. 030

Pos.	Cod.	Descrizione	Description	Description	Benennung	Descripcion	Descriere
1	F03150935	INNESTO RAP.MASCH.1/2A VALV.	QUICK CONNECT MALE CONE 1/2 CO	CONNEXION RAPIDE MALE CONE 1/2	SCHNELLKUPPLUNG GEWINDE KONISC	ACOPLAMIENTO RAPIDO MACHO CONO	CONECTARE RAPIDA TATA.CU 1/2
2	F03151237	RONDELLA RAME 21X27X1,5 -1/2"	1/2 COPPER WASHER	RONDELLE CUIVRE 1/2	UNTERLEGSCHIBE KUPFER 1/2	ARANDELA COBRE 1/2	SAIBA RAME 1/2
3	F03150222	NIPPLO MM CIL-CIL 1/2-3/8 ZB	NIPPLE MM CIL-CIL 1/2-3/8 ZB	NIPPLE MM CIL-CIL 1/2-3/8 ZB	NIPPEL MM CIL-CIL 1/2-3/8 ZB	NIPLE MM CIL-CIL 1/2-3/8 ZB	NIPLU MM CIL-CIL 1/2-3/8 ZB
4	F05150325	CAPPUCCIO PROT.INNESTO RAP.1/2	COVER 1/2	COUVERCLE 1/2	DECKEL 1/2	TAPA 1/2	GLUGA CONECTARE 1/2
5	G15312601	TUBO 3/8 R2 F3/8-F3/8 L.2000	PIPE 3/8 R2 F3/8-F3/8 L.2000	TUBE 3/8 R2 F3/8-F3/8 L.2000	ROHR 3/8 R2 F3/8-F3/8 L.2000	TUBO 3/8 R2 F3/8-F3/8 L.2000	TUB 3/8 R2 F3/8-F3/8 L.2000
6	R17814560	CILINDRO	CYLINDER	CYLINDER	ZYLINDER	CILINDRO	CILINDRU
7	F03151265	ACCUMULATORE 2,8L 250 BAR	ACCUMULATOR 2,8L 250 BAR	ACCUMULATEUR 2,8L 250BAR	AKKUMULATOR 2,8L 250BAR	ACUMULADOR 2,8L 250BAR	ACUMULATOR AZOT 2,8L 250BAR
8	F03151239	RONDELLA RAME 3/4	3/4 COPPER WASHER	RONDELLE CUIVRE 3/4	UNTERLEGSCHIBE KUPFER 3/4	ARANDELA COBRE 3/4	SAIBA RAME 3/4
9	F03150011	NIPPLO 3/4" - 3/8"	NIPPLE 3/4" - 3/8"	NIPPLE 3/4" - 3/8"	NIPPEL 3/4" - 3/8"	NIPLE 3/4" - 3/8"	NIPLU 3/4" - 3/8"
10	F03151240	RONDELLA RAME 3/8	3/8 COPPER WASHER	RONDELLE CUIVRE 3/8	UNTERLEGSCHIBE KUPFER 3/8	ARANDELA COBRE 3/8	SAIBA RAME 3/8
11	F03151252	STROZZATORE BIDIREZ.VSRB 3/8	BI-DIRECTIONAL VENTURI 3/8	ETRANGLEUR BIDIRECTIONN. 3/8	ZWEIS. DROSSEL	ESTRANGULADOR BIDIRECCIONAL 3/8	GITUIRE BIDIRECTIONALA 3/8
12	F03150321	NIPPLO MM CIL-CIL 3/8-3/8 ZG	NIPPLE- GALVAN. CYLINDR.MALE-	NIPPLE MALE 3/8-MALE 3/8	NIPPEL 3/8- 3/8	NIPLA MACHO 3/8-MACHO 3/8	NIPLU TATA 3/8-TATA 3/8
13	F03151266	RACCORDO-T-FEMMINA 3/8 ZN	CONNECTION T- F 3/8 ZN	RACCORD-T-F 3/8 ZN	ANSCHLUSS-T- F 3/8 ZN	RACOR-T- F 3/8 ZN	RACORD-T- MAMA 3/8 ZINC.
14	F03150067	NIPPLO MF GIREVOLE 3/8 ZG CIL	NIPPLE M-F SWIVEL 3/8 ZINC.	NIPPLE M-F TOURNANT 3/8 ZING.	NIPPEL M-F DREHBAR 3/8 VERZINK	NIPLE M-H GIRATORIO 3/8 CINC.	NIPLU M-F ROTITOR 3/8 ZINC.
15	F03150593	VALVOLA VMP 3/8	VALVE VMP 3/8	SOUPAPE VMP 3/8	VENTIL VMP 3/8	VULA VMP 3/8	VALVA VMP 3/8
16	F03151246	RUBINETTO F-F 3/8	BREATHER TAP F-F 3/8	BOUCHON REFOUL. F-F 3/8	ENTLsFTUNGSPFROPFEN F-F 3/8	TAPON PURGADOR F-F 3/8	ROBINET F-F 3/8
17	F03151267	RUBINETTO 1/4	COCK 1/4	BOUCHON REFOUL 1/4	HAHN 1/4	TAPON PURGADOR 1/4	ROBINET 1/4
18	F03151164	MANOMETRO B.G. DA 0 A 250 BAR	PRESSURE GAUGE B.G.0-250 BAR	MANOMETRE B.G. 0-250 BAR	MANOMETER B.G. DA 0 A 250 BAR	MANMETRO B.G. 0-250 BAR	MANOMETRU B.G. 0-250 BAR
19	F03151223	RACCORDO VITE CAVA 3/8	UNION BOLT HOLLOW 3/8	RACCORD VIS CREUSE 3/8	ANSCHLUSS GEWINDEHOHLSCHR.3/8	UNIN TORNILLO RANURA 3/8 R	ACORD SURUB CAVA 3/8 R
20	F03151269	OCCHIONE FILETATO 3/8 - 3/8	EYE FIL. 3/8 - 3/8	OEIL FILET. 3/8 - 3/8	AUGE FIL. 3/8 - 3/8	OJO FILETATO 3/8 - 3/8	OCHI FILETAT 3/8-3/8
21	F03151224	RACCORDO VITE CAVA 3/8 8 FORI	UNION BOLT HOLLOW 3/8	RACCORD VIS CREUSE 3/8	ANSCHLUSS GEWINDEHOHLSCHR.3/8	UNIN TORNILLO RANURA 3/8 R	RACORD SURUB 3/8 8 GAURI
22	R17814610	TUBO 3/8 R2 F3/8-F3/8 L.1650	TUBE 3/8 R2 F3/8-F3/8 L.1650	TUBE 3/8 R2 F3/8-F3/8 L.1650	ROHR 3/8 R2 F3/8 - F3/8 L.1650	TUBO 3/8 R2 F3/8-F3/8 L.1650	TUB 3/8 R2 F3/8-F3/8 L.1650
23	G15316320	TUBO SAE 100 R2 F-F 3/8 L.900	PIPE SAE 100 R2 F-F 3/8 L.900	TUBE SAE 100 R2 F-F 3/8 L.900	ROHR SAE 100 R2 F-F 3/8 L.900	TUBO SAE 100 R2 F-F 3/8 L.900	TUB SAE 100 R2 F-F 3/8 L.900
24	F03151268	RIDUZIONE 3/8"M - 1/4"F	REDUCTION 3/8"M - 1/4"F	CONNECTION PIPE 3/8"M - 1/4"F	REDUKTIONM 3/8"M - 1/4"F	REDUCCION 3/8"M-1/4"F	REDUCTIE 3/8"M - 1/4"F
25	F03151238	RONDELLA RAME 13X19X1,5 -1/4"	1/4 COPPER WASHER	RONDELLE CUIVRE 1/4	UNTERLEGSCHIBE KUPFER 1/4	ARANDELA COBRE 1/4	SAIBA RAME 1/4
26	F03151220	RACCORDO -T- MASCHIO 3/8 ZN	MALE T-UNION 3/8 ZINC.	RACCORD -T- MALE 3/8 ZING.	ANSCHLUSSTsCK -T- GEWINDE 3/8	UNIN -T- MACHO 3/8 CINC. R	ACORD -T- TATA 3/8 ZINC. R
27	F03150255	NIPPLO MASCH.CIL.1/2-1/2 ZN	NIPLE 1/2"GAS	NIPLE 1/2"GAS	NIPLE 1/2"GAS	NIPLE 1/2"GAS	NIPLU 1/2" GAS
28	F03150576	VALVOLA UNID.IN LINEA 1/2	UNIDIRECTIONAL VALVE 1/2'	SOUPAPE UNIDIRECTIONNELLE 1/2'	SPERVENTIL 1/2'	VæLVULA UNIDIRECCINAL 1/2" V	ALVA UNIDIRECTIONALA 1/2" R
29	F01020440	VITE M8X1,25X25 U5739 8.8 ZN	BOLT M8 X25 5739 8.8 ZN	VIS M8 X25 5739 8.8 ZN	SCHRAUBE M8 X25 5739 8.8 ZN	TORNILLO M8 X25 5739 8.8 ZN	SURUB TE.8GM8X25 UNI 5739
30	F01220022	DADO M8X1,25 D980 8 ZG	SELF LOCKING NUT M8X1,25 980V	ECROU AUTOBL. M8X1,25 980-V	SELBSTSP.MUTT. M8X1,25 980-V	DADO AUTOBL. M8X1,25 980-V	PIULITAAUTOFRINARE M8X1,25 U

TAV. 040

MOD. 2008

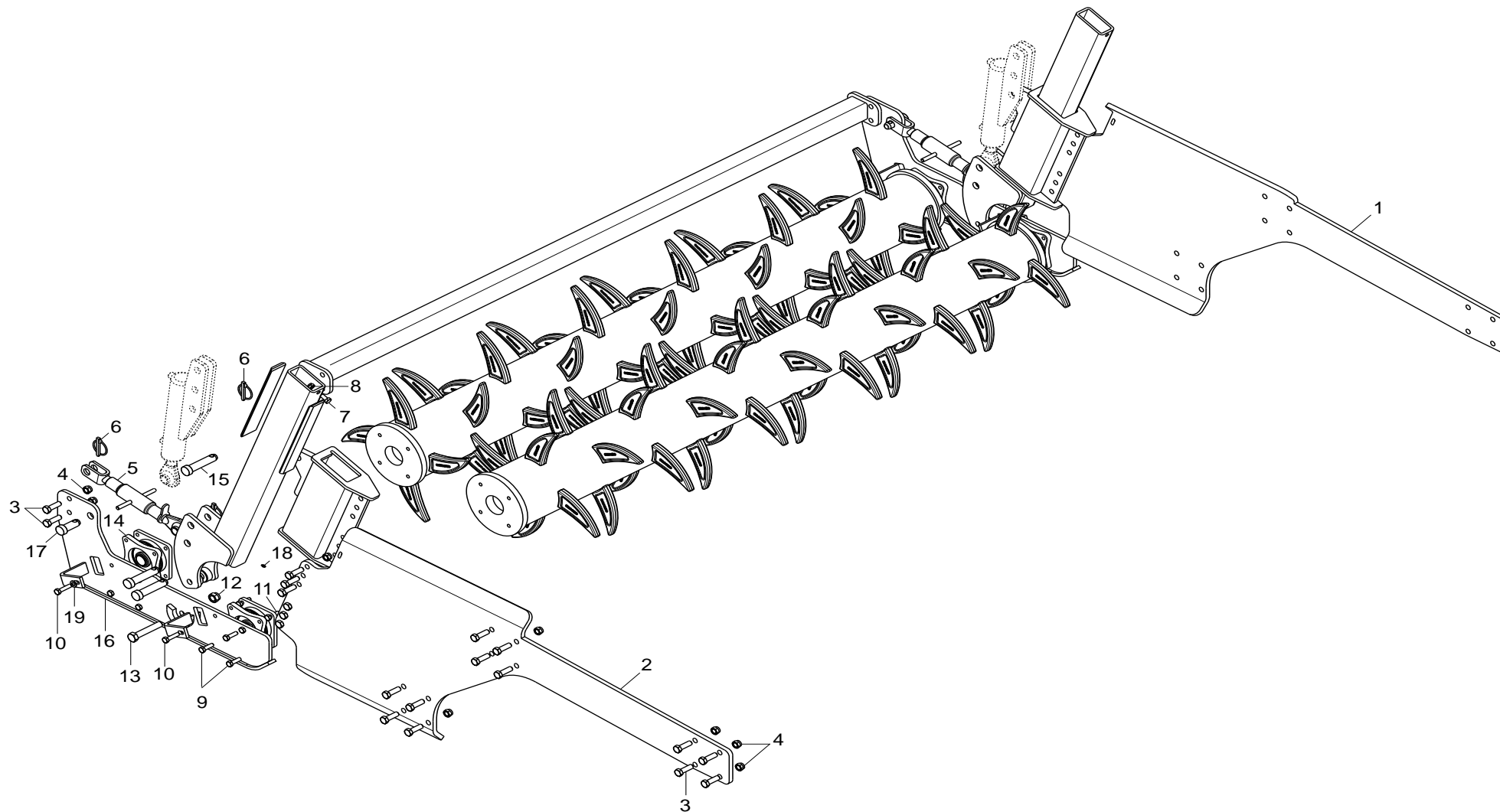

# RULLO OLEODINAMICO

TAV. 040

Pos.	Cod.	Descrizione	Description	Description	Benennung	Descripcion	Descriere
1	R17815761	LAMA SUPPORTO REGOLAZIONE SX	SUPPORT BLADE ADJUSTMENT SX	SUPPORT LAME REGLAGE SX	HALTERUNG MESSER SX	CUCHILLA SOPORTE SX	LAMA SUPORT REGLARE SX
2	R17815751	PIASTRA SOPORTO REGOLAZIONE DX	RIGHT BLADE SUPPORT	LAMA SUPPORT DROIT	MESSER SUPPORT DX	CUCHILLA SOPORTO DX	LAMA SUPORT REGLARE DX
3	F01020252	VITE M16X 2X50 U5737 8.8 ZB	BOLT M16X 2X50 U5737 8.8 ZB	VIS M16X 2X50 U5737 8.8 ZB	SCHR.M16X 2X50 U5737 8.8 ZB	TORN.M16X 2X50 U5737 8.8 ZB	SUR. M16X 2X50 U5737 8.8 ZB
4	F01230085	DADO M16X 2 D982 8 ZB	NUT M16X 2 D982 8 ZB	ECROU M16X 2 D982 8 ZB	MUTT.M16X 2 D982 8 ZB	TUER.M16X 2 D982 8 ZB	PIUL.M16X 2 D982 8 ZB
5	F02450022	CILINDRO L=330 L=490 D25,4 ZD	CYLINDER L=330 L=490 D25,4 ZD	CYLINDRE L=330 L=490 D=25,4 ZD	ZYLINDER L=330 L=490 D=25,4 ZD	CILINDRO L=330 L=490 D25,4 ZD	CILINDRU L=330 L=490 D=25,4 ZD
6	F02200507	SPINA SCATTO D. 9 B/83 ZN	SNAP PIN D 9 B/83	FICHE A DETENTE D 9 B/83	EINRASTSTIFT D 9 B/83	CLAVIJADE MUELLE D 9 B/83	STIFT RESORT D 9 ZB B/83
7	F01020508	VITE M12X1,75X25 U5739 8.8 ZN	BOLT M 12X25	VIS M 12 X 25	SCHRAUBE M 12 X 25	TORNILLO M 12 X 25	SURUB M12X1,75X25 5739 8.8 ZN
8	F01230059	DADO M12X1,75 D982 8 ZB	NUT M12X1,75 D982 8 ZB	ECRO.M12X1,75 D982 8 ZB	MUTT.M12X1,75 D982 8 ZB	TUER.M12X1,75 D982 8 ZB	PIUL.M12X1,75 D982 8 ZB
9	F01010288	VITE M12X1,25X35 U5740 8.8 ZN	SCREWM12X1,25X35 U5740 8.8 ZB	VIS M12X1,25X35 U5740 8.8 ZB	SCHR.M12X1,25X35 U5740 8.8 ZB	TORN.M12X1,25X35 U5740 8.8 ZB	SUR. M12X1,25X35 U5740 8.8 ZB
10	F01010292	VITE M12X1,25X45 U5740 8.8 ZG	BOLT M12X1,25X45 U5740 8.8 ZG	VISM12X1,25X45 U5740 8.8 ZG	SCHRAUBE M12X1,25X45 U5740 8.8 ZG	TORNILLO M12X1,25X45 U5740 8.8 ZB	SUR. M12X1,25X45 U5740 8.8 ZB
11	F01020528	VITE M12X1,75X40 U5739 10.9 ZD	SCREW 12X40 5739 10.9 ZN	VIS 12X40 5739 10.9 ZN	SCHRAUBE 12X40 5739 10.9 ZN	TORNILLO 12X40 5739 10.9 ZN	SURUB 12X40 5739 10.9 ZN
12	F01230131	DADO M20X 2,5 D982 6 ZB	NUT M20X 2,5 D982 6 ZB	ECRO.M20X 2,5 D982 6 ZB	MUTT.M20X 2,5 D982 6 ZB	TUER.M20X 2,5 D982 6 ZB	PIUL.M20X 2,5 D982 6 ZB
13	F01020313	VITE M20X2,5X110 U5737 8.8 ZN	BOLT 20X110 5737 8.8 GALVANIZ.	VIS 20X110 5737 8.8 ZN	SCHRAUBE 20X110 5737 8.8 ZN	TORNILLO 20X110 5737 8.8 ZN	SURUB 20X110 5737 8.8 ZN
14	R17015300	ASSIEME CUSCINETTO	BEARING SUPPORT	SUPPORT ROULEMENT	LAGERHALTERUNG	SOPORTE COJINETE	ANSAMBLU LAGAR
15	F20100063	PERNO D25 L91 C40 ZN	PIN GASPARDO D25 L113 C40	PIVOT GASPARDO D25 L113 C40	BOLZEN GASPARDO D25 L113 C40	PERNO GASPARDO D25 L113 C40	BOLT GASPARDO D25 L113 C40
16	R17811403	ASS. SUPPORTO RULLO	FRAME ROLLER	SUPPORT ROULEAU	ROLLE HALTERUNG	SOPORTE RODILLO	ANS. SUPORT RULO
17	R17817910	PERNO ZB	PIN ZB	PIVOT ZB	BOLZEN ZB	PERNO ZB	BOLT ZB
18	F01100011	ING.M 6X1 7663-A9SMNPB28 ZN	SPHERE NIPPLE M6X1/A	GRAISSEUR A BILLES M6X1/A	KUGELFETTBSCHSE M6X1/A	ENGRAS. DE ESFERAS M6X1/A	ING.M 6X1 7663-A9SMNPB28 ZN
19	F01410076	RONDELLA D12 UNI 6592 ZN	PLANE WASHER D12 UNI 6592 ZN	RONDELLE D12 UNI 6592 ZN	SCHEIBE D12 UNI 6592 ZN	ARANDELA D12 UNI 6592 ZN	SAIBA PLANA D12 UNI 6592 ZB

TAV. 050

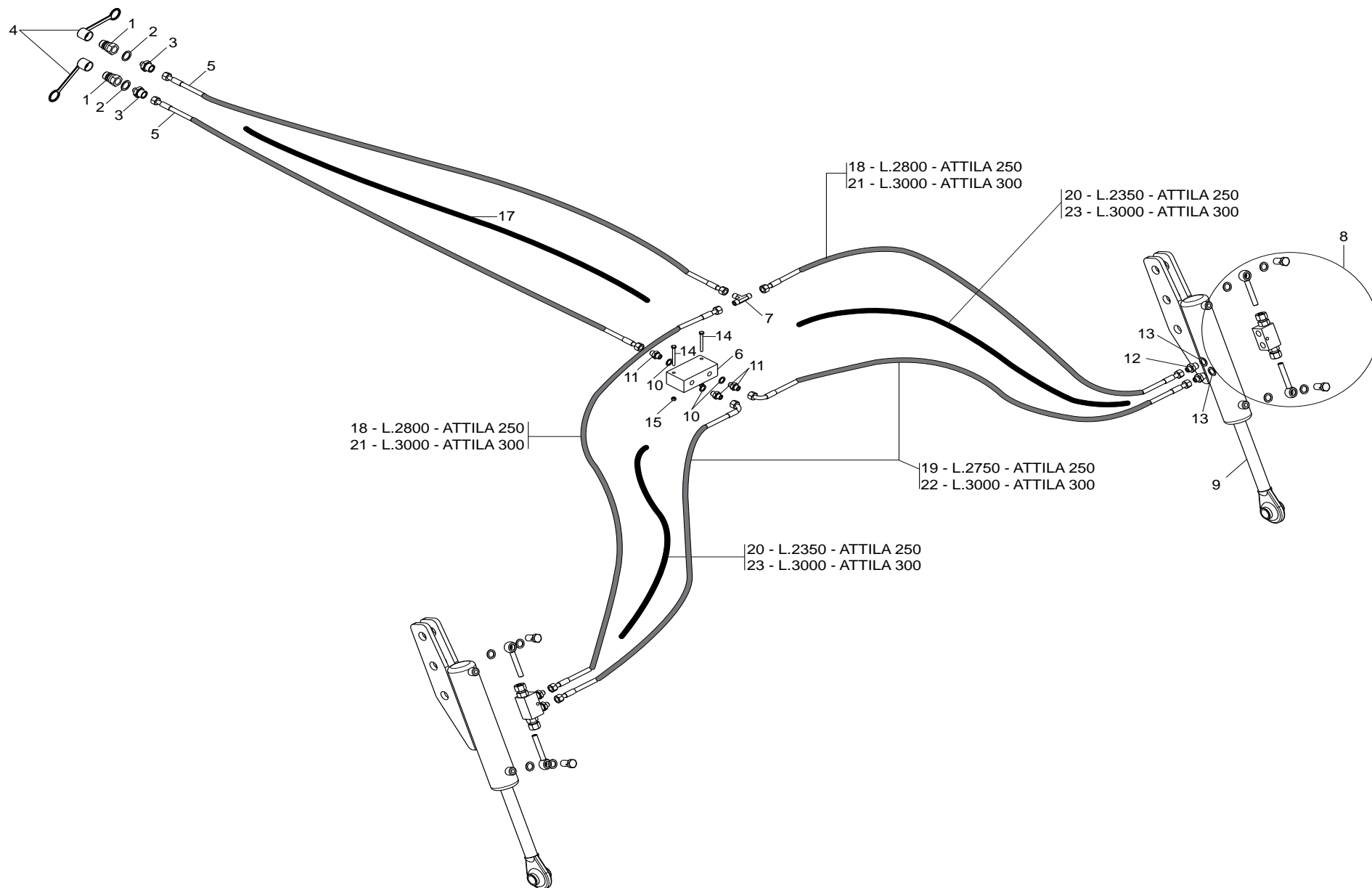

# IMPIANTO OLEODINAMICO RULLO

TAV. 050

Pos.	Cod.	Descrizione	Description	Description	Benennung	Descripcion	Descriere
1	F03150935	INNESTO RAP.MASCH.1/2A VALV.	QUICK CONNECT MALE CONE 1/2 CO	CONNEXION RAPIDE MALE CONE 1/2	SCHNELLKUPPLUNG GEWINDE KONISC	ACOPLAMIENTO RAPIDO MACHO CONO	CONECTARE RAPIDA TATA.CU 1/2
2	F03151237	RONDELLA RAME 21X27X1,5 -1/2"	1/2 COPPER WASHER	RONDELLE CUIVRE 1/2	UNTERLEGSCHEIBE KUPFER 1/2	ARANDELA COBRE 1/2	SAIBARAME 1/2
3	F03150211	NIPPLO MM CIL-CIL 1/2-1/4 ZN	NIPPLE 1/4-1/2	NIPPLE 1/4-1/2	NIPPLE 1/4-1/2	NIPPLE 1/4-1/2	NIPLU 1/4-1/2
4	F05150325	CAPPUCCIO PROT.INNESTO RAP.1/2	COVER 1/2	COUVERCLE 1/2	DECKEL 1/2	TAPA 1/2	GLUGA CONECTARE 1/2
5	R17817920	TUBO 1/4 FF L=2000	PIPE 1/4 FF L=2000	TUBE 1/4 FF L=2000	ROHR 1/4 FF L=2000	TUBO 1/4 FF L=2000	TUB 1/4 FF L=2000
6	F03151044	DIVISORE DI FLUSSO A 2 VIE	FLOW DIVISOR	DIVISEUR DE FLUX	OELVERTEILER	DIVISOR DE FLUJO	DIVIZOR FLUX
7	F03151219	RACCORDO -T- MASCHIO 1/4 ZN	MALE T-UNION 1/4 ZINC.	RACCORD -T- MALE 1/4 ZING.	ANSCHLUSSTsCK-T- GEWINDE 1/4	UNIN -T- MACHO 1/4 CINC. R	ACORD -T- TATA 1/4 ZINC. R
8	F03151158	KIT VALVOLABLOCCO 3/8 7014200	KIT CHECK VALVES 3/8 7014200	KIT CLAPET DE BLOCAGE 3/8	KIT RUCKSCHLAGVENTIL 3/8	KIT VALVULA ANTIRATORNO 3/8	KIT VALVABLOC 3/8 7014200
9	R17811481	CILINDRO 30X70 -280	CYLINDER 30X70 -280	CYLINDRE 30X70 -280	ZYLINDER 30X70 -280	CILINDRO 30X70 -280	ANSAMBLU CILINDRU 30X70 -280
10	F03151238	RONDELLA RAME 13X19X1,5 -1/4"	1/4 COPPER WASHER	RONDELLE CUIVRE 1/4	UNTERLEGSCHEIBE KUPFER 1/4	ARANDELA COBRE 1/4	SAIBARAME 1/4
11	F03150266	NIPPLO MM CIL-CIL 1/4-1/4 ZN	NIPPLE GALV.CYL.MALE 1/4 ZN	NIPPLE MALE CYL. 1/4 ZN	NIPPELZYL.1/4 ZN	NIPPLE MACHO CIL.1/4 ZN	NIPLU TATA CIL.1/4 ZN
12	F03150310	NIPPLO MM CIL-CIL 3/8-1/4 ZN	NIPPLE GALV.CYL.MALE 3/8-1/4 ZN	NIPPLE MALE CYL.3/8-1/4 ZN	NIPPELZYL.3/8-1/4 ZN	NIPPLE MACHO CIL.3/8-1/4 ZN	NIPLU TATA CIL.3/8-1/4 ZN
13	F03151240	RONDELLA RAME 3/8	3/8 COPPER WASHER	RONDELLE CUIVRE 3/8	UNTERLEGSCHEIBE KUPFER 3/8	ARANDELA COBRE 3/8	SAIBARAME 3/8
14	F01020416	VITE M6X 1X55 U5739 8.8 ZN	BOLT M6X 1X55 U5739 8.8 ZN	VIS M6X 1X55 U5739 8.8 ZN	SCHR.M6X 1X55 U5739 8.8 ZN	TORN.M6X 1X55 U5739 8.8 ZN	SUR. M6X 1X55 U5739 8.8 ZN
15	F01220011	DADO M6X 1 D980 8 ZG	SELF LOCKING NUT M6	ECROU AUTOBL. M6	SELBSTSPERR.MUTTER M6	DADO AUTOBL. M6	PIULITAAUTOFRINARE M6 USM8-98
16	F05150058	FASCETTA POLYAM.7,8X550 31920	POLYAMIDE FASTENING STRAPS 9X5	COLLIER POLYAMIDE 9X508 31920	SCHELLE POLYAMID 9X508 31920	ABRAZADERA POLIAMIDA 9X508 31920	COLIER PLASTIC 9X508 31920
17	F03100383	GUAINA TELATAD=65 L=1750	SHEATH D=65 L=1750	GAINIE D=65 L=1750	KABEL D=65 L=1750	VAINA D=65 L=1750	PROTECTIE TEXTILA D=65 L=1750
18	G17915100	TUBO 1/4 F-F L.2800	PIPE 1/4 F-F L.2800	TUBE 1/4 F-F L.2800	ROHR 1/4 F-F L.2800	TUBO 1/4 F-F L.2800	TUB 1/4 F-F L.2800
19	G15210551	TUBO 1/4R2 C-F L.2750 LM	PIPE 1/4R1 C-F L.2750 LM	TUBE 1/4R1 C-F L. 2750 LM	ROHR 1/4R1 C-F L.2750 LM	TUBO 1/4R1 C-F L.2750 LM	TUB 1/4R2 C-F L.2750 LM
20	F03100362	GUAINA TELATAD=65 L=2350	SHEATH D=65 L=2350	GAINIE D=65 L=2350	KABEL D=65 L=2350	VAINA D=65 L=2350	PROTECTIE TEXTILA D=65 L=2350
21	R17814480	TUBO 1/4R2 F1/4-F1/4 L=3000	PIPE 1/4R2 F1/4-F1/4 L=3000	TUBE 1/4R2 F1/4-F1/4 L=3000	ROHR 1/4R2 F1/4-F1/4 L=3000	TUBO 1/4R2 F1/4-F1/4 L=3000	TUB 1/4R2 F1/4-F1/4 L=3000
22	G15210631	TUBO 1/4R2 CF1/4- F1/4 3000	TUBE 1/4R2 CF1/4- F1/4 3000	TUBE 1/4R2 CF1/4- F1/4 3000	ROHR 1/4R2 CF1/4- F1/4 3000	TUBO 1/4R2 CF1/4- F1/4 3000	TUB 1/4R2 CF1/4- F1/4 3000
23	F03100371	GUAINA TELATAD=65 L=3000	SHEATH D=65 L=3000	GAINIE D=65 L=3000	KABEL D=65 L=3000	VAINA D=65 L=3000	PROTECTIE D=65 L=3000

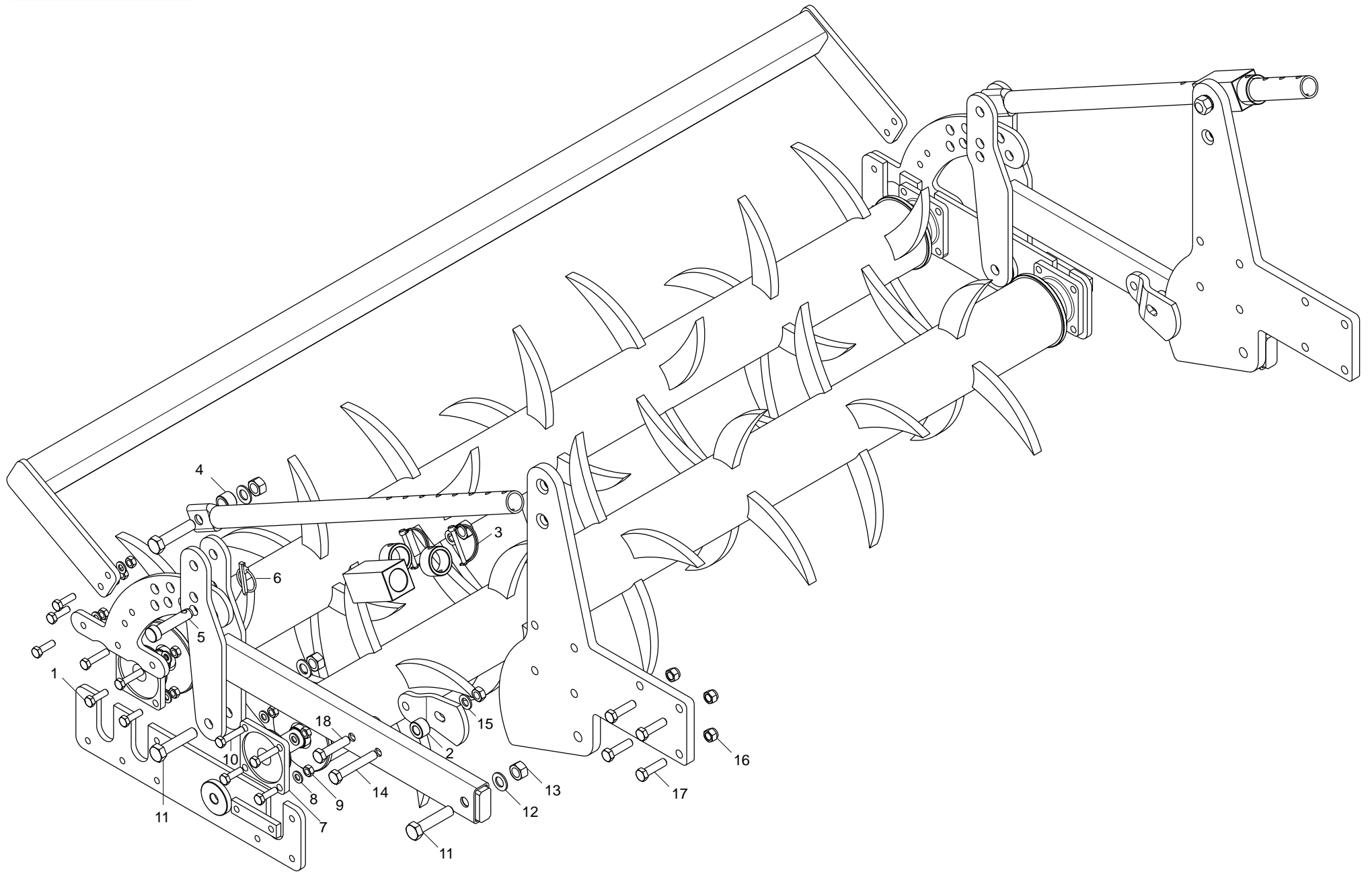

# DOPPIO RULLO POSTERIORE MECCANICO

TAV. 060

Pos.	Cod.	Descrizione	Description	Description	Benennung	Descripcion	Descriere
1	F01020152	VITE M12X1,75X40 U5737 8.8 ZB	BOLT M12X1,75X40 5737 8.8 ZB	VIS M12X1,75X40 5737 8.8 ZB	SCHR.M12X1,75X40 5737 8.8 ZB	TORN.M12X1,75X40 5737 8.8 ZB	SUR. M12X1,75X40 5737 8.8 ZB
2	R17813230	BOCCOLA	BUSCHING	BOITE	BsCHSE	CASQUILLO	BUCSADISTANTATOARE
3	F02200562	SPINA SICUR. D. 8X70 ZN	SPLIT PIN D.8X70 ZB	GOUPILLE D.8X70 ZB	BOLZEN D.8X70 ZB	PERNO D.8X70 ZB	STIFT DE SIGURANTAD.8X70 ZB
4	R17812000	BOCCOLA 21,7X33,7X23 ZN	BUSHING 21,7X33,7X23 ZN	BOITE 21,7X33,7X23 ZN	BsCHSE 21,7X33,7X23 ZN	CASQUILLO 21,7X33,7X23 ZN	BUCSA 21,7X33,7X23 ZN
5	R17813310	PERNO	SCREW	VIS	SCHRAUBE	TORNILLO	BOLT DE POZITIE ZB
6	F02200507	SPINA SCATTO D. 9 B/83 ZN	SNAP PIN D 9 B/83	FICHE A DETENTE D 9 B/83	EINRASTSTIFT D 9 B/83	CLAVIJADE MUELLE D 9 B/83	STIFT RESORT D 9 ZB B/83
7	F04100073	SUPPORTO CUSCINETTO FY35TF	BEARING SUPPORT	SUPPORT ROULEMENT	LAGERHALTERUNG	SOPORTE COJINETE	SUPORT RULMENT FY35TF
8	F01410076	RONDELLA D12 UNI 6592 ZN	PLANE WASHER D12 UNI 6592 ZN	RONDELLE D12 UNI 6592 ZN	SCHEIBE D12 UNI 6592 ZN	ARANDELA D12 UNI 6592 ZN	SAIBA PLANA D12 UNI 6592 ZB
9	F01230059	DADO M12X1,75 D982 8 ZB	NUT M12X1,75 D982 8 ZB	ECRO.M12X1,75 D982 8 ZB	MUTT.M12X1,75 D982 8 ZB	TUER.M12X1,75 D982 8 ZB	PIUL.M12X1,75 D982 8 ZB
10	F01020160	VITE M12X1,75X60 U5737 8.8 ZG	BOLT M12X1,75X60 U5737 8.8 ZG	VIS M12X1,75X60 U5737 8.8 ZG	SCHRAUBE M12X1,75X60 U5737 8.8	TORNILLO M12X1,75X60 U5737 8.8	SURUB M12X1,75X60 5737 8.8 ZB
11	F01020325	VITE M20X2,5X90 U5737 10.9 ZD	BOLT 20X90 5737 10.9G GALVANI	VIS 20X90 5737 10.9G ZN	SCHRAUBE 20X90 5737 10.9G ZN	TORNILLO 20X90 5737 10.9G ZN	SURUB 20X90 5737 10.9 ZN
12	F01410124	ROS.M20 21X 37X 3 U6592 ZG	PLANE WASHER D20 UNI 6592 ZN	RONDELLE D20 UNI 6592 ZN	SCHEIBE D20 UNI 6592 ZN	ARANDELLA D20 UNI 6592 ZN	SAIBA PLANA D20 UNI 6592 ZB
13	F01230131	DADO M20X 2,5 D982 6 ZB	NUT M20X 2,5 D982 6 ZB	ECRO.M20X 2,5 D982 6 ZB	MUTT.M20X 2,5 D982 6 ZB	TUER.M20X 2,5 D982 6 ZB	PIUL.M20X 2,5 D982 6 ZB
14	F01020285	VITE M16X 2X100 U5737 8.8 ZN	BOLT 16X100 5737 8.8 GALVANIZ	VIS 16X100 5737 8.8 ZN	SCHRAUBE 16X100 5737 8.8 ZN	TORNILLO 16X100 5737 8.8 ZN	SURUB 16X100 5737 8.8 ZN
15	F01410100	ROS.M16 17X 30X 3 U6592 ZG	PLANE WASHER D16 UNI 6592 ZN	RONDELLE D16 UNI 6592 ZN	SCHEIBE D.16 UNI 6592 ZN	ARANDELA D16 UNI 6592 ZN	SAIBA M16 17X 30X 3 U6592 ZB
16	F01230085	DADO M16X 2 D982 8 ZB	NUT M16X 2 D982 8 ZB	ECROU M16X 2 D982 8 ZB	MUTT.M16X 2 D982 8 ZB	TUER.M16X 2 D982 8 ZB	PIUL.M16X 2 D982 8 ZB
17	F01020260	SURUB M16X2X70 5739 8.8 ZB	BOLT M16X2X70 U5737 8.8 ZG	VIS M16X2X70 U5737 8.8 ZG	SCHRAUBE M16X2X70 U5737 8.8 ZG	TORNILLO M16X2X70 U5737 8.8 ZG	SURUB M16X2X70 5739 8.8 ZB
18	F01020262	VITE M16X 2X80 U5737 8.8 ZG	BOLT M16X80	VIS M16X80	SCHRAUBE M16X80	TORNILLO M16X80	SURUB M16X 2X80 U5737 8.8 ZB

BANDINELLA MECCANICA

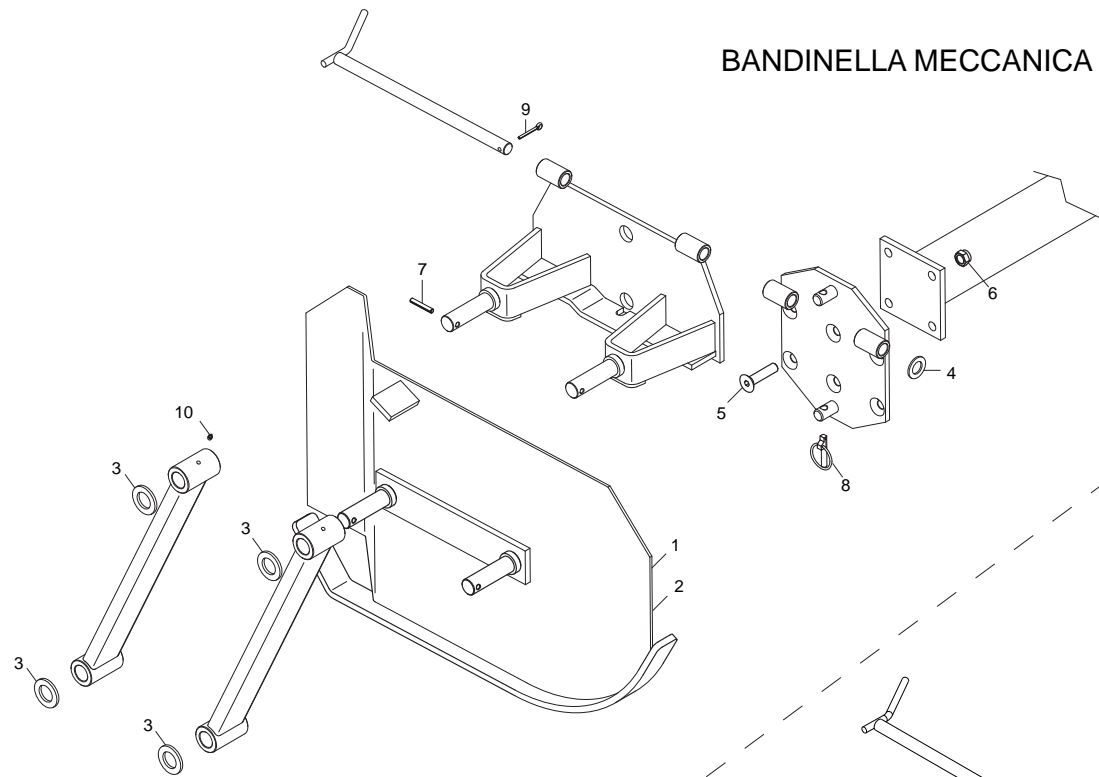

BANDINELLA IDRAULICA

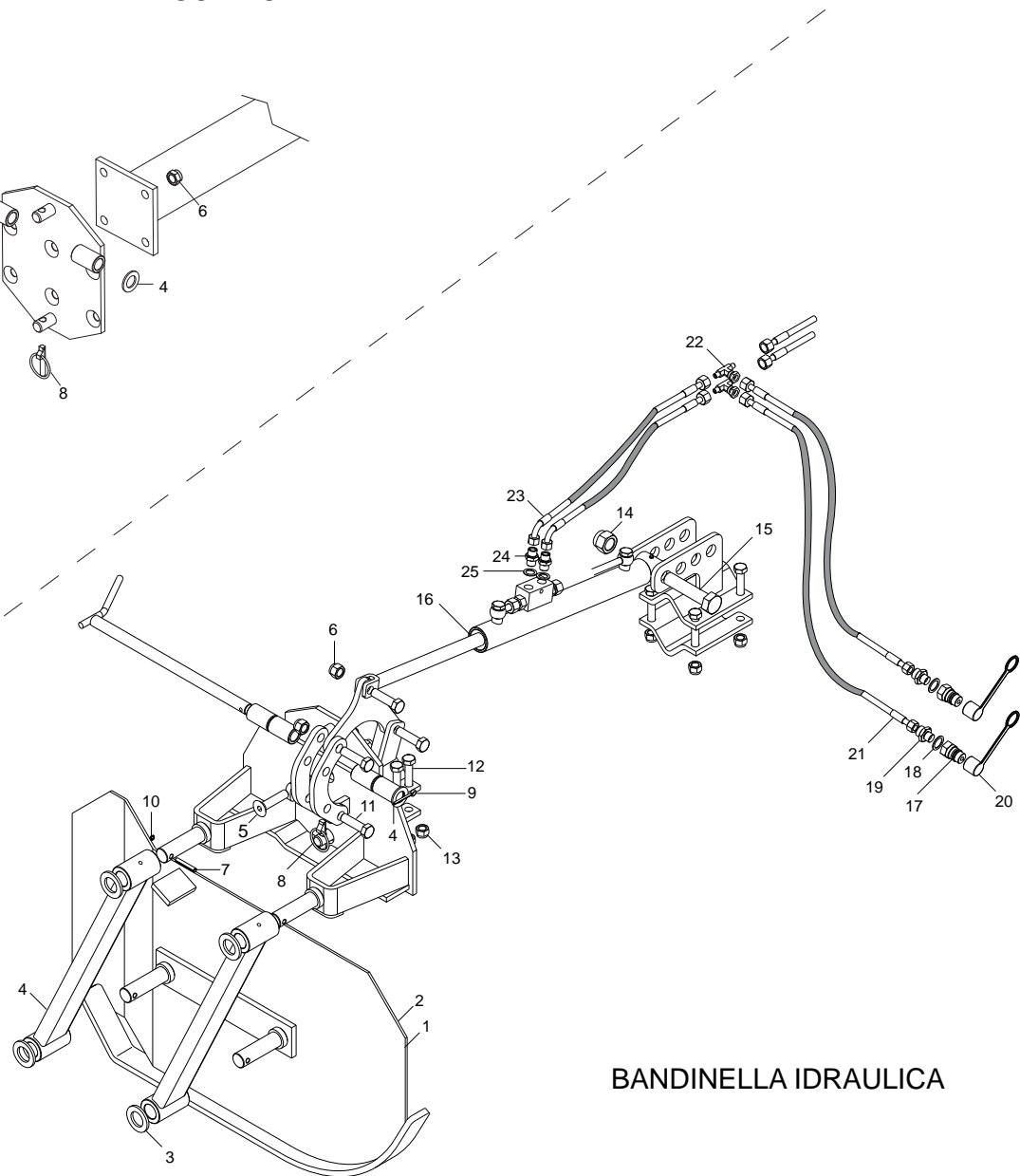



# BANDINELLE LATERALI

TAV. 070

Pos.	Cod.	Descrizione	Description	Description	Benennung	Descripcion	Descriere
1	R17811821	BANDELLA DX	PROTECTION DX	PROTECTION DX	SCHUTZ DX	PROTECCION DX	ANSAMBLU PROTECTIE DX
2	R17811831	BANDELLA SX	PROTECTION SX	PROTECTION SX	SCHUTZ SX	PROTECCION SX	ANSAMBLU PROTECTIE SX
3	G18700570	RONDELLA 20X54X6	WASHER 20X54X6	RONDELLE 20X54X6	SCHEIBE 20X54X6	ARANDELA 20X54X6	SAIBA 20X54X6
4	F01410135	ROS.M22 23X 39X 3 U6592 ZG	PLANE WASHER D.22	BAGUE D.22	SCHEIBE D.22	ARANDELA D.22	SAIBA PLANA D.22 UNI 6592 ZB
5	F01030152	VITE M16X 2X70 U5933 8.8 ZN	BOLT M16X2X70 U5933 8.8 ZB	VIS M16X2X70 U5933 8.8 ZB	SCHRAUBE M16X2X70 U5933 8.8 ZN	TORNILLO M16X2X70 U5933 8.8 ZB	SUR.M16X 2X 70 U5933 8.8 ZB
6	F01230085	DADO M16X 2 D982 8 ZB	NUT M16X 2 D982 8 ZB	ECROU M16X 2 D982 8 ZB	MUTT.M16X 2 D982 8 ZB	TUER.M16X 2 D982 8 ZB	PIUL.M16X 2 D982 8 ZB
7	F02100144	SPINA E.P. 8X50 U6873 C70 BR	ELASTIC PIN 8X50 1481	GOUJON ELASTIQUE 8X50 1481	SPANNHUELSE 8X50 1481	ESPINA ELASTICA 8X50 1481	STIFT ELASTIC 8X50 DIN 1481
8	F02200507	SPINA SCATTO D. 9 B/83 ZN	SNAP PIN D 9 B/83	FICHE A DETENTE D 9 B/83	EINRASTSTIFT D 9 B/83	CLAVIJA DE MUELLE D 9 B/83	STIFT RESORT D 9 ZB B/83
9	F02200229	COPIGLIA 5X45 U1336 ZN	SPLIT PIN 5 X45 1336 GALVAN.	GOUPILLE 5 X45 1336 ZN	SPLINT 5 X45 1336 ZN	PASADOR 5 X45 1336 ZN	SPLINT 5 X45 1336 ZB
10	F01100048	ING.M 8X1,25 7663A 9SMNPB28 ZG	SPHERE NIPPLE M8X 1,25 A	GRAISSEUR A BILLES M8 X 1-25 A	KUGELFETTBSCHSE M8 X 1-25 A	ENGRAS. DE ESFERAS M8 X 1-25 A	INGRANS. SFERIC M8 X 1,25 A ZB
11	F01020258	VITE M16X 2X 65 U5737 8.8 ZN	BOLT 16X65 5737 8.G GALVANIZED	VIS 16X65 5737 8.G ZN	SCHRAUBE 16X65 5737 8.G ZN	TORNILLO 16X65 5737 8.G ZN	SURUB M16X 2X 65 U5737 8.8 ZB
12	F01020205	VITE M14X2 X 65 5737 8.8 ZG	BOLT M 14X65	VIS M 14X65	SCHRAUBE M 14X65	TORNILLO M 14X65	VITE M14X2 X 65 5737 8.8 ZB
13	F01230073	PIULITAAUT.A M14X2 D982 8G Z	SELF LOCKING NUT M14X2	ECROU AUTOBL. M14X2	SELBSTSP.MUTT.M14X2	DADO AUTOBL. M14X2	PIULITA AUT.A M14X2 D982 8G Z
14	F01230144	DADO M24X 3 D982 8 ZN	SELF-LOCKING NUT NORM.24 ZB	ECROU AUTOB.NORM.24 ZB	SELBSTSPERR. MUTTER NORM.24 ZB	TUERCA AUTOB. NORM.24 ZB	PIUL.M24X 3 D982 8 ZN
15	F01020348	VIT.M24X 3X140 U5737 8.8 ZN	BOLT M24X 3X140 U5737 8.8 ZB	VIS M24X 3X140 U5737 8.8 ZB	SCHR.M24X 3X140 U5737 8.8 ZB	TORN.M24X 3X140 U5737 8.8 ZB	SUR.M24X 3X140 U5737 8.8 ZB
16	R17841540	CILINDRO BANDINELA HIDRO	CYLINDER	CYLINDRE	ZYLINDER	CILINDRO	CILINDRU BANDINELA HIDRAULICA
17	F03150935	INNESTO RAP.MASCH.1/2A VALV.	QUICK CONNECT MALE CONE 1/2 CO	CONNEXION RAPIDE MALE CONE 1/2	SCHNELLKUPPLUNG GEWINDE KONISC	ACOPLAMIENTO RAPIDO MACHO CONO	CONNECTARE RAPIDA TATA.CU 1/2
18	F03151237	RONDELLA RAME 21X27X1,5 -1/2"	1/2 COPPER WASHER	RONDELLE CUIVRE 1/2	UNTERLEGSCHIEBE KUPFER 1/2	ARANDELA COBRE 1/2	SAIBA RAME 1/2
19	F03150211	NIPPLO MM CIL-CIL 1/2-1/4 ZN	NIPLE 1/4-1/2	NIPLE 1/4-1/2	NIPLE 1/4-1/2	NIPLE 1/4-1/2	NIPLU 1/4-1/2
20	F05150325	CAPPUCCIO PROT.INNESTO RAP.1/2	COVER 1/2	COUVERCLE 1/2	DECKEL 1/2	TAPA 1/2	GLUGA CONECTARE 1/2
21	R17817920	TUBO 1/4 FF L=2000	PIPE 1/4 FF L=2000	TUBE 1/4 FF L=2000	ROHR 1/4 FF L=2000	TUBO 1/4 FF L=2000	TUB 1/4 FF L=2000
22	F03151219	RACCORDO -T- MASCHIO 1/4 ZN	MALE T-UNION 1/4 ZINC.	RACCORD -T- MALE 1/4 ZING.	ANSCHLUSSSTCK-T- GEWINDE 1/4	UNIN -T- MACHO 1/4 CINC. R	ACORD -T- TATA 1/4 ZINC. R
23	G15210551	TUBO 1/4R2 C-F L.2750 LM	PIPE 1/4R1 C-F L.2750 LM	TUBE 1/4R1 C-F L. 2750 LM	ROHR 1/4R1 C-F L.2750 LM	TUBO 1/4R1 C-F L.2750 LM	TUB 1/4R2 C-F L.2750 LM
24	F03150310	NIPPLO MM CIL-CIL 3/8-1/4 ZN	NIPPLE GALV.CYL.MALE 3/8-1/4 ZN	NIPPLE MALE CYL.3/8-1/4 ZN	NIPPELZYL.3/8-1/4 ZN	NIPLE MACHO CIL.3/8-1/4 ZN	NIPLU TATA CIL.3/8-1/4 ZN
25	F03151240	RONDELLA RAME 3/8	3/8 COPPER WASHER	RONDELLE CUIVRE 3/8	UNTERLEGSCHIEBE KUPFER 3/8	ARANDELA COBRE 3/8	SAIBA RAME 3/8
26	F03100383	GUAINA TELATA D=65 L=1750	SHEATH D=65 L=1750	GAINE D=65 L=1750	KABEL D=65 L=1750	VAINA D=65 L=1750	PROTECTIE TEXTILA D=65 L=1750

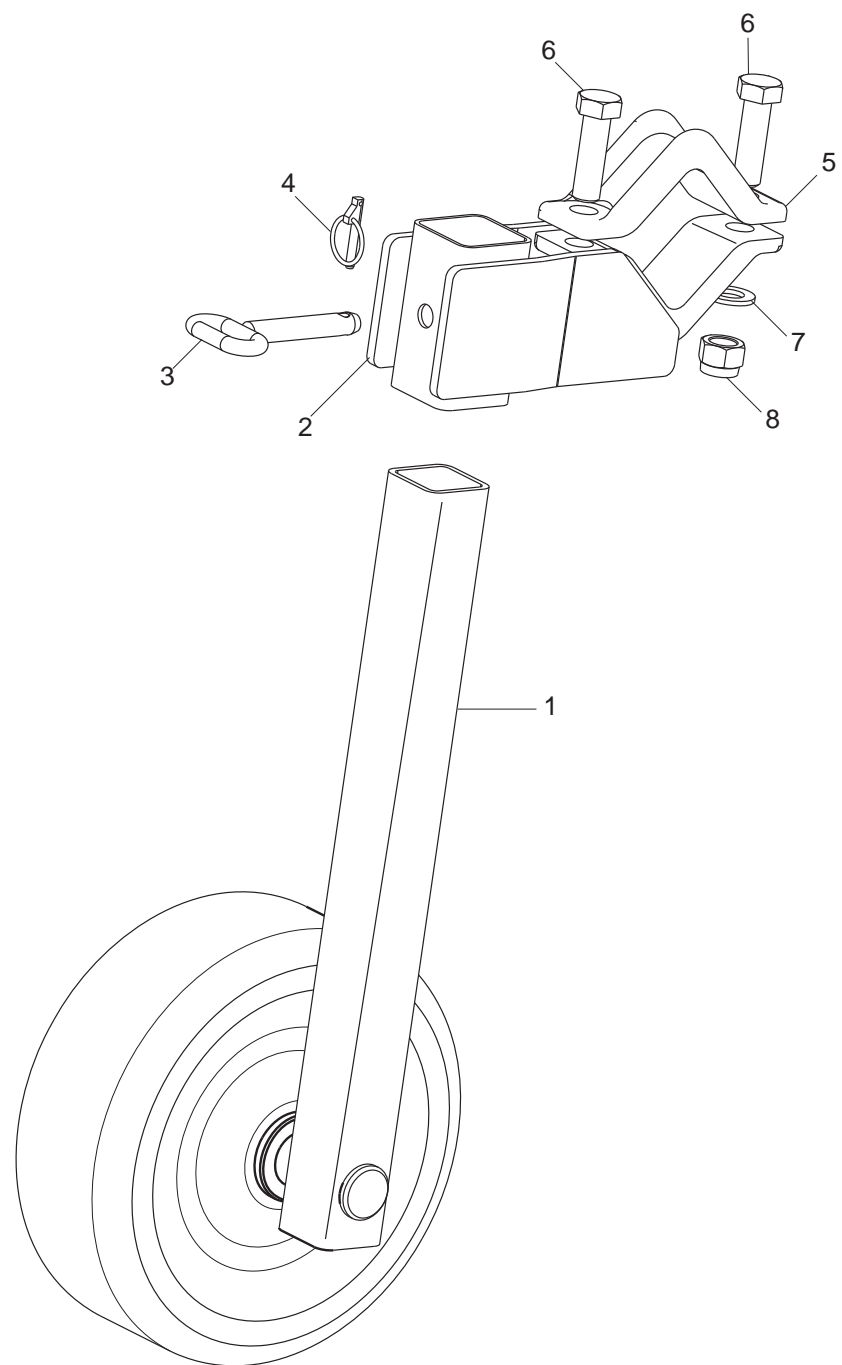

# RUOTE DI SOSTEGNO

TAV. 080

Pos.	Cod.	Descrizione	Description	Description	Benennung	Descripcion	Descriere
1	R18012160	ASSIEME RUOTA	ANS. WHEEL	ANS. ROUE	TIEFENRAD	SOPORTE RUEDA	ANSAMBLU ROATA
2	R17815720	SUPPORTO SOSTEGNO	SUPPORT SEALING	SUPPORT ETANCHEITE	HALTERUNG DICHTUNGS	SOPORTE AISLADOR	ANS.SUPPORT SUSTINERE
3	R17810440	PERNO ZN	PIN ZN	PIVOT ZN	BOLZEN ZN	PERNO ZN	BOLT ZN
4	F02200507	SPINA SCATTO D. 9 B/83 ZN	SNAP PIN D 9 B/83	FICHE A DETENTE D 9 B/83	EINRASTSTIFT D 9 B/83	CLAVIJA DE MUELLE D 9 B/83	STIFT RESORT D 9 ZB B/83
5	R17811170	SCONTRO PER TUBO 100	STRIKER PLATE 100	BUTEE 100	ANSCHLAG 100	ELEMENTO DE EMPALME 100	BRIDA FIXARE TEAVA 100
6	F01020343	VITE M24X 3X 80 U5737 10.9 ZD	BOLT M24X 3X 80 U5737 10.9 ZB	VIS M24X 3X 80 U5737 10.9 ZB	SCHR.M24X 3X 80 U5737 10.9 ZB	TORN.M24X 3X 80 U5737 10.9 ZB	SUR. M24X 3X 80 U5737 10.9 ZB
7	G18701590	RONDELLA 25X35X2,5 ZB	WASHER 25 x 35 x2,5 ZB	RONDELLE 25 x 35 x2,5 ZB	UNTERLEGSCHEIBE 25 x 35 x2,5	ARANDELA 25 x 35 x2,5 ZB	SAIBA 25X35X2,5 ZB
8	F01230144	DADO M24X 3 D982 8 ZN	SELF-LOCKING NUT NORM.24 ZB	ECROU AUTOB.NORM.24 ZB	SELBSTSPERR. MUTTER NORM.24 ZB	TUERCA AUTOB. NORM.24 ZB	PIUL.M24X 3 D982 8 ZN

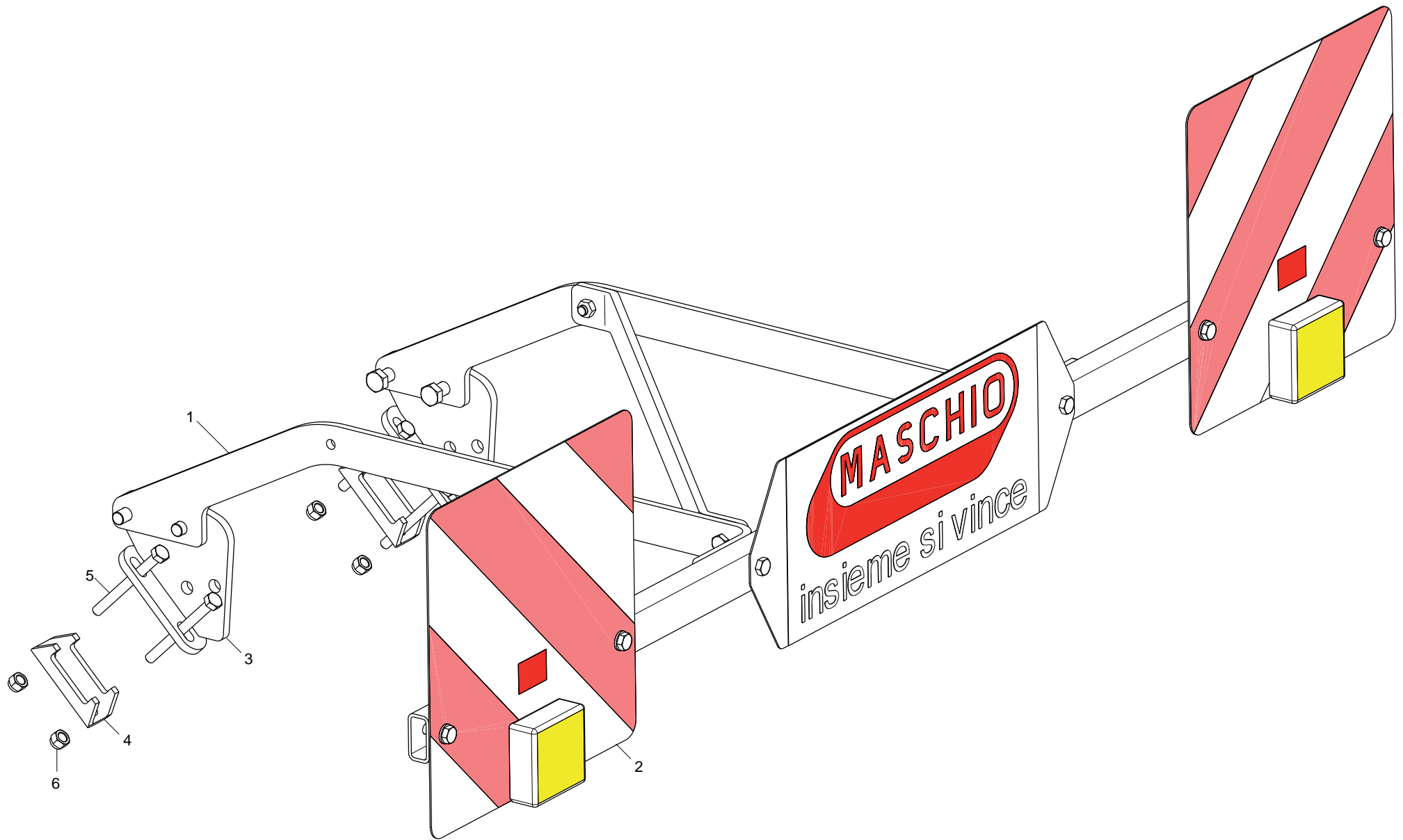

# KIT LUCI

TAV. 090

Pos.	Cod.	Descrizione	Description	Description	Benennung	Descripcion	Descriere
1	M12400957	FANALE KIT LUCI	LAMP KIT LIGHTS	FEU KIT ECLAIRAGE	LAMPENKIT LICHT	FAROL SET LUCES	FARURI PENTRU SET LUMINI
2	M12400956	KIT SUPPORTO BARRA LUCE	KIT SUPPORT	KIT SUPPORT	KIT HALTERUNG	KIT SOPORTE	KIT SUPORT BARA DE LUMINI
3	R17841000	ASSIEME ATTACCO	COUPLING	FIXATION	KUPPLUNG	CONEXIN	ANSAMBLU ATASARE
4	G16740160	SCONTRIO AU SP.8 2F13 83	U-SHAPED STOP TEETH B343SP.8	BUTEE EN U SP.8 2F13 83	U-ANSCHLAG SP.8 2F13 83	DIENTE DE PARADAA U ESP.8	BRIDA U SP.8 2F13 83
5	F01020174	VITE M12X1,75X120 5737 8.8 ZN	BOLT 12X120 5737 8.8 GALVANIZ.	VIS 12X120 5737 8.8 ZN	SCHRAUBE 12X120 5737 8.8 ZN	TORNILLO 12X120 5737 8.8 ZN	SUR. M12X1,75X120 5737 8.8 ZB
6	F01230059	DADO M12X1,75 D982 8 ZB	NUT M12X1,75 D982 8 ZB	ECRO. M12X1,75 D982 8 ZB	MUTT. M12X1,75 D982 8 ZB	TUER. M12X1,75 D982 8 ZB	PIUL. M12X1,75 D982 8 ZB

**USATE SEMPRE RICAMBI ORIGINALI  
ALWAYS USE ORIGINAL SPARE PARTS  
IMMER DIE ORIGINAL-ERSATZTEILE VERWENDEN  
EMPLOYEZ TOUJOURS LES PIECES DE RECHANGE ORIGINALES  
UTILIZAR SIEMPRE REPUESTOS ORIGINALES  
UTILIZAȚI ÎNTOTDEAUNA PIESE DE SCHIMB ORIGINALE**

**MASCHIO GASPARDO**

**Serviciu Asistentă Tehnică +40 752 30 70 43  
Piese de schimb +40 742 30 70 52**



**MASCHIO GASPARDO**

**R19530120**  
\*R19530120\*

**MASCHIO GASPARDO SpA**

**Sede legale e stabilimento produttivo**

Via Marcello, 73 - 35011 Campodarsego (Padova) - Italy  
Tel. +39 049 9289810  
Fax +39 049 9289900  
Email: info@maschio.com  
www.maschionet.com

**MASCHIO DEUTSCHLAND GMBH**

Äußere Nürnberger Straße 5  
D - 91177 Thalmässing ng  
Deutschland  
Tel. +49 (0) 9173 79000  
Fax +49 (0) 9173 790079

**MASCHIO FRANCE Sarl**

1, Rue de Mérignan ZA  
F - 45240 La Ferte St. Aubin  
France  
Tel. +33 (0) 2.38.64.12.12  
Fax +33 (0) 2.38.64.66.79

**MASCHIO IBERICA S.L.**

Calle Cabernet, 10  
Poligono Industrial Clot de Moja  
Olerdola - 08734 Barcelona  
Tel. +34 93.81.99.058  
Fax +34 93.81.99.059

**MASCHIO-GASPARDO USA Inc**

120 North Scott Park Road  
Eldridge, IA 52748 - USA  
Ph. +1 563 2859937  
Fax +1 563 2859938  
e-mail: info@maschio.us

**MASCHIO GASPARDO SpA**

**Stabilimento produttivo**

Via Mussons, 7 - 33075  
Morsano al Tagliamento (PN) - Italy  
Tel. +39 0434 695410  
Fax +39 0434 695425  
Email: info@gaspardo.it

**ООО МАСКИО-ГАСПАРДО РУССИЯ**

404126, Россия, Волгоградская область,  
г. Волжский, ул. Пушкина, 117 \*б\*.  
Тел.: +78443525065  
факс: +78443525064  
e-mail: info@maschio.ru  
http://www.maschionet.com

**MASCHIO GASPARDO ROMANIA SRL**

Strada Înfrățirii, Nr. 155  
315100 Chișineu - Criș  
Tel. +40 257 30 70 30  
Fax +40 257 30 70 40  
e-mail: info@maschio.com  
http://www.maschio.com

**MASCHIO MIDDLE EAST**

P.O. Box 922388  
Amman, 11192 Jordan  
Tel. 962 605511384  
Fax 962 6 5538398  
e-mail: tahaeng@nets.com.jo

**GASPARDO-MASCHIO TURCHIA**

**MASCHIO-GASPARDO CANADA Inc**  
**MASCHIO-GASPARDO CINA**  
**MASCHIO-GASPARDO POLAND**  
**MASCHIO-GASPARDO UCRAINA**  
**GASPARDO BIELORUSSIA**  
**MASCHIO-GASPARDO KOREA**