

MASCHIO GASPARDO

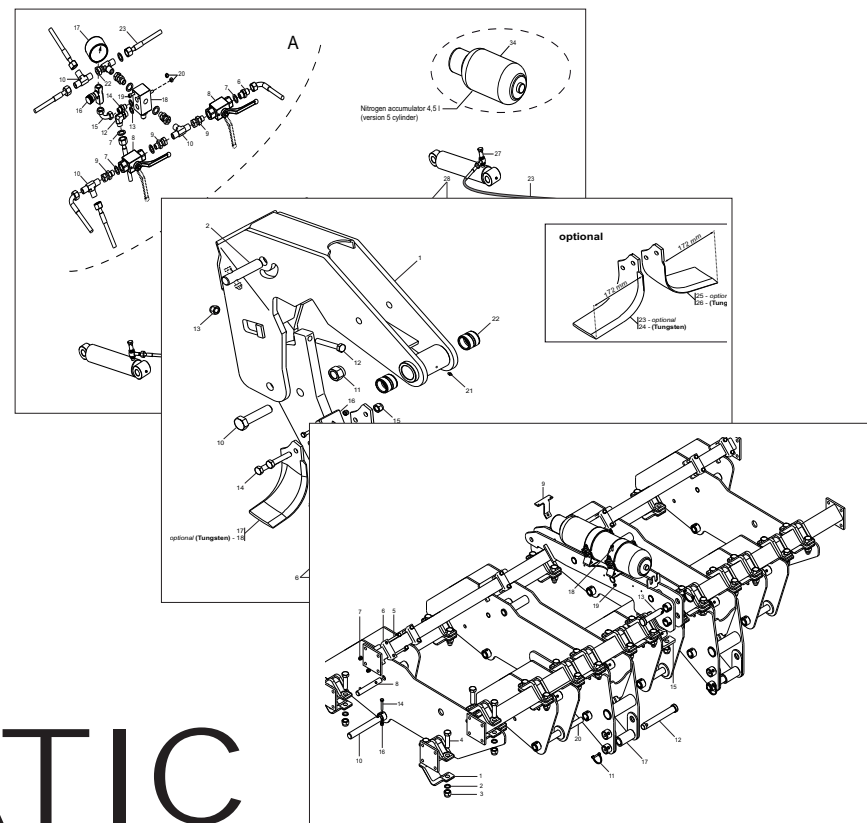

ATTILA HYDROPNEUMATIC

Cod: R19530121 11 / 2009

- *) Valido per Paesi UE
- *) Valid for EU member countries
- *) Gilt für EU-Mitgliedsländer
- *) Valable dans le Pays UE
- *) Válido para Países UE
- *) Valabil pentru țările UE

IT	PARTI DI RICAMBIO
EN	SPARE PARTS
DE	ERSATZTEILE
FR	PIECES DÉTACHÉES
ES	PIEZAS DE REPUESTO
RO	PIESE DE SCHIMB

PARTI DI RICAMBIO

Le ordinazioni delle parti di ricambio vanno fatte presso i nostri concessionari di zona e devono essere sempre corredate dalle seguenti indicazioni:

- **Tipo, modello e numero di matricola dell'attrezzatura.** Tali dati sono stampigliati nell'apposita targhetta di cui è dotata ogni attrezzatura.
- **Numero di codice della parte richiesta** rilevabile dal catalogo ricambi.
- **Descrizione del particolare e quantità richiesta.**
- **Numero della tavola.**
- **Mezzo di trasporto.** Nel caso questa voce non sia specificata, la Ditta Costruttrice, pur dedicando a questo servizio una particolare cura, non risponde di eventuali ritardi di spedizione dovuti a cause di forza maggiore.

Le spese di trasporto si intendono sempre a carico del destinatario. La merce viaggia a rischio e pericolo del committente anche se venduta franco destino.

NOTA: Il termine **(Dx) Destro** o **(Sx) Sinistro** della macchina o di parti di essa, è inteso guardando la macchina dalla parte posteriore. Le eccezioni saranno indicate.

SPARE PARTS

Orders must be transmitted through our area dealers and should always include the following indications:

- **Type, model and serial number of the machine.** These data are punched on the data plate with which every implement is equipped.
- **Code number of the required spare part.** This will be found in the spare parts catalogue.
- **Description of the part and required quantity.**
- **Table number.**
- **Means of dispatch.** If this item is not indicated, the Manufacturer, while dedicating particular care to this service, shall not be held responsible for delays in delivery caused by cases of force majeure.

Transport expenses shall always be at the consignee's charge. The goods travel at the purchaser's risk and peril even when sold ex destination.

NOTE: The symbols **(Dx) right** and **(Sx) left**, concerning the machine or single parts of it, are referred, as in the figure, to a rear view of them. Exceptions will be indicated.

ERSATZTEILE

Die Bestellungen müssen bei unseren Gebietshändler angegeben werden. Bei der Bestellung sind stets die folgenden Angaben zu machen:

- **Typ, Modell und Serien-Nummer des Geräts.** Diese Daten stehen auf dem Typenschild, mit dem jedes Gerät versehen ist.
- **Artikel Nr. der erforderlichen Ersatzteile.** Diese stehen im Ersatzteil-Katalog.
- **Beschreibung des Ersatzteils und die erforderliche Stückzahl.**
- **Tafelnummer.**
- **Versandmittel.** Wenn dieser Punkt nicht spezifiziert wird, haftet die Herstellerfirma nicht für etwaigen Lieferverzögerung aufgrund höherer Gewalt, auch wenn er diesen Service besonders aufmerksam abwickelt.

Die Frachtkosten gehen dagegen immer zu Lasten des Empfängers. Die Ware reist auf Gefahr und Risiko des Auftraggebers, auch wenn frei Haus verkauft vereinbart worden ist.

N.B.: Die Merkzeichen **(Dx) rechts** und **(Sx) links** betreffen eine rückwärtige Aussicht der Maschine oder Teile von ihr (siehe Bild). Ausnahmen werden gezeitigt.

PIECES DÉTACHÉES

Les ordres doivent être effectués auprès de nos concessionnaires de zone en précisant les indications suivantes:

- **Type, modèle et numéro de série de la machine.** Ces données sont gravées sur la plaque d'identification de chaque outil.
- **Numéro de code de la pièce détachée** indiqué sur le catalogue des pièces détachées.
- **Description de la pièce et quantité requise.**
- **Numéro de plan.**
- **Moyen d'expédition.** Si cette rubrique n'est pas indiquée, le Constructeur, bien que soucieux de ce service, ne répond pas des retards d'expédition pour des causes de force majeure. Les frais de transport sont toujours à la charge du destinataire. La marchandise voyage aux risques et périls de l'acheteur même si vendue franco de port.

N.B.: Les références **(Dx) droit** et **(Sx) gauche** de la machine ou des parties de la même, est entendue, comme de la figure, en regardant la machine de derrière dans le sens de marche.

RESPUESTOS

Los pedidos han de efectuarse en nuestros concesionarios de zona y deben incluir siempre las siguientes indicaciones:

- **Tipo, modelo y número de matrícula del equipo.** Dichos datos están impresos en la relativa placa presente en el equipo.
- **Número de código de la parte requerida** presente en el catálogo respuestas.
- **Descripción de la pieza y cantidad requerida.**
- **Numero de ilustración.**
- **Medio de transporte.** En caso que este ítem no esté especificado, el Fabricante, aún prestando la debidas consideraciones para este aspecto, no responde por eventuales retardos de env'ío debidos a causas de fuerza mayor.

Los gastos de transporte se consideran siempre a cargo del destinatario. La mercadería viaja bajo riesgo y peligro del comprador, incluso cuando se vende franco destino.

N.B.: La referencia **(Dx) derecha** o **(Sx) izquierda** de la máquina o de sus componentes, se entien-de, como en la figura, mirando la máquina por la parte trasera. Se indicarán las excepciones.

PIESE DE SCHIMB

Comandarea pieselor de schimb se va face prin intermediul concesionarilor din zonă și trebuie să fie întotdeauna însoțite de următoarele date:

- **Tipul, modelul și numărul de matricolă al utilajului.** Aceste date se găsesc pe plăcuța de identificare a fiecărui utilaj.
- **Numărul de cod al piesei de schimb cerute**, care se găsește în manual.
- **Descrierea piesei de schimb și cantitatea cerută.**
- **Numărul desenului în care se găsește piesa.**
- **Mijloc de transport.** În cazul în care acesta nu este specificat, Firma Constructoare poate avea un regim special, nu răspunde de eventualele întârzieri de expediere datorate unor cauze de forță majoră.

Cheltuielile de transport sunt suportate de destinatar. Marfa este transportată pe riscul celui care efectuează comanda, chiar dacă marfa este vândută în condiții franco-destinate.

NOTA: Termenul **(Dx) Dreapta** sau **(Sx) Stânga** a utilajului sau a părților acestuia, este privind utilajul din partea posterioară. Excepțiile vor fi indicate.

Nr. Tav.	Descrizione	Pag.	Nr. Tav.	Description	Pag.
TAV. 010	Telaio	4	TAV. 010	Cadre	4
TAV. 020	Elemento operatore	6	TAV. 020	Element operateur	6
TAV. 030	Impianto idropneumatico	8	TAV. 030	Installation hydropneumatique	8
TAV. 040	Doppio rullo posteriore idraulico	10	TAV. 040	Double rouleau posterieur hydraulique	10
TAV. 050	Impianto oleodinamico rullo	12	TAV. 050	Installation hydraulique rouleau	12
TAV. 060	Doppio rullo posteriore meccanico per ATTILA 250-300	14	TAV. 060	Double rouleau posterieur mecanique pour ATTILA 250-300	14
TAV. 070	Bandinella laterale meccanica	16	TAV. 070	Mecanique bande	16
TAV. 080	Ruote di profondità	18	TAV. 080	Roue de profondeur	18
TAV. 090	Kit luci	20	TAV. 090	Kit d'eclairage	20

Nr. Tav.	Description	Pag.	Nr. Tav.	Descripcion	Pag.
TAV. 010	Frame	4	TAV. 010	Bastidor	4
TAV. 020	Element operator	6	TAV. 020	Elemento operadore	6
TAV. 030	Hydropneumatic plant	8	TAV. 030	Instalacion hidroneumatica	8
TAV. 040	Hydraulic double rear roller	10	TAV. 040	Doble rollo posterior hidraulico	10
TAV. 050	Hydraulic plant roller	12	TAV. 050	Instalacion hidraulica rollo	12
TAV. 060	Mechanical double rear roller for ATTILA 250-300	14	TAV. 060	Doble rollo posterior mecanico para ATTILA 250-300	14
TAV. 070	Mechanical strip clod	16	TAV. 070	Bandas mecanica	16
TAV. 080	Depth wheel	18	TAV. 080	Rueda de profundidad	18
TAV. 090	Lighting kit	20	TAV. 090	Kit de iluminacion	20

Nr. Tav.	Beschreibung	Pag.	Nr. Tav.	Descriere	Pag.
TAV. 010	Rahmen	4	TAV. 010	Cadru	4
TAV. 020	Elemente betreiber	6	TAV. 020	Element operator	6
TAV. 030	Hydropneumatische Anzug	8	TAV. 030	Instalație hidropneumatică	8
TAV. 040	Hydraulischen doppelte nachaufwalze	10	TAV. 040	Rulou dublu posterior hidraulic	10
TAV. 050	Hydraulischen Anzug Walze	12	TAV. 050	Instalație hidraulică rulou	12
TAV. 060	Mechanische Doppelte Nachaufwalze für ATTILA 250-300	14	TAV. 060	Rulou dublu posterior mecanic pentru ATTILA 250-300	14
TAV. 070	Mechanische streifen	16	TAV. 070	Limitator de brazdă mecanic	16
TAV. 080	Block Tiefe	18	TAV. 080	Roată de adâncime	18
TAV. 090	Lichter kit	20	TAV. 090	Kit lumini	20

TAV. 010

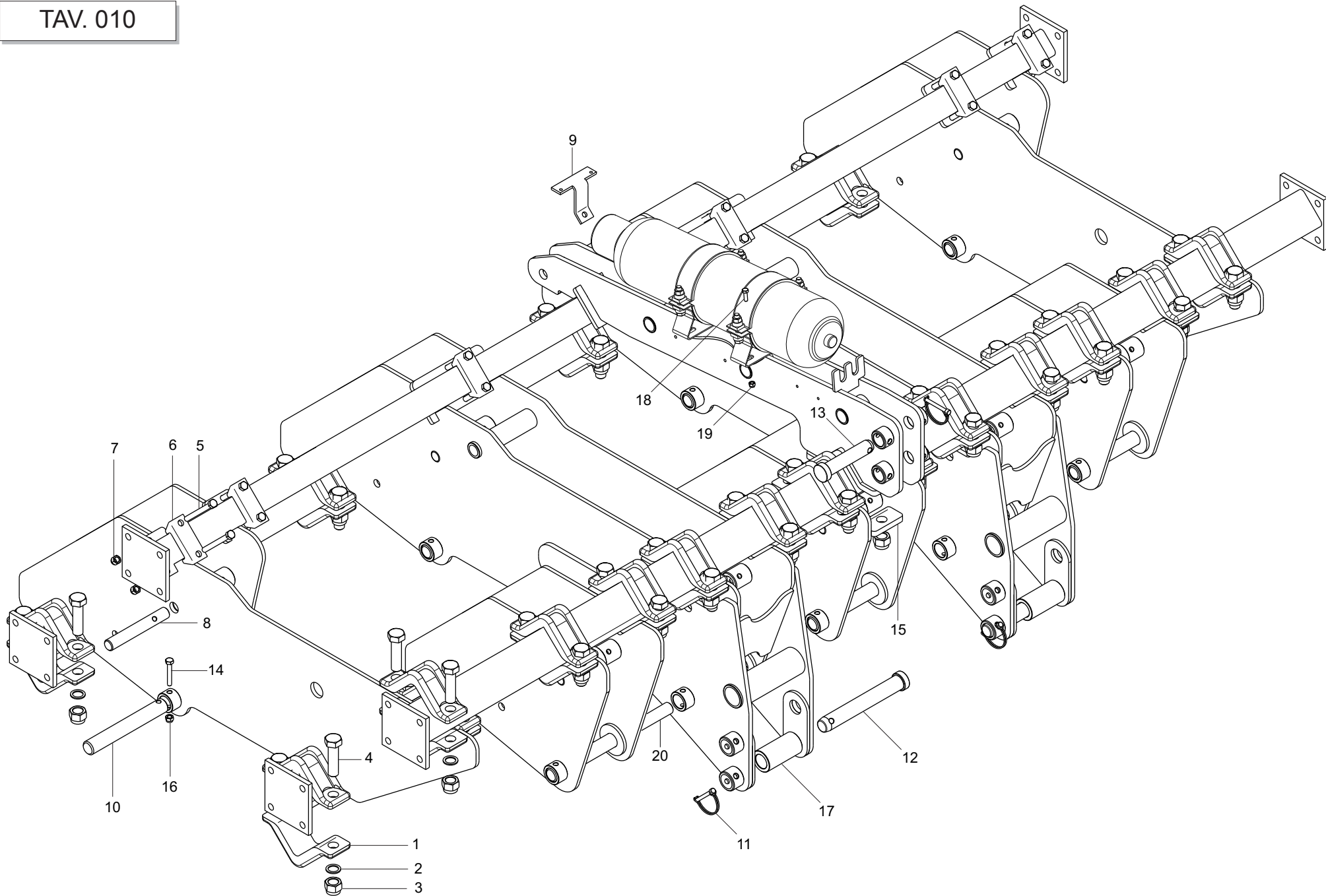

TELAIO / FRAME / RAHMEN / CADRE / BASTIDOR / CADRU

TAV. 010

Pos.	Cod.	Descrizione	Description	Description	Benennung	Descripcion	Descriere
1	R17811170	SCONTRO PER TUBO 100	FLANGE 100	ANSCHLAG 100	BUTEE 100	ELEMENTO DE EMPALME 100	BRIDA FIXARE TEAVA 100
2	G18701590	RONDELLA 25 X35 X2,5 ZN	WASHER 25 X35 X2,5 ZN	SCHEIBE 25 X35 X2,5 ZN	RONDELLE 25 X35 X2,5 ZN	ARANDELA 25 X35 X2,5 ZN	SAIBA 25X 35X 2,5 ZN
3	F01230144	DADO M24X 3 D982 8 ZN	NUT M24X 3 D982 8 ZN	MUTTER M24X 3 D982 8 ZN	ECROU M24X 3 D982 8 ZN	TUERCA M24X 3 D982 8 ZN	PIULITA M24X 3 D982 8 ZN
4	F01020343	VITE M24X 3X 80 U5737 10.9 ZN	SCREW M24X 3X 80 U5737 10.9 ZN	SCHR. M24X 3X 80 U5737 10.9 ZN	VIS M24X 3X 80 U5737 10.9 ZN	TORN. M24X 3X 80 U5737 10.9 ZN	SURUB M24X 3X 80 U5737 10.9 ZN
5	F01020174	VITE M12X1,75X120 U5737 8.8 ZN	SCREW M12X1,75X120 U5737 8.8ZN	SCHR.M12X1,75X120 U5737 8.8 ZN	VIS M12X1,75X120 U5737 8.8 ZN	TORN.M12X1,75X120 U5737 8.8 ZN	SUR. M12X1,75X120 U5737 8.8 ZN
6	G16740160	SCONTRO A U SP.8 2F13 83	FLANGE U SHIMS 8 2F13 83	U-ANSCHLAG DICKE 8 2F13 83	BUTEE EN U CALE 8 2F13 83	ELEM. DE EMPAL.U ESP.8 2F13 83	BRIDA U GR.8 2F13 83
7	F01230059	DADO M12X1,75 D982 8 ZN	NUT M12X1,75 D982 8 ZN	MUTTER M12X1,75 D982 8 ZN	ECROU M12X1,75 D982 8 ZN	TUERCA M12X1,75 D982 8 ZN	PIULITA M12X1,75 D982 8 ZN
8	R17814072	PERNO D28 L192 C43 ZN	BOLT D28 L192 C43 ZN	BOLZEN D28 L192 C43 ZN	BOULON D28 L192 C43 ZN	PERNO D28 L192 C43 ZN	BOLT D28 L192 C43 ZN
9	R17810950	LAMA SUPPORTO VALVOLA	SUPPORT BLADE VALVE	HALTERUNG MESSER VENTIL	SUPPORT LAME VALVE	CUCHILLA SOPORTE VALVULA	LAMA SUPORT VALVA
10	R17814082	PERNO D35 L236 HRC50	BOLT D35 L236 HRC50	BOLZEN D35 L236 HRC50	BOULON D35 L236 HRC50	PERNO D35 L236 HRC50	BOLT D35 L236 HRC50
11	F02200584	SPINA D12 L70 ZN	PIN D12 L70 ZN	STIFT D12 L70 ZN	FICHE D12 L70 ZN	CLAVIJA D12 L70 ZN	STIFT D12 L70 ZN
12	R17816581	PERNO D36 L235 ZN	BOLT D36 L235 ZN	BOLZEN D36 L235 ZN	BOULON D36 L235 ZN	PERNO D36 L235 ZN	BOLT D36 L235 ZN
13	F20100101	PERNO D32 L128 C43 ZN	BOLT D32 L128 C43 ZN	BOTZEN D32 L128 C43 ZN	BOULON D32 L128 C43 ZN	PERNO D32 L128 C43 ZN	BOLT D32 L128 C43 ZN
14	F01020120	VITE M10X 1,5X65 U5737 8.8 ZN	SCREW M10X1,5X65 U5737 8.8 ZN	SCHRA. M10X1,5X65 U5737 8.8 ZN	VIS M10X1,5X65 U5737 8.8 ZN	TORN. M10X1,5X65 U5737 8.8 ZN	SURUB M10X1,5X65 U5737 8.8 ZN
15	R17810041	SCONTRO PER ATTACCO TUBO 100	FLANGE FIXATION PIPE 100	ANSCHLAG KUPPLUNG ROHR 100	BUTEE FIXATION TUBE 100	EL.DE EMPALME FIJACION TUB.100	BRIDA FIXARE TUB 100
16	F01230048	DADO AUTOBLOC. M10 ZN	NUT AUTOBLOC. M10 ZN	SCHEIBE AUTOBLOC. M10 ZN	ECROU AUTOBLOC. M10 ZN	TUERCA AUTOBLOC M10 ZN	PIULITA AUTOBLOCANTA M10 ZN
17	R17818630	BOCCOLA D36.5 L110 ZN	BUSHING D36.5 L110 ZN	BUCHSE D36.5 L110 ZN	BUSHING D36.5 L110 ZN	CASQUILLO D36.5 L110 ZN	BUCSA D36.5 L110 ZN
18	F01020440	VITE M8X1,25X25 U5739 8.8 ZN	BOLT M8X1,25X25 U5739 8.8 ZN	SCHRA. M8X1,25X25 U5739 8.8 ZN	VIS M8X1,25X25 U5739 8.8 ZN	TORNIL.M8X1,25X25 U5739 8.8 ZN	SURUB M8X1,25X 25 U5739 8.8 ZN
19	F01230034	DADO AUTOBL.M8X1,25 D982 8 ZN	SELF LOCK.NUT M8X1,25 D982 8ZN	SELBST.MUTT.M8X1,25 D982 8 ZN	ECROU AUTOBL.M8X1,25 D982 8 ZN	TUERCA AUTO. M8X1,25 D982 8 ZN	PIULITA AUT. M8X1,25 D982 8 ZN
20	R17816572	PERNO D35 L274 39NI CR	BOLT D35 L274 39NI CR	BOLZEN D35 L274 39NI CR	BOULON D35 L274 39NI CR	PERNO D35 L274 39NI CR	BOLT D35 L274 39NI CR

TAV. 020

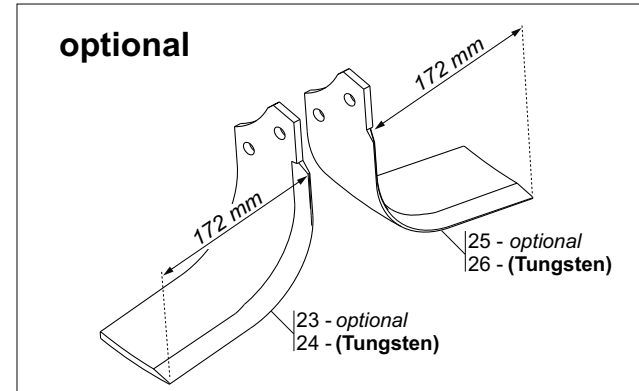
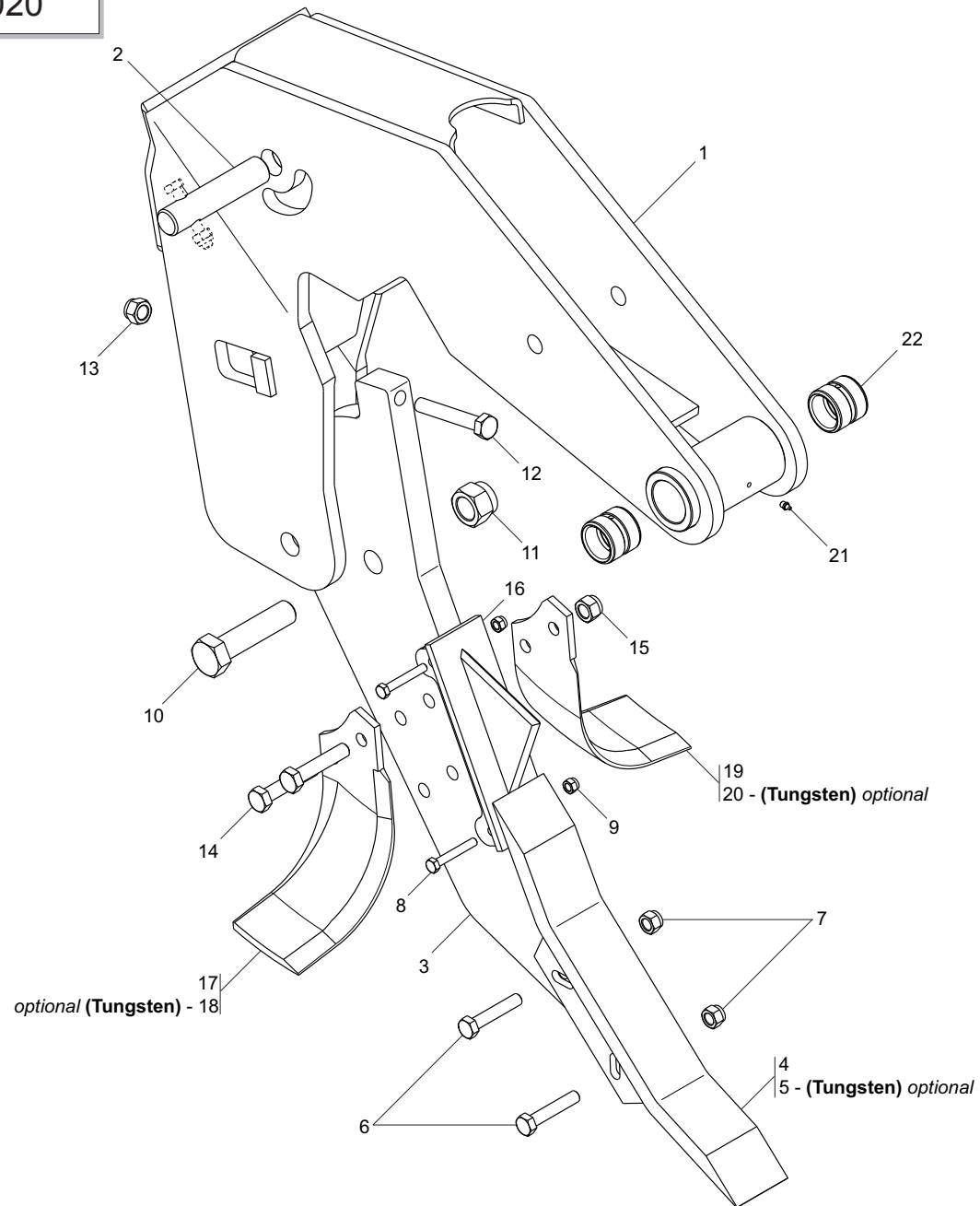

**ELEMENTO OPERATORE / ELEMENT OPERATOR / ELEMENTE BETREIBER / ELEMENT OPERATEUR /
ELEMENTO OPERADORE / ELEMENT OPERATOR**

TAV. 020

Pos.	Cod.	Descrizione	Description	Description	Benennung	Descripcion	Descriere
1	R17817151	SUPPORTO PUNTALE ATTILA	SUPPORT EARTH-OPENING BLADE	MESSERHALTER ATTILA	SUPPORT EMBOUT ATTILA	SOPORTE PUNTAL ATTILA	ANS.SUSTINERE VARF ATTILA
2	R17814061	SPINA D28 L100 C43 ZN	BOLT D28 L100 C43 ZN	BOLZEN D28 L100 C43 ZN	BOULON D28 L100 C43 ZN	PERNO D28 L100 C43 ZN	STIFT D28 L100 C43 ZN
3	R17820561	PUNTALE	TIP	STUTZE	EMBOUT	PUNTAL	VARF
4	R17820681	DENTE	TOOTH	ZAHN	DENT	DIENTE	DINTE
5	R17820731	DENTE TG	TOOTH TG	ZAHN TG	DENTE TG	DIENTE TG	DINTE TG
6	F01020164	VITE M12X1,75X70 U5737 8.8 ZN	SCREW M12X1,75X70 U5737 8.8 ZN	SCHR. M12X1,75X70 U5737 8.8 ZN	VIS M12X1,75X70 U5737 8.8 ZN	TORN. M12X1,75X70 U5737 8.8 ZN	SURUB M12X1,75X70 U5737 8.8 ZN
7	F01230059	DADO M12X1,75 D982 8 ZN	NUT M12X1,75 D982 8 ZN	MUTTER M12X1,75 D982 8 ZN	ECROU M12X1,75 D982 8 ZN	TUERCA M12X1,75 D982 8 ZN	PIULITA M12X1,75 D982 8 ZN
8	F01020075	VITE M8X1,25X 55 U5737 8.8 ZN	BOLT 8 X55 5737 8.8 GALVANIZED	SCHRAUBE 8 X55 5737 8.8 ZN	VIS 8 X55 5737 8.8 ZN	TORNILLO 8 X55 5737 8.8 ZN	SUR. M8X1,25X 55 U5737 8.8 ZB
9	F01230034	DADO AUTOBL.M8X1,25 D982 8 ZN	SELF LOCK.NUT M8X1,25 D982 8ZN	SELBST.MUTT.M8X1,25 D982 8 ZN	ECROU AUTOBL.M8X1,25 D982 8 ZN	TUERCA AUTO. M8X1,25 D982 8 ZN	PIULITA AUT. M8X1,25 D982 8 ZN
10	F01020344	VITE M24X3X100 U5737 10.9 ZN	SCREW M24X3X100 U5737 10.9 ZN	SCHRAU.M24X3X100 U5737 10.9 ZN	VIS M24X3X100 U5737 10.9 ZN	TORN. M24X3X100 U5737 10.9 ZN	SURUB M24X100 U5737 10.9 ZN
11	F01230144	DADO M24X 3 D982 8 ZN	NUT M24X 3 D982 8 ZN	MUTTER M24X 3 D982 8 ZN	ECROU M24X 3 D982 8 ZN	TUERCA M24X 3 D982 8 ZN	PIULITA M24X 3 D982 8 ZN
12	F01020212	VITE M14X 2X 90 U5737 8.8 ZN	SCREW M14X 2X 90 U5737 8.8 ZN	SCHARUBE M14X2X90 U5737 8.8 ZN	VIS M14X 2X 90 U5737 8.8 ZN	TORNILLO M14X2X90 U5737 8.8 ZN	SURUB M14X 2X 90 U5737 8.8 ZN
13	F01260046	DADO FLANG. M14 D6923 8.8 ZN	NUT M14 D6923 8.8 ZN	MUTTER M14 D6923 8.8 ZN	ECROU M14 D6923 8.8 ZN	TUERCA M14 D6923 8.8 ZN	PIULITA FLANG.M14 D6923 8.8 ZN
14	F01020207	VITE M14X 2X 70 U5737 8.8 ZN	SCREW M14X2X70 U5737 8.8 ZN	SCHRAUBE M14X2X70 U5737 8.8 ZN	VIS M14X2X70 U5737 8.8 ZN	TORNILLO M14X2X70 U5737 8.8 ZN	SURUB M14X 2X 70 U5737 8.8 ZN
15	F01230073	DADO AUTOB. M14X2 D982 8 ZN	SELF LOCK. NUT M14X2 D982 8 ZN	SELBSTSP.MUTT. M14X2 D982 8 ZN	ECROU AUTOBL. M14X2 D982 8 ZN	TUERCA AUTOBL. M14X2 D982 8 ZN	PIULITA AUT. M14X2 D982 8 ZN
16	R17820411	LAME ROMPIZOLLE	CLOD-BREAKING BLADE	MESSER SCHOLLENBRECHER	LAME BRISE-MOTTES	CUCHILLA DESTERRONADOR	LAMA SPARGATOR BRAZDA
17	M74100435	ZAPPA AD ELICA DX	RIGHT HELICOIDAL BLADE	RECHT BOGENMESSER	LAME HELICE DROIT	AZADA HELICE DERECHA	SAPA ELICOIDALA DX
18	R17820860	ZAPPA AD ELICA DX TG	RIGHT HELICOIDAL BLADE TG	RECHT BOGENMESSER TG	LAME HELICE DROIT TG	AZADA HELICE DERECHA TG	SAPA ELICOIDALA DX TG
19	M74100436	ZAPPA AD ELICA SX	LEFT HELICOIDAL BLADE	LINK BOGENMESSER	LAME HELICE GAUCHE	AZADA HELICE IZQUIERDA	SAPA ELICOIDALA SX
20	R17820870	ZAPPA AD ELICA SX TG	LEFT HELICOIDAL BLADE TG	LINK BOGENMESSER TG	LAME HELICE GAUCHE TG	AZADA HELICE IZQUIERDA TG	SAPA ELICOIDALA SX TG
21	F01100011	ING.M 6X1 7663-A 9SMNPB28 ZN	GREASE NIPPLE M6X1 7663-A ZN	SCHMIERBUECHE M6X1 7663-A ZN	GRAISS. A BILLE M6X1 7663A ZN	ENGRAS. DE ESFERAS M6X1 7663-A	ING.M 6X1 7663-A 9SMNPB28 ZN
22	G15322860	BOCCOLA BRACCIO L.40	BUSHING ARM L.40	BUCHSE ARM L.40	BUSHING BRAS L.40	CASQUILLO BRAZO L.40	BUCSA BRAT L.40
23	R17820830	ZAPPA AD ELICE DX P30	RIGHT HELICOIDAL BLADE P30	RECHT BOGENMESSER DX P30	LAME HELICE DROIT P30	AZADA HELICE DERECHA P30	SAPA ELICOIDALA DX P30
24	R17820880	ZAPPA AD ELICA DX P30 TG	RIGHT HELICOIDAL BLADE P30 TG	RECHT BOGENMESSER P30 TG	LAME HELICE DROIT P30 TG	AZADA HELICE DERECHA P30 TG	SAPA ELICOIDALA DX P30 TG
25	R17820820	ZAPPA AD ELICA SX P30	LEFT HELICOIDAL BLADE P30	LINK BOGENMESSER P30	LAME HELICE GAUCHE P30	AZADA HELICA IZQUIERDA P30	SAPA ELICOIDALA SX P30
26	R17820890	ZAPPA AD ELICA SX P30 TG	LEFT HELICOIDAL BLADE P30 TG	LINK BOGENMESSER P30 TG	LAME HELICE GAUCHE P30 TG	AZADA ELICE IZQUIERDA P30 TG	SAPA ELICOIDALA SX P30 TG

TAV. 030

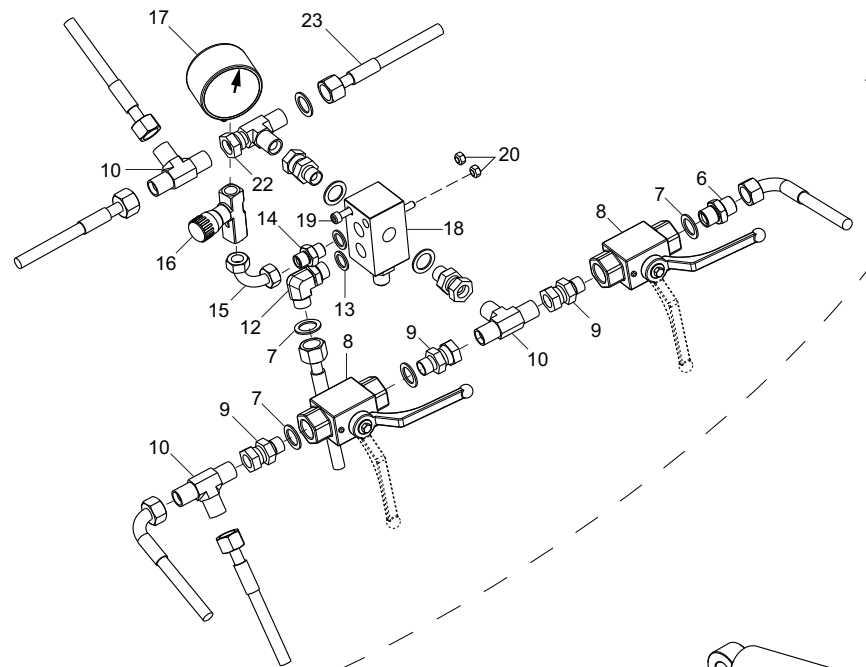

A

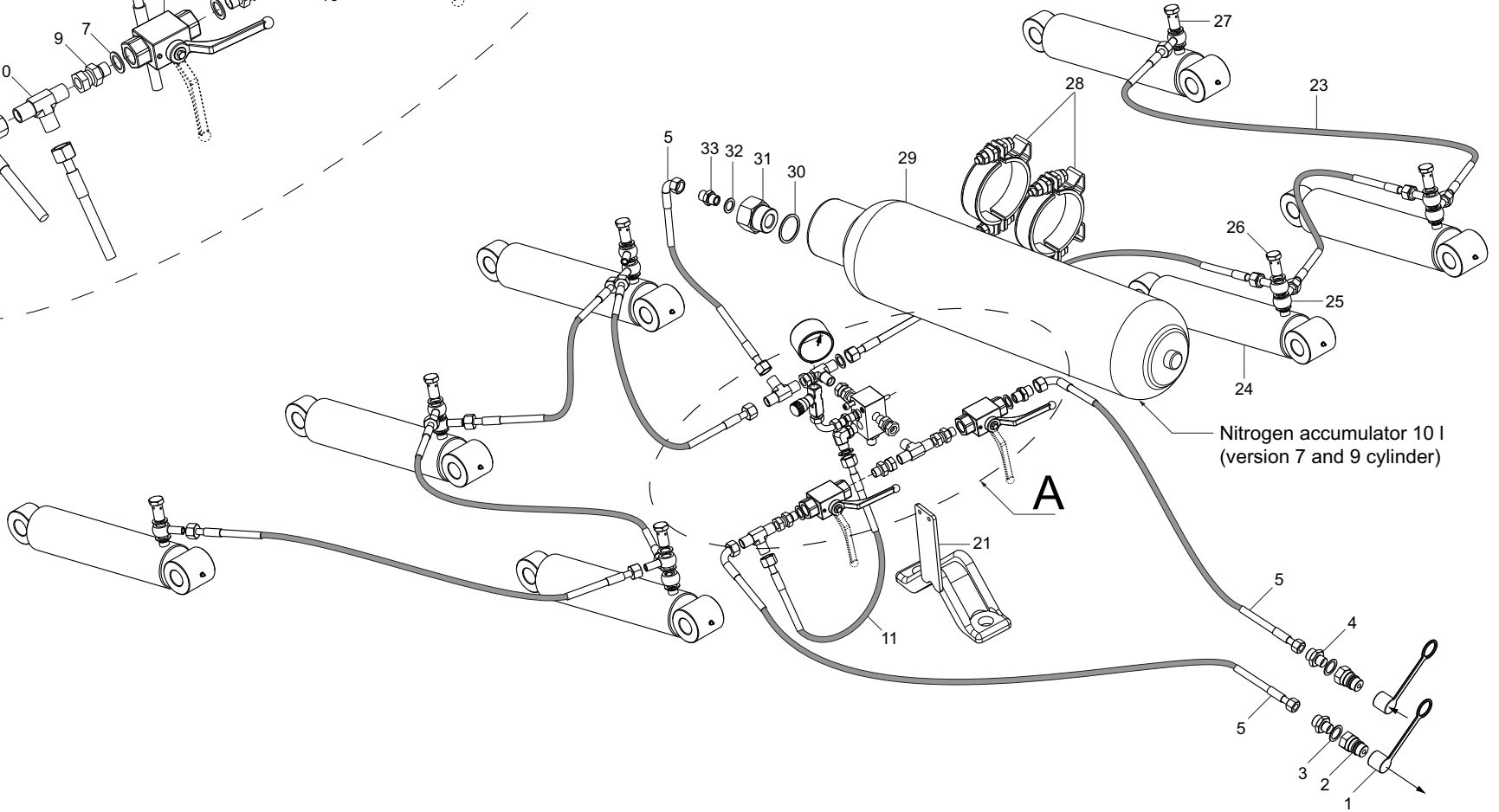
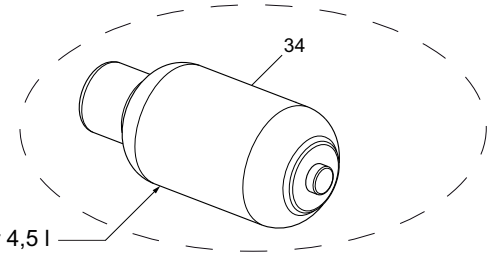

A

Nitrogen accumulator 10 l
(version 7 and 9 cylinder)

**IMPIANTO IDROPNEUMATICO / HYDROPNEUMATIC PLANT / HYDROPNEUMATISCHE ANZUG /
INSTALLATION HYDROPNEUMATIQUE / INSTALACION HIDRONEUMATICA / INSTALAȚIE HIDROPNEUMATICĂ**

TAV. 030

Pos.	Cod.	Descrizione	Description	Description	Benennung	Descripcion	Descriere
1	F05150325	CAPPUCCIO F. 1/2 ROSSO	COVER CONNECT F 1/2 RED	DECKEL W 1/2 SCHNELLKUPP. ROT	COUVERCLE CONNEXION F 1/2 ROSE	PAC PROTECCION F 1/2 ROJO	CAPAC PROTECTIE F 1/2 ROSU
2	F03150935	INNESTO RAP.MASCH.1/2 A VALV.	QUICK CONNECT MALE CONE 1/2	SCHNELLKUPP.GEWINDE KONISC 1/2	CONNEXION RAPIDE MALE CONE 1/2	ACOPLAMIENTO RAP.MACHO CONO 1/2	CONECTARE RAPIDA TATA 1/2 VAL.
3	F03151237	ROSSETA RAME 21 X27X1,5 1/2	COPPER WASHER 21X27X1,5 1/2	SCHEIBE KUPFER 21X27X1,5 1/2	RONDELLE CUIVRE 21X27X1,5 1/2	ARANDELA COBRE 21X27X1,5 1/2	SAIBA PLANA 21X27X1,5 1/2
4	F03150222	NIPPLLO M-M CIL-CIL 1/2-3/8 ZN	NIPPLE M-M CYL-CYL 1/2-3/8 ZN	NIPPEL M-M CIL-CIL 1/2-3/8 ZN	NIPPLE H-H CIL-CIL 1/2-3/8 ZN	NIPLLE H-H CIL-CIL 1/2-3/8 ZN	NIPLU T-T CIL-CIL 1/2-3/8 ZN
5	R17014030	TUBO 3/8R2 CF3/8- F3/8 1600	PIPE 3/8R2 CF3/8- F3/8 1600	ROHR 3/8R2 CF3/8- F3/8 1600	TUBE 3/8R2 CF3/8- F3/8 1600	TUBO 3/8R2 CF3/8- F3/8 1600	TUB 3/8R2 CF3/8- F3/8 1600
6	F03150321	NIPPLLO MM CIL-CIL 3/8-3/8 ZN	NIPPLE MM CYL-CYL 3/8-3/8 ZN	NIPPEL MM CIL-CIL 3/8-3/8 ZN	NIPPLE HH CIL-CIL 3/8-3/8 ZN	NIPLLE HH CIL-CIL 3/8-3/8 ZN	NIPLU TT CIL-CIL 3/8-3/8 ZN
7	F03151240	ROSSETA RAME 17X 23X1,5 3/8"	COPPER WASHER 17X23X1,5 3/8"	SCHEIBE KUPFER 17X23X1,5 3/8"	RONDELLE CUIVRE 17X23X1,5 3/8"	ARADNDELA COBRE 17X23X1,5 3/8"	SAIBA PLANA 17X23X1,5 3/8"
8	F03151246	RUBINETTO F-F 3/8	BREATHER TAP F-F 3/8	ENTLsFTUNGSPFROPFEN F-F 3/8	BOUCHON REFOUL. F-F 3/8	TAPON PURGADOR F-F 3/8	ROBINET F-F 3/8
9	F03150067	NIPPLLO MF GIROVOLE 3/8 ZG CIL	NIPPLE M-F SWIVEL 3/8 ZINC.	NIPPEL M-F DREHBAR 3/8 VERZINK	NIPPLE M-F TOURNANT 3/8 ZING.	NIPLLE M-H GIRATORIO 3/8 CINC.	NIPLU M-F ROTITOR 3/8 ZINC.
10	F03151220	RACCORDO -T- MASCHIO 3/8 ZN	MALE T-UNION 3/8 ZN.	ANSCHLUSS T-SCK-T-GEWINDE 3/8 ZN	RACCORD -T- MALE 3/8 ZN.	UNI N -T- MACHO 3/8 ZN.	RACORD -T- TATA 3/8 ZN.
11	R18512740	TUBO 3/8R2 F3/8- F3/8 500	PIPE 3/8R2 F3/8- F3/8 500	ROHR 3/8R2 F3/8- F3/8 500	TUBE 3/8R2 F3/8- F3/8 500	TUBO 3/8R2 F3/8- F3/8 500	TUB 3/8R2 F3/8- F3/8 500
12	F03150841	ADATTORE A 90° 3/8"	CONNECTOR 90° 3/8"	ANSCHLUSS 90° 3/8"	RACCORD 90° 3/8"	JUNTURA 90° 3/8"	ADAPTOR LA 90° 3/8"
13	F03151238	ROSSETA RAME 13X19X1,5 -1/4"	COPPER WASHER 13X19X1,5 -1/4"	SCHEIBE KUPFER 13X19X1,5 -1/4"	RONDELLE CUIVRE 13X19X1,5 -1/4"	ARANDELA COBRE 13X19X1,5 -1/4"	SAIBA PLANA 13X19X1,5 -1/4"
14	F03150266	NIPPLLO MM CIL-CIL 1/4-1/4 ZN	NIPPLE GALV.CYL.MALE 1/4 ZN	NIPPELZYL.1/4 ZN	NIPPLE MALE CYL. 1/4 ZN	NIPLLE MACHO CIL.1/4 ZN	NIPLU TATA CIL.1/4 ZN
15	F03150861	RACCORDO 90°F.G.1/4 - F.G.1/4	UNION 90°F.G.1/4 - F.G.1/4	ANSCHLUSS 90°F.G.1/4 - F.G.1/4	RACCORD 90°F.G.1/4 - F.G.1/4	UNION 90°F.G.1/4 - F.G.1/4	RACORD 90°F.G.1/4 - F.G.1/4
16	F03151267	RUBINETTO 1/4	COCK 1/4	HAHN 1/4	BOUCHON REFOUL 1/4	TAPON PURGADOR 1/4	ROBINET 1/4
17	F03151164	MANOMETRO B.G. DA 0 A 250 BAR	PRESSURE GAUGE B.G.0-250 BAR	MANOMETER B.G. DA 0 A 250 BAR	MANOMETRE B.G. 0-250 BAR	MANOMETRU B.G. 0-250 BAR	MANOMETRU B.G. 0-250 BAR
18	F03150593	VALVOLA VMP 3/8	VALVE VMP 3/8	VENTIL VMP 3/8	SOUPAPE VMP 3/8	VULA VMP 3/8	VALVA VMP 3/8
19	F01040069	VITE M 6X1X55 U5931 8.8 ZN	BOLT M 6X1X55	SCHRAUBE M 6X1X55	VIS M 6X1X55	TORNILLO M 6X1X55	SURUB M 6X1X55 U5739 8.8 ZB
20	F01220011	DADO M6X 1 D980 8 ZN	NUT M6X1 D980 8 ZN	MUTTER M6X1 D980 8 ZN	ECROU M6X1 D980 8 ZN	TUERCA M6X1 D980 8 ZN	PIULITA M6X1 D980 8 ZN
21	R17842260	ASSIEME FISSAGGIO VALVOLA	ASSEMBLY FIXATION VALVE	ZUSAMENBAU KUPPLUNG DRUCKVENT	ANSAMBLEE FIXATION SOUPAPE	ANSAMBLEA FIJACION VALVULA	ANSAMBLU FIXARE SUPAPA
22	F03151275	RACCORDO T M-M-FG 3/8' ZN	T-UNION M-M-FG 3/8' ZN	ANSCHLUSS T M-M-FG 3/8' ZN	RACCORD -T M-M-FG 3/8' ZN	UNION T M-M-FG 3/8' ZN	RACORD T M-M-FG 3/8' ZN
23	R17814610	TUBO 3/8 R2 F3/8-F3/8 L.1650	TUBE 3/8 R2 F3/8-F3/8 L.1650	ROHR 3/8 R2 F3/8 - F3/8 L.1650	TUBE 3/8 R2 F3/8-F3/8 L.1650	TUBO 3/8 R2 F3/8-F3/8 L.1650	TUB 3/8 R2 F3/8-F3/8 L.1650
24	R17814560	CILINDRO	CYLINDER	ZYLINDER	CYLINDRE	CILINDRU	CILINDRU
25	F03151269	OCCHIONE FILETATO 3/8-3/8	EYE FILET. 3/8-3/8	TSE FILET. 3/8 - 3/8	OEIL FILET. 3/8-3/8	ARGOLLA 3/8-3/8	OCHI FILETAT 3/8 -3/8
26	F03151224	VITE CAVA 3/8 8 FORI	SCREW 8 HOLE 3/8	SCHRAUBE 8 HOLE 3/8	VIS 8 CREUSE 3/8	TORNILLO RANURA 3/8 8 FORI	SURUB 3/8 8 GAURI
27	F03151223	VITE CAVA 3/8	SCREW 3/8	SCHRAUBE 3/8	VIS 3/8	TORNILLO CAVA 3/8	SURUB 3/8
28	F02350062	STAFFA FISS. ACCUMULATORE D170	BLADE FIXING ACCUMULATOR D170	MESSER HALTER.AKKUMULATOR D170	LAMA FIXAT. ACCUMULATEUR D170	CUCHILLA FIJAC.ACUMULADOR D170	PLACA FIXARE ACUMULATOR D170
29	F03151305	ACCUMULATORE 10L 210BAR	ACCUMULATOR 10L 210BAR	AKKUMULATOR 10L 210BAR	ACCUMULATEUR 10L 210BAR	ACUMULADOR 10L 210BAR	ACCUMULATOR 10L 210BAR
30	F03151306	ROSSETA 42 X50X1,5 RAME 1"1/4	WASHER 42 X50X1,5 RAME 1"1/4	SCHEIBE 42 X50X1,5 RAME 1"1/4	RONDELLE 42X50X1,5 RAME 1"1/4	ARANDELA 42X50X1,5 RAME 1"1/4	SAIBA 42 X50X1,5 RAME 1"1/4
31	F03151068	RIDUZIONE 1"1/4M - 3/4"F	REDUCTION 1"1/4M - 3/4"F	UNTERSETZUNG 1"1/4M - 3/4"F	REDUCTION 1"1/4M - 3/4"F	REDUCCION 1"1/4M - 3/4"F	REDUCTIE 1"1/4M - 3/4"F
32	F03151239	ROS. 27 X35X1,5 RAME -3/4"	3/4 COPPER WASHER	UNTERLEGSSCHEIBE KUPFER 3/4	RONDELLE CUIVRE 3/4	ARANDELA COBRE 3/4	SAIBA RAME 3/4
33	F03150011	NIPPLLO 3/4" - 3/8"	NIPPLE 3/4" - 3/8"	NIPPEL 3/4" - 3/8"	NIPPLE 3/4" - 3/8"	NIPLLE 3/4" - 3/8"	NIPLU 3/4" - 3/8"
34	F03151304	ACCUMULATORE 4,5L 210BAR	ACCUMULATOR 4,5L 210BAR	AKKUMULATOR 4,5L 210BAR	ACCUMULATEUR 4,5L 210BAR	ACUMULADOR 4,5L 210BAR	ACCUMULATOR 4,5L 210BAR

TAV. 040

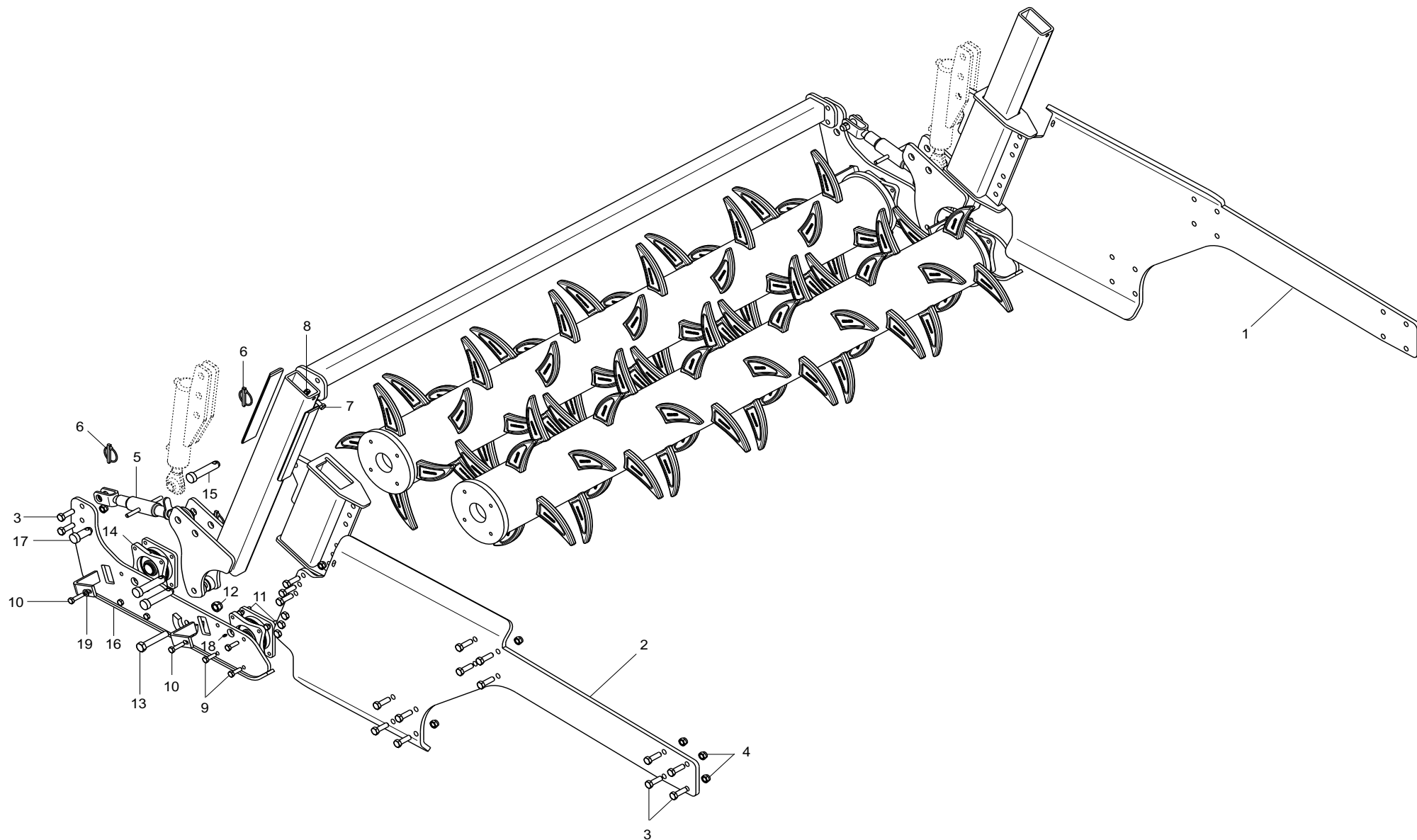

**DOPPIO RULLO POSTERIORE IDRAULICO / HYDRAULIC DOUBLE REAR ROLLER / HYDRAULISCHEN DOPPELTE NACHAUFWALZE /
DOUBLE ROULEAU POSTERIEUR HYDRAULIQUE / DOBLE ROLLO POSTERIOR HIDRAULICO / RULOU DUBLU POSTERIOR HIDRAULIC**

TAV. 040

Pos.	Cod.	Descrizione	Description	Description	Benennung	Descripcion	Descriere
1	R17815761	LAMA SUPPORTO REGOLAZIONE SX	SUPPORT BLADE ADJUSTMENT LEFT	HALTER. MESSERANPASSUNG RECHT	SUPPORT LAME REGLAGE GAUCHE	CUCHILLA SOPORTE AJUSTE IZQ.	LAMA SUPORT REGLARE SX
2	R17815751	LAMA SUPPORTO REGOLAZIONE DX	SUPPORT BLADE ADJUSTMENT RIGHT	HALTER. MESSERANPASSUNG LINK	SUPPORT LAME REGLAGE DROIT	CUCHILLA SOPORTE AJUSTE DERECHA	LAMA SUPORT AJUSTE DERECHA
3	F01020252	VITE M16X 2X 50 U5737 8.8 ZN	SCREW M16X 2X 50 U5737 8.8 ZN	SCHRAUBE M16X2X50 U5737 8.8 ZN	VIS M16X 2X 50 U5737 8.8 ZN	TORNILLO M16X2X50 U5737 8.8 ZN	SURUB M16X 2X 50 U5737 8.8 ZN
4	F01230085	DADO M16X 2 D982 8 ZN	NUT M16X 2 D982 8 ZN	MUTTER M16X 2 D982 8 ZN	ECROU M16X 2 D982 8 ZN	TUERCA M16X 2 D982 8 ZN	PIULITA M16X 2 D982 8 ZN
5	F02450022	TIRANTE L=330 L=490 D25,4 ZN	TIE ROD L=330 L=490 D25,4 ZN	SPANNST. L=330 L=490 D=25,4 ZN	TRINGLE L=330 L=490 D=25,4 ZN	TIRANTE L=330 L=490 D25,4 ZN	TIRANT L=330 L=490 D=25,4 ZN
6	F02200507	SPINA SCATTO D9 B/83 ZN	SNAP PIN D9 B/83 ZN	EINRASTSTIFT D9 B/83 ZN	FICHE A DETENTE D9 B/83 ZN	CLAVIJA DE MUELLE D9 B/83 ZN	STIFT RESORT D9 B/83 ZN
7	F01020508	VITE M12X1,75X25 U5739 8.8 ZN	SCREW M12X1,75X25 U5739 8.8 ZN	SCHR. M12X1,75X25 U5739 8.8 ZN	VIS M12X1,75X25 U5739 8.8 ZN	TORN. M12X1,75X25 U5739 8.8 ZN	SURUB M12X1,75X25 U5739 8.8 ZN
8	F01230059	DADO M12X1,75 D982 8 ZN	NUT M12X1,75 D982 8 ZN	MUTTER M12X1,75 D982 8 ZN	ECROU M12X1,75 D982 8 ZN	TUERCA M12X1,75 D982 8 ZN	PIULITA M12X1,75 D982 8 ZN
9	F01010288	VITE M12X1,25X35 U5740 8.8 ZN	SCREW M12X1,25X35 U5740 8.8 ZN	SCHR.M12X1,25X35 U5740 8.8 ZN	VIS M12X1,25X35 U5740 8.8 ZN	TORN.M12X1,25X35 U5740 8.8 ZN	SURUB M12X1,25X35 U5740 8.8 ZN
10	F01010292	VITE M12X1,25X45 U5740 8.8 ZN	SCREW M12X1,25X45 U5740 8.8 ZN	SCHRA.M12X1,25X45 U5740 8.8 ZN	VIS M12X1,25X45 U5740 8.8 ZN	TORN. M12X1,25X45 U5740 8.8 ZN	SURUB M12X1,25X45 U5740 8.8 ZN
11	F01020528	VITE M12X1,75X40 U5739 10.9 ZN	SCREW M12X1,75X40 U5739 10.9ZN	SCHR.M12X1,75X40 U5739 10.9 ZN	VIS M12X1,75X40 U5739 10.9 ZN	TORN.M12X1,75X40 U5739 10.9 ZN	SURUB M12X1,75X40 U5739 10.9ZN
12	F01230131	DADO M20X 2,5 D982 6 ZN	NUT M20X 2,5 D982 6 ZN	MUTTER M20X 2,5 D982 6 ZN	ECROU M20X 2,5 D982 6 ZN	TUERCA M20X 2,5 D982 6 ZN	PIULITA M20X 2,5 D982 6 ZN
13	F01020313	VITE M20X2,5X110 U5737 8.8 ZN	SCREW M20X2,5X110 U5737 8.8 ZN	SCHRA.M20X2,5X110 U5737 8.8 ZN	VIS M20X2,5X110 U5737 8.8 ZN	TORN. M20X2,5X110 U5737 8.8 ZN	SURUB M20X2,5X110 U5737 8.8 ZN
14	M43400468	CUSCINETTO OSCILANTE H.60 RIC.	BEARING OSCILLATING H.60 S.PAR	LAGER SCHWINGEND H.60 ERSATZT.	ROULEMENT OSCILLANT H.60 P.DET	COJINETE OSCILANTE H.60 P.REP.	RULMENT OSCILANT H.60 P.SCHIMB
15	F20100063	PERNO D25 L91 C40 ZN	BOLT D25 L91 C40 ZN	BOLZEN D25 L91 C40 ZN	BOULON D25 L91 C40 ZN	PERNO D25 L91 C40 ZN	BOLT D25 L91 C40 ZN
16	R17610160	SOPPORTO RULLO	ROLLER SUPPORT	HALLTERUNG WALTZE	ROULEAU SUPPORT	SOPORTE RODILLO	SUPORT RULOU
17	R17817910	PERNO D25 L55,5 ZN	BOLT D25 L55,5 ZN	BOLZEN D25 L55,5 ZN	BOULON D25 L55,5 ZN	PERNO D25 L55,5 ZN	BOLT D25 L55,5 ZN
18	F01100011	ING.M 6X1 7663-A 9SMNPB28 ZN	GREASE NIPPLE M6X1 7663-A ZN	SCHMIERBUECHE M6X1 7663-A ZN	GRAISS. A BILLE M6X1 7663A ZN	ENGRAS. DE ESFERAS M6X1 7663-A	ING.M 6X1 7663-A 9SMNPB28 ZN
19	F01410076	RONDELLA D12 U6592 ZN	WASHER D12 U6592 ZN	SCHEIBE D12 U6592 ZN	RONDELLE D12 U6592 ZN	ARANDELA D12 U6592 ZN	SAIBA D12 U6592 ZN

TAV. 050

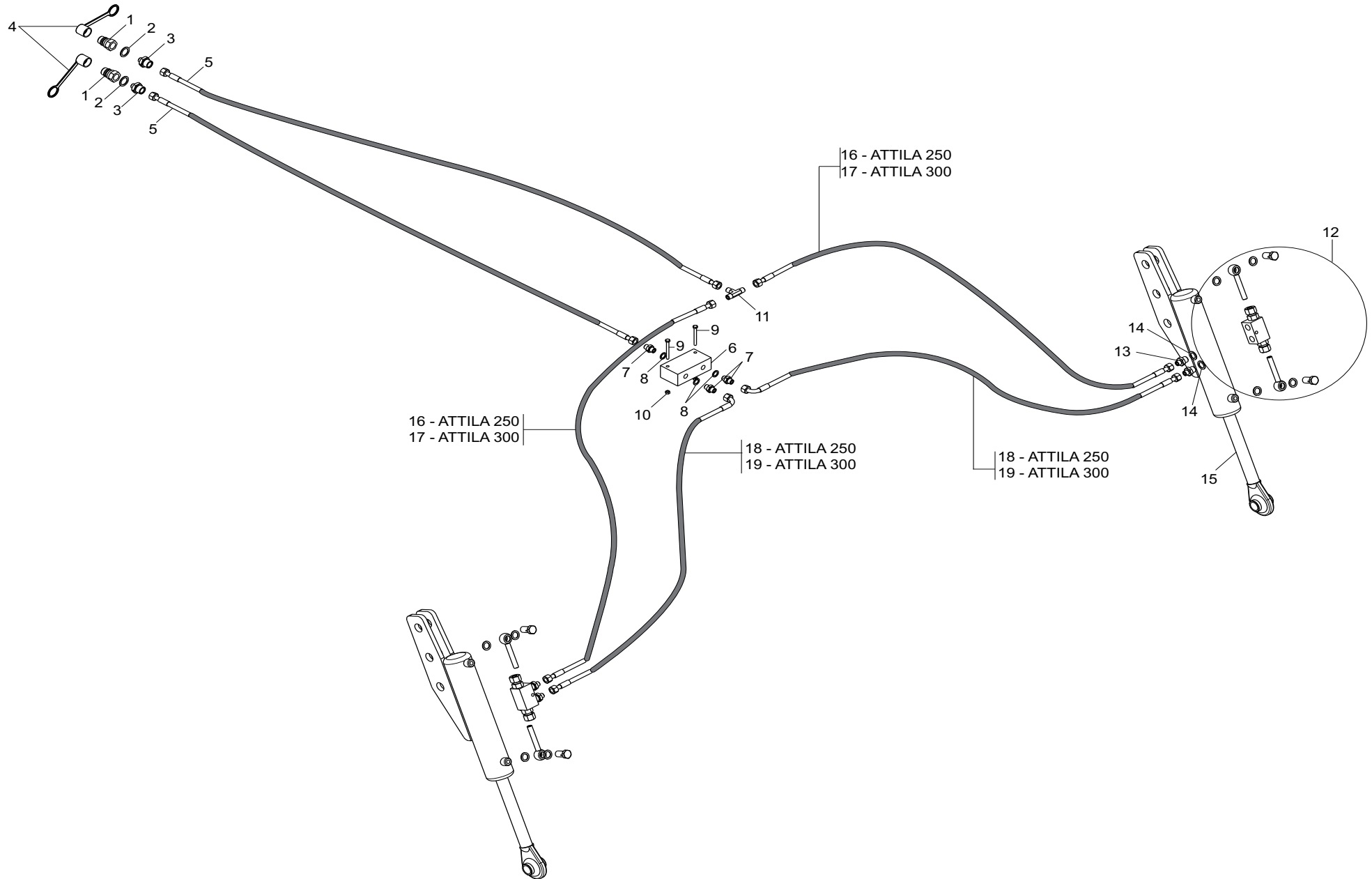

**IMPIANTO OLEODINAMICO RULLO / HYDRAULIC PLANT ROLLER / HYDRAULISCHEN ANZUG WALZE /
 INSTALLATION HYDRAULIQUE ROULEAU / INSTALACION HIDRAULICA ROLLO / INSTALAȚIE HIDRAULICĂ RULOU**

TAV. 050

Pos.	Cod.	Descrizione	Description	Description	Benennung	Descripcion	Descriere
1	F03150935	INNESTO RAP.MASCH.1/2 A VALV.	QUICK CONNECT MALE CONE 1/2	SCHNELLKUPP.GEWINDE KONISC 1/2	CONNEXION RAPIDE MALE CONE 1/2	ACOPLAMIEN.RAP.MACHO CONO 1/2	CONECTARE RAPIDA TATA 1/2 VAL.
2	F03151237	ROSSETA RAME 21 X27X1,5 1/2	COPPER WASHER 21X27X1,5 1/2	SCHEIBE KUPFER 21X27X1,5 1/2	RONDELLE CUIVRE 21X27X1,5 1/2	ARANDELA COBRE 21X27X1,5 1/2	SAIBA PLANA 21X27X1,5 1/2
3	F03150211	NIPLO MM CIL-CIL 1/2-1/4 ZN	NIPLE MM 1/4-1/2 ZN	NIPLE GG 1/4-1/2 ZN	NIPLE MM 1/4-1/2 ZN	NIPLE MM 1/4-1/2 ZN	NIPLU MM 1/4-1/2 ZN
4	F05150325	CAPPUCCIO F. 1/2 ROSSO	COVER CONNECT F 1/2 RED	DECKEL W 1/2 SCHNELLKUPP. ROT	COUVERCLE CONNEXION F 1/2 ROSE	PAC PROTECCION F 1/2 ROJO	CAPAC PROTECTIE F 1/2 ROSU
5	R17817920	TUBO 1/4 FF L=2000	PIPE 1/4 FF L=2000	ROHR 1/4 FF L=2000	TUBE 1/4 FF L=2000	TUBO 1/4 FF L=2000	TUB 1/4 FF L=2000
6	F03151044	DIVISORE DI FLUSSO A 2 VIE	FLOW DIVISOR	OELVERTEILER	DIVISEUR DE FLUX	DIVISOR DE FLUJO	DIVIZOR FLUX
7	F03150266	NIPLO MM CIL-CIL 1/4-1/4 ZN	NIPPLE GALV.CYL.MALE 1/4 ZN	NIPPELZYL.1/4 ZN	NIPPLE MALE CYL. 1/4 ZN	NIPLE MACHO CIL.1/4 ZN	NIPLU TATA CIL.1/4 ZN
8	F03151238	ROSSETA RAME 13X19X1,5 -1/4"	COPPER WASHER 13X19X1,5 -1/4"	SCHEIBE KUPFER 13X19X1,5 -1/4"	RONDELLE CUIVRE 13X19X1,5 -1/4"	ARANDELA COBRE 13X19X1,5 -1/4"	SAIBA PLANA 13X19X1,5 -1/4"
9	F01020416	VITE M 6X 1X 55 U5739 8.8 ZN	SCREW M6X 1X 55 U5739 8.8 ZN	SCHRAUBE M6X1X 55 U5739 8.8 ZN	VIS M 6X 1X 55 U5739 8.8 ZN	TORNILLO M6X1X55 U5739 8.8 ZN	SURUB M6X 1X 55 U5739 8.8 ZN
10	F01220011	DADO M6X 1 D980 8 ZN	NUT M6X1 D980 8 ZN	MUTTER M6X1 D980 8 ZN	ECROU M6X1 D980 8 ZN	TUERCA M6X1 D980 8 ZN	PIULITA M6X1 D980 8 ZN
11	F03151219	RACCORDO -T- MASCHIO 1/4 ZN	MALE T-UNION 1/4 ZN	ANSCHLUSSTsCK-T-GEWINDE 1/4 ZN	RACCORD -T- MALE 1/4 ZN	UNI N -T- MACHO 1/4 ZN	RACORD -T- TATA 1/4 ZN
12	F03151158	KIT VALVOLA BLOCCO 3/8 7014200	KIT CHECK VALVES 3/8 7014200	KIT RUCKSCHLAGVENTIL 3/8	KIT CLAPET DE BLOCAGE 3/8	KIT VALVULA ANTIRATORNO 3/8	KIT VALVA BLOC 3/8 7014200
13	F03150310	NIPLO MM CIL-CIL 3/8-1/4 ZN	NIPPLE CYL.MALE3/8-1/4 ZN	NIPPELZYL.3/8-1/4 ZN	NIPPLE MALE CYL.3/8-1/4 ZN	NIPLE MACHO CIL.3/8-1/4 ZN	NIPLU TATA CIL.3/8-1/4 ZN
14	F03151240	ROSSETA RAME 17X 23X1,5 3/8"	COPPER WASHER 17X23X1,5 3/8"	SCHEIBE KUPFER 17X23X1,5 3/8"	RONDELLE CUIVRE 17X23X1,5 3/8"	ARANDELA COBRE 17X23X1,5 3/8"	SAIBA PLANA 17X23X1,5 3/8"
15	R17811481	CILINDRO 30X70 - 280	CYLINDER 30X70 - 280	ZYLINDER 30X70 - 280	CYLINDRE 30X70 - 280	CILINDRO 30X70 - 280	CILINDRU 30X70 - 280
16	G17915100	TUBO 1/4 F-F L.2800	PIPE 1/4 F-F L.2800	ROHR 1/4 F-F L.2800	TUBE 1/4 F-F L.2800	TUBO 1/4 F-F L.2800	TUB 1/4 F-F L.2800
17	R17814480	TUBO 1/4R2 F1/4-F1/4 L=3000	PIPE 1/4R2 F1/4-F1/4 L=3000	ROHR 1/4R2 F1/4-F1/4 L=3000	TUBE 1/4R2 F1/4-F1/4 L=3000	TUBO 1/4R2 F1/4-F1/4 L=3000	TUB 1/4R2 F1/4-F1/4 L=3000
18	G15210551	TUBO 1/4R2 C-F L.2750 LM	PIPE 1/4R1 C-F L.2750 LM	ROHR 1/4R1 C-F L.2750 LM	TUBE 1/4R1 C-F L. 2750 LM	TUBO 1/4R1 C-F L.2750 LM	TUB 1/4R2 C-F L.2750 LM
19	G15210631	TUBO 1/4R2 CF1/4- F1/4 3000	PIPE 1/4R2 CF1/4- F1/4 3000	ROHR 1/4R2 CF1/4- F1/4 3000	TUBE 1/4R2 CF1/4- F1/4 3000	TUBO 1/4R2 CF1/4- F1/4 3000	TUB 1/4R2 CF1/4- F1/4 3000

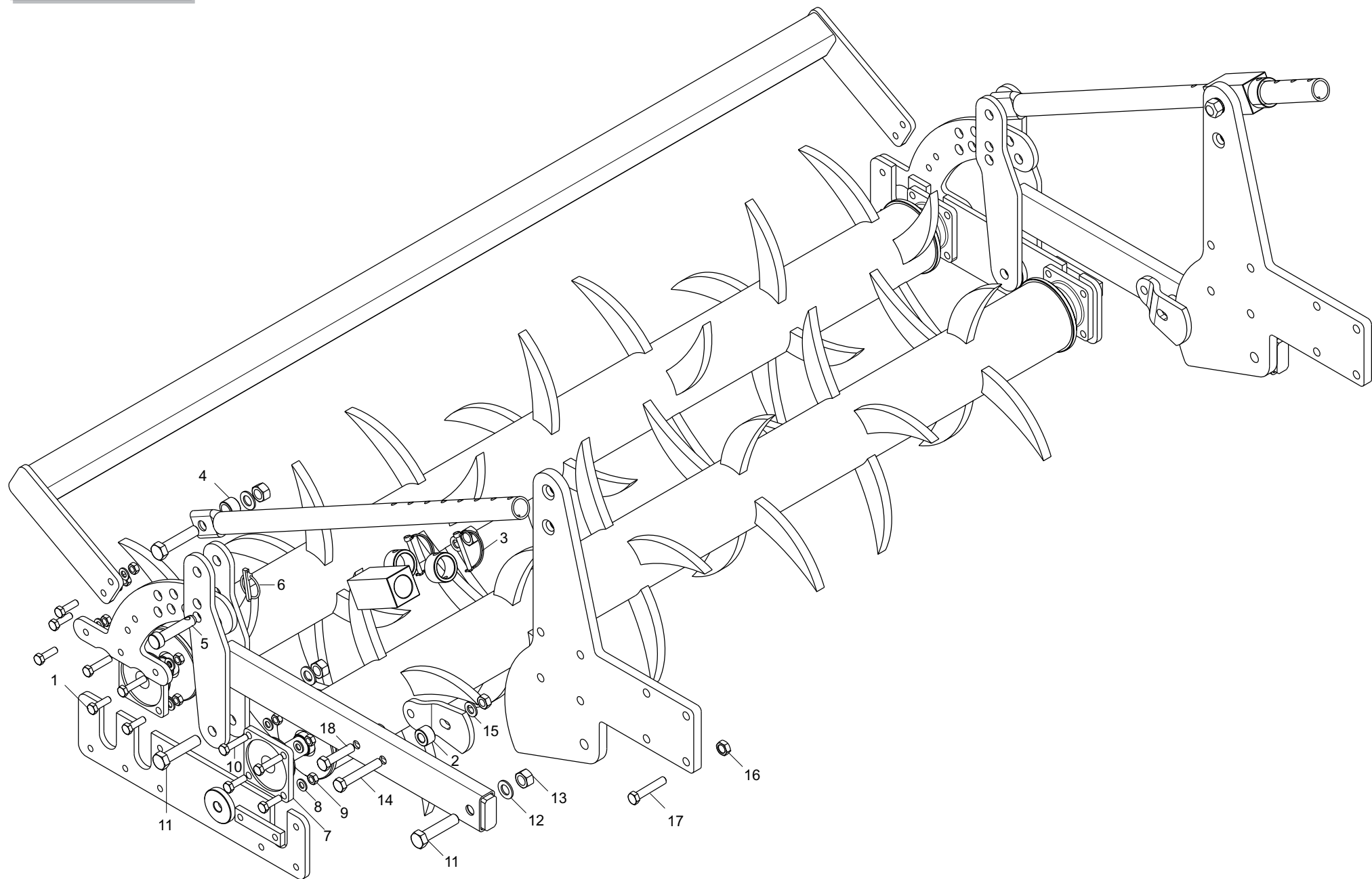

DOPPIO RULLO POSTERIORE MECCANICO / MECHANICAL DOUBLE REAR ROLLER / MECHANISCHE DOPPELTE NACHAUFWALZE / DOUBLE ROULEAU POSTERIEUR MECANIQUE / DOBLE ROLLO POSTERIOR MECANICO / RULOU DUBLU POSTERIOR MECANIC ATILA 250-300

TAV. 060

Pos.	Cod.	Descrizione	Description	Description	Benennung	Descripcion	Descriere
1	F01020152	VITE M12X1,75X40 U5737 8.8 ZN	SCREW M12X1,75X40 U5737 8.8 ZN	SCHR.M12X1,75X 40 U5737 8.8 ZN	VIS M12X1,75X 40 U5737 8.8 ZN	TORN.M12X1,75X 40 U5737 8.8 ZN	SURUB M12X1,75X40 U5737 8.8 ZN
2	R17813230	BOCCOLA	BUSHING	BUCHSE	BUSHING	CASQUILLO	BUCSA DISTANTATOARE
3	F02200562	SPINA SICUR. D.8X70 ZN	SAFETY PIN D.8X 70 ZN	SCHERSTIFT D.8X 70 ZN	FICHE EL. D.8X70 ZN	CLAVIJA D.8X 70 ZN	STIFT DE SIGURANTA D.8X70 ZN
4	R17812000	BOCCOLA 21,7X33,7X23 ZN	BUSHING 21,7X33,7X23 ZN	BUCHSE 21,7X33,7X23 ZN	BUSHING 21,7X33,7X23 ZN	CASQUILLO 21,7X33,7X23 ZN	BUCSA 21,7X33,7X23 ZN
5	R17813310	PERNO D20 L90 ZN	BOLT D20 L90 ZN	BOLTZEN D20 L90 ZN	BOULON D20 L90 ZN	PERNO D20 L90 ZN	BOLT D20 L90 ZN
6	F02200507	SPINA SCATTO D9 B/83 ZN	SNAP PIN D9 B/83 ZN	EINRASTSTIFT D9 B/83 ZN	FICHE A DETENTE D9 B/83 ZN	CLAVIJA DE MUELLE D9 B/83 ZN	STIFT RESORT D9 B/83 ZN
7	F04100073	SUPPORTO CUSCINETTO FY35TF	BEARING SUPPORT FY35TF	LAGERHALTERUNG FY35TF	SUPPORT ROULEMENT FY35TF	SOPORTE COJINETE FY35TF	SUPORT RULMENT FY35TF
8	F01410076	RONDELLA D12 U6592 ZN	WASHER D12 U6592 ZN	SCHEIBE D12 U6592 ZN	RONDELLE D12 U6592 ZN	ARANDELA D12 U6592 ZN	SAIBA D12 U6592 ZN
9	F01230059	DADO M12X1,75 D982 8 ZN	NUT M12X1,75 D982 8 ZN	MUTTER M12X1,75 D982 8 ZN	ECROU M12X1,75 D982 8 ZN	TUERCA M12X1,75 D982 8 ZN	PIULITA M12X1,75 D982 8 ZN
10	F01020160	VITE M12X1,75X60 U5737 8.8 ZN	SCREW M12X1,75X60 U5737 8.8 ZN	SCHRA.M12X1,75X60 U5737 8.8 ZN	VIS M12X1,75X60 U5737 8.8 ZN	TORN. M12X1,75X60 U5737 8.8 ZN	SURUB M12X1,75X 60 5737 8.8 ZN
11	F01020325	VITE M20X2,5X90 U5737 10.9 ZN	SCREW M20X2,5X90 U5737 10.9 ZN	SCHR.M20X2,5X90 U5737 10.9 ZN	VIS M20X2,5X90 U5737 10.9 ZN	TORN. M20X2,5X90 U5737 10.9 ZN	SURUB M20X2,5X90 U5737 10.9 ZN
12	F01410124	ROSSETA M20 21X 37X 3 U6592 ZN	WASHER M20 21X37X3 U6592 ZN	SCHEIBE M20 21X37X3 U6592 ZN	RONDELLE M20 21X37X3 U6592 ZN	ARANDELA M20 21X37X3 U6592 ZN	SAIBA M20 21X37X3 U6592 ZN
13	F01230131	DADO M20X 2,5 D982 6 ZN	NUT M20X 2,5 D982 6 ZN	MUTTER M20X 2,5 D982 6 ZN	ECROU M20X 2,5 D982 6 ZN	TUERCA M20X 2,5 D982 6 ZN	PIULITA M20X 2,5 D982 6 ZN
14	F01020285	VITE M16X2X100 U5737 8.8 ZN	SCREW M16X2X100 U5737 8.8 ZN	SCHRA. M16X2X100 U5737 8.8 ZN	VIS M16X2X100 U5737 8.8 ZN	TORN. M16X2X100 U5737 8.8 ZN	SURUB M16X2X100 U5737 8.8 ZN
15	F01410100	ROSSETA M16 17X 30X3 U6592 ZN	WASHER M16 17X30X3 U6592 ZN	SCHEIBE M16 17X30X3 U6592 ZN	RONDELLE M16 17X30X3 U6592 ZN	ARANDELA M16 17X30X3 U6592 ZN	SAIBA M16 17X 30X 3 U6592 ZN
16	F01230085	DADO M16X 2 D982 8 ZN	NUT M16X 2 D982 8 ZN	MUTTER M16X 2 D982 8 ZN	ECROU M16X 2 D982 8 ZN	TUERCA M16X 2 D982 8 ZN	PIULITA M16X 2 D982 8 ZN
17	F01020260	VITE M16X2X70 U5739 8.8 ZN	SCREW M16X2X70 U5737 8.8 ZN	SCHRAUBE M16X2X70 U5737 8.8 ZN	VIS M16X2X70 U5737 8.8 ZN	TORNILLO M16X2X70 U5737 8.8 ZN	SURUB M16X2X70 U5739 8.8 ZN
18	F01020262	VITE M16X 2X 80 U5737 8.8 ZN	SCREW M16X2X80 U5737 8.8 ZN	SCHRAUBE M16X2X80 U5737 8.8 ZN	VIS M16X2X80 U5737 8.8 ZN	TORNILLO M16X2X80 U5737 8.8 ZN	SURUB M16X 2X 80 U5737 8.8 ZN

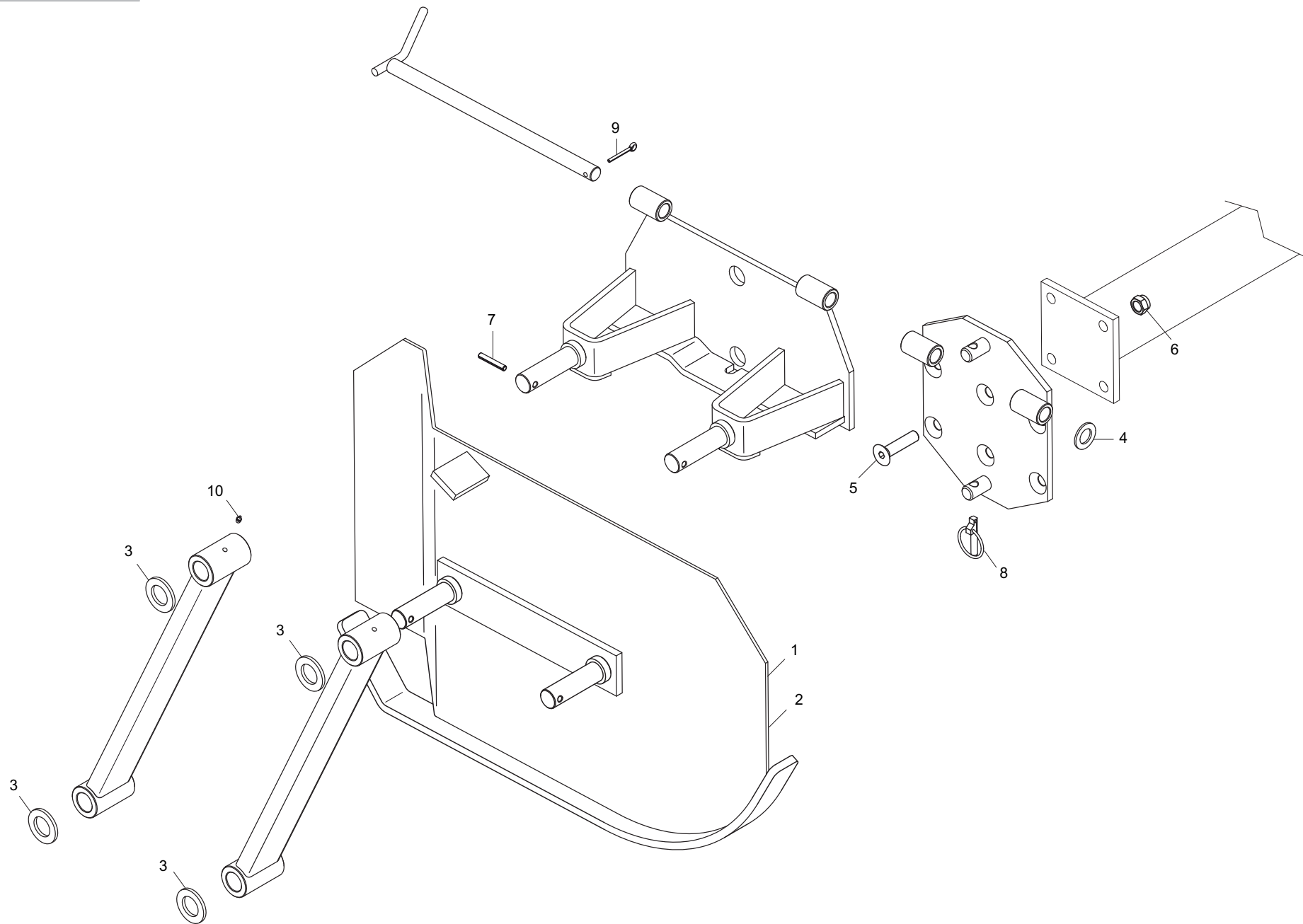

**BANDINELLA LATERALE MECCANICA / MECHANICAL STRIP CLOD / MECHANISCHE STREIFEN /
MECANIQUE BANDE / BANDAS MECANICA / LIMITATOR LATERAL DE BRAZDĂ MECANIC**

TAV. 070

Pos.	Cod.	Descrizione	Description	Description	Benennung	Descripcion	Descriere
1	R17811821	BANDELLA DX	PROTECTION DX	SCHUTZ DX	PROTECTION DX	PROTECCION DX	ANSAMBLU PROTECTIE DX
2	R17811831	BANDELLA SX	PROTECTION SX	SCHUTZ SX	PROTECTION SX	PROTECCION SX	ANSAMBLU PROTECTIE SX
3	G18700570	RONDELLA 20X54X6	WASHER 20X54X6	SCHLEIBE 20X54X6	RONDELLE 20X54X6	ARANDELA 20X54X6	SAIBA 20X54X6
4	F01410135	ROSSETA M22 23X39X3 U6592 ZN	WASHER M22 23X39X3 U6592 ZN	SCHLEIBE M22 23X39X3 U6592 ZN	RONDELLE M22 23X39X3 U6592 ZN	ARANDELA M22 23X39X3 U6592 ZN	SAIBA M22 23X39X3 U6592 ZN
5	F01030152	VITE M16X2X70 U5933 8.8 ZN	SCREW M16X2X70 U5933 8.8 ZN	SCHRAUBE M16X2X70 U5933 8.8 ZN	VIS M16X2X70 U5933 8.8 ZN	TORNILLO M16X2X70 U5933 8.8 ZN	SURUB M16X 2X 70 U5933 8.8 ZN
6	F01230085	DADO M16X 2 D982 8 ZN	NUT M16X 2 D982 8 ZN	MUTTER M16X 2 D982 8 ZN	ECROU M16X 2 D982 8 ZN	TUERCA M16X 2 D982 8 ZN	PIULITA M16X 2 D982 8 ZN
7	F02100144	SPINA EL. D8 L50 D1481 C70 BR	ELASTIC PIN D8 L50 D1481 C70BR	SPANNSTIFT D8 L50 D1481 C70BR	FICHE EL. D8 L50 D1481 C70 BR	CLAVIJA D8 L50 D1481 C70 BR	STIFT EL. D8 L50 D1481 C70 BR
8	F02200507	SPINA SCATTO D9 B/83 ZN	SNAP PIN D9 B/83 ZN	EINRASTSTIFT D9 B/83 ZN	FICHE A DETENTE D9 B/83 ZN	CLAVIJA DE MUELLE D9 B/83 ZN	STIFT RESORT D9 B/83 ZN
9	F02200229	COPIGLIA 5X 45 U1336 ZN	SPLIT PIN 5X 45 U1336 ZN	SPLINT 5X 45 U1336 ZN	GOUPILLE 5 X45 1336 ZN	PASADOR 5 X45 U1336 ZN	SPLINT 5X 45 U1336 ZN
10	F01100048	ING.M 8X1,25 7663A 9SMNPB28 ZG	GREASE NIPPLE M8X1,25 U7663A	SCHMIERBUECHSE M8X1,25 7663A	GRAISSEUR A BILLES M8X1,25	ENGRAS. DE ESFERAS M8 X 1,25 A	INGRANS. SFERIC M8X1,25 7663A

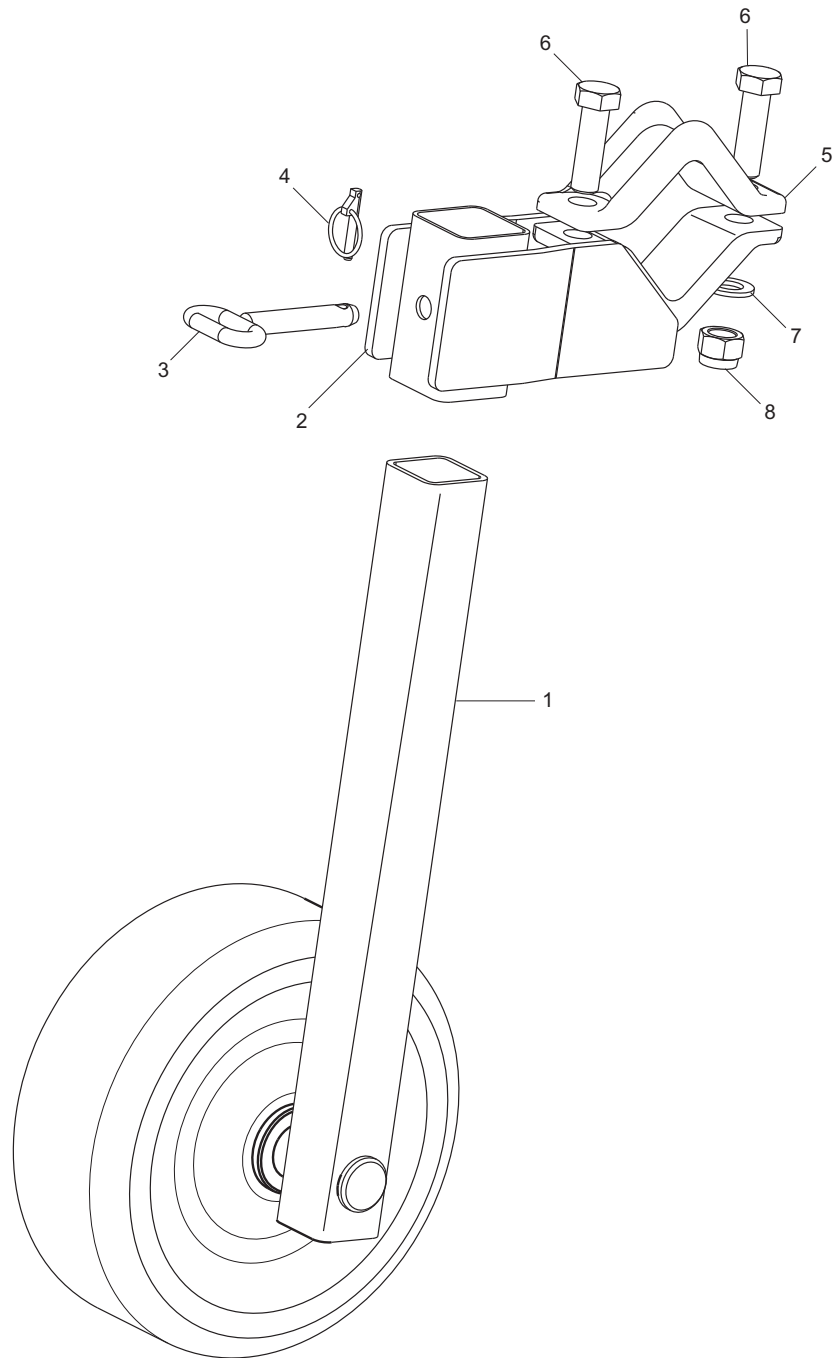

**RUOTA DI PROFONDITÀ / DEPTH WHEEL / BLOCK TIEFE / ROUE DE PROFONDEUR /
RUEDA DE PROFUNDIDAD / ROATĂ DE ADÂNCIME**

TAV. 080

Pos.	Cod.	Descrizione	Description	Description	Benennung	Descripcion	Descriere
1	R18012160	ASSIEME RUOTA	ASSEMBLY WHEEL	TIEFENRAD	ASSEMBLEE ROUE	ASAMBLEA RUEDA	ANSAMBLU ROATA
2	R17815720	ASSIEME SUPPORTO	ASSEMBLY SUPPORT	HALTERUNG ZUSAMMENBAU	ASSEMBLEE SUPPORT	ASAMBLEA SUPPORTO	ANSAMBLU SUPORT
3	R17810440	PERNO D20 L105 ZN	BOLT D20 L105 ZN	BOLZEN D20 L105 ZN	BOULON D20 L105 ZN	PERNO D20 L105 ZN	BOLT D20 L105 ZN
4	F02200507	SPINA SCATTO D9 B/83 ZN	SNAP PIN D9 B/83 ZN	EINRASTSTIFT D9 B/83 ZN	FICHE A DETENTE D9 B/83 ZN	CLAVIJA DE MUELLE D9 B/83 ZN	STIFT RESORT D9 B/83 ZN
5	R17811170	SCONTRO PER TUBO 100	FLANGE 100	ANSCHLAG 100	BUTEE 100	ELEMENTO DE EMPALME 100	BRIDA FIXARE TEAVA 100
6	F01020343	VITE M24X 3X 80 U5737 10.9 ZN	SCREW M24X 3X 80 U5737 10.9 ZN	SCHR. M24X 3X 80 U5737 10.9 ZN	VIS M24X 3X 80 U5737 10.9 ZN	TORN. M24X 3X 80 U5737 10.9 ZN	SURUB M24X 3X 80 U5737 10.9 ZN
7	G18701590	RONDELLA 25 X35 X2,5 ZN	WASHER 25 X35 X2,5 ZN	SCHEIBE 25 X35 X2,5 ZN	RONDELLE 25 X35 X2,5 ZN	ARANDELA 25 X35 X2,5 ZN	SAIBA 25X 35X 2,5 ZN
8	F01230144	DADO M24X 3 D982 8 ZN	NUT M24X 3 D982 8 ZN	MUTTER M24X 3 D982 8 ZN	ECROU M24X 3 D982 8 ZN	TUERCA M24X 3 D982 8 ZN	PIULITA M24X 3 D982 8 ZN

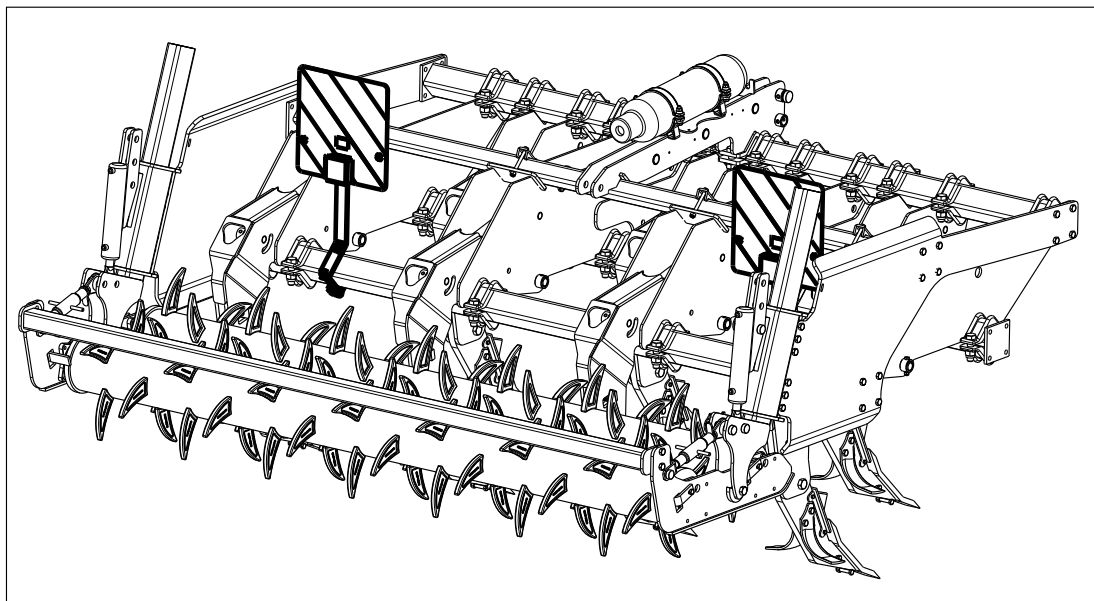
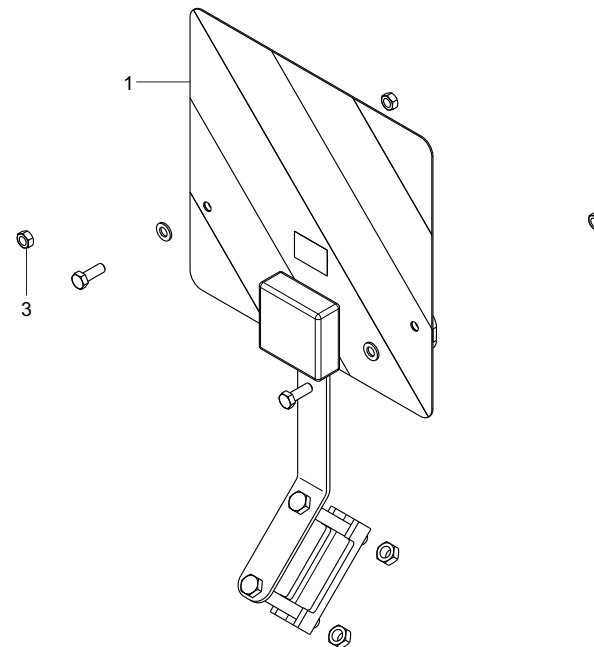
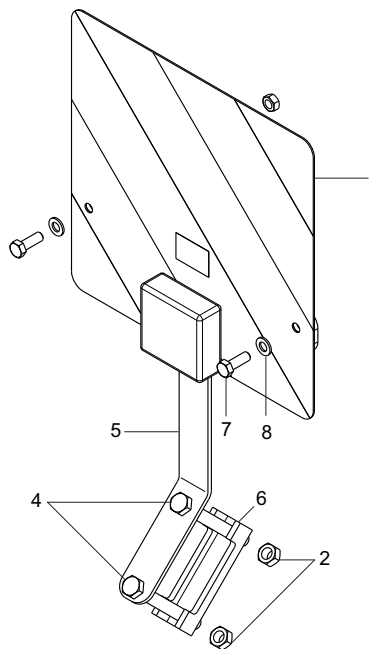

KIT LUCI / LIGHTING KIT / LICHTER KIT / KIT D'ECLAIRAGE / KIT DE ILUMINACION / LIT LUMINI
TAV. 090

Pos.	Cod.	Descrizione	Description	Description	Benennung	Descripcion	Descriere
1	M62100817	SET INSTALATIE ELECTRICA	ELECTRIC KIT	ELEKTRISCHES WERKZEUG	EQUIPEMENT ELECTRIQUE	ELEKTRISCHES WER	SET INSTALATIE ELECTRICA
2	F01230085	DADO M16X 2 D982 8 ZN	NUT M16X 2 D982 8 ZN	MUTTER M16X 2 D982 8 ZN	ECROU M16X 2 D982 8 ZN	TUERCA M16X 2 D982 8 ZN	PIULITA M16X 2 D982 8 ZN
3	F01220047	DADO M12X1,25 D980 8 ZN	NUT M12X1,25 D980 8 ZN	MUTTER M12X1,25 D980 8 ZN	ECROU M12X1,25 D980 8 ZN	TUERCA M12X1,25 D980 8 ZN	PIULITA M12X1,25 D980 8 ZN
4	F01020270	VITE M16X 2X150 U5737 8.8 ZN	SCREW M16X 2X150 U5737 8.8 ZN	SCHR. M16X 2X150 U5737 8.8 ZN	VIS M16X 2X150 U5737 8.8 ZN	TORN. M16X 2X150 U5737 8.8 ZN	SURUB M16X 2X150 U5737 8.8 ZN
5	R17640090	PIASTRA SUPPORTO LIT LUCI	BLADE SUPPORT KIT LIGHTS	MESSER HALTERUNG KIT LUCE	LAMA SUPPORT KIT LUCE	CUCHILLA SOPORTE KIT LUCE	PLACA SUPORT KIT LUMINI
6	G13710560	SCONTRO "U" 100 SP.8 2F16 118	FLANGE 'U' SP.8 100 2F16 118	ANSCHLAG 'U' 100 SP.8 2F16 118	BRIDE 'U' 100 SP.8 2F16 118	EL.DE EMPALME 'U' 100 2F16 118	BRIDA 'U' 100 SP.8 2F16 118
7	F01010050	VITE M12X1,25X35 U5738 8.8 ZN	SCREW M12X1,25X35 U5738 8.8 ZN	SCHRA. M12X1,25X35 U5738 8.8ZN	VIS M12X1,25X35 U5738 8.8 ZN	TORN. M12X1,25X35 U5738 8.8 ZN	SURUB M12X1,25X35 U5738 8.8 ZN
8	F01410076	RONDELLA D12 U6592 ZN	WASHER D12 U6592 ZN	SCHEIBE D12 U6592 ZN	RONDELLE D12 U6592 ZN	ARANDELA D12 U6592 ZN	SAIBA D12 U6592 ZN

**USATE SEMPRE RICAMBI ORIGINALI
ALWAYS USE ORIGINAL SPARE PARTS
IMMER DIE ORIGINAL-ERSATZTEILE VERWENDEN
EMPLOYEZ TOUJOURS LES PIECES DE RECHANGE ORIGINALES
UTILIZAR SIEMPRE REPUESTOS ORIGINALES
UTILIZAȚI ÎNTOTDEAUNA PIESE DE SCHIMB ORIGINALE**

MASCHIO GASPARDO



MASCHIO GASPARDO

R19530121

MASCHIO GASPARDO SpA

Sede legale e stabilimento produttivo
Via Marcello, 73 - 35011 Campodarsego (Padova) - Italy
Tel. +39 049 9289810
Fax +39 049 9289900
Email: info@maschio.com
www.maschionet.com

MASCHIO DEUTSCHLAND GMBH

Äußere Nürnberger Straße 5
D - 91177 Thalmässing ng
Deutschland
Tel. +49 (0) 9173 79000
Fax +49 (0) 9173 790079

MASCHIO FRANCE Sarl

1, Rue de Mérignan ZA
F - 45240 La Ferte St. Aubin
France
Tel. +33 (0) 2.38.64.12.12
Fax +33 (0) 2.38.64.66.79

MASCHIO IBERICA S.L.

Calle Cabernet, 10
Poligono Industrial Clot de Moja
Olerdola - 08734 Barcelona
Tel. +34 93.81.99.058
Fax +34 93.81.99.059

MASCHIO-GASPARDO USA Inc

120 North Scott Park Road
Eldridge, IA 52748 - USA
Ph. +1 563 2859937
Fax +1 563 2859938
e-mail: info@maschio.us

**MASCHIO GASPARDO SpA
Stabilimento produttivo**

Via Mussons, 7 - 33075
Morsano al Tagliamento (PN) - Italy
Tel. +39 0434 695410
Fax +39 0434 695425
Email: info@gaspardo.it

ООО МАСКИО-ГАСПАРДО РУССИЯ

404126, Россия, Волгоградская область,
г.Волжский, ул.Пушкина, 117 *6*.
Тел.: +78443525065
факс: +78443525064
e-mail: info@maschio.ru
<http://www.maschionet.com>

MASCHIO GASPARDO ROMANIA SRL

Strada Înfrățirii, Nr. 155
315100 Chișineu - Criș
Tel. +40 257 30 70 30
Fax +40 257 30 70 40
e-mail: info@maschio.com
<http://www.maschio.com>

MASCHIO MIDDLE EAST

P.O. Box 922388
Amman, 11192 Jordan
Tel. 962 605511384
Fax 962 6 5538398
e-mail: tahaeng@nets.com.jo

**GASPARDO-MASCHIO TURCHIA
MASCHIO-GASPARDO CANADA Inc
MASCHIO-GASPARDO CINA
MASCHIO-GASPARDO POLAND
MASCHIO-GASPARDO UCRAINA
GASPARDO BIELORUSSIA
MASCHIO-GASPARDO KOREA**