

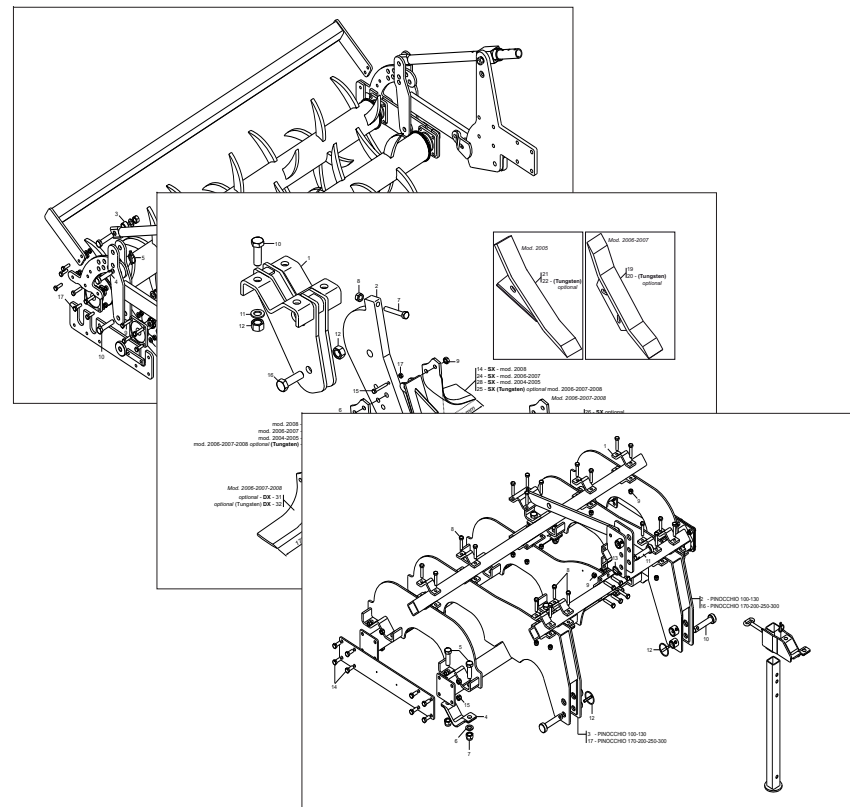

# MASCHIO GASPARDO

## MASCHIO GASPARDO ROMANIA S.R.L.



# PINOCCCHIO

Cod: R19530790 06 / 2008

- \*) Valido per Paesi UE
- \*) Valid for EU member countries
- \*) Gilt für EU-Mitgliedsländer
- \*) Valable dans le Pays UE
- \*) Válido para Países UE
- \*) Valabil pentru țările UE

- IT** PARTI DI RICAMBIO
- EN** SPARE PARTS
- DE** ERSATZTEILE
- FR** PIÈCES DÉTACHÉES
- ES** PIEZAS DE REPUESTO
- RO** PIESE DE SCHIMB

## PARTI DI RICAMBIO

Le ordinazioni delle parti di ricambio vanno fatte presso i nostri concessionari di zona e devono essere sempre corredate dalle seguenti indicazioni:

- **Tipo, modello e numero di matricola dell'attrezzatura.** Tali dati sono stampigliati nell'apposita targhetta di cui è dotata ogni attrezzatura.
  - **Numero di codice della parte richiesta** rilevabile dal catalogo ricambi.
  - **Descrizione del particolare e quantità richiesta.**
  - **Numero della tavola.**
  - **Mezzo di trasporto.** Nel caso questa voce non sia specificata, la Ditta Costruttrice, pur dedicando a questo servizio una particolare cura, non risponde di eventuali ritardi di spedizione dovuti a cause di forza maggiore.
- Le spese di trasporto si intendono sempre a carico del destinatario. La merce viaggia a rischio e pericolo del committente anche se venduta franco destino.

**NOTA:** Il termine **(Dx) Destro** o **(Sx) Sinistro** della macchina o di parti di essa, è inteso guardando la macchina dalla parte posteriore. Le eccezioni saranno indicate.

## SPARE PARTS

*Orders must be transmitted through our area dealers and should always include the following indications:*

- **Type, model and serial number of the machine.** *These data are punched on the data plate with which every implement is equipped.*
- **Code number of the required spare part.** *This will be found in the spare parts catalogue.*
- **Description of the part and required quantity.**
- **Table number.**
- **Means of dispatch.** *If this item is not indicated, the Manufacturer, while dedicating particular care to this service, shall not be held responsible for delays in delivery caused by cases of force majeure.*

*Transport expenses shall always be at the consignee's charge. The goods travel at the purchaser's risk and peril even when sold ex destination.*

**NOTE:** *The symbols (Dx) right and (Sx) left, concerning the machine or single parts of it, are referred, as in the figure, to a rear view of them. Exceptions will be indicated.*

## ERSATZTEILE

Die Bestellungen müssen bei unseren Gebietshändler angegeben werden. Bei der Bestellung sind stets die folgenden Angaben zu machen:

- **Typ, Modell und Serien-Nummer des Geräts.** Diese Daten stehen auf dem Typenschild, mit dem jedes Gerät versehen ist.
- **Artikel Nr. der erforderlichen Ersatzteile.** Diese stehen im Ersatzteil-Katalog.
- **Beschreibung des Ersatzteils und die erforderliche Stückzahl.**
- **Tafelnummer.**
- **Versandmittel.** Wenn dieser Punkt nicht spezifiziert wird, haftet die Herstellerfirma nicht für etwaigen Lieferverzug aufgrund höherer Gewalt, auch wenn er diesen Service besonders aufmerksam abwickelt.

Die Frachtkosten gehen dagegen immer zu Lasten des Empfängers. Die Ware reist auf Gefahr und Risiko des Auftraggebers, auch wenn frei Haus Verkauft vereinbart worden ist.

**N.B.:** Die Merkzeichen **(Dx) rechts** und **(Sx) links** betreffen eine rückwärtige Aussicht der Maschine oder Teile von ihr (siehe Bild). Ausnahmen werden gezeitigt.

## PIECES DÉTACHÉES

*Les ordres doivent être effectués auprès de nos concessionnaires de zone en précisant les indications suivantes:*

- **Type, modèle et numéro de série de la machine.** *Ces données sont gravées sur la plaque d'identification de chaque outil.*
- **Numéro de code de la pièce détachée** *indiqué sur le catalogue des pièces détachées.*
- **Description de la pièce et quantité requise.**
- **Numéro de plan.**
- **Moyen d'expédition.** *Si cette rubrique n'est pas indiquée, le Constructeur, bien que soucieux de ce service, ne répond pas des retards d'expédition pour des causes de force majeure.*

*Les frais de transport sont toujours à la charge du destinataire. La marchandise voyage aux risques et périls de l'acheteur même si vendue franco de port.*

**N.B.:** *Les références (Dx) droit et (Sx) gauche de la machine ou des parties de la même, est entendue, comme de la figure, en regardant la machine de derriere dans le sens de marche.*

## RESPUESTOS

Los pedidos han de efectuarse en nuestros consesionarios de zona y deben incluir siempre las siguientes indicaciones:

- **Tipo, modelo y número de matrícula del equipo.** Dichos datos están impresos en la relativa placa presente en el equipo.
- **Número de código de la parte requerida** presente en el catálogo respuestas.
- **Descripción de la pieza y cantidad requerida.**
- **Numero de ilustración.**
- **Medio de transporte.** En caso que este ítem no esté especificado, el Fabricante, aún prestando la debidas consideraciones para este aspecto, no responde por eventuales retardos de env'o debidos a causas de fuerza mayor.

Los gastos de transporte se consideran siempre a cargo del destinatario. La mercadería viaja bajo riesgo y peligro del comprador, incluso cuando se vende franco destino.

**N.B.:** La referencia **(Dx) derecha** o **(Sx) izquierda** de la máquina o de sus componentes, se entiende, como en la figura, mirando la máquina por la parte trasera. Se indicarán las excepciones.

## PIESE DE SCHIMB

*Comandarea pieselor de schimb se va face prin intermediul concesionarilor din zonă și trebuie să fie întotdeauna însoțite de următoarele date:*

- **Tipul, modelul și numărul de matricolă al utilajului.** *Aceste date se găsesc pe plăcuța de identificare a fiecărui utilaj.*
- **Numărul de cod al piesei de schimb cerute, care se găsește în manual.**
- **Descrierea piesei de schimb și cantitatea cerută.**
- **Numărul desenului în care se găsește piesa.**
- **Mijloc de transport.** *În cazul în care acesta nu este specificat, Firma Constructoare poate avea un regim special, nu răspunde de eventualele întârzieri de expediere datorate unor cauze de forță majoră.*

*Cheltuielile de transport sunt suportate de destinatar. Marfa este transportată pe riscul celui care efectuează comanda, chiar dacă marfa este vândută în condiții franco-destinare.*

**NOTA:** *Termenul (Dx) Dreapta sau (Sx) Stânga a utilajului sau a părților acestuia, este privind utilajul din partea posterioară. Excepțiile vor fi indicate.*

<b><i>Nr. Tav.</i></b>	<b><i>Descrizione - Description</i></b>	<b><i>Pag.</i></b>
TAV. 010	Telaio	4
TAV. 020	Elemento operatore	6
TAV. 030	Doppio rullo posteriore MECCANICO	8
TAV. 040	Ruote di sostegno	10
TAV. 050	Kit luci	12

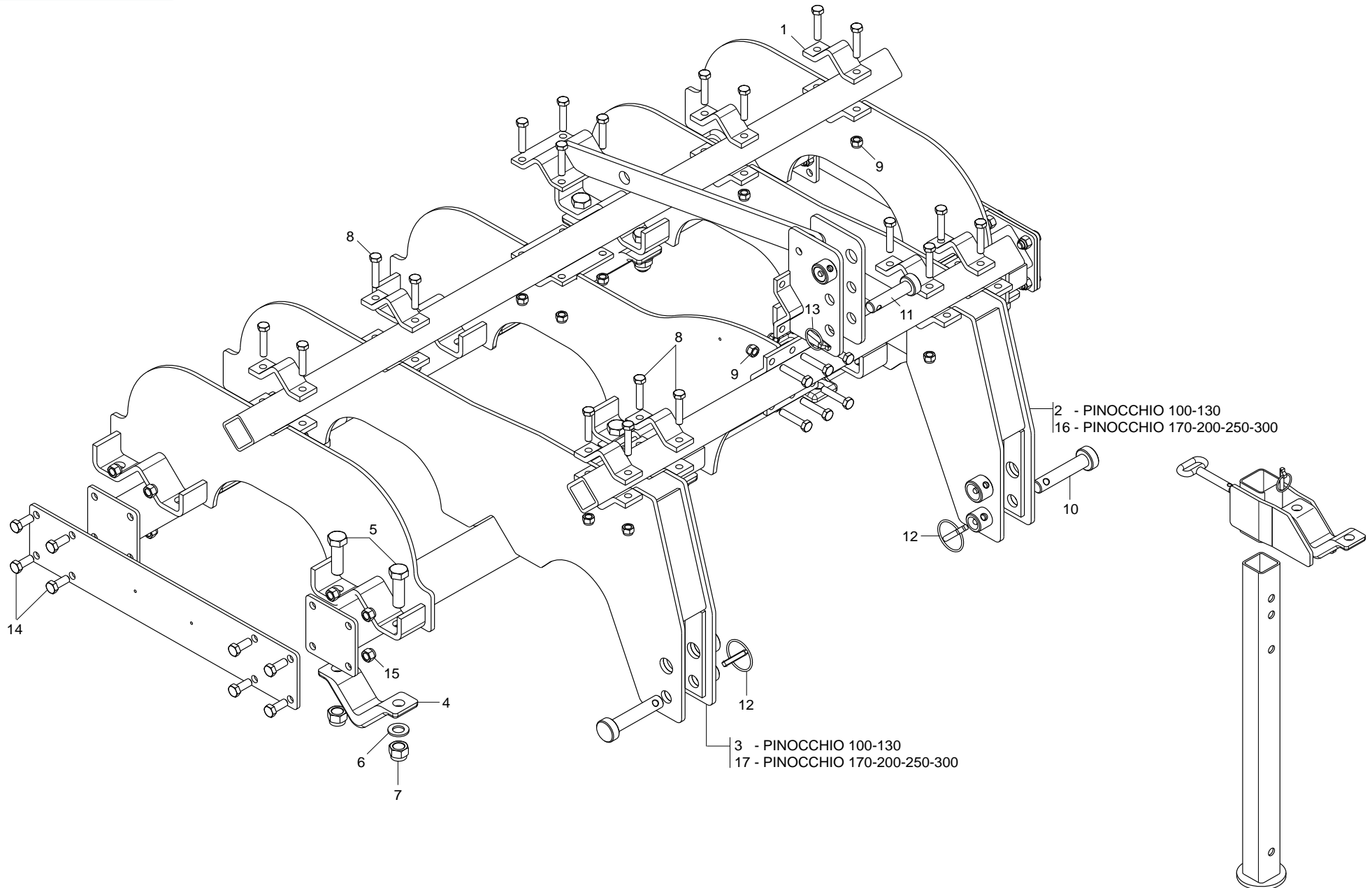

**TELAIO**

**TAV. 010**

Pos.	Cod.	Descrizione	Description	Description	Benennung	Descripcion	Descriere
1	R17812730	SCONTRIO	STRIKER	BRIDE	ANSCHLAG	ELEMENTO DE EMPALME	BRIDA
2	R17814310	ASS.SUPPORTO TELAIO SX	FRAME SUPPORT SX	SUPPORT CH-SSIS SX	RAHMENHALTERUNG SX	SOPORTE BASTIDOR SX	ANS.SUPPORT SASIU SX
3	R17814300	SUPPORTO TELAIO DX	FRAME SUPPORT DX	SUPPORT CH-SSIS DX	RAHMENHALTERUNG DX	SOPORTE BASTIDOR DX	ANS.SUPPORT SASIU DX
4	R17811170	SCONTRIO PER TUBO 100	STRIKER PLATE 100	BUTEE 100	ANSCHLAG 100	ELEMENTO DE EMPALME 100	BRIDA FIXARE TEAVA 100
5	F01020343	VITE M24X 3X 80 U5737 10.9 ZD	BOLT M24X 3X 80 U5737 10.9 ZB	VIS M24X 3X 80 U5737 10.9 ZB	SCHR.M24X 3X 80 U5737 10.9 ZB	TORN.M24X 3X 80 U5737 10.9 ZB	SUR. M24X 3X 80 U5737 10.9 ZB
6	G18701590	RONDELLA 25X35X2,5 ZB	WASHER 25x35x2,5 ZB	RONDELLE 25x35x2,5 ZB	UNTERLEGSCHIEBE 25x35x2,5	ARANDELA 25x35x2,5 ZB	SAIBA 25X35X2,5 ZB
7	F01230144	DADO M24X 3 D982 8 ZN	SELF-LOCKING NUT NORM.24 ZB	ECROU AUTOB.NORM.24 ZB	SELBSTSPERR. MUTTER NORM.24 ZB	TUERCA AUTOB. NORM.24 ZB	PIUL.M24X 3 D982 8 ZN
8	F01020205	VITE M14X2 X 65 5737 8.8 ZG	BOLTM 14X65	VIS M 14X65	SCHRAUBE M 14X65	TORNILLO M 14X65	VITE M14X2 X 65 5737 8.8 ZB
9	F01230073	PIULITA AUT.A M14X2 D982 8G Z	SELF LOCKING NUT M14X2	ECROU AUTOBL. M14X2	SELBSTSP.MUTT. M14X2	DADO AUTOBL. M14X2	PIULITA AUT.A M14X2 D982 8G Z
10	R17812910	SPINA D28,5 ZG	PIN D28,5 ZG	BROCHE D28,5 ZG	STIFT D28,5 ZG	CLAVIJAD28,5 ZG	STIFT D28,5 ZB
11	R17812900	SPINA D25,5 ZB	PIN D25,5 ZB	BROCHE D25,5 ZB	STIFT D25,5 ZB	CLAVIJAD25,5 ZB	STIFT D25,5 ZB
12	F02200584	SPINA SICUR. D. 12X70 ZN	GALVAN. SAFETY PIN D.12X70	GOUPILLE DE S+CURIT+ D.12X70 Z	SCHERSTIFT D.12X70 ZN	PASADOR DE SEGURIDAD D 12X70 Z	STIFT DE SIGURANTAD.12X70 ZN
13	F02200518	SPINA SCATTO D.10 ZG	SPLIT PIN D.10	GOUPILLE D.10	SPLINT D.10	RODETE D.10	SPLINT RESORT D.10 ZB
14	F01020566	VITE M16X 2X40 U5739 8.8 ZG	BOLTM16X2X40	VISM16X2X40	SCHRAUBE M16X2X40	TORNILLO M16X2X40	SURUB M16X2X40 5739 8.8 ZB
15	F01230085	DADO M16X 2 D982 8 ZB	NUT M16X 2 D982 8 ZB	ECROU M16X 2 D982 8 ZB	MUTT.M16X 2 D982 8 ZB	TUER.M16X 2 D982 8 ZB	PIUL.M16X 2 D982 8 ZB
16	R17812750	SUPPORTO TELAIO SX	FRAME SUPPORT SX	SUPPORT CH-SSIS SX	RAHMENHALTERUNG SX	SOPORTE BASTIDOR SX	ANS.SUPPORT SASIU SX
17	R17812740	SUPPORTO TELAIO DX	FRAME SUPPORT DX	SUPPORT CH-SSIS	RAHMENHALTERUNG DX	SOPORTE BASTIDOR DX	ANS.SUPPORT SASIU DX

TAV. 020

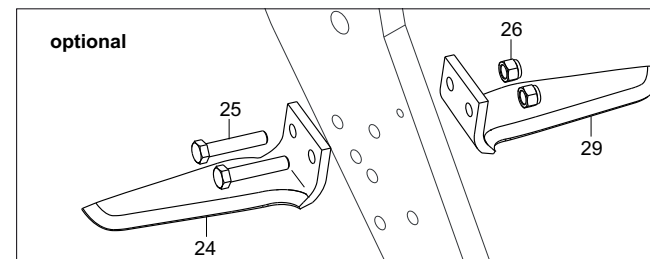
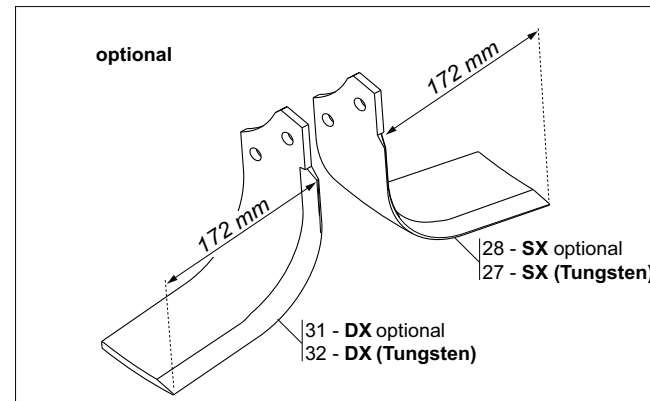
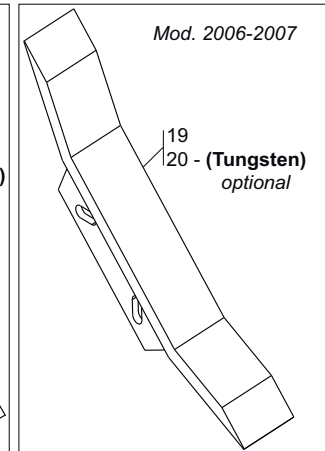
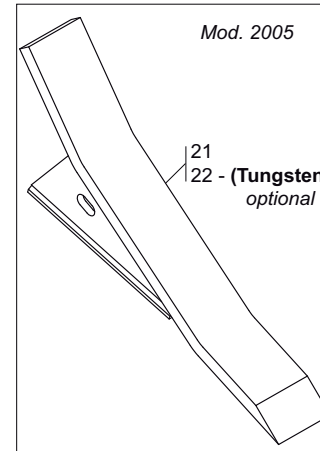
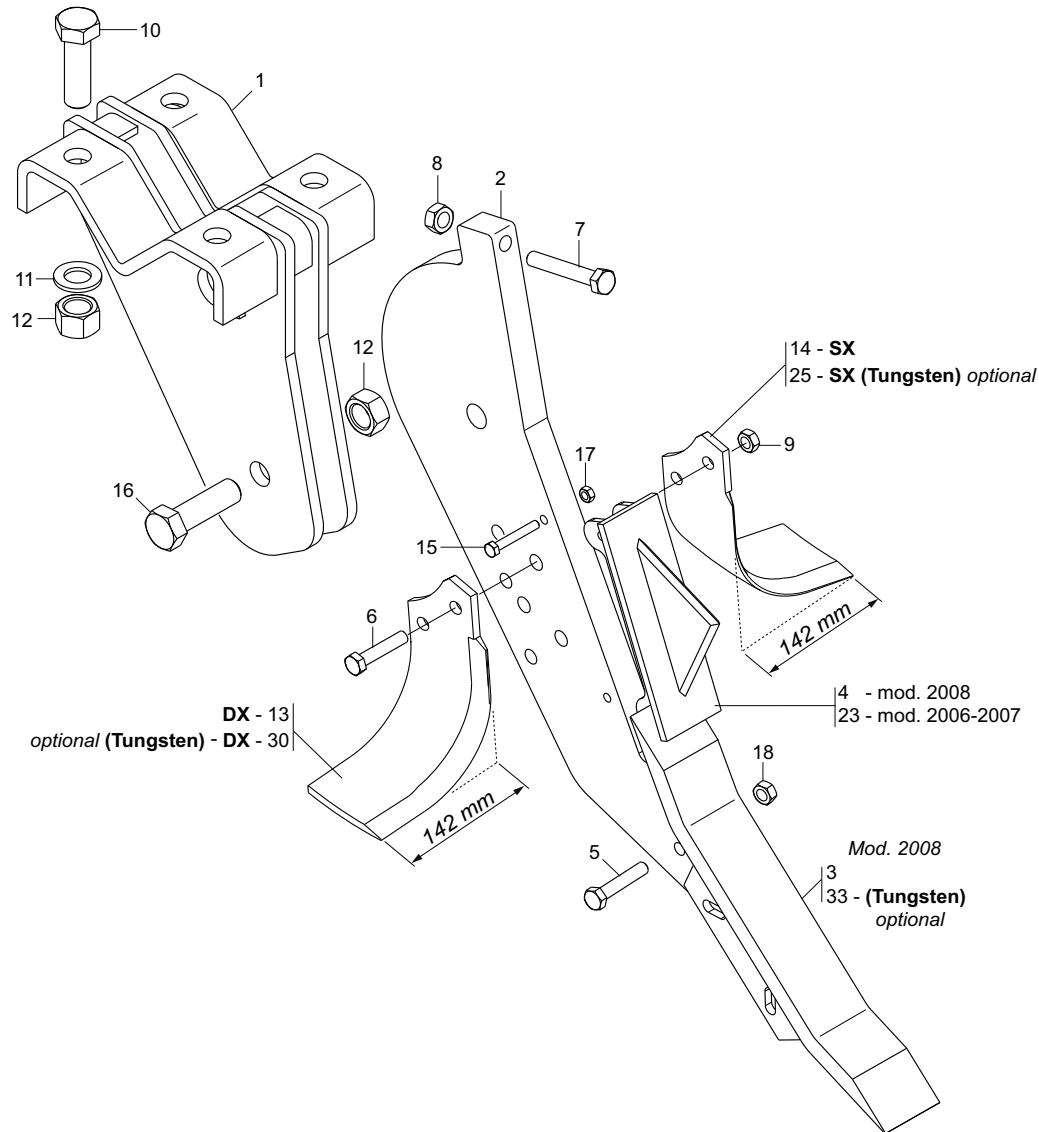

# ELEMENTO OPERATORE

TAV. 020

Pos.	Cod.	Descrizione	Description	Description	Benennung	Descrpcion	Descriere
1	R17820280	SUPPORTO	SUPPORT	SUPPORT	HALTERUNG	SOPORTE	ANS.SUPPORT SPRUIJN
2	R17820561	LAMA	BLADE	LAME	MESSER	CUCHILLA	LAMA PROPPIITOR
3	R17820681	ASSIEME DENTE	ANS. TOOTH	ANS. DENT	ZINKEN	DIENTE ATTILA	ANSAMBLU DINTE ATTILA
4	R17820411	ASSIEME LAMA SUPPORT	SUPPORT	LAME SUPPORT	MESSER	CUCHILLA SUPORTO	ANSAMBLU LAMA SUPORT
5	F01020162	VITE M12X1,75X65 U5737 8.8 ZG	BOLT M12X1,75X65 U5737 8.8 ZG	VIS M12X1,75X65 U5737 8.8 ZG	SCHRAUBE M12X1,75X65 U5737 8.8	TORNILLO M12X1,75X65 U5737 8.8	SUR. M12X1,75X65 U5737 8.8 ZB
6	F01020207	SURUB M14X 2X 70 U5737 8.8 ZB	BOLT M 14X70	VIS M 14X70	SCHRAUBE M 14X70	TORNILLO M 14X70	SURUB M14X 2X 70 U5737 8.8 ZB
7	F01020212	VITE M14X 2X 90 U5737 8.8 ZN	BOLT 14X90 5737 8.G GALVANIZ.	VIS 14X90 5737 8.G ZN	SCHRAUBE 14X90 5737 8.G ZN	TORNILLO 14X90 5737 8.G ZN	SURUB M14X 2X 90 U5737 8.8 ZB
8	F01260046	DADO FLANG.M14 D6923 8.8 ZN	NUT M14 D6923 8.8 ZB	ECROU M14 D6923 8.8 ZB	MUTTER M14 D6923 8.8 ZB	TUERCA M14 D6923 8.8 B	PIULITAFLANG.M14 D6923 8.8 ZB
9	F01230073	PIULITAAUT.AM14X2 D982 8G Z	SELF LOCKING NUT M14X2	ECROU AUTOBL. M14X2	SELBSTSPMUTT. M14X2	DADO AUTOBL. M14X2	PIULITAAUT.AM14X2 D982 8G Z
10	F01020343	VITE M24X 3X 80 U5737 10.9 ZD	BOLT M24X 3X 80 U5737 10.9 ZB	VIS M24X 3X 80 U5737 10.9 ZB	SCHR.M24X 3X 80 U5737 10.9 ZB	TORN.M24X 3X 80 U5737 10.9 ZB	SUR. M24X 3X 80 U5737 10.9 ZB
11	G18701590	RONDELLA 25X35X2,5 ZB	WASHER 25 x 35 x2,5 ZB	RONDELLE 25 x 35 x2,5 ZB	UNTERLEGSCHIEBE 25 x 35 x2,5	ARANDELA 25 x 35 x2,5 ZB	SAIBA 25X35X2,5 ZB
12	F01230144	DADO M24X 3 D982 8 ZN	SELF-LOCKING NUT NORM.24 ZB	ECROU AUTOB.NORM.24 ZB	SELBSTSPERR. MUTTER NORM.24 ZB	TUERCA AUTOB .NORM.24 ZB	PIUL.M24X 3 D982 8 ZN
13	M74100435	ZAPPA*AD ELICADESTRA SP.10	RIGHT C BLADES (THICKNESS 10)	LAME HELICE DRT	RECHTES BOGENMESSER	AZADA HELICE DERECHA	SAPA ELICOIDALADREAPTA
14	M74100436	ZAPPA*AD ELICASINISTRA SP.10	LEFT HELICOIDAL BLADE	LAME HELICE B-C-SC GCH	RECHTES BOGENMESSER	AZADA HELICE	SAPA ELICOIDALASTANGA
15	F01020077	VITE M 8X1,25X60 U5737 8.8 ZG	BOLT M 8X60	VIS M 8X60	SCHRAUBE M 8X60	TORNILLO M 8X60	SURUBURI M8X1,25X60 U5737
16	F01020349	VITE M24X 3X 90 U5737 8.8 ZN	BOLT M24X 3X 90 U5737 8.8 ZB	VIS M24X 3X 90 U5737 8.8 ZB	SCHR.M24X 3X 90 U5737 8.8 ZB	TORN.M24X 3X 90 U5737 8.8 ZB	SUR. M24X 3X 90 U5737 8.8 ZB
17	F01230034	DADO M 8X1,25 D982 8	SELF LOCKING NUT M8X1,25	ECROU AUTOBL. M8X1,25	SELBSTSP.MUTT. M8X1,25	DADO AUTOBL. M8X1,25	PIULITAAUT.M8X1,25 D982 8G ZB
18	F01230059	DADO M12X1,75 D982 8 ZB	NUT M12X1,75 D982 8 ZB	ECRO.M12X1,75 D982 8 ZB	MUTT.M12X1,75 D982 8 ZB	TUER.M12X1,75 D982 8 ZB	PIUL.M12X1,75 D982 8 ZB
19	R17820680	DENTE ATT/PIN RAPIDO REVERSIB	POINT ATT/PIN RAPIDO REVERSIB	EMBOUT GRIFFE	ZAHN KLAUESTUTZE	DIENTE PUNTAL GARRA	DINTE ATT-PIN Atasare Rap.Rev.
20	R17820730	DENTE ATT-PIN Tungs Zg.Rap.Rev	TOOTH ATT-PIN Tungs.QuickF Rev	DENTE ATT-PIN Tungs Zg Rap Rev	ZAHN KLAUESTUTZE	DIENTE PUNTAL GARRA	DINTE ATT-PIN Tungs At.Rap Rev
21	R17820340	DENTE ATT-PIN ZGANCIO RAP.REV.	TOOTH ATTILA PINOCCHIO Quick F	DENTE ATTILA PINOCCHIO	ZAHN KLAUESTUTZE	DIENTE PUNTAL GARRA	DINTE ATT-PIN AT.RAPID.REVERS
22	R17820640	DENTE ATT-PIN TG ZGAN.RAP+REV	TOOTH ATT-PIN Tungsten Quick F	DENTE ATT-PIN Tungsten	ZAHN KLAUESTUTZE Tungsten	DIENTE PUNTAL GARRA Tungsten	DINTE ATT-PIN TG AT. RAP+REV
23	R17820410	ASS.LAMA SUPPORTO	BLADE SUPPORT	LAME SUPPORT	MESSER SUPPORT	CUCHILLA SOPORTE	ANS.LAMA SUPORT
24	M27100210	COLTELLO DC/DS/DL DX 90X12	CLOCKWISE BLADE	COUTEAU DC-BR-CPR 12MM DRT	RECHTES MESSER	CUCHILLO DERECHO	CUTIT DREAPTA
25	F01020263	VITE 16X80 5737 8.G *	SCREW 16X80 5737 8.G	VIS 16X80 5737 8.G *	SCHRAUBE 16X80 5737 8.G	TORNILLO 16X80 5737 8.G	SURUB M16X 2X 80 U5737 8.8
26	F01230085	DADO M16X 2 D982 8 ZB	NUT M16X 2 D982 8 ZB	ECROU M16X 2 D982 8 ZB	MUTT.M16X 2 D982 8 ZB	TUER.M16X 2 D982 8 ZB	PIUL.M16X 2 D982 8 ZB
27	R17820890	ZAPPAAD ELICA SX P30 TUNGSTEN	LEFT HELICOIDAL BLADE P30 TG	LAME HELICE B-C-SC GCH P30 TG	LINKES BOGENMESSER SX P30 TG	AZADA HELICE IZQUIERDA P30 TG	SAPA ELICE SX P30 TUNGSTEN
28	R17820820	ZAPPA ELICA SINISTRA	RIGHT HELICOIDAL BLADE	LAME HELICE B-C-SC GCH	RECHTES BOGENMESSER	AZADA HELICE DERECHA	SAPASX
29	M27100209	COLTELLO DC/DS/DL SX 90X12	COUNTERCLOCKWISE BLADE	COUTEAU DC-BR-CPR 12MM GCH	LINKES MESSER	CUCHILLO IZQUIERDO	CUTIT STINGA
30	R17820860	ZAPPA ELICA DESTRA TUNGSTEN	RIGHT HELICOIDAL BLADE TUNGSTE	LAME HELICE B-C-SC DRT TUNGST	RECHTES BOGENMESSER TUNGSTEN	AZADA HELICE DERECHA TUNGSTEN	SAPAAD ELICE DX TUNGSTEN
31	R17820830	ZAPPA ELICA DESTRA P30	RIGHT HELICOIDAL BLADE P30	LAME HELICE B-C-SC DRT P30	RECHTES BOGENMESSER P30	AZADA HELICE DERECHA P30	SAPAAD ELICE DX P30
32	R17820880	ZAPPA ELICA DESTRA TG P30	RIGHT HELICOIDAL BLADE TG P30	LAME HELICE B-C-SC DRT TG P30	RECHTES BOGENMESSER TUNG P30	AZADA HELICE DERECHA TG P30	SAPAAD ELICE DX TUNGSTEN P30
33	R17820731	ASS. DENTE TG	ANS. TOOTH TG	ANS. DENT TG	ZINKEN TG	DIENTE TG ATTILA	ANSAMBLU DINTE TG

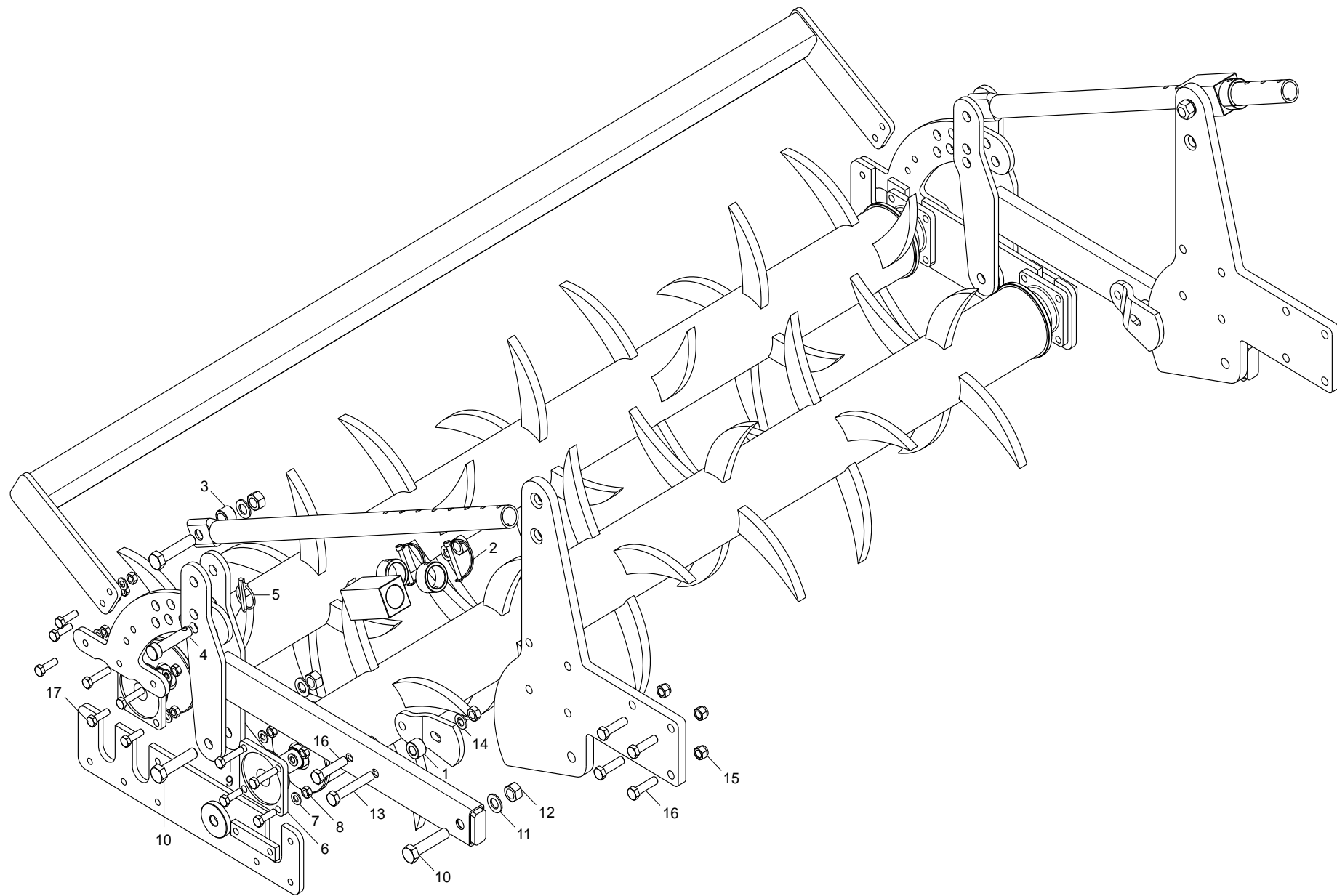



## DOPPIO RULLO POSTERIORE MECCANICO

TAV. 030

Pos.	Cod.	Descrizione	Description	Description	Benennung	Descripcion	Descriere
1	R17813230	BOCCOLA	BUSCHING	BOITE	BsCHSE	CASQUILLO	BUCSADISTANTATOARE
2	F02200562	SPINA SICUR. D. 8X70 ZN	SPLIT PIN D.8X70 ZB	GOUPILLE D.8X70 ZB	BOLZEN D.8X70 ZB	PERNO D.8X70 ZB	STIFT DE SIGURANTAD.8X70 ZB
3	R17812000	BOCCOLA 21,7X33,7X23 ZN	BUSHING 21,7X33,7X23 ZN	BOITE 21,7X33,7X23 ZN	BsCHSE 21,7X33,7X23 ZN	CASQUILLO 21,7X33,7X23 ZN	BUCSA 21,7X33,7X23 ZN
4	R17813310	PERNO	SCREW	VIS	SCHRAUBE	TORNILLO	BOLT DE POZITIE ZB
5	F02200507	SPINA SCATTO D. 9 B/83 ZN	SNAP PIN D 9 B/83	FICHE A DETENTE D 9 B/83	EINRASTSTIFT D 9 B/83	CLAVIJA DE MUELLE D 9 B/83	STIFT RESORT D 9 ZB B/83
6	F04100073	SUPPORTO CUSCINETTO FY35TF	BEARING SUPPORT	SUPPORT ROULEMENT	LAGERHALTERUNG	SOPORTE COJINETE	SUPORT RULMENT FY35TF
7	F01410076	RONDELLA D12 UNI 6592 ZN	PLANE WASHER D12 UNI 6592 ZN	RONDELLE D12 UNI 6592 ZN	SCHEIBE D12 UNI 6592 ZN	ARANDELA D12 UNI 6592 ZN	SAIBA PLANAD12 UNI 6592 ZB
8	F01230059	DADO M12X1,75 D982 8 ZB	NUT M12X1,75 D982 8 ZB	ECRO.M12X1,75 D982 8 ZB	MUTT.M12X1,75 D982 8 ZB	TUER.M12X1,75 D982 8 ZB	PIUL.M12X1,75 D982 8 ZB
9	F01020160	VITE M12X1,75X60 U5737 8.8 ZG	BOLT M12X1,75X60 U5737 8.8 ZG	VISM12X1,75X60 U5737 8.8 ZG	SCHRAUBE M12X1,75X60 U5737 8.8	TORNILLO M12X1,75X60 U5737 8.8	SURUB M12X1,75X 60.5737 8.8 ZB
10	F01020325	VITE M20X2,5X 90 U5737 10.9 ZD	BOLT 20X90 5737 10.9G GALVANI	VIS 20X90 5737 10.9G ZN	SCHRAUBE 20X90 5737 10.9G ZN	TORNILLO 20X90 5737 10.9G ZN	SURUB 20X90 5737 10.9 ZN
11	F01410124	ROS.M20 21X 37X 3 U6592 ZG	PLANE WASHER D20 UNI 6592 ZN	RONDELLE D20 UNI 6592 ZN	SCHEIBE D20 UNI 6592 ZN	ARANDELLA D20 UNI 6592 ZN	SAIBA PLANA D20 UNI 6592 ZB
12	F01230131	DADO M20X 2,5 D982 6 ZB	NUT M20X 2,5 D982 6 ZB	ECRO.M20X 2,5 D982 6 ZB	MUTT.M20X 2,5 D982 6 ZB	TUER.M20X 2,5 D982 6 ZB	PIUL.M20X 2,5 D982 6 ZB
13	F01020285	VITE M16X 2X100 U5737 8.8 ZN	BOLT 16X100 5737 8.8 GALVANIZ	VIS 16X100 5737 8.8 ZN	SCHRAUBE 16X100 5737 8.8 ZN	TORNILLO 16X100 5737 8.8 ZN	SURUB 16X100 5737 8.8 ZN
14	F01410100	ROS.M16 17X 30X 3 U6592 ZG	PLANE WASHER D16 UNI 6592 ZN	RONDELLE D16 UNI 6592 ZN	SCHEIBE D.16 UNI 6592 ZN	ARANDELA D16 UNI 6592 ZN	SAIBA M16 17X 30X 3 U6592 ZB
15	F01230085	DADO M16X 2 D982 8 ZB	NUT M16X 2 D982 8 ZB	ECROU M16X 2 D982 8 ZB	MUTT.M16X 2 D982 8 ZB	TUER.M16X 2 D982 8 ZB	PIUL.M16X 2 D982 8 ZB
16	F01030152	VITE M16X 2X70 U5933 8.8 ZN	BOLT M16X2X70 U5933 8.8 ZB	VIS M16X2X70 U5933 8.8 ZB	SCHRAUBE M16X2X70 U593308.8 ZN	TORNILLO M16X2X70 U5933 8.8 ZB	SUR.M16X 2X 70 U5933 8.8 ZB
17	F01020152	VITE M12X1,75X40 U5737 8.8 ZB	BOLT M12X1,75X 40 5737 8.8 ZB	VIS M12X1,75X 40 5737 8.8 ZB	SCHR.M12X1,75X 40 5737 8.8 ZB	TORN.M12X1,75X 40 5737 8.8 ZB	SUR. M12X1,75X 40 5737 8.8 ZB

TAV. 040

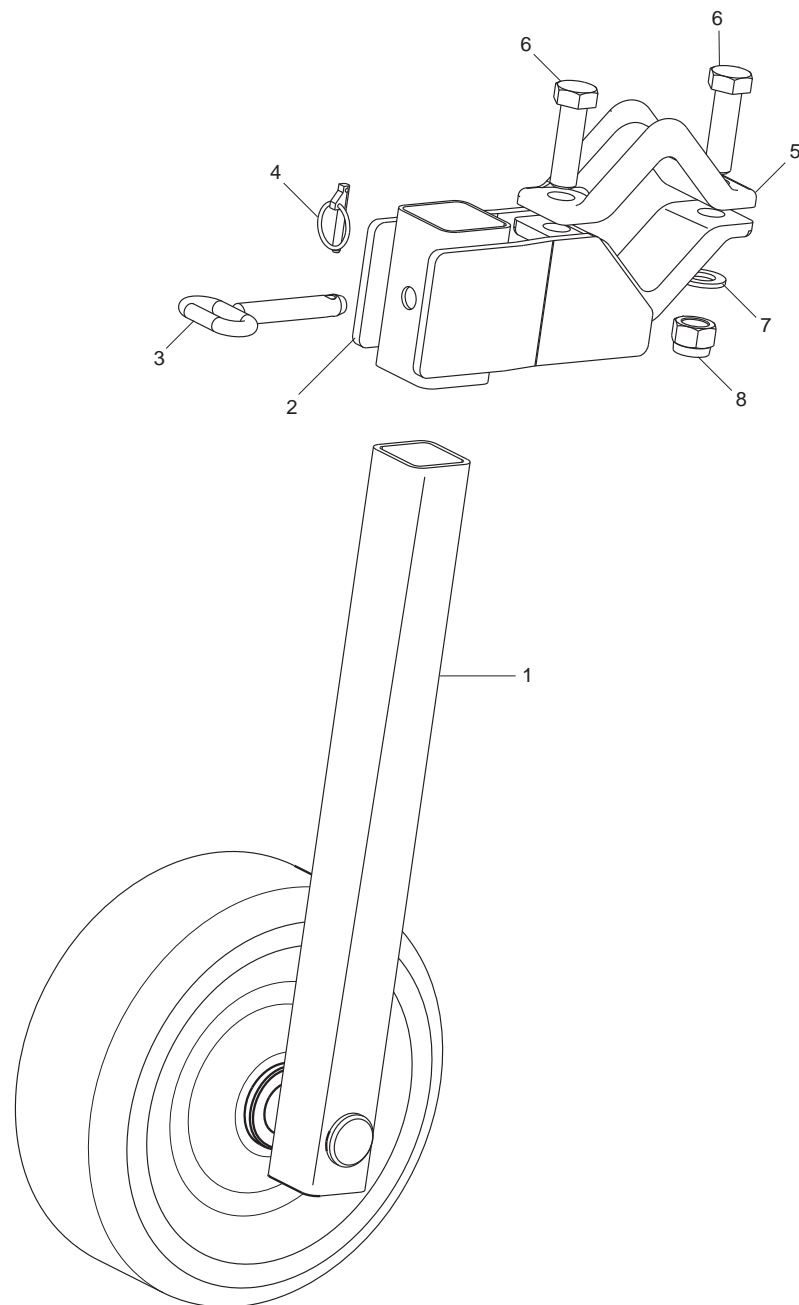

# RUOTE DI SOSTEGNO

TAV. 040

Pos.	Cod.	Descrizione	Description	Description	Benennung	Descripcion	Descriere
1	R18012160	RUOTA	WHEEL	ROUE	TIEFEN	RUEDA	ANSAMBLUROATA
2	R17815720	SUPPORTO SOSTEGNO	SUPPORT SEALING	SUPPORT ETANCHEITE	HALTERUNG DICHTUNGS	SOPORTE AISLADOR	ANS.SUPPORT SUSTINERE
3	R17810440	PERNO ZN	PIN ZN	PIVOT ZN	BOLZEN ZN	PERNO ZN	BOLT ZN
4	F02200507	SPINA SCATTO D. 9 B/83 ZN	SNAP PIND 9 B/83	FICHE A DETENTE D 9 B/83	EINRASTSTIFT D 9 B/83	CLAVIJA DE MUELLE D 9 B/83	STIFT RESORT D 9 ZB B/83
5	R17811170	SCONTRO PER TUBO 100	STRIKER PLATE 100	BUTEE 100	ANSCHLAG 100	ELEMENTO DE EMPALME 100	BRIDA FIXARE TEAVA 100
6	F01020343	VITE M24X 3X 80 U5737 10.9 ZB	BOLT M24X 3X 80 U5737 10.9 ZB	VIS M24X 3X 80 U5737 10.9 ZB	SCHR.M24X 3X 80 U5737 10.9 ZB	TORN.M24X 3X 80 U5737 10.9 ZB	SUR. M24X 3X 80 U5737 10.9 ZB
7	G18701590	RONDELLA 25X35X2,5 ZB	WASHER 25 x 35 x 2,5 ZB	RONDELLE 25 x 35 x 2,5 ZB	UNTERLEGSCHHEIBE 25 x 35 x 2,5	ARANDELA 25 x 35 x 2,5 ZB	SAIBA 25X35X2,5 ZB
8	F01230144	DADO M24X 3 D982 8 ZN	SELF-LOCKING NUT NORM.24 ZB	ECROU AUTOB.NORM.24 ZB	SELBSTSPERR. MUTTER NORM.24 ZB	TUERCA AUTOB. NORM.24 ZB	PIUL.M24X 3 D982 8 ZN

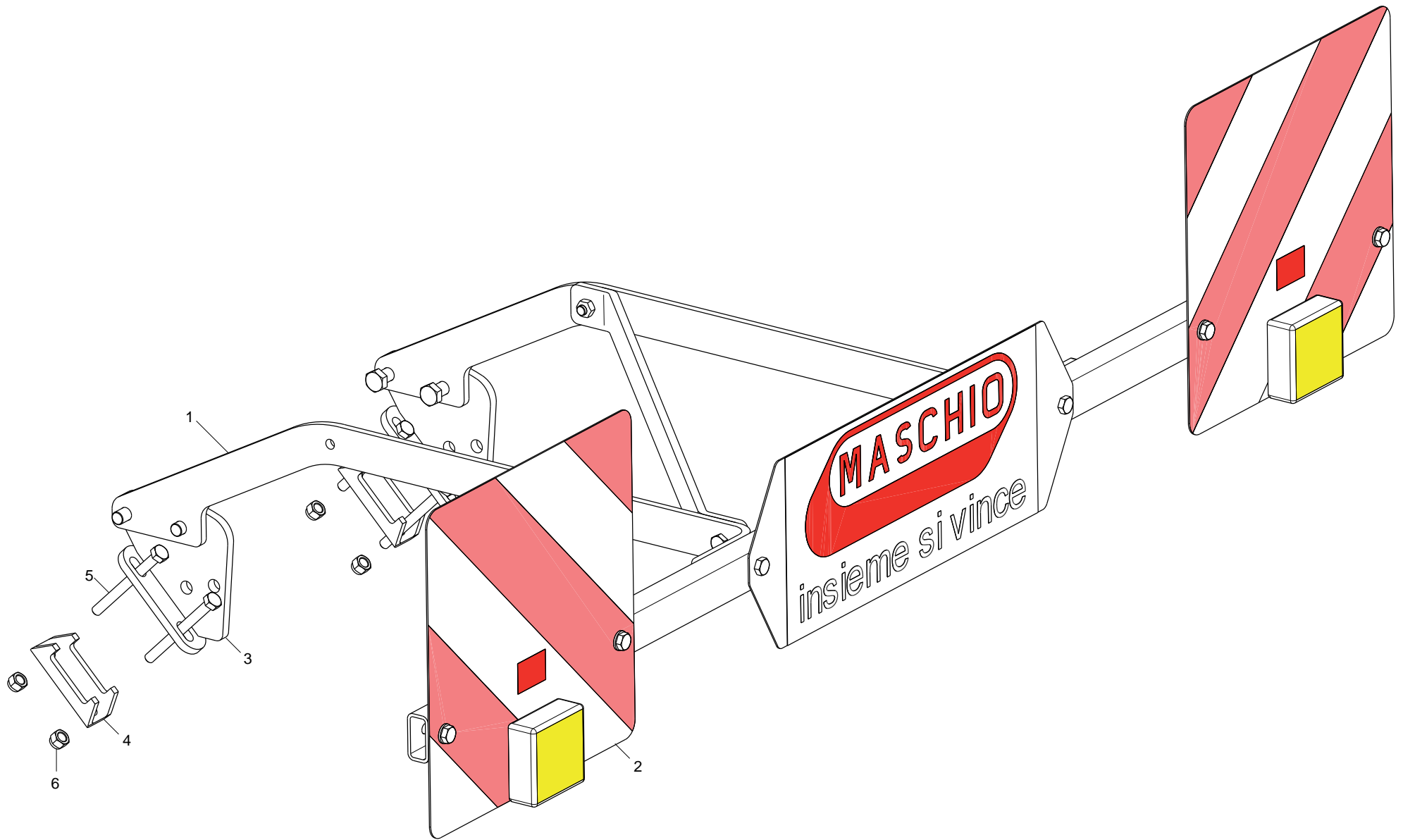

**KIT LUCI**

**TAV. 050**

Pos.	Cod.	Descrizione	Description	Description	Benennung	Descripcion	Descriere
1	M12400957	FANALE KIT LUCI	LAMP KIT LIGHTS	FEU KIT ECLAIRAGE	LAMPEN KIT LICHT	FAROL SET LUCES	FARURI PENTRU SET LUMINI
2	M12400956	KIT SUPPORTO BARRA LUCE	KIT SUPPORT	KIT SUPPORT	KIT HALTERUNG	KIT SOPORTE	KIT SUPORT BARA DE LUMINI
3	R17841000	ASSIEME ATTACCO	COUPLING	FIXATION	KUPPLUNG	CONEXIN	ANSAMBLU ATASARE
4	G16740160	SCONTRO A U SP.8 2F13 83	U-SHAPED STOP TEETH B343SP.8	BUTEE EN U SP.8 2F13 83	U-ANSCHLAG SP.8 2F13 83	DIENTE DE PARADAA U ESP.8	BRIDA U SP.8 2F13 83
5	F01020174	VITE M12X1,75X1205737 8.8 ZN	BOLT 12X1205737 8.8 GALVANIZ.	VIS 12X1205737 8.8 ZN	SCHRAUBE 12X1205737 8.8 ZN	TORNILLO 12X1205737 8.8 ZN	SUR. M12X1,75X1205737 8.8 ZB
6	F01230059	DADO M12X1,75 D982 8 ZB	NUT M12X1,75 D982 8 ZB	ECRO.M12X1,75 D982 8 ZB	MUTT.M12X1,75 D982 8 ZB	TUER.M12X1,75 D982 8 ZB	PIUL.M12X1,75 D982 8 ZB

**USATE SEMPRE RICAMBI ORIGINALI  
ALWAYS USE ORIGINAL SPARE PARTS  
IMMER DIE ORIGINAL-ERSATZTEILE VERWENDEN  
EMPLOYEZ TOUJOURS LES PIECES DE RECHANGE ORIGINALES  
UTILIZAR SIEMPRE REPUESTOS ORIGINALES  
UTILIZAȚI ÎNTOTDEAUNA PIESE DE SCHIMB ORIGINALE**

**MASCHIO GASPARDO**

**Serviciu Asistentă Tehnică +40 752 30 70 43  
Piese de schimb +40 742 30 70 52**



**MASCHIO GASPARDO**

**MASCHIO GASPARDO SpA**

**Sede legale e stabilimento produttivo**

Via Marcello, 73 - 35011 Campodarsego (Padova) - Italy

Tel. +39 049 9289810

Fax +39 049 9289900

Email: [info@maschio.com](mailto:info@maschio.com)

[www.maschionet.com](http://www.maschionet.com)

**MASCHIO DEUTSCHLAND GMBH**

Äußere Nürnberger Straße 5

D - 91177 Thalmässing ng

Deutschland

Tel. +49 (0) 9173 79000

Fax +49 (0) 9173 790079

**MASCHIO FRANCE Sarl**

1, Rue de Mérignan ZA

F - 45240 La Ferte St. Aubin

France

Tel. +33 (0) 2.38.64.12.12

Fax +33 (0) 2.38.64.66.79

**MASCHIO IBERICA S.L.**

Calle Cabernet, 10

Poligono Industrial Clot de Moja

Olerdola - 08734 Barcelona

Tel. +34 93.81.99.058

Fax +34 93.81.99.059

**MASCHIO-GASPARDO USA Inc**

120 North Scott Park Road

Eldridge, IA 52748 - USA

Ph. +1 563 2859937

Fax +1 563 2859938

e-mail: [info@maschio.us](mailto:info@maschio.us)

**MASCHIO GASPARDO SpA**

**Stabilimento produttivo**

Via Mussons, 7 - 33075

Morsano al Tagliamento (PN) - Italy

Tel. +39 0434 695410

Fax +39 0434 695425

Email: [info@gaspardo.it](mailto:info@gaspardo.it)

**ООО МАСКИО-ГАСПАРДО РУССИЯ**

404126, Россия, Волгоградская область,

г.Волжский, ул.Пушкина, 117\*б\*.

Тел.: +78443525065

факс: +78443525064

e-mail: [info@maschio.ru](mailto:info@maschio.ru)

<http://www.maschionet.com>

**MASCHIO GASPARDO ROMANIA SRL**

Strada Înfrățirii, Nr. 155

315100 Chișineu - Criș

Tel. +40 257 30 70 30

Fax +40 257 30 70 40

e-mail: [info@maschio.com](mailto:info@maschio.com)

<http://www.maschio.com>

**MASCHIO MIDDLE EAST**

P.O. Box 922388

Amman, 11192 Jordan

Tel. 962 605511384

Fax 962 6 5538398

e-mail: [tahaeng@nets.com.jo](mailto:tahaeng@nets.com.jo)

**GASPARDO-MASCHIO TURCHIA**

**MASCHIO-GASPARDO CANADA Inc**

**MASCHIO-GASPARDO CINA**

**MASCHIO-GASPARDO POLAND**

**MASCHIO-GASPARDO UCRAINA**

**GASPARDO BIELORUSSIA**

**MASCHIO-GASPARDO KOREA**