

MASCHIO GASPARDO

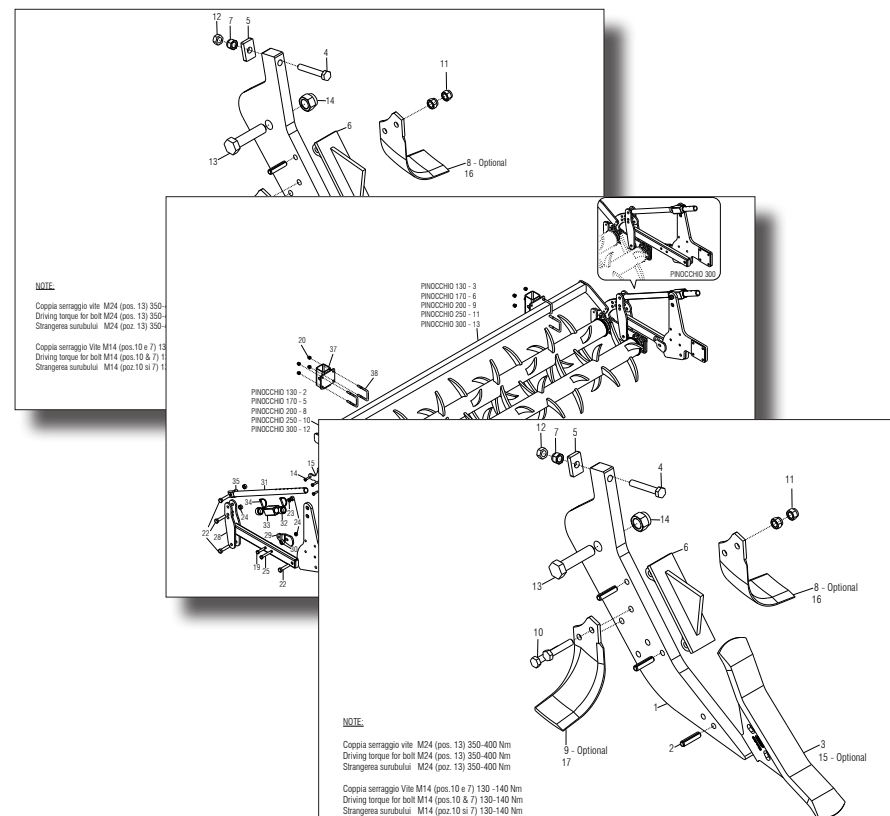

PINOCCHIO

Cod: F07011325 12 / 2015

- *) Valido per Paesi UE
- *) Valid for EU member countries
- *) Gilt für EU-Mitgliedsländer
- *) Valable dans le Pays UE
- *) Válido para Países UE
- *) Valabil pentru țările UE

- IT** PARTI DI RICAMBIO
- EN** SPARE PARTS
- DE** ERSATZTEILE
- FR** PIÈCES DÉTACHÉES
- ES** PIEZAS DE REPUESTO
- RO** PIESE DE SCHIMB

PARTI DI RICAMBIO

Le ordinazioni delle parti di ricambio vanno fatte presso i nostri concessionari di zona e devono essere sempre corredate dalle seguenti indicazioni:

- **Tipo, modello e numero di matricola dell'attrezzatura.** Tali dati sono stampigliati nell'apposita targhetta di cui è dotata ogni attrezzatura.
- **Numero di codice della parte richiesta** rilevabile dal catalogo ricambi.
- **Descrizione del particolare e quantità richiesta.**
- **Numero della tavola.**
- **Mezzo di trasporto.** Nel caso questa voce non sia specificata, la Ditta Costruttrice, pur dedicando a questo servizio una particolare cura, non risponde di eventuali ritardi di spedizione dovuti a cause di forza maggiore.

Le spese di trasporto si intendono sempre a carico del destinatario. La merce viaggia a rischio e pericolo del committente anche se venduta franco destino.

NOTA: Il termine **(Dx) Destro** o **(Sx) Sinistro** della macchina o di parti di essa, è inteso guardando la macchina dalla parte posteriore. Le eccezioni saranno indicate.

SPARE PARTS

Orders must be transmitted through our area dealers and should always include the following indications:

- **Type, model and serial number of the machine.** These data are punched on the data plate with which every implement is equipped.
- **Code number of the required spare part.** This will be found in the spare parts catalogue.
- **Description of the part and required quantity.**
- **Table number.**
- **Means of dispatch.** If this item is not indicated, the Manufacturer, while dedicating particular care to this service, shall not be held responsible for delays in delivery caused by cases of force majeure.

Transport expenses shall always be at the consignee's charge. The goods travel at the purchaser's risk and peril even when sold ex destination.

NOTE: The symbols **(Dx) right** and **(Sx) left**, concerning the machine or single parts of it, are referred, as in the figure, to a rear view of them. Exceptions will be indicated.

ERSATZTEILE

Die Bestellungen müssen bei unseren Gebietshändler angegeben werden. Bei der Bestellung sind stets die folgenden Angaben zu machen:

- **Typ, Modell und Serien-Nummer des Geräts.** Diese Daten stehen auf dem Typenschild, mit dem jedes Gerät versehen ist.
- **Artikel Nr. der erforderlichen Ersatzteile.** Diese stehen im Ersatzteil-Katalog.
- **Beschreibung des Ersatzteils und die erforderliche Stückzahl.**
- **Tafelnummer.**
- **Versandmittel.** Wenn dieser Punkt nicht spezifiziert wird, haftet die Herstellerfirma nicht für etwaigen Lieferverzug aufgrund höherer Gewalt, auch wenn er diesen Service besonders aufmerksam abwickelt.

Die Frachtkosten gehen dagegen immer zu Lasten des Empfängers. Die Ware reist auf Gefahr und Risiko des Auftraggebers, auch wenn frei Haus Verkauft vereinbart worden ist.

N.B.: Die Merkzeichen **(Dx) rechts** und **(Sx) links** betreffen eine rückwärtige Aussicht der Maschine oder Teile von ihr (siehe Bild). Ausnahmen werden gezeigt.

PIÈCES DÉTACHÉES

Les ordres doivent être effectués auprès de nos concessionnaires de zone en précisant les indications suivantes:

- **Type, modèle et numéro de série de la machine.** Ces données sont gravées sur la plaque d'identification de chaque outil.
- **Numéro de code de la pièce détachée** indiqué sur le catalogue des pièces détachées.
- **Description de la pièce et quantité requise.**
- **Numéro de plan.**
- **Moyen d'expédition.** Si cette rubrique n'est pas indiquée, le Constructeur, bien que soucieux de ce service, ne répond pas des retards d'expédition pour des causes de force majeure. Les frais de transport sont toujours à la charge du destinataire. La marchandise voyage aux risques et périls de l'acheteur même si vendue franco de port.

N.B.: Les références **(Dx) droit** et **(Sx) gauche** de la machine ou des parties de la même, est entendue, comme de la figure, en regardant la machine de derrière dans le sens de marche.

REPUESTOS

Los pedidos han de efectuarse en nuestros concesionarios de zona y deben incluir siempre las siguientes indicaciones:

- **Tipo, modelo y número de matrícula del equipo.** Dichos datos están impresos en la relativa placa presente en el equipo.
- **Número de código de la parte requerida** presente en el catálogo repuestos.
- **Descripción de la pieza y cantidad requerida.**
- **Numero de ilustración.**
- **Medio de transporte.** En caso que este ítem no esté especificado, el Fabricante, aún prestando la debidas consideraciones para este aspecto, no responde por eventuales retardos de envío debidos a causas de fuerza mayor.

Los gastos de transporte se consideran siempre a cargo del destinatario. La mercadería viaja bajo riesgo y peligro del comprador, incluso cuando se vende franco destino.

N.B.: La referencia **(Dx) derecha** o **(Sx) izquierda** de la máquina o de sus componentes, se entiende, como en la figura, mirando la máquina por la parte trasera. Se indicarán las excepciones.

PIESE DE SCHIMB

Comandarea pieselor de schimb se va face prin intermediul concesionarilor din zonă și trebuie să fie întotdeauna însoțite de următoarele date:

- **Tipul, modelul și numărul de matricolă al utilajului.** Aceste date se găsesc pe plăcuța de identificare a fiecărui utilaj.
- **Numărul de cod al piesei de schimb cerute,** care se găsește în manual.
- **Descrierea piesei de schimb și cantitatea cerută.**
- **Numărul desenului în care se găsește piesa.**
- **Mijloc de transport.** În cazul în care acesta nu este specificat, Firma Constructoare poate avea un regim special, nu răspunde de eventualele întârzieri de expediere datorate unor cauze de forță majoră.

Cheltuielile de transport sunt suportate de destinatar. Marfa este transportată pe riscul celui care efectuează comanda, chiar dacă marfa este vândută în condiții franco-destinatare.

NOTĂ: Termenul **(Dx) Dreapta** sau **(Sx) Stânga** a utilajului sau a părților acestuia, este privind utilajul din partea posterioară. Excepțiile vor fi indicate.

Nr. Tav.	Descrizione	Pag.	Nr. Tav.	Description	Pag.
TAV. 010	Telaio	4	TAV. 010	Cadre	4
TAV. 020	Elemento operatore	6	TAV. 020	Élément opérateur	6
TAV. 030	Doppio rullo posteriore meccanico	8	TAV. 030	Double rouleau postérieur mécanique	8
TAV. 040	Ruota di profondità	10	TAV. 040	Roue de profondeur	10
TAV. 050	Kit staffe luci	12	TAV. 050	Kit support d'éclairage	12

Nr. Tav.	Description	Pag.	Nr. Tav.	Descripción	Pag.
TAV. 010	Frame	4	TAV. 010	Bastidor	4
TAV. 020	Operator element	6	TAV. 020	Elemento operador	6
TAV. 030	Mechanic double rear roller	8	TAV. 030	Doble rodillo posterior mecánico	8
TAV. 040	Depth wheel	10	TAV. 040	Rueda de profundidad	10
TAV. 050	Lights support kit	12	TAV. 050	Kit soporte de iluminación	12

Nr. Tav.	Beschreibung	Pag.	Nr. Tav.	Descriere	Pag.
TAV. 010	Rahmen	4	TAV. 010	Cadru	4
TAV. 020	Betreiber elemente	6	TAV. 020	Element operator	6
TAV. 030	Mechanisch doppelte hintere walze	8	TAV. 030	Rulou dublu posterior mecanic	8
TAV. 040	Tiefenrad	10	TAV. 040	Roată de adâncime	10
TAV. 050	Lichter halter kit	12	TAV. 050	Kit suport lumini	12

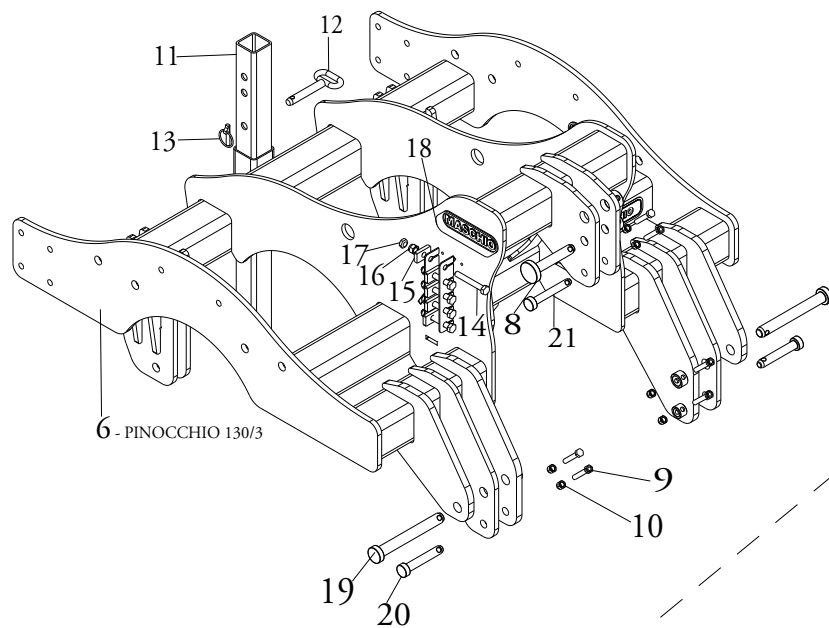

- 1 - PINOCCHIO 170/5
- 2 - PINOCCHIO 200/5
- 3 - PINOCCHIO 250/5
- 4 - PINOCCHIO 250/7
- 5 - PINOCCHIO 300/7

- 9 - Pin
- 10 - Pin

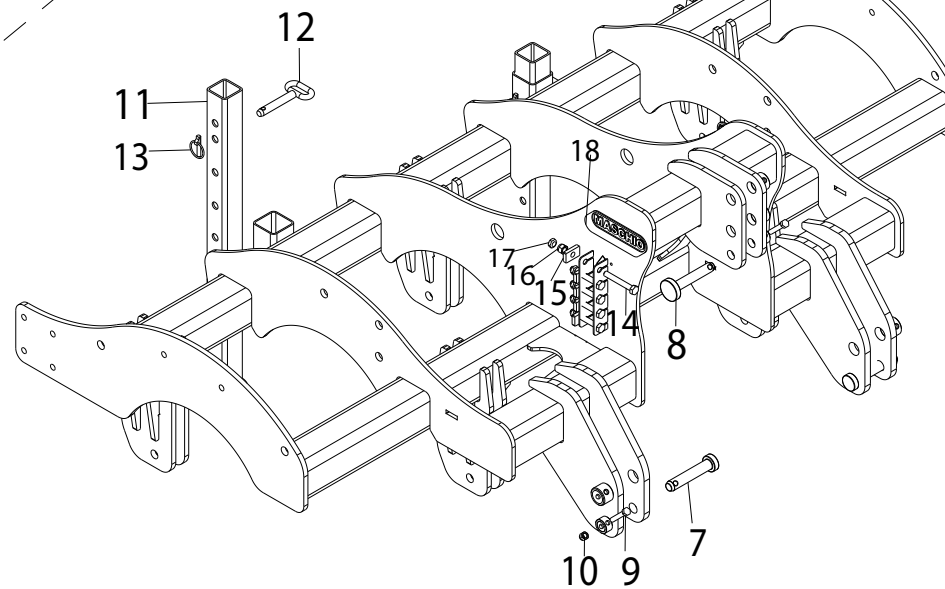

TELAIO / FRAME / RAHMEN / CADRE / BASTIDOR / CADRU

Pos.	Cod.	Descrizione	Description	Description	Benennung	Descripcion	Descriere
1	R17615052	TELAIO PINOCCHIO 130/3A CSS	FRAME PINOCCHIO 130/3A CSS	CHASSIS PINOCCHIO 130/3A CSS	RAHMEN PINOCCHIO 130/3A CSS	BASTIDOR PINOCCHIO 130/3A CSS	CADRU PINOCCHIO 130/3A CSS
2	R17615041	TELAIO PINOCCHIO 170/5A CSS	FRAME PINOCCHIO 170/5A CSS	CHASSIS PINOCCHIO 170/5A CSS	RAHMEN PINOCCHIO 170/5A CSS	BASTIDOR PINOCCHIO 170/5A CSS	CADRU PINOCCHIO 170/5A CSS
3	R17615031	TELAIO PINOCCHIO 200/5A CSS	FRAME PINOCCHIO 200/5A CSS	CHASSIS PINOCCHIO 200/5A CSS	RAHMEN PINOCCHIO 200/5A CSS	BASTIDOR PINOCCHIO 200/5A CSS	CADRU PINOCCHIO 200/5A CSS
4	R17615011	TELAIO PINOCCHIO 250/5A CSS	FRAME PINOCCHIO 250/5A CSS	CHASSIS PINOCCHIO 250/5A CSS	RAHMEN PINOCCHIO 250/5A CSS	BASTIDOR PINOCCHIO 250/5A CSS	CADRU PINOCCHIO 250/5A CSS
5	R17615021	TELAIO PINOCCHIO 250/7A CSS	FRAME PINOCCHIO 250/7A CSS	CHASSIS PINOCCHIO 250/7A CSS	RAHMEN PINOCCHIO 250/7A CSS	BASTIDOR PINOCCHIO 250/7A CSS	CADRU PINOCCHIO 250/7A CSS
6	R17614701	TELAIO PINOCCHIO 300/7A CSS	FRAME PINOCCHIO 300/7A CSS	CHASSIS PINOCCHIO 300/7A CSS	RAHMEN PINOCCHIO 300/7A CSS	BASTIDOR PINOCCHIO 300/7A CSS	CADRU PINOCCHIO 300/7A CSS
7	F20100137	PERNO D28 L124 C43 ZN	PIN D28 L124 C43 ZN	BOULON D28 L124 C43 ZN	BOLZEN D28 L124 C43 ZN	PERNO D28 L124 C43 ZN	BOLT D28 L124 C43 ZN
8	F20100133	PERNO D25 L122 C43 ZN	PIN D25 L122 C43 ZN	BOULON D25 L122 C43 ZN	BOLZEN D25 L122 C43 ZN	PERNO D25 L122 C43 ZN	BOLT D25 L122 C43 ZN
9	F01020118	VITE M10X1,5X60 U5737 8.8ZN	SCR. M10X1,5X60 U5737 8.8ZN	VIS 10X60 5737 8.G ZN	SCHRAUBE 10X60 5737 8.G ZN	TORNILLO 10X60 5737 8.G ZN	SURUB M10X 1,5X60 U5737 8.8 ZN
10	F01230045	DADO M10X1,5 D982 6ZN	NUT M10X1,5 D982 6ZN	ECROU AUTO-FREINES M10X1,5D982	SICHERUNGSMUTT.M10X1,5 D982 ZN	TUERCA DE SEGUR.M10X1,5 D982ZN	PIUL. M10X 1,5 D982 6 ZN
11	R17810380	PUNTELLO	PROP	ETRESILLON	STUTZE	PUNTAL	PICIOR
12	R17810441	PERNO D20 L110 ZN	BOLT D20 L110 ZN	BOULON D20 L110 ZN	BOLZEN D20 L110 ZN	PERNO D20 L110 ZN	BOLT D20 L110 ZN
13	F02200507	SPINA A SCATTO D9 B/83 ZN	SNAP PIN D9 B/83 ZN	FICHE A DETENTE D9 B/83 ZN	EINRASTSTIFT D9 B/83 ZN	CLAVIJA DE MUELLE D9 B/83 ZN	STIFT RESORT D9 B/83 ZN
14	F01020214	VITE M14X2X100 U5737 8.8ZN	SCREW M14X2X100 U5737 8.8ZN	VIS M14X2X100 U5737 8.8ZN	SCHRAU. M14X2X100 U5737 8.8ZN	TORN. M14X2X100 U5737 8.8ZN	SURUB M14X2X100 U5737 8.8ZN
15	R17622341	PIASTRA ANTISFONDAMENTO	DAMAGEPROOF PLATE	PLAQUE INCASSABLE	SPLITTERFREI PLATTE	PLACA INASTILLABLE	PLACA ANTIRUPERE
16	F01260046	DADO M14 D6923 8ZN	NUT M14 D6923 8ZN	ECROU BRIDE M14 D6923 8 ZN	MUTTER M14 D6923 8 ZN	TUERCA FL. M14 D6923 8 ZN	PIULITA FLANG.M14 D6923 8 ZN
17	F01200306	DADO M14X2 U5588 6.8ZN	NUT M14X2 U5588 6.8ZN	ECROU M14X2	MUTTER M14X2	DADO M14X2	PIULITA M14X2 5588 6S ZN
18	M36200360	MARCHIO MASCHIO 245X85 STAMP	MASCHIO BRAND	MARQUE MASCHIO	MASCHIO ZEICHEN	MARCA MASCHIO	MARCA MASCHIO 245X85 STAMP
19	F20100172	PERNO D28 L214 C43 ZN	PIN D28 L214 C43 ZN	GOUJON D28 L214 C43 ZN	BOLZEN D28 L214 C43 ZN	PERNO D28 L214 C43 ZN	BOLT D28 L214 C43 ZN
20	F20100047	PERNO D22 L108 C43 ZN	BOLT D22 L108 C43 ZN	GOUJON SUPPORT	BOLZEN	PERNO SOPORTE	BOLT D22 L108 C43 ZN
21	F20100173	PERNO D19 L120 C43 ZN	PIN D19 L120 C43 ZN	GOUJON D19 L120 C43 ZN	BOLZEN D19 L120 C43 ZN	PERNO D19 L120 C43 ZN	BOLT D19 L120 C43 ZN
22	F02250033	RIVETTO PLAST. P 1506 PER C	PLASTIC RIVET P 1506 PER C	RIVET PLAST. P1506 PER C	REISSNIETE P1506 PER C	REMACHE DESGAR. P1506 PER C	NIT PLASTIC 3.2X 6 P 1056/C

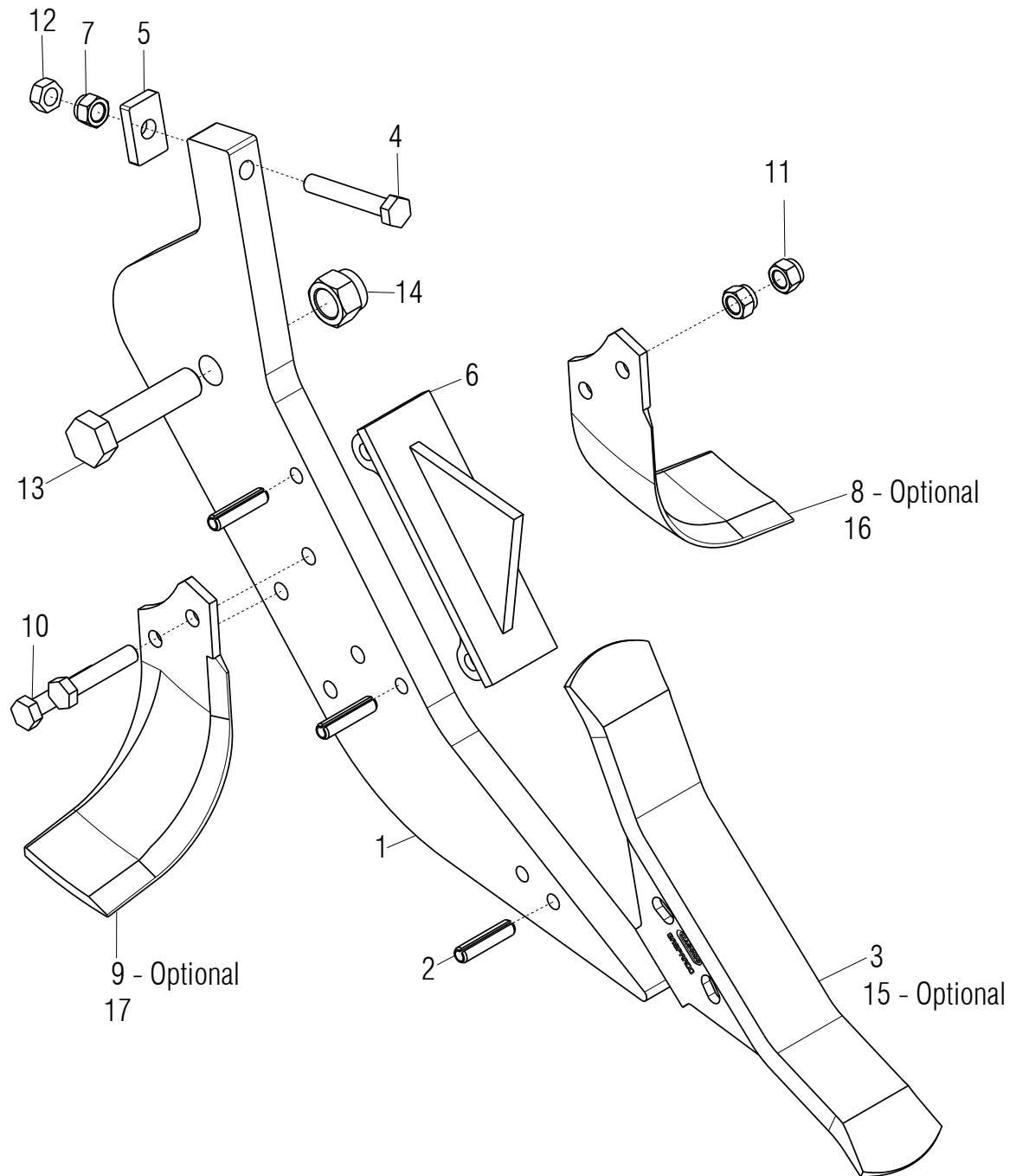

NOTE:

Coppia serraggio vite M24 (pos. 13) 350-400 Nm
 Driving torque for bolt M24 (pos. 13) 350-400 Nm
 Strangerea surubului M24 (poz. 13) 350-400 Nm

Coppia serraggio Vite M14 (pos.10 e 7) 130 -140 Nm
 Driving torque for bolt M14 (pos.10 & 7) 130-140 Nm
 Strangerea surubului M14 (poz.10 si 7) 130-140 Nm

**ELEMENTO OPERATORE / OPERATOR ELEMENT / BETREIBER ELEMENTE /
ELEMENT OPERATEUR / ELEMENTO OPERADOR/ ELEMENT OPERATOR**

TAV. 020

Pos.	Cod.	Descrizione	Description	Description	Benennung	Descripcion	Descriere
1	R17622220	ANCORA ATTILA CSS / PIN. CSS	TINE ATTILA CSS / PIN. CSS	EMBOUT ATTILA CSS / PIN. CSS	SPITZE ATTILA CSS / PIN. CSS	PUNTAL ATTILA CSS / PIN. CSS	ANCORA ATTILA CSS / PIN. CSS
2	F02100190	SPINA E.P. 13X50 U28752 C70 BR	ELASTIC PIN 13X50	GOUJON ELASTIQUE 13X50	SPANNHUELSE 13X50	ESPINA EL. 13X50	STIFT E.P. 13X50
3	R17220370	DENTE ATTILA / PINOCCHIO	TOOTH ATTILA / PINOCCHIO	DENT ATTILA / PINOCCHIO	ZAHN ATTILA / PINOCCHIO	DIENTE ATTILA / PINOCCHIO	DINTE ATTILA / PINOCCHIO
4	F01020214	VITE M14X2X100 U5737 8.8ZN	SCREW M14X2X100 U5737 8.8ZN	VIS M14X2X100 U5737 8.8ZN	SCHRAU. M14X2X100 U5737 8.8ZN	TORN. M14X2X100 U5737 8.8ZN	SURUB M14X2X100 U5737 8.8ZN
5	R17622341	PIASTRA ANTISFONDAMENTO	DAMAGEPROOF PLATE	PLAQUE INCASSABLE	SPLITTERFREI PLATTE	PLACA INASTILLABLE	PLACA ANTIRUPERE
6	R17820413	ROMPIZOLLA ATTILA/PINOCCHIO	CLOD BREAKER ATTILA/PINOCCHIO	BRISE-MOTTES ATTILA/PIN.	SCHOLLENBRECHER ATTILA/PIN.	DESTERRONADOR ATTILA/PINOCCHIO	SPARGATOR BRAZDA ATTILA/PIN.
7	F01260046	DADO M14 D6923 8ZN	NUT M14 D6923 8ZN	ECROU BRIDE M14 D6923 8 ZN	MUTTER M14 D6923 8 ZN	TUERCA FL. M14 D6923 8 ZN	PIULITA FLANG.M14 D6923 8 ZN
8	M74100436	ZAPPA AD ELICA SX 10MM	HELICOIDAL BLADE 10 MM LEFT	LAME HELICE GAUCHE 10MM	LINK BOGENMESSER 10MM	AZADA HELICE IZQUIERDA 10MM	SAPA ELICOIDALA SX 10MM
9	M74100435	ZAPPA AD ELICA DX 10MM	HELICOIDAL BLADE 10 MM RIGHT	LAME HELICE DROIT 10MM	RECHT BOGENMESSER 10MM	AZADA HELICE DERECHA 10MM	SAPA ELICOIDALA DX 10MM
10	F01020207	VITE M14X2X70 U5737 8.8ZN	SCR. M14X2X70 U5737 8.8ZN	VIS M14X2X70 U5737 8.8 ZN	SCHRAUBE M14X2X70 U5737 8.8 ZN	TORNILLO M14X2X70 U5737 8.8 ZN	SURUB M14X 2X 70 U5737 8.8 ZN
11	F01230073	DADO M14X2 D982 8ZN	SELF LOCK NUT M14X2 D982 8ZN	ECROU AUTOBL. M14X2 D982 8ZN	SELBSTSP.MUTT. M14X2 D982 8ZN	TUERCA AUTOBL. M14X2 D982 8ZN	PIULITA AUT. M14X2 D982 8ZN
12	F01200306	DADO M14X2 U5588 6.8ZN	NUT M14X2 U5588 6.8ZN	ECROU M14X2	MUTTER M14X2	DADO M14X2	PIULITA M14X2 5588 6S ZN
13	F01020369	VITE M24X3X90 U5737 10.9ZB	SCREW M24X3X90 U5737 10.9ZB	VIS M24X 3X 90 U5737 10.9ZB	SCHR. M24X 3X 90 U5737 10.9ZB	TORN.M24X 3X 90 U5737 10.9ZB	SURUB M24X 3X 90 U5737 10.9ZB
14	F01230144	DADO M24X3 D982 8ZN	NUT M24X3 D982 8ZN	ECROU M24X 3 D982 8 ZN	MUTTER M24X 3 D982 8 ZN	TUERCA M24X 3 D982 8 ZN	PIULITA M24X 3 D982 8 ZN
15	R17220380	DENTE ATTILA / PINOCCHIO TG.	TOOTH ATTILA/PINOCCHIO TG.	DENT ATTILA / PINOCCHIO TG.	ZAHN ATTILA / PINOCCHIO TG	DIENTE ATTILA / PINOCCHIO TG.	DINTE ATTILA / PINOCCHIO TG.
16	R17820870	ZAPPA EL SX "B" SP. 10 TUNG.	LEFT HEL.BLADE THIKN.10 TUNG.	LAME HELICE GAUCHE ÉP.10 TUNG.	LINK BOGENMESS.DICKE 10 TUNG.	AZADA HEL.IZQUIER.ESP.10 TUNG.	SAPA ELICOIDALA SX SP.10 TUNG.
17	R17820860	ZAPPA EL DX "B" SP. 10 TUNG.	RIGHT HEL. BLADE THIKN. 10TUNG	LAME HELICE DROIT ÉP.10 TUNG.	RECHT BOGENMESS.DICKE 10 TUNG.	AZADA HEL.DERECHA ESP.10 TUNG.	SAPA ELICOIDALA DX SP.10 TUNG.

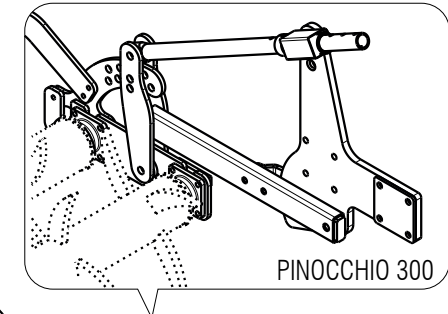

- PINOCCHIO 130 - 3
- PINOCCHIO 170 - 6
- PINOCCHIO 200 - 9
- PINOCCHIO 250 - 11
- PINOCCHIO 300 - 13

- 20
- 37
- 38
- PINOCCHIO 130 - 2
- PINOCCHIO 170 - 5
- PINOCCHIO 200 - 8
- PINOCCHIO 250 - 10
- PINOCCHIO 300 - 12

- 1 - PINOCCHIO 130
- 4 - PINOCCHIO 170
- 7 - PINOCCHIO 200
- 10 - PINOCCHIO 250
- 12 - PINOCCHIO 300

- 14
- 15
- 16
- 17
- 18
- 19
- 20
- 21
- 22
- 23
- 24
- 25
- 26
- 27
- 28
- 29
- 30
- 31
- 32
- 33
- 34
- 35
- 36
- 37
- 38
- 39 - PINOCCHIO 300

**DOPPIO RULLO POSTERIORE MECCANICO / MECHANICAL DOUBLE REAR ROLLER / MECHANISCHE DOPPELTE HINTERE WALZE /
DOUBLE ROULEAU POSTERIEUR MECANIQUE / DOBLE RODILLO POSTERIOR MECANICO / RULOU DUBLU POSTERIOR MECANIC**

TAV. 030

Pos.	Cod.	Descrizione	Description	Description	Benennung	Descripcion	Descriere
1	R17814400	RULLO 20 DENTI 1,3	ROLLER 20 TEETH 1,3	ROULEAU 20 DENTS 1,3	ROLLE 20 ZAHN 1,3	RODILLO DE 20 DIENTES 1,3	ANS.RULOU 1,3 20 DINTI
2	R17814410	RULLO 16 DENTI 1,3	ROLLER 16 TEETH 1,3	ROULEAU A 16 DENTS 1,3	ROLLE 16 ZAHN 1,3	RODILLO DE 16 DIENTES 1,3	ANS.RULOU 1,3 16 DINTI
3	R17814420	SUPPORTO PROTEZIONE	SUPPORT GUARD	SUPPORT PROTECTION	SCHUTZ	SOPORTE PROTECCION	ANSAMBLU SUPORT PROTECTIE
4	R17813480	RULLO 20 DENTI 1,7	ROLLER 20 TEETH 1,7	ROULEAU A 20 DENTS 1,7	ROLLE 20 ZAHN 1,7	RODILLO DE 20 DIENTES 1,7	ANS.RULOU 1,7 20 DINTI
5	R17813490	RULLO 24 DENTI 1,7	ROLLER 24 TEETH 1,7	ROULEAU A 24 DENTS 1,7	ROLLE 24 ZAHN 1,7	RODILLO DE 24 DIENTES 1,7	ANS.RULOU 1,7 24 DINTI
6	R17813470	SUPPORTO PROTEZIONE	SUPPORT GUARD	SUPPORT PROTECTION	SCHUTZ	SOPORTE PROTECCION	ANSAMBLU SUPORT PROTECTIE
7	R17813180	RULLO 24 DENTI 2,0	ROLLER 24 TEETH 2,0	ROULEAU A 24 DENTS 2,0	ROLLE 24 ZAHN 2,0	RODILLO DE 24 DIENTES 2,0	ANS.RULOU 2,0 24 DINTI
8	R17813190	RULLO 28 DENTI 2,0	ROLLER 28 TEETH 2,0	ROULEAU A 28 DENTS 2,0	ROLLE 28 ZAHN 2,0	RODILLO DE 28 DIENTES 2,0	ANS.RULOU 2,0 28 DINTI
9	R17813090	SUPPORTO PROTEZIONE	SUPPORT GUARD	SUPPORT PROTECTION	SCHUTZ	SOPORTE PROTECCION	ANSAMBLU SUPORT PROTECTIE
10	R17813361	RULLO 32 DENTI 2,5	ROLLER 32 TEETH 2,5	ROULEAU A 32 DENTS 2,5	ROLLE 32 ZAHN 2,5	RODILLO DE 32 DIENTES 2,5	ANS.RULOU 32 DINTI 2,5
11	R17813380	SUPPORTO PROTEZIONE	SUPPORT GUARD	SUPPORT PROTECTION	SCHUTZ	SOPORTE PROTECCION	ANSAMBLU SUPORT PROTECTIE
12	R17813371	RULLO 3, 36 DENTI	ROLLER 36 TEETH 300	ROULEAU A 36 DENTS 300	ROLLE 36 ZAHN 300	RODILLO DE 36 DIENTES 300	ANS.RULOU 36 DINTI 300
13	R17813391	SUPPORTO PROTEZIONE	SUPPORT GUARD	SUPPORT PROTECTION	SCHUTZ	SOPORTE PROTECCION	ANSAMBLU SUPORT PROTECTIE
14	F01020152	VITE M12X1,75X40 U5737 8.8ZN	SCR. M12X1,75X40 U5737 8.8ZN	VIS M12X1,75X40 U5737 8.8 ZN	SCHRAUBE M12X1,75X40U57378.8ZN	TORNIL.M12X1,75X40 U5737 8.8ZN	SUR. M12X1,75X40 U5737 8.8ZN
15	R17813120	LAMA DI REGOLAZIONE	BLADE ADJUSTMENT	LAME REGLAGE	HALTERUNG MESSER	CUCHILLA SOPORTE	LAMA DE REGLARE
16	R17813110	ASSIME SUPORTO RULLO	ROLLER SUPPORT	SOPORTE ROULEAU	ROLLE HALTERUNG	SOPORTE RODILO	ANS.SUPPORT RULOU
17	R17813240	PIASTRA DI ATTACCO	FIXING PLATE	PLAQUE DE RACCORD	KUPPLUNGSPLATTE	PLACA DE CONEXIN	PLACA DE POZITONARE
18	F04100073	SUPPORTO CUSCINETTO FY35TF	BEARING SUPPORT FY35TF	SUPPORT ROULEMENT FY35TF	LAGERHALTERUNG FY35TF	SOPORTE COJINETE FY35TF	SUPPORT RULMENT FY35TF
19	F01020262	VITE M16X2X80 U5737 8.8ZN	SCR. M16X2X80 U5737 8.8ZN	VIS M16X2X80 U5737 8.8 ZN	SCHRAUBE M16X2X80 U5737 8.8 ZN	TORNILLO M16X2X80 U5737 8.8 ZN	SURUB M16X 2X 80 U5737 8.8 ZN
20	F01230059	DADO M12X1,75 D982 8ZN	LOCK-NUT M12X1,75 D982 8ZN	ECR.AUTO-FREI.M12X1,75 D982 ZN	SICHERUNGSMUT.M12X1,75 D982 8ZN	TUER.DE SEGUR.M12X1,75 D982 ZN	PIULITA M12X 1,75 D982 8 ZN
21	F01020160	VITE M12X1,75X60 U5737 8.8ZN	SCR. M12X1,75X60 U5737 8.8ZN	VIS M12X1,75X60 U5737 8.8 ZN	SCHRA.M12X1,75X60 U5737 8.8 ZN	TORN. M12X1,75X60 U5737 8.8 ZN	SURUB M12X1,75X 60 5737 8.8 ZN
22	F01020325	VIT.M20X 2,5X 90 U5737 10.9 ZD	SCR. M20X2,5X90 U5737 10.9ZD	VIS M20X 2,5X 90 U5737 10.9 ZD	SCH.M20X 2,5X 90 U5737 10.9 ZD	TOR.M20X 2,5X 90 U5737 10.9 ZD	SUR.M20X 2,5X 90 U5737 10.9 ZD
23	F01410124	ROS.M20 21X 37X 3 U6592 ZN	WASHER M20 21X 37X 3 U6592 ZN	RONDEL.M20 21X 37X 3 U6592 ZN	MUTTER M20 21X 37X 3 U6592 ZN	ARANDELA M20 21X37X3 U6592 ZN	SAIBA M20 21X 37X 3 U6592 ZN
24	F01230131	DADO M20X2,5 D982 6ZN	NUT M20X2,5 D982 6ZN	ECROU M20X,5 D982 6ZN	MUTTER M20X2,5 D982 6ZN	TUERCA M20X2,5 D982 6ZN	PIULITA M20X2,5 D982 6ZN
25	F01020285	VITE M16X2X100 U5737 8.8ZN	SCR. M16X2X100 U5737 8.8ZN	VIS M16X2X100 U5737 8.8 ZN	SCHR.M16X2X100 U5737 8.8 ZN	TORN.M16X2X100 U5737 8.8 ZN	SURUB M16X2X100 U5737 8.8 ZN
26	F01230085	DADO M16X2 D982 8ZN	NUT M16X2 D982 8ZN	ECROU M16X2 D982 8ZN	MUTTER M16X2 D982 8ZN	TUERCA M16X2 D982 8ZN	PIULITA M16X2 D982 8ZN
27	R17815180	PIASTRA SUPPORTO RULLO	ROLLER PLATE SUPPORT	PLAQUE SOPORTE ROULEAU	ROLLE HALTERUNG PLATE	PLACA SOPORTE RODILLO	PLACA SUPORT RULOURI
28	R17813140	ASS.SUPPORTO RULLO	ROLLER SUPPORT	SUPPORT ROULEAU	ROLLE HALTRUNG	SOPORTE RODILLO	ANS.SUPPORT RULOU
29	R17813130	PIATTO ATTACCO	SUPPORT PLATE	PLAQUE DE SUPPORT	HALTERUNG PLATTE	PLACA DE SOPORTE	PLACA SUPORT
30	R17813230	BOCCOLA	BUSHING	BUSHING	BUCHSE	CASQUILLO	BUCSA DISTANTATOARE
31	R17811910	TUBO REGOLAZIONE	ADJUSTMENT PIPE	TUBE REGLAGE	ROHR EINSTELLUNG	TUBO REGULACIN	TUB REGLAJ
32	R17811960	BOCCOLA PER REGOLAZIONE ZN	BUSHING ADJUSTMENT ZN	BOITE REGLAGE ZN	EINSTELLBUCHSE ZN	CASQUILLO REGULACIN ZN	BUCSA PENTRU REGLARE ZN
33	R17811950	TUBO REGOLAZIONE ZN	ADJUSTMENT TUBE ZN	TUBE REGLAGE ZN	ROHR EINSTELLUNG ZN	TUBO REGULACIN ZN	ANSAMBLU TUB REGLARE ZN
34	F02200562	SPINA SICUR. D.8X70 ZN	SNAP PIN D.8X 70 ZN	FICHE EL. D.8X70 ZN	SCHERSTIFT D.8X 70 ZN	CLAVIJA D.8X 70 ZN	STIFT RESORT D.8X70 ZN
35	R17812000	BOCCOLA 21,7X33,7X23 ZN	BUSHING 21,7X33,7X23 ZN	BUSHING 21,7X33,7X23 ZN	BUCHSE 21,7X33,7X23 ZN	CASQUILLO 21,7X33,7X23 ZN	BUCSA 21,7X33,7X23 ZN
36	F01020260	VITE M16X2X70 U5737 8.8ZN	SCR. M16X2X70 U5737 8.8ZN	VIS M16X2X70 U5737 8.8 ZN	SCHRAUBE M16X2X70 U5737 8.8 ZN	TORNILLO M16X2X70 U5737 8.8 ZN	SURUB M16X2X70 U5737 8.8 ZN
37	R17843580	ASSIEME SUPPORTO	ASSEMBLY SUPPORT	ASSEMBLEE SUPPORT	HALTERUNG ZUSAMMENBAU	ASAMBLEA SUPPORTO	ANSAMBLU SUPORT
38	F20110745	CAV.Q.B=70 M=12X1,75L=96	U BOLT Q.B=70 M=12X1,75 L=96	CAVALIER M12 POUR TUBE 70X70	BsGELBOLZEN M12 Fsr ROHR 70X70	PERNO EN U M12 X TUBO 70X70	BRIDA "U" M12 PT TUB 70X70 ZN
39	R17812620	PIASTRA ATTACCO	ATTACHMENT PLATE	PLAQUE POIGNEE	PLATTE GRIFF	PLACA AGARRE	PLACA PRINDERE

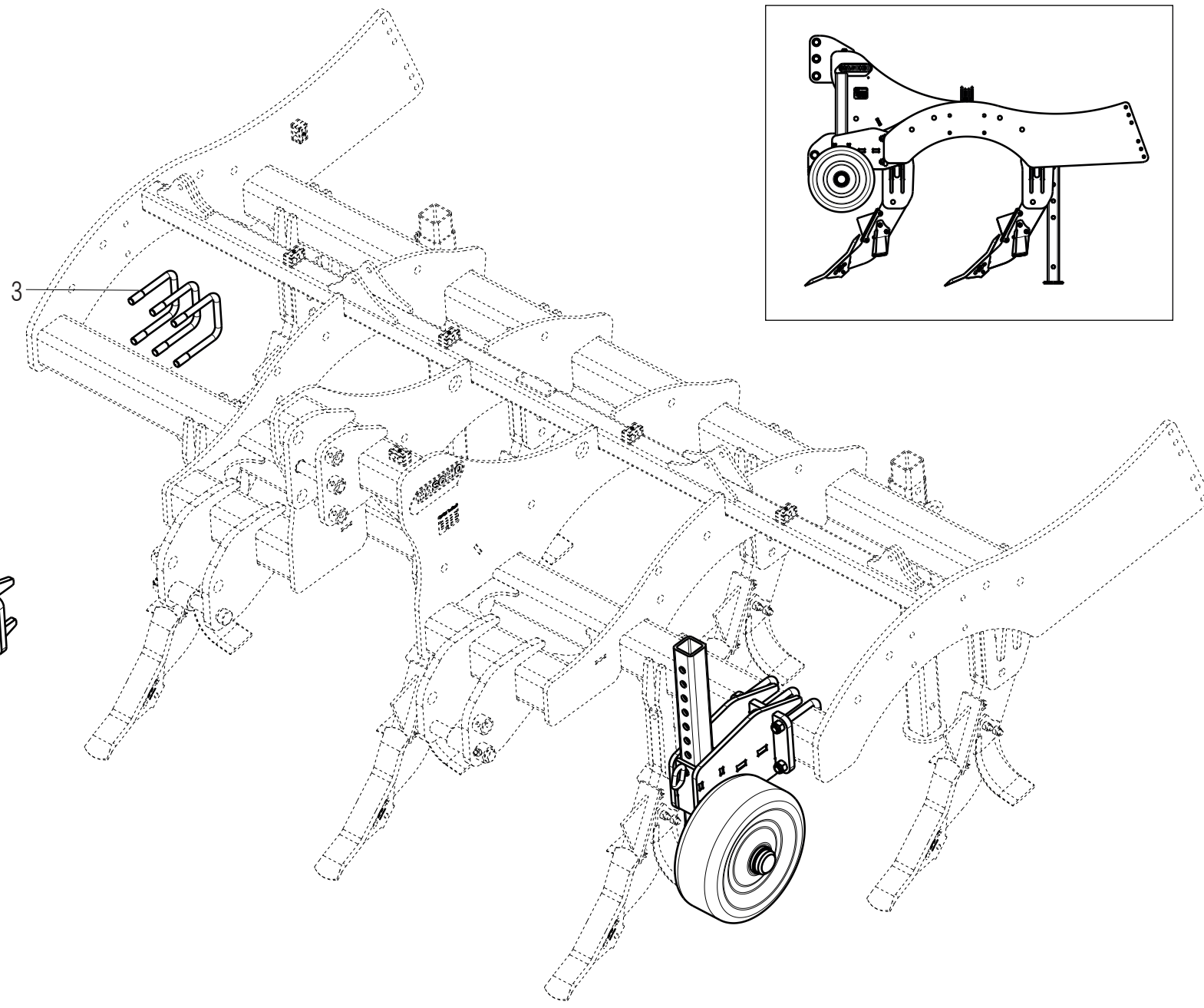

**RUOTE DI PROFONDITÀ / DEPTH WHEEL / TIEFENRAD / ROUE DE PROFONDEUR /
RUEDA DE PROFUNDIDAD / ROATĂ DE ADÂNCIME**

TAV. 040

Pos.	Cod.	Descrizione	Description	Description	Benennung	Descripcion	Descriere
1	R17616130	ASSIEME SUPP. RUOTA DI PROF.	IRON WHEEL SUPPORT SET	ENSEMBLE SOUTIEN ROUE PROF.	STÜTZRAD TIEFE	ASAMBLEA APOYO RUEDA	ANSAMBLU SUPORT ROATA PROF.
2	R18012160	ASSIEME RUOTA	ASSEMBLY WHEEL	ASSEMBLEE ROUE	TIEFENRAD	ASAMBLEA RUEDA	ANSAMBLU ROATA
3	R18120091	CAVALLOTTO M 20 ZN	U BOLT M20	ATTELAGE M20 ZN	ANSCHLAG STREUER M20 ZN	ELEMENTO DE EMPALME M20 ZN	BRIDA U M20 ZN
4	R17810440	PERNO D20 L105 ZN	BOLT D20 L105 ZN	BOULON D20 L105 ZN	BOLZEN D20 L105 ZN	PERNO D20 L105 ZN	BOLT D20 L105 ZN
5	F02200507	SPINA A SCATTO D9 B/83 ZN	SNAP PIN D9 B/83 ZN	FICHE A DETENTE D9 B/83 ZN	EINRASTSTIFT D9 B/83 ZN	CLAVIJA DE MUELLE D9 B/83 ZN	STIFT RESORT D9 B/83 ZN
6	F01220092	DADO M20X2,5 D980 8ZN	NUT M20X2,5 D980 8ZN	ECROU M20X 2,5 D980 8 ZN	MUTTER M20X 2,5 D980 8 ZN	TUERCA M20X 2,5 D980 8 ZN	PIULITA M20X 2,5 D980 8 ZN

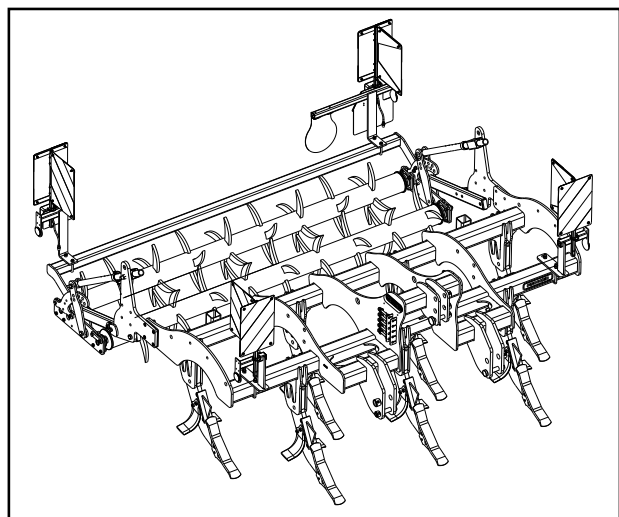
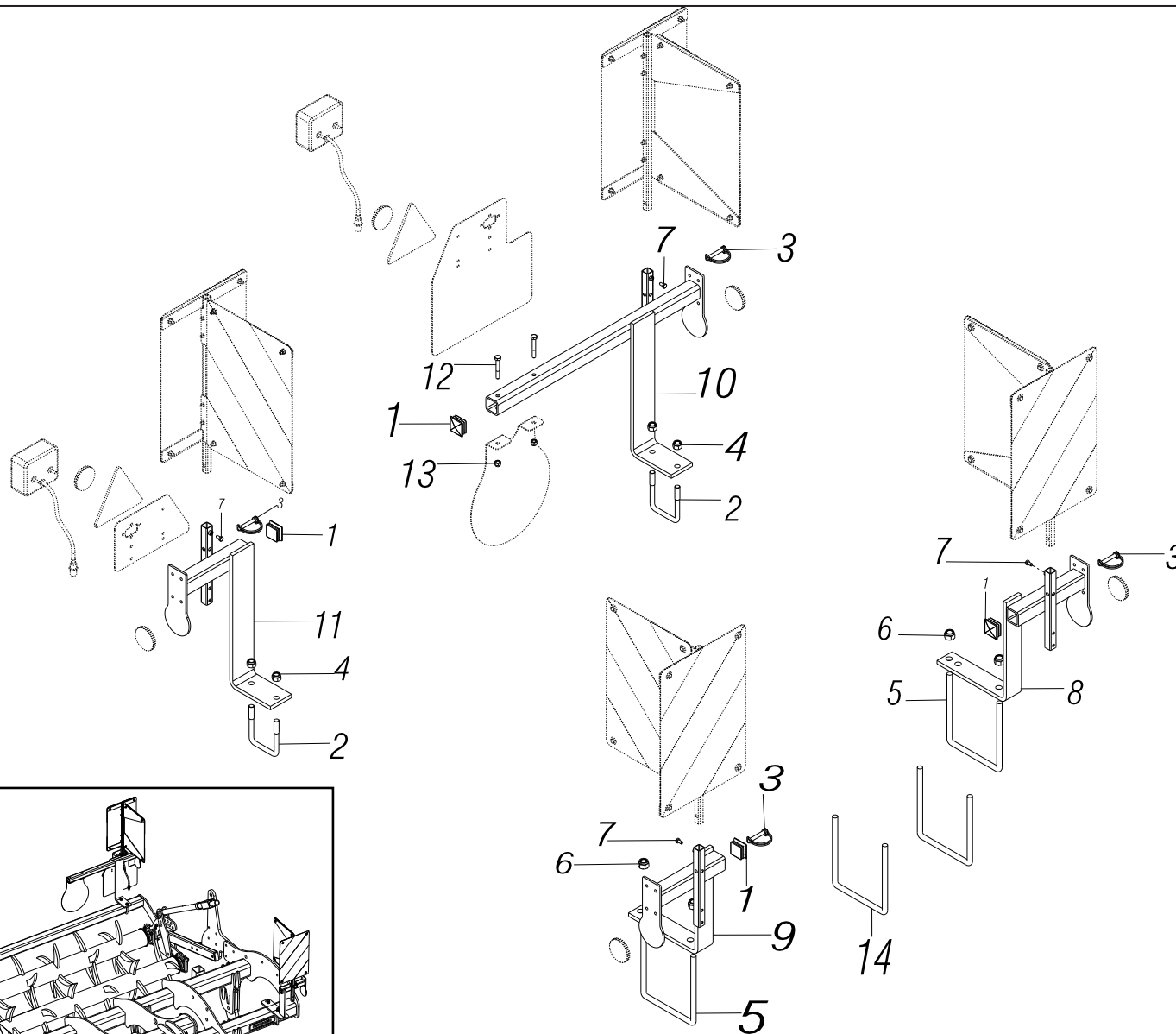

NOTA :

Pentru Artiglio CSS / Magnum se folosesc bridele poz. 5 iar pentru Attila CSS / Pinocchio CSS bridele poz. 14.

Per Artiglio CSS / Magnum si usano cavallotti pos. 5 e per Attila CSS / Pinocchio CSS cavallotti pos. 14.

For Artiglio CSS / Magnum use Sq. U bolt pos. 5 and for Attila CSS / Pinocchio CSS use Sq. U bolt pos. 14.

**KIT STAFFE LUCI / LIGHTS SUPPORTS KIT / LICHTER HALTER KIT / KIT SUPPORT D'ECLAIRAGE /
KIT SOPORTE DE ILUMINACION / KIT SUPORT LUMINI**

TAV. 050

Pos.	Cod.	Descrizione	Description	Description	Benennung	Descripcion	Descriere
1	F05100023	TAPPO AD ALETTE 40X40 PLT NERO	PLUG 40X40	BOUCHON FERMETURE 40X40	VERSCHLUSSPFROPFEN 40X40	TAPONCLAUSURA 40X40	DOP PALETE 40X40 PLT NEGRU
2	F20110745	CAV.Q.B=70 M=12X1,75L=96	U BOLT Q.B=70 M=12X1,75 L=96	CAVALIER M12 POUR TUBE 70X70	BsGELBOLZEN M12 FsR ROHR 70X70	PERNO EN U M12 X TUBO 70X70	BRIDA "U" M12 PT TUB 70X70 ZN
3	F02200562	SPINA SICUR. D.8X70 ZN	SNAP PIN D.8X 70 ZN	FICHE EL. D.8X70 ZN	SCHERSTIFT D.8X 70 ZN	CLAVIJA D.8X 70 ZN	STIFT RESORT D.8X70 ZN
4	F01230059	DADO M12X1,75 D982 8ZN	LOCK-NUT M12X1,75 D982 8ZN	ECR.AUTO-FREI.M12X1,75 D982 ZN	SICHERUNG.MUT.M12X1,75 D982 8ZN	TUER.DE SEGUR.M12X1,75 D982 ZN	PIULITA M12X 1,75 D982 8 ZN
5	F20110775	CAV.Q.B=120 M=14X2 L=159	U BOLT Q.B=120M14X2L=159	BRIDE U M14X2X50 135X159 ZN	ANSCHLAG U M14X2X50 135X159 ZN	EL.EMPALM.U M14X2X50 135X159ZN	BRIDA U M14X2X50 135X159 ZN
6	F01230073	DADO M14X2 D982 8ZN	SELF LOCK NUT M14X2 D982 8ZN	ECROU AUTOBL. M14X2 D982 8ZN	SELBSTSP.MUTT. M14X2 D982 8ZN	TUERCA AUTOBL. M14X2 D982 8ZN	PIULITA AUT. M14X2 D982 8ZN
7	F01020398	VITE M6X1X12 U5739 8.8ZN	SCR. M6X1X12 U5739 8.8ZN	VIS M6X 1X12 U5739 8.8 ZN	SCHRAUBE M6X 1X12 U5739 8.8 ZN	TORNILLO M6X 1X12 U5739 8.8 ZN	SURUB M 6X 1X 12 U5739 8.8 ZN
8	R17640710	SUPPORTO LUCI ANTERIORE SX	SUPPORT FRONT LIGHTS LEFT	SUPPORT PHARES AVANT GAUCHE	LINK HALTERUNG FRONT LEUCHTEN	LUCES DE FRENT DE APOYO IZQ.	SUPPORT LUMINI ANTERIOR SX
9	R17640501	SUPPORTO LUCI ANTERIORE DX	SUPPORT FRONT LIGHTS RIGHT	SUPPORT PHARES AVANT DROIT	RECHT HALTERUNG FRONT LEUCHTEN	LUCES DE FRENT AE APOYO DERE.	SUPPORT LUMINI FATA DX
10	R17640720	SUPPORTO LUCI POSTERIORE SX	SUPPORT POST. LIGHTS LH	SUPPORT PHARES POST. GAUCHE	LINK HALTERUNG POST. LEUCHTEN	LUCES APOYO ATRAS IZQ.	SUPPORT LUMINI POSTERIOR SX
11	R17640491	SUPPORTO LUCI POSTERIORE DX	SUPPORT POST. LIGHTS RH	SUPPORT PHARES POST. DROIT	RECHT HALTERUNG POST. LEUCHTEN	LUCES APOYO ATRAS DERECHA	SUPPORT LUMINI POSTERIOARE DX
12	F01020075	VITE M8X1,25X55 U5737 8.8ZN	SCR. M8X1,25X55 U5737 8.8ZN	VIS M8X1,25X 55 U5737 8.8 ZN	SCHRAU. M8X1,25X55 U5737 8.8ZN	TORNIL. M8X1,25X55 U5737 8.8ZN	SURUB M8X1,25X 55 U5737 8.8ZN
13	F01230034	DADO M8X1,25 D982 8ZN	NUT M8X1,25 D982 8ZN	ECROU M8X 1,25 D982 8 ZN	MUTTER M8X 1,25 D982 8 ZN	TUERCA M8X 1,25 D982 8 ZN	PIULITA M8X 1,25 D982 8 ZN

**USATE SEMPRE RICAMBI ORIGINALI
ALWAYS USE ORIGINAL SPARE PARTS
IMMER DIE ORIGINAL-ERSATZTEILE VERWENDEN
EMPLOYEZ TOUJOURS LES PIECES DE RECHANGE ORIGINALES
UTILIZAR SIEMPRE REPUESTOS ORIGINALES
UTILIZAȚI ÎNTOTDEAUNA PIESE DE SCHIMB ORIGINALE**

MASCHIO

GASPARDO

MASCHIO

GASPARDO

Sede legale e stabilimento produttivo

Via Marcello, 73 - 35011
Campodarsego (PD) Italy
Tel. +39 049 9289810
Fax +39 049 9289900

www.maschionet.com

MASCHIO DEUTSCHLAND GMBH

Äußere Nürnberger Straße 5
D - 91177 Thalmässing
Deutschland
Tel. +49 (0) 9173 79000
Fax +49 (0) 9173 790079
@maschio.de
www.maschionet.com

1, Rue Denis Papin
45240 La Ferte St. Aubin France
Tel. +33 (0) 2.38.64.12.12
Fax +33 (0) 2.38.64.66.79
info@maschio.fr
www.maschionet.com

**MASCHIO GASPARDO North
America, Inc**

112 3rd Avenue East
DeWitt, IA 52742 (USA)
Phone: (563) 659-6400
Fax: (563) 659-6404
info@maschio.us
www.maschionet.com

**Maschio Gaspardo (Qingdao)
Agriculture Machinery Co Ltd**

South of 5# Road, Fuyuan Industrial Park,
ETDZ Huangdao - 266500 Qingdao,
Shandong Province, China
Tel: +86 532 86918691
Fax: +86 532 86918690
e-mail: info@maschio.cn
www.maschionet.com

MASCHIO GASPARDO IBERICA S.L.

Ronda General Mitre, 28-30
08017 Barcelona Espana
Tel. +34 93.81.99.058
Fax +34 93.81.99.059
e-mail: info@maschio.es
www.maschionet.com

MASCHIO GASPARDO ROMANIA SRL

Strada Înfrățirii, Nr. 155
315100 Chişineu - Criş
Tel. +40 257 30 70 30
Fax. +40 257 30 70 40
e-mail: info@maschio.ro
www.maschionet.com

ООО МАСКИО-ГАСПАРДО РУССИЯ
404126, Россия, Волгоградская
область,
г.Волжский, ул.Пушкина, 117 *6*.
Тел.: +7 (8443) 203100
факс: +7 (8443) 203101
e-mail: info@maschio.ru
www.maschionet.com

**GASPARDO-MASCHIO TARIM
MAKİNALARI SAN. ve TİC.
LTD. ŞTİ.**

İzmir-Aydın Asfaltı, No:39 Yazıbaşı,
Torbalı-İZMİR / TÜRKİYE
Tel: +90 232 8537050
Fax: +90 232 8537385
e-mail: info@maschio.com.tr
www.maschionet.com

**ТОВ
«МАСКІО – ГАСПАРДО УКРАЇНА»**

04119 Україна, м.Київ, вул. Зоологічна,
4-А, оф.139
Тел. +380 44 538 18 38,
Факс +380 44 538 08 20
e-mail: info@maschio.com.ua
www.maschionet.com

**MASCHIO-GASPARDO POLAND
Sp. z o.o.**

ul. Wapienna 6/8
87-100 Toruń - Polska
Tel. +48 56 650 60 51
Fax +48 56 650 60 53
email: info@maschio.pl
www.gaspardo.pl

**MASCHIO GASPARDO S.p.A.
Production Plant**

Morsano al Tagliamento (PN)
Via Mussons, 7 – 33075 Morsano al Tagliamento
(Pordenone) – Italy
Tel. +39 0434 695410
Fax +39 0434 695425
e-mail: info@gaspardo.it
www.maschionet.com



F07011325