

FERABOLI

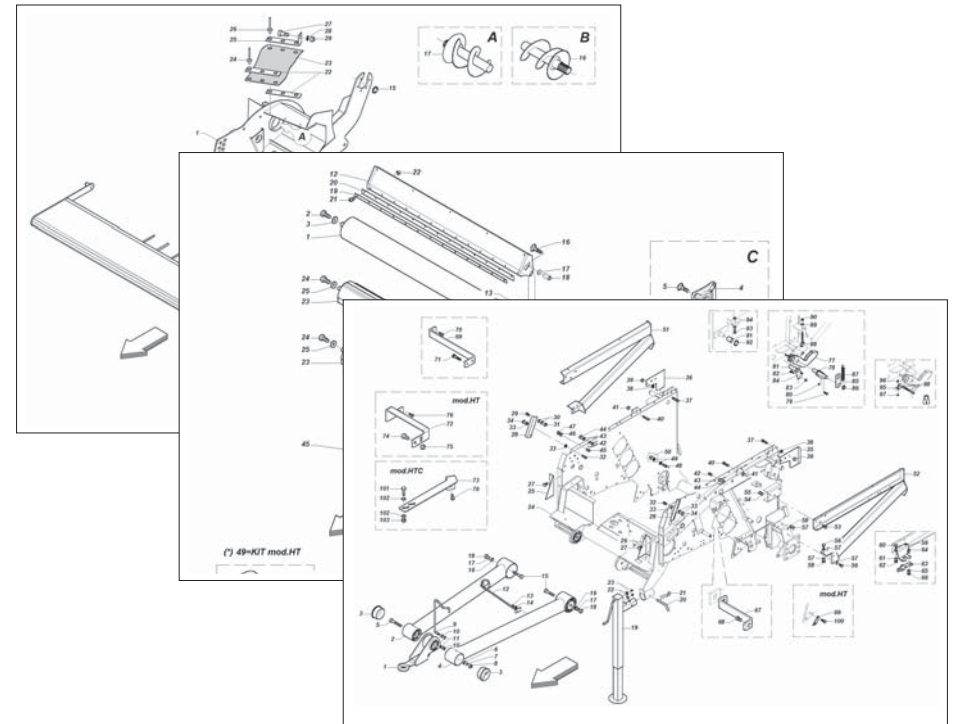

EXTREME 265 HTC

VARIO TRONIC

Cod: B0D5P0036 2003-11

- *) Valido per Paesi UE
- *) Valid for EU member countries
- *) Valable dans les Pays UE
- *) Gilt für EU-Mitgliedsländer
- *) Válido para Países UE

- IT** PARTI DI RICAMBIO
- EN** SPARE PARTS
- DE** ERSATZTEILE
- FR** PIÈCES DÉTACHÉES
- ES** PIEZAS DE REPUESTO

PARTI DI RICAMBIO

Le ordinazioni delle parti di ricambio vanno fatte presso i nostri concessionari di zona e devono essere sempre corredate dalle seguenti indicazioni:

- **Tipo, modello e numero di matricola dell'attrezzatura.** Tali dati sono stampigliati nell'apposita targhetta di cui è dotata ogni attrezzatura.

- **Numero di codice della parte richiesta** rilevabile dal catalogo ricambi.

- **Descrizione del particolare e quantità richiesta.**

- **Numero della tavola.**

- **Mezzo di trasporto.** Nel caso questa voce non sia specificata, la Ditta Costruttrice, pur dedicando a questo servizio una particolare cura, non risponde di eventuali ritardi di spedizione dovuti a cause di forza maggiore.

Le spese di trasporto si intendono sempre a carico del destinatario. La merce viaggia a rischio e pericolo del committente anche se venduta franco destino.

NOTA: Il termine **(Dx) Destro** o **(Sx) Sinistro** della macchina o di parti di essa, è inteso guardando la macchina dalla parte posteriore. Le eccezioni saranno indicate.

SPARE PARTS

Orders must be transmitted through our area dealers and should always include the following indications:

- **Type, model and serial number of the machine.** *These data are punched on the data plate with which every implement is equipped.*

- **Code number of the required spare part.** *This will be found in the spare parts catalogue.*

- **Description of the part and required quantity.**

- **Table number.**

- **Means of dispatch.** *If this item is not indicated, the Manufacturer, while dedicating particular care to this service, shall not be held responsible for delays in delivery caused by cases of force majeure.*

Transport expenses shall always be at the consignee's charge. The goods travel at the purchaser's risk and peril even when sold ex destination.

NOTE: *The symbols (Dx) right and (Sx) left, concerning the machine or single parts of it, are referred, as in the figure, to a rear view of them. Exceptions will be indicated.*

ERSATZTEILE

Die Bestellungen müssen bei unseren Gebietshändlern aufgegeben werden. Bei der Bestellung sind stets die folgenden Angaben zu machen:

- **Typ, Modell und Serien-Nummer des Geräts.** Diese Daten stehen auf dem Typenschild, mit dem jedes Gerät versehen ist.

- **Artikel Nr. der erforderlichen Ersatzteile.** Diese stehen im Ersatzteil-Katalog.

- **Beschreibung des Ersatzteils und die erforderliche Stückzahl.**

- **Tafelnummer.**

- **Versandmittel.** Wenn dieser Punkt nicht spezifiziert wird, haftet die Herstellerfirma nicht für etwaigen Lieferverzug aufgrund höherer Gewalt, auch wenn er diesen Service besonders aufmerksam abwickelt.

Die Frachtkosten gehen dagegen immer zu Lasten des Empfängers. Die Ware reist auf Gefahr und Risiko des Auftraggebers, auch wenn frei Haus Verkauft vereinbart worden ist.

N.B.: Die Merkzeichen **(Dx) rechts** und **(Sx) links** betreffen eine rückwärtige Aussicht der Maschine oder Teile von ihr (siehe Bild). Ausnahmen werden gezeit.

PIECES DÉTACHÉES

Les ordres doivent être effectués auprès de nos concessionnaires de zone en précisant les indications suivantes:

- **Type, modèle et numéro de série de la machine.** *Ces données sont gravées sur la plaque d'identification de chaque outil.*

- **Numéro de code de la pièce détachée** *indiqué sur le catalogue des pièces détachées.*

- **Description de la pièce et quantité requise.**

- **Numéro de plan.**

- **Moyen d'expédition.** *Si cette rubrique n'est pas indiquée, le Constructeur, bien que soucieux de ce service, ne répond pas des retards d'expédition pour des causes de force majeure.*

Les frais de transport sont toujours à la charge du destinataire. La marchandise voyage aux risques et périls de l'acheteur même si vendue franco de port.

N.B.: *Les références (Dx) droit et (Sx) gauche de la machine ou des parties de la même, est entendue, comme de la figure, en regardant la machine de derriere dans le sens de marche.*

RESPUESTOS

Los pedidos han de efectuarse en nuestros concesionarios de zona y deben incluir siempre las siguientes indicaciones:

- **Tipo, modelo y número de matrícula del equipo.** Dichos datos están impresos en la relativa placa presente en el equipo.

- **Número de código de la parte requerida** presente en el catálogo respuestos.

- **Descripción de la pieza y cantidad requerida.**

- **Numero de ilustración.**

- **Medio de transporte.** En caso que este ítem no esté especificado, el Fabricante, aún prestando la debidas consideraciones para este aspecto, no responde por eventuales retardos de env'o debidos a causas de fuerza mayor.

Los gastos de transporte se consideran siempre a cargo del destinatario. La mercadería viaja bajo riesgo y peligro del comprador, incluso cuando se vende franco destino.

N.B.: La referencia **(Dx) derecha** o **(Sx) izquierda** de la máquina o de sus componentes, se entiende, como en la figura, mirando la máquina por la parte trasera. Se indicarán las excepciones.

INDEX

N° Table

TAV_P000001_01-HTC
TAV_P000002_01-265
TAV_P000004_01-265
TAV_P000045_00
TAV_P000006_01
TAV_P000009_00-1
TAV_P000125_00
TAV_P000007_02
TAV_P000010_01-265
TAV_P000011_01-265
TAV_P000014_02-3
TAV_P000015_01
TAV_P000016_02
TAV_P000017_01
TAV_P000026_01
TAV_P000027_01
TAV_P000019_01
TAV_P000020_00-1-M
TAV_P000020_00-1-L
TAV_P000022_01-M
TAV_P000022_01-L
TAV_P000024_00
TAV_P000025_00-M
TAV_P000025_00-L
TAV_P000028_01-265
TAV_P000048_01
TAV_P000044_01
TAV_P000029_03
TAV_P000031_01
TAV_P000109_00
TAV_P000057_01
TAV_P000123_00
TAV_P000032_00-2
TAV_P000033_00
TAV_P000034_00
TAV_P000036_00
TAV_P000037_01
TAV_P000040_01
TAV_P000043_00
TAV_P000049_02
TAV_P000050_00-HT

Description

“Telaio inf.+ timone + roolbar + ganci Extreme 265-280 HTC”
“Telaio superiore Extreme 265”
“Portellone + II° bilancere Extreme 265”
“Segnalatori di caricamento Extreme 265-280”
“Ruote Extreme”
“Scatola di trasmissione Extreme HTC”
“Rulli (solo per leg.rete 2 rulli) Extreme HT-HTC”
“Rulli Extreme HT/HTC”
“Trasmissione:catene+tenditori+guida Extreme 265 HT-HTC”
“Bilancere Extreme 265”
“Cut 13: telaio + rotore Extreme HTC-LTC”
“Cut 13: traversa coltelli Extreme HTC”
“Cut 25: telaio + rotore Extreme HTU”
“Cut 25: traversa coltelli Extreme HTU”
“Sicurezza trasm. bullone-meccanica Extreme HTC-LTC”
“Sicurezza trasm. “AFC” automatica Extreme 265-280 HTC”
“Telaio pick-up - M/L + lamiera Extreme HTC”
“Aspo pick-up M Extreme”
“Aspo pick-up L Extreme”
“Trasmissione HTC - pick-up M Extreme HTC”
“Trasmissione HTC - pick-up L Extreme HTC”
“Impianto idraulico pick-up Extreme HTC-LTC”
“Ruotine pivottanti pick-up M Extreme”
“Ruotine pivottanti pick-up L Extreme”
“Impianto idraulico macchina Extreme HT-HTC 265”
“Valvola geometria/pressione Extreme”
“Centralina/Cablaggio Extreme HT-HTC”
“Legatore filo Extreme”
“Cassonetto filo Extreme 265-280”
“Carter solo filo Extreme”
“Kit legatore rete 2rulli Extreme”
“Leg. rete 2rulli:sgancio+coll. Extreme”
“Legatore rete 1rullo: braccio rete + braccio lama”
“Legatore rete: sgancio + collegamenti (EX)”
“Leg. rete:cassonetto+filo Extreme”
“Oliatura automatica Extreme HTC”
“Carter anteriori Extreme 265 HT-HTC”
“Carter laterali Extreme 265 HT-HTC”
“Impianto luci Extreme”
“Kit allontanatore balla Extreme”
“Graffatura Extreme HT”

N° Table

TAV_P000051_01
TAV_P000052_00
TAV_P000053_00
TAV_P000054_00
TAV_P000055_00
TAV_P000056_00
TAV_P000135_00
TAV_P000138_00
TAV_P000139_00

Description

“Kit cassonetto suppl.per bobine filo Extreme 265-280”
“Kit staffe portarotolo rete suppl. Extreme”
“Kit finti coltelli Extreme HTC”
“Kit film plastico Extreme”
“Dispositivo sicurezza meccanico Extreme”
“Dispositivo sicurezza idraulico Extreme”
“Decal “logo” Extreme 265-HT-HTC”
“Decal “CE” Extreme”
“Decal “istruzioni” Extreme”

TAV_P000001_01-HTC

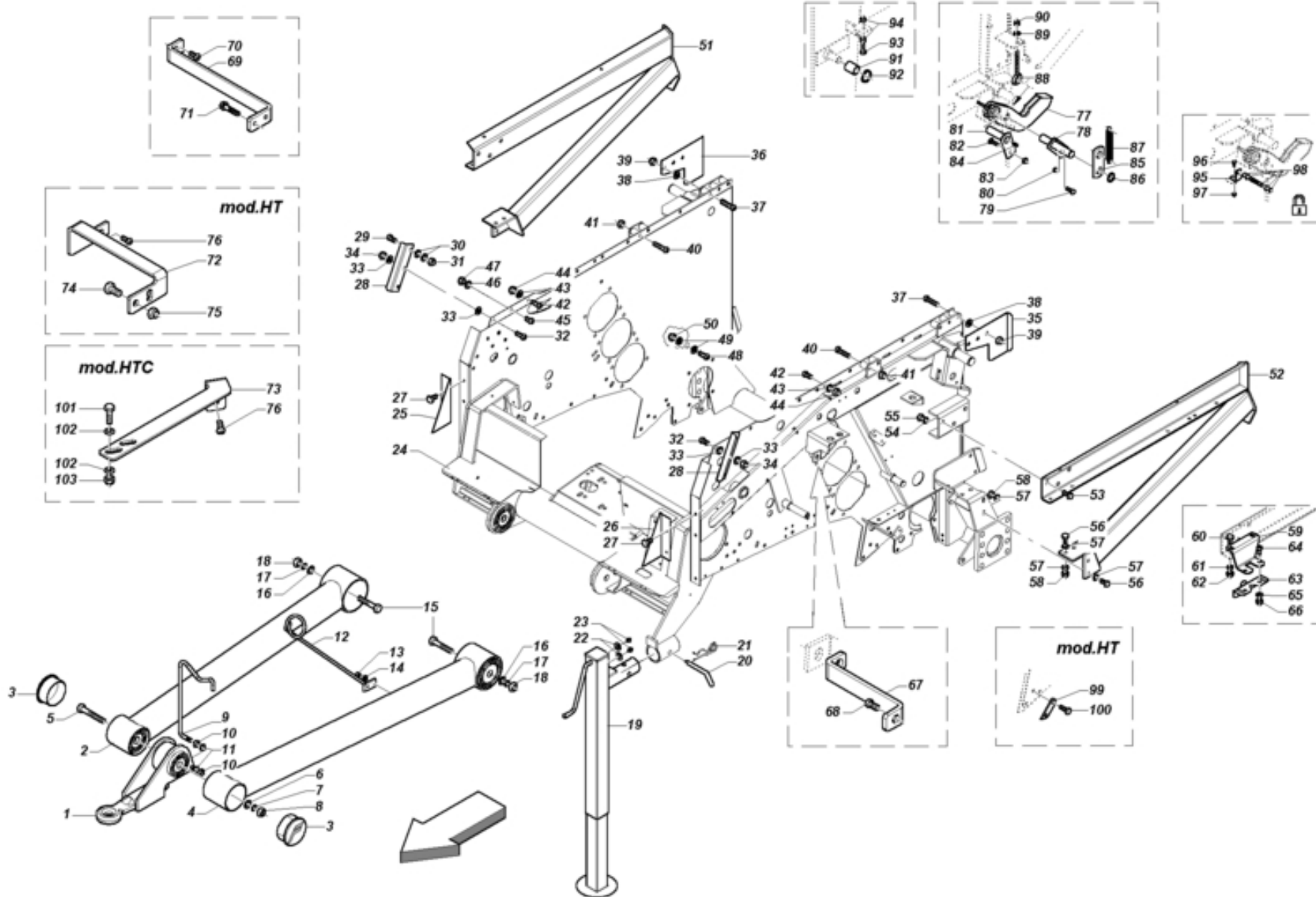

TAV_P000001_01-HTC

Item	Part Num.	Description	Item	Part Num.	Description
p001	7S01750	TOWING EYE ø35	p024	7S01532	LOWER FRAME
p002	7S01751	RIGHT DRAW BAR FLANGE	p025	C005036	RIGHT FRONT LOCK
p003	7V00099	PLUG FOR TOWING EYE	p026	C005035	LEFT FRONT LOCK
p004	7S01843	LEFT DRAW BAR FLANGE	p027	0180820	SCREW
p005	0172497	SCREW	p028	C005026	FRAME STIFFENING
p006	14R2440	WASHER	p029	0471230	SCREW
p007	1622450	WASHER	p030	1421230	WASHER
p008	0740724	NUT	p031	0920412	NUT
p009	C005121	CARDAN SHAFT SUPPORT	p032	0471225	SCREW
p010	0920412	NUT	p033	1421230	WASHER
p011	1421230	WASHER	p034	0920412	NUT
p012	7S01825	HOSE SUPPORT	p035	C004488	LEFT HOOK GUARD
p013	0471025	SCREW	p036	C004506	RIGHT HOOK GUARD
p014	1421025	WASHER	p037	0471280	SCREW
p015	0172480	SCREW	p038	1421230	WASHER
p016	14R2440	WASHER	p039	0920412	NUT
p017	1622450	WASHER	p040	0471280	SCREW
p018	0740724	NUT	p041	0920412	NUT
p019	7S01755	DRAW BAR STAND	p042	0471225	SCREW
p020	13C0001	PIN	p043	1421230	WASHER
p021	11B0499	PIN	p044	0920412	NUT
p022	1420820	WASHER	p045	0471220	SCREW
p023	4200810	GREASE	p046	1421230	WASHER

TAV_P000001_01-HTC

Item	Part Num.	Description	Item	Part Num.	Description
p047	0920412	NUT	p070	04N0820	SCREW
p048	0471225	SCREW	p071	0370001	SCREW
p049	1431225	WASHER	p073	C4P0004	CUT RIGHT LOWER EDGE SUPPORT
p050	0920412	NUT	p076	04N0820	SCREW
p051	7S01663	RIGHT ROLL FRAME	p077	7S01772	REAR GATE HOOK
p052	7S01550	LEFT ROLL FRAME	p078	7S01757	REAR GATE CYLINDER PIN
p053	0181635	SCREW	p079	0180825	SCREW
p054	1421630	WASHER	p080	0920208	NUT
p055	0920516	NUT	p081	7S00937	TAILGATE HOOK PIN
p056	0181235	SCREW	p082	0180825	SCREW
p057	1421230	WASHER	p083	0920208	NUT
p058	0920412	NUT	p084	4200610	GREASE NIPPLE
p059	C005184	CLOSURE COUPLING	p085	C004902	STIFFENING
p060	0181035	SCREW	p086	1700020	SEEGER RING
p061	1421025	WASHER	p087	1826161	SPRING
p062	0545790	SELF-LOCKING NUT	p088	0545168	EYELET M12
p063	1800041	LOCK	p089	1421230	WASHER
p064	04N0820	SCREW	p090	0920412	NUT
p065	1420820	WASHER	p091	1300612	SPACER
p066	0920208	NUT	p092	1700030	SEEGER RING
p067	C005203	GUARD LEFT SIDE SUPPORT	p093	0181260	SCREW
p068	04N0820	SCREW	p094	0710412	NUT
p069	C005197	GUARD RIGHT SIDE SUPPORT	p095	C004245	SUPPORT



TAV_P000001_01-HTC

Item	Part Num.	Description	
p096	0181020	SCREW	
p097	0545790	SELF-LOCKING NUT	
p098	E000056	PROXIMITY SENSOR	
p101	0181230	SCREW	
p102	1421230	WASHER	
p103	0920412	NUT	

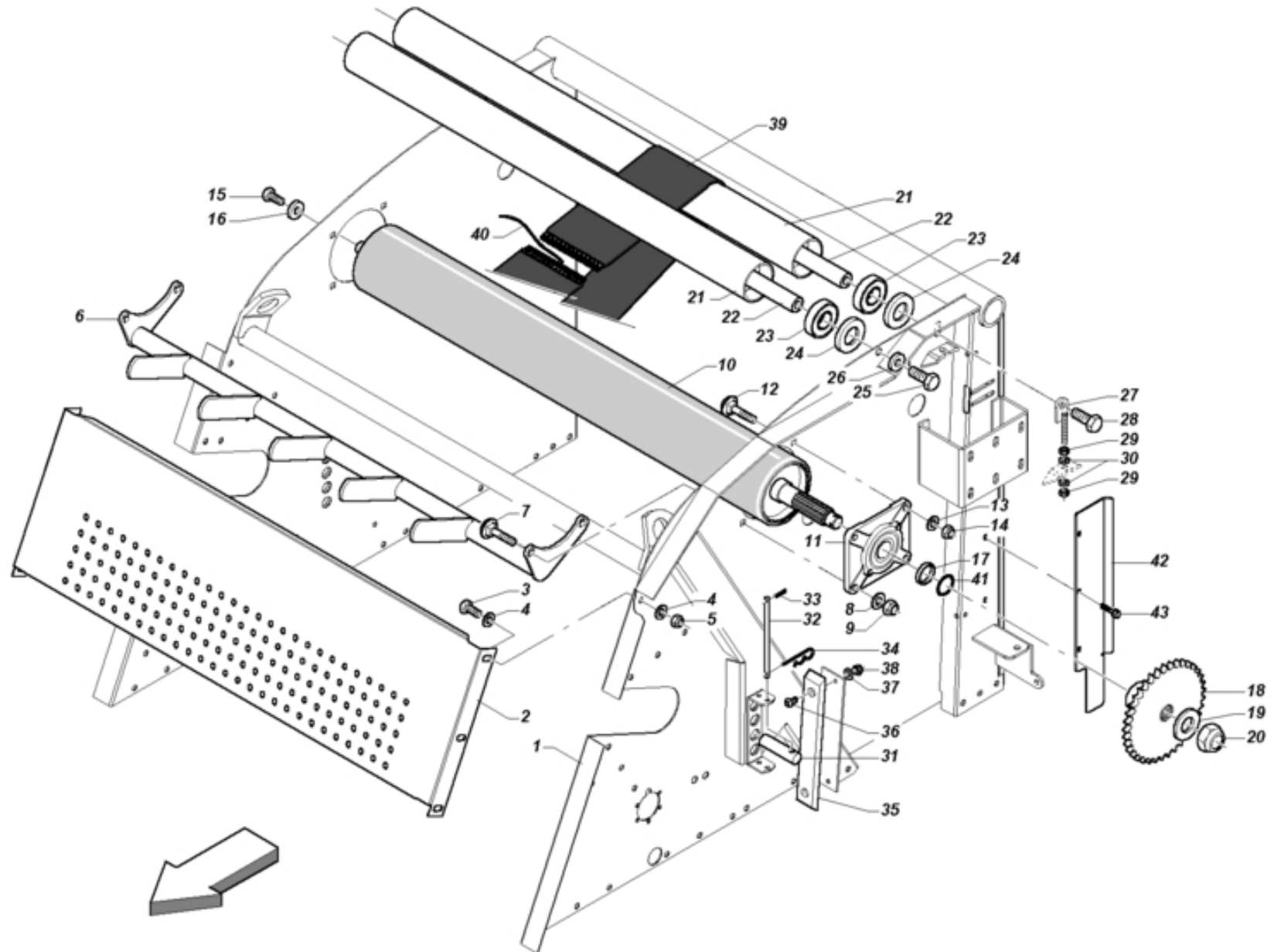

TAV_P000002_01-265

Item	Part Num.	Description	Item	Part Num.	Description
p001	7S01626	UPPER FRAME 265	p024	1300623	IDLE ROLLER LOCK
p002	C100015	FRONT CONNECTION	p025	0181635	SCREW
p003	0181230	SCREW	p026	1519319	FIFTH WHEEL
p004	1421230	WASHER	p027	7S01608	ROLLER ADJUSTER
p005	0920412	NUT	p028	0181635	SCREW
p006	7S00941	FRONT BELT GUIDE	p029	0710412	NUT
p007	0523395	SPECIAL SCREW	p030	1421230	WASHER
p008	1421230	WASHER	p031	1300647	ADJUSTMENT PIN
p009	0920412	NUT	p032	1300646	LOCK PIN
p010	3500234	RUBBER ROLLER	p033	1110325	PIN
p011	2700051	FLANGED BEARING SUPPORT FOR SPRINT	p034	1172574	PIN
p012	0523421	SPECIAL SCREW	p035	7631842	CHAIN GUIDE
p013	1421230	WASHER	p036	0470820	SCREW
p014	0920412	NUT	p037	1420820	WASHER
p015	0181635	SCREW	p038	0920208	NUT
p016	1515091	FIFTH WHEEL	p039	7600072	BELT 165
p017	1300845	SPACER	p040	7600074	BELT CONNECTING CABLE
p018	3400288	ROLLER WITH TYRES GEAR Z=25-1	p041	1300126	SHIM
p019	14R3050	WASHER	p041	1300125	SHIM (GALV)
p020	0921530	NUT	p042	C3P0038	DOOR GUARD LEFT SIDE
p021	3500172	IDLE ROLLER	p042	C3P0039	DOOR GUARD RIGHT SIDE
p022	3500214	LONG SHAFT	p043	0370615	SCREW
p023	2040002	BEARING			

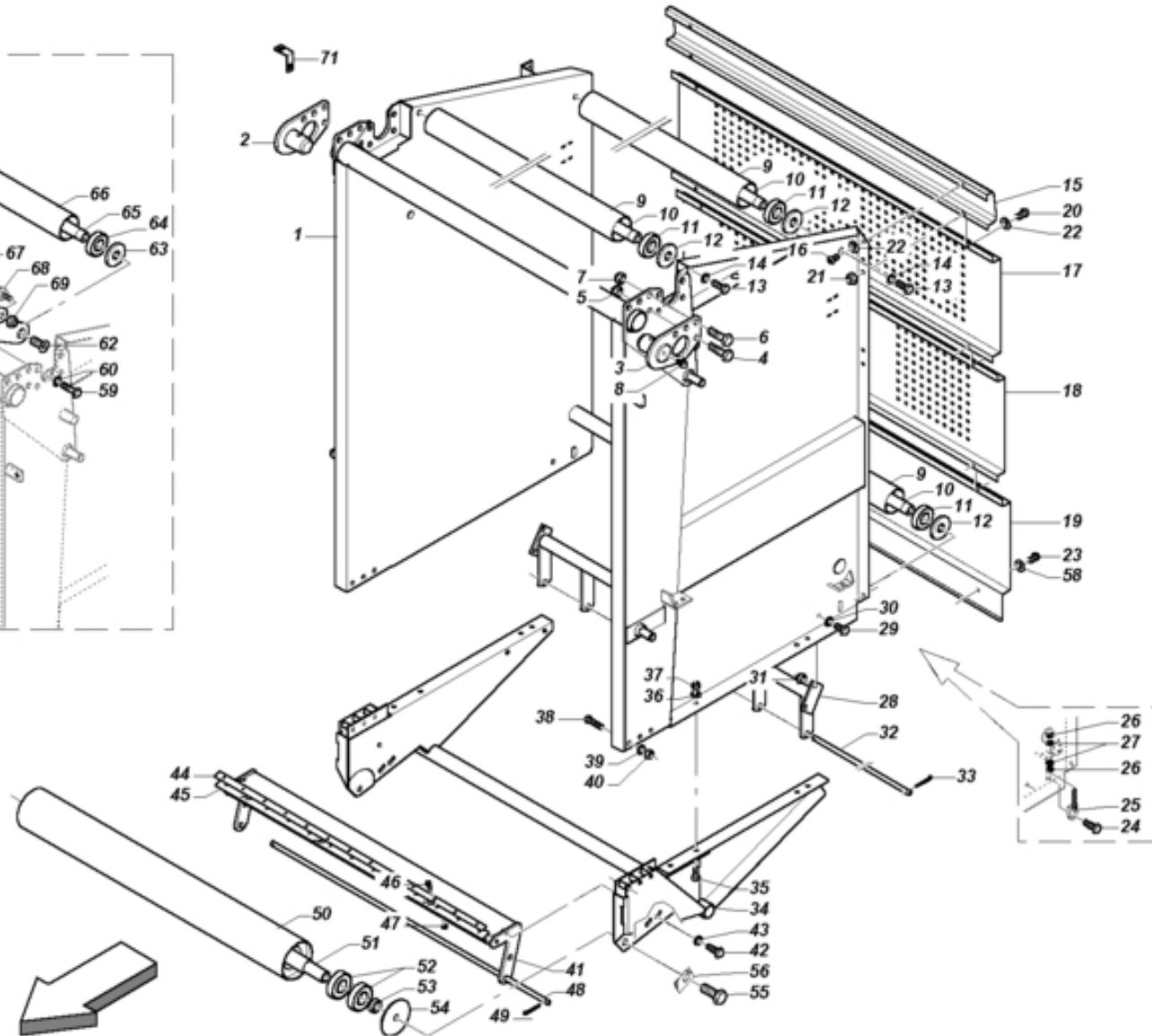
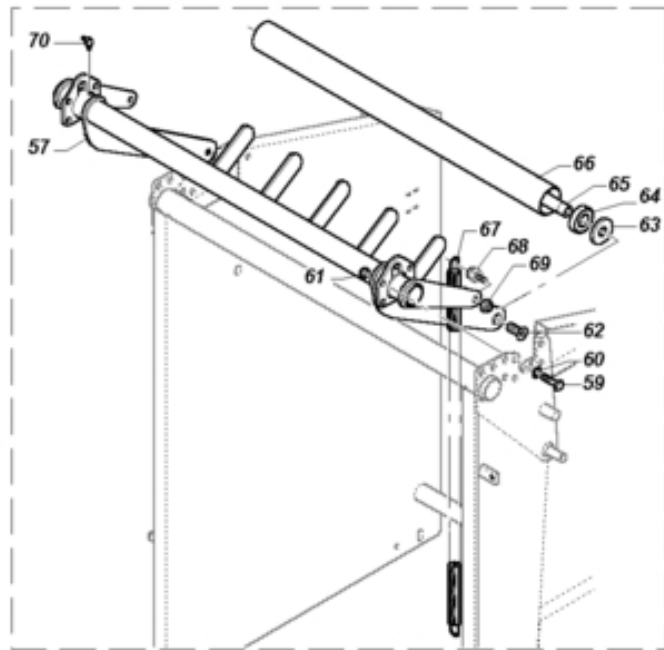

TAV_P000004_01-265

Item	Part Num.	Description	Item	Part Num.	Description
p001	7S01551	UPPER REAR GATE 265	p024	0181635	SCREW
p002	7S00932	RIGHT TAILGATE HINGE	p025	7S01608	ROLLER ADJUSTER
p003	7S00931	LEFT TAILGATE HINGE	p026	0710412	NUT
p004	0181645	SCREW	p027	1421230	WASHER
p005	0920516	NUT	p028	7S00969	REAR BELTS GUIDE
p006	0181640	SCREW	p029	0181225	SCREW
p007	0920516	NUT	p030	1421230	WASHER
p008	4221010	GREASE NIPPLE	p031	0920412	NUT
p009	3500172	IDLE ROLLER	p032	1300628	BELT GUIDE PIN
p010	3500214	LONG SHAFT	p033	1150430	GALV PIN
p011	2040002	BEARING	p034	7S01844	LOWER REAR GATE FRAME
p012	1300623	IDLE ROLLER LOCK	p035	0181230	SCREW
p013	0181635	SCREW	p036	1421230	WASHER
p014	1519319	FIFTH WHEEL	p037	0920412	NUT
p015	C100022	CAP GUARD 265	p038	0471270	SCREW
p016	0470820	SCREW	p039	1421230	WASHER
p017	C100021	MIDDLE GUARD	p040	0920412	NUT
p018	C005258	REAR GUARD FOR DECALS	p041	7S01023	TAILGATE SCRAPER
p019	C100019	LOW GUARD	p042	0181225	SCREW
p020	0471025	SCREW	p043	1531844	FIFTH WHEEL
p021	0545790	SELF-LOCKING NUT	p044	C003205	BLADE STIFFENING BAR
p022	1421025	WASHER	p045	7U00023	SCRAPER BLADE
p023	0470820	SCREW	p046	0470620	SCREW

Item	Part Num.	Description	Item	Part Num.	Description
p047	0920106	NUT	p070	4210610	GREASE NIPPLE
p048	1300628	BELT GUIDE PIN	p071	C002357	CABLE ATTACHMENT PLATE
p049	1150430	GALV PIN			
p050	7S00959	TAIL GATE IDLE ROLLER			
p051	3500237	SHORT SHAFT			
p052	2040002	BEARING			
p053	1300523	SPACER			
p054	1300590	FIFTH WHEEL			
p055	0182050	SCREW			
p056	C004148	LOCK WASHER			
p057	7S01554	II ROCKER			
p058	1430820	WASHER			
p059	0191650	SCREW			
p060	1421630	WASHER			
p061	0920516	NUT			
p062	0441635	SCREW			
p063	1300623	IDLE ROLLER LOCK			
p064	2040002	BEARING			
p065	3500213	SHORT SHAFT			
p066	3500165	IDLE ROLLER			
p067	1800037	II. BELTTENSIONER SPRING			
p068	1300937	SPRING BOLT			
p069	0920516	NUT			

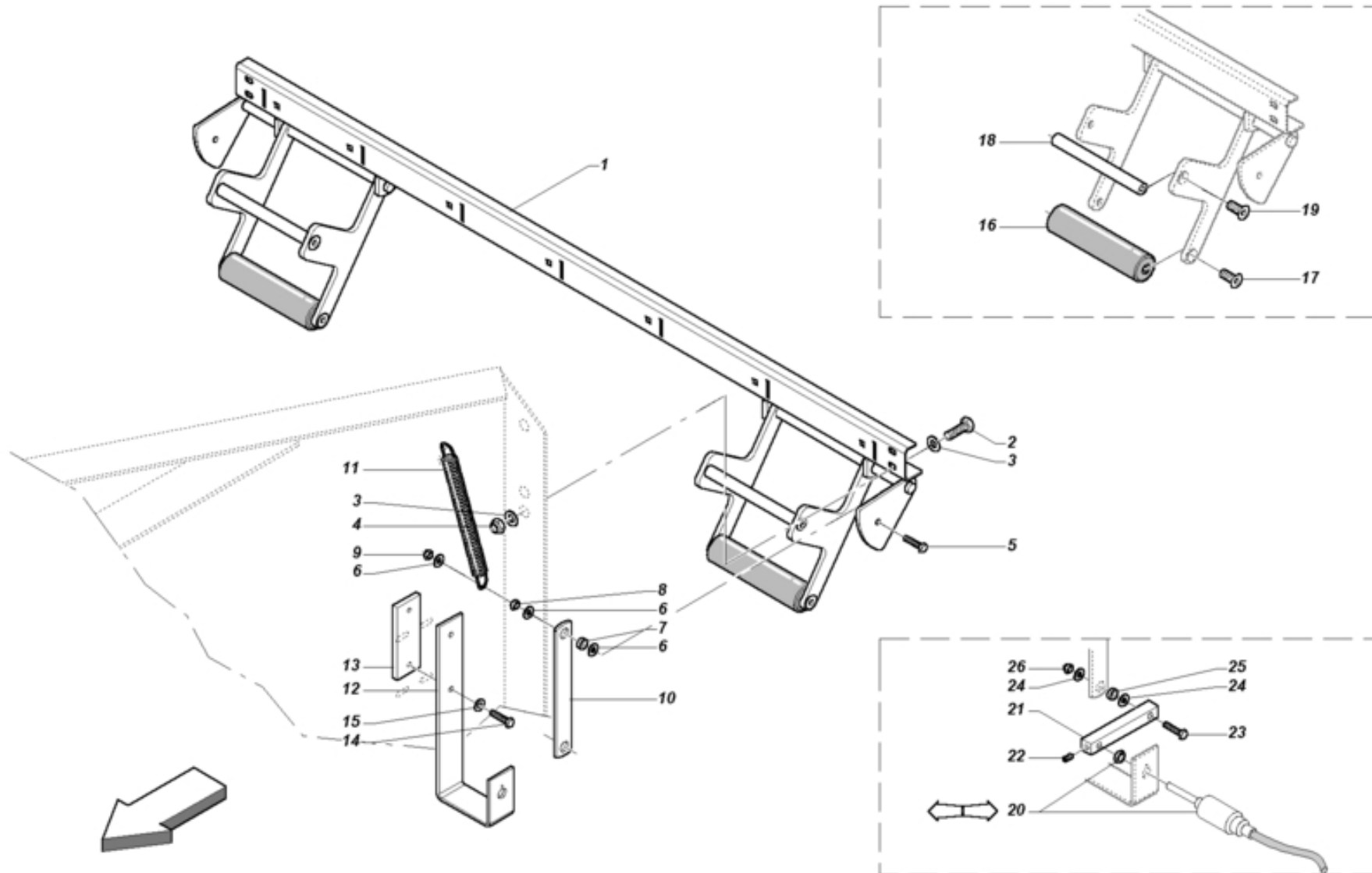

Item	Part Num.	Description	Item	Part Num.	Description
p001	7S00951	INDICATORS	p024	1430620	WASHER
p002	0181025	SCREW	p025	1300866	BUSH
p003	1421025	WASHER	p026	0920106	NUT
p004	0545790	SELF-LOCKING NUT			
p005	0180640	SCREW			
p006	1430620	WASHER			
p007	1300866	BUSH			
p008	0710106	NUT			
p009	0920106	NUT			
p010	C004227	SENSOR SHIFTING PLATE			
p011	1810409	SPRING			
p012	C004231	POTENZIOMETER ATTACHMENT			
p013	C004008	LIMIT SWITCH PLATE			
p014	0180516	SCREW			
p015	1430520	WASHER			
p016	7M00276	INDICATOR ROLLER			
p017	0440820	SCREW			
p018	3500024	CONNECTION			
p019	0440820	SCREW			
p020	E000128	ENCODER EXTREME LOADING			
p021	C004228	PLATE			
p022	0430610	SCREW			
p023	0180630	SCREW			

TAV_P000006_01

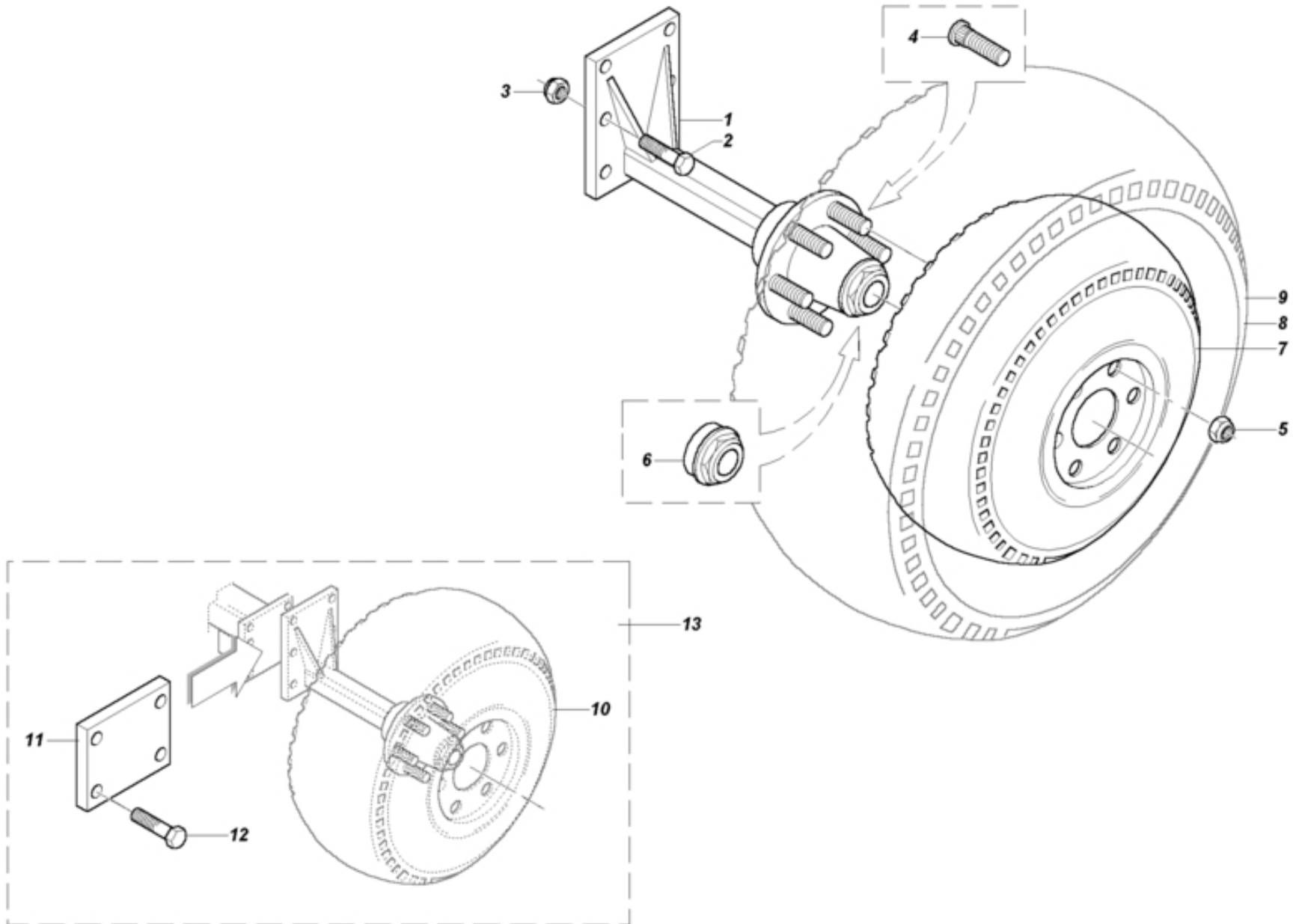

Item	Part Num.	Description	
p001	7100026	HUB WITH STUB AXLE	
p002	0192070	SCREW	
p003	0920620	NUT	
p004	R000273	WHEEL STUD BOLT M18X1,5	
p005	0821318	NUT	
p006	7100050	CAP	
p007	7100022	COMPLETE WHEEL	
p008	7100013	COMPLETE WHEEL 11,5/80-15,3	
p009	7100039	COMPLETE WHEEL	
p010	7100041	COMPLETE TYRE	
p011	C003765	SHIM PLATE	
p012	0192090	SCREW	
p013	ZAP2042		

TAV_P000009_00-1

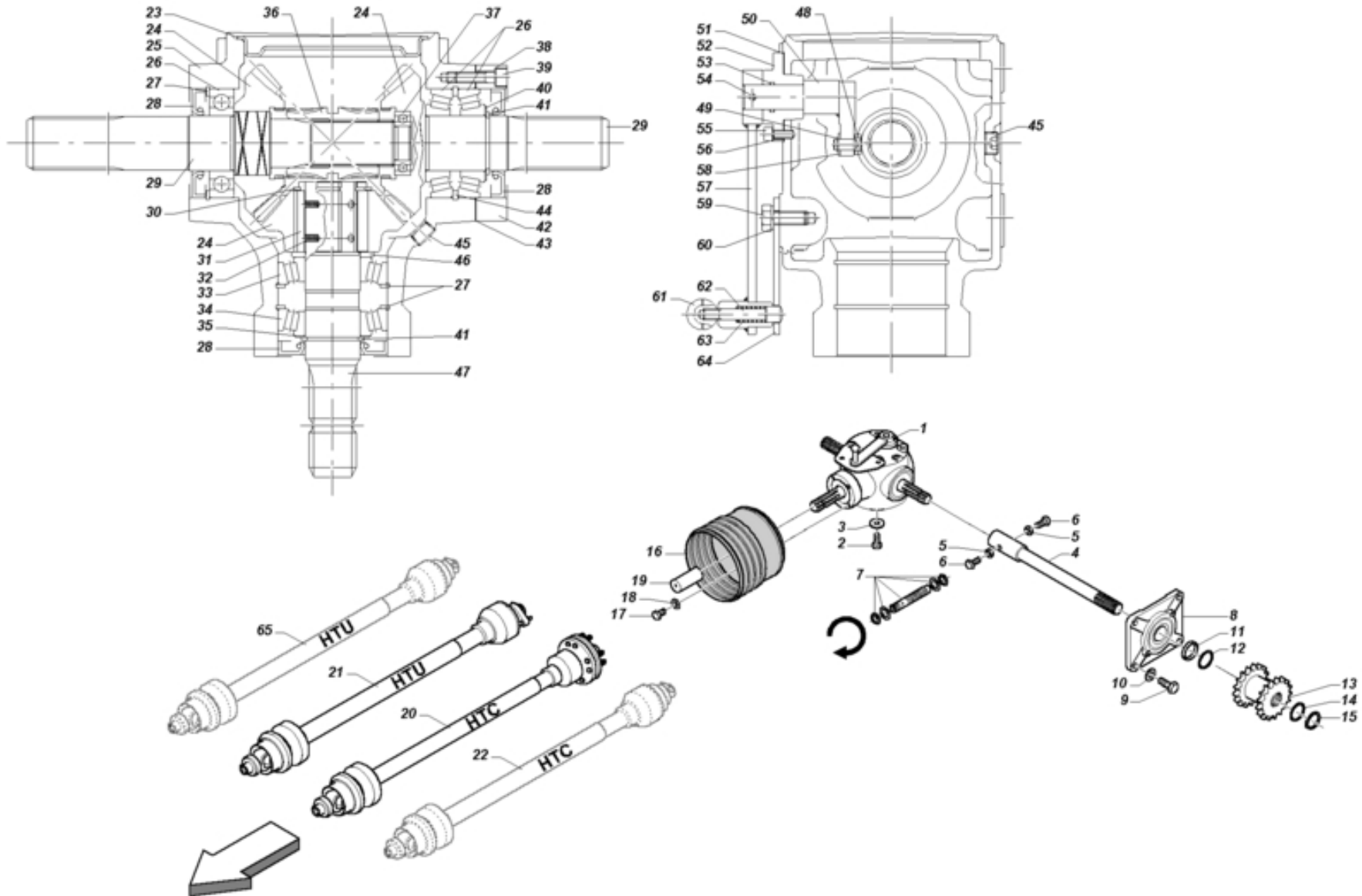

TAV_P000009_00-1

Item	Part Num.	Description	Item	Part Num.	Description
p001	3900179	GEAR BOX	p020	3600076	PTO SHAFT
p002	0181430	SCREW	p021	3600087	PTO SHAFT
p003	1516040	FIFTH WHEEL	p022	3600092	PTO SHAFT
p004	R000304	EXTENSION SHAFT L=602	p023	R000288	COVER D=145
p005	0710106	NUT	p024	R000303	BEVEL GEAR TRIAL R=1.1
p006	0180625	SCREW	p025	R000277	BOX 2070
p007	E000056	PROXIMITY SENSOR	p026	R000958	BEARING CONICAL ROLLER BEARING
p008	2700051	FLANGED BEARING SUPPORT FOR SPRINT	p027	R000256	ELASTIC RING 80-I (SP=2,5)
p009	0181235	SCREW	p028	4303460	SEAL
p010	1421230	WASHER	p029	R000316	'XY' AXLE SHAFT
p011	1329469	SPACER	p030	R000298	RETAINING RING 50-E (SP=2,0)
p012	1300151	SHIM	p031	R000289	RL PLATE
p012	1300126	SHIM	p032	R000089	SPRING
p012	1300125	SHIM (GALV)	p033	2124024	BEARING
p013	3400224	DOUBLE GEAR Z=12/12-1"	p034	2004018	BEARING
p014	1300126	SHIM	p035	R000261	SHIM RING 40,2X54,8X0,1
p014	1300125	SHIM (GALV)	p035	R000258	SHIM RING 40,2X54,8X0,2
p014	1300151	SHIM	p035	R000259	SHIM RING 40,2X54,8X0,3
p015	1700040	SEEGER RING	p035	R000260	SHIM RING 40,2X54,8X0,4
p016	7V00076	COMPLETE COUNTER-HOUSING	p036	R000276	COUPLING FOR DISENGAGEMENT
p017	0181015	SCREW	p037	2003013	BEARING
p018	1421025	WASHER	p038	R000296	LOCK WASHER D=8 SCHNORR
p019	4417079	SLEEVE	p039	0400830	SCREW

TAV_P000009_00-1

Item	Part Num.	Description	Item	Part Num.	Description
p040	R000261	SHIM RING 40,2X54,8X0,1	p060	R000294	SPRING WASHER D=12 DIN128B
p040	R000258	SHIM RING 40,2X54,8X0,2	p061	R000302	BALL HANDLE
p040	R000259	SHIM RING 40,2X54,8X0,3	p062	R000291	PIN
p040	R000260	SHIM RING 40,2X54,8X0,4	p063	R000301	SPRING DM 9,81X1,2X25
p041	R000257	ELASTIC RING 40-E(SP=2,5)	p064	R000281	SELECTOR DISENGAGEMENT
p042	R000286	RING-HOLDER SPACER	p065	3600093	PTO SHAFT
p043	R000287	PACKING 80X115X0,3			
p044	R000299	RETAINING RING 80-I (SP=4,0)			
p045	R000175	PLUG			
p046	R000285	SPACER			
p047	R000278	AXIS SHAFT			
p048	R000290	SLIDING BLOCK			
p049	R000297	RETAINING RING 8-E (SP=0,8)			
p050	R000282	LEVER RELEASE			
p051	R000284	PACKING 35X65X0,2			
p052	R000283	LEVER SUPPORT			
p053	R000300	OR RING 123			
p054	1110540	PIN			
p055	R000292	SCREW TCEI M 6X 16-12.9			
p056	R000295	LOCK WASHER D=6 SCHNORR			
p057	R000280	REVERSER EXTERNAL LEVER			
p058	R000293	PLAIN WASHER D=8 UNI6592			
p059	0181225	SCREW			

TAV_P000125_00

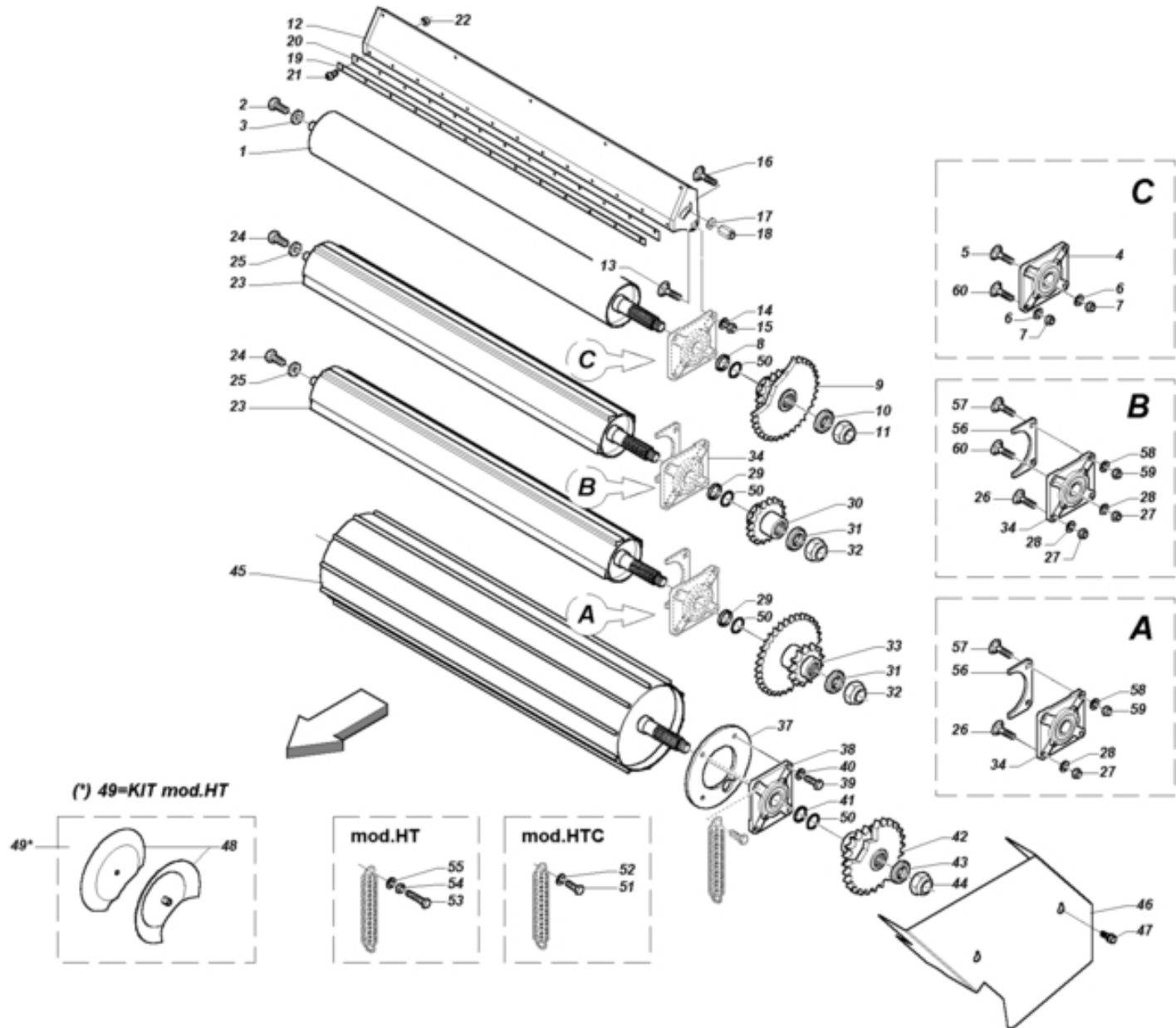

TAV_P000125_00

Item	Part Num.	Description	Item	Part Num.	Description
p001	7S00942	LOWER MOTOR ROLLER	p024	0181635	SCREW
p002	0181635	SCREW	p025	1515091	FIFTH WHEEL
p003	1515091	FIFTH WHEEL	p026	0523421	SPECIAL SCREW
p004	2700051	FLANGED BEARING SUPPORT FOR SPRINTE	p027	1421230	WASHER
p005	0523421	SPECIAL SCREW	p028	0920412	NUT
p006	1421230	WASHER	p029	1300845	SPACER
p007	0920412	NUT	p030	3400235	GEAR Z=11-1"
p008	1300845	SPACER	p031	14R3050	WASHER
p009	3400287	SMOOTH ROLLER GEAR Z=23-10/1"	p032	0921530	NUT
p010	14R3050	WASHER	p033	34P0006	LOWER GEAR ROLLER Z=23-12/1"
p011	0921530	NUT	p034	2700051	FLANGED BEARING SUPPORT FOR SPRINTE
p012	7S01387	SCRAPER	p037	C003056	ROLLER INNER PLATE
p013	0523395	SPECIAL SCREW	p038	2700106	THREADED FLANGED SUPPORT
p014	1421230	WASHER	p039	0181235	SCREW
p015	0920412	NUT	p040	1421230	WASHER
p016	0523421	SPECIAL SCREW	p041	1300151	SHIM
p017	1421230	WASHER	p042	3400290	BIG ROLLER GEAR Z=16-24/1"
p018	C003634	COLUMN	p043	14R3050	WASHER
p019	C003205	BLADE STIFFENING BAR	p044	0921530	NUT
p020	7U00023	SCRAPER BLADE	p045	7S01841	BIG ROLLER
p021	0470620	SCREW	p046	C3P0001	GUARD
p022	0920106	NUT	p047	0370001	SCREW
p023	7S01822	ROLLER NEW	p048	7S01845	CHAMBER TIGHTENING CUPS

Item	Part Num.	Description	
p049	ZVRP0001		
p050	1300125	SHIM (GALV)	
p050	1300126	SHIM	
p051	0471235	SCREW	
p052	1431225	WASHER	
p053	0181260	SCREW	
p054	1421230	WASHER	
p055	0920412	NUT	
p056	C6P0003	ROLLERS GUARD	
p057	0523395	SPECIAL SCREW	
p058	1421230	WASHER	
p059	0920412	NUT	
p060	05C0002		

TAV_P000007_02

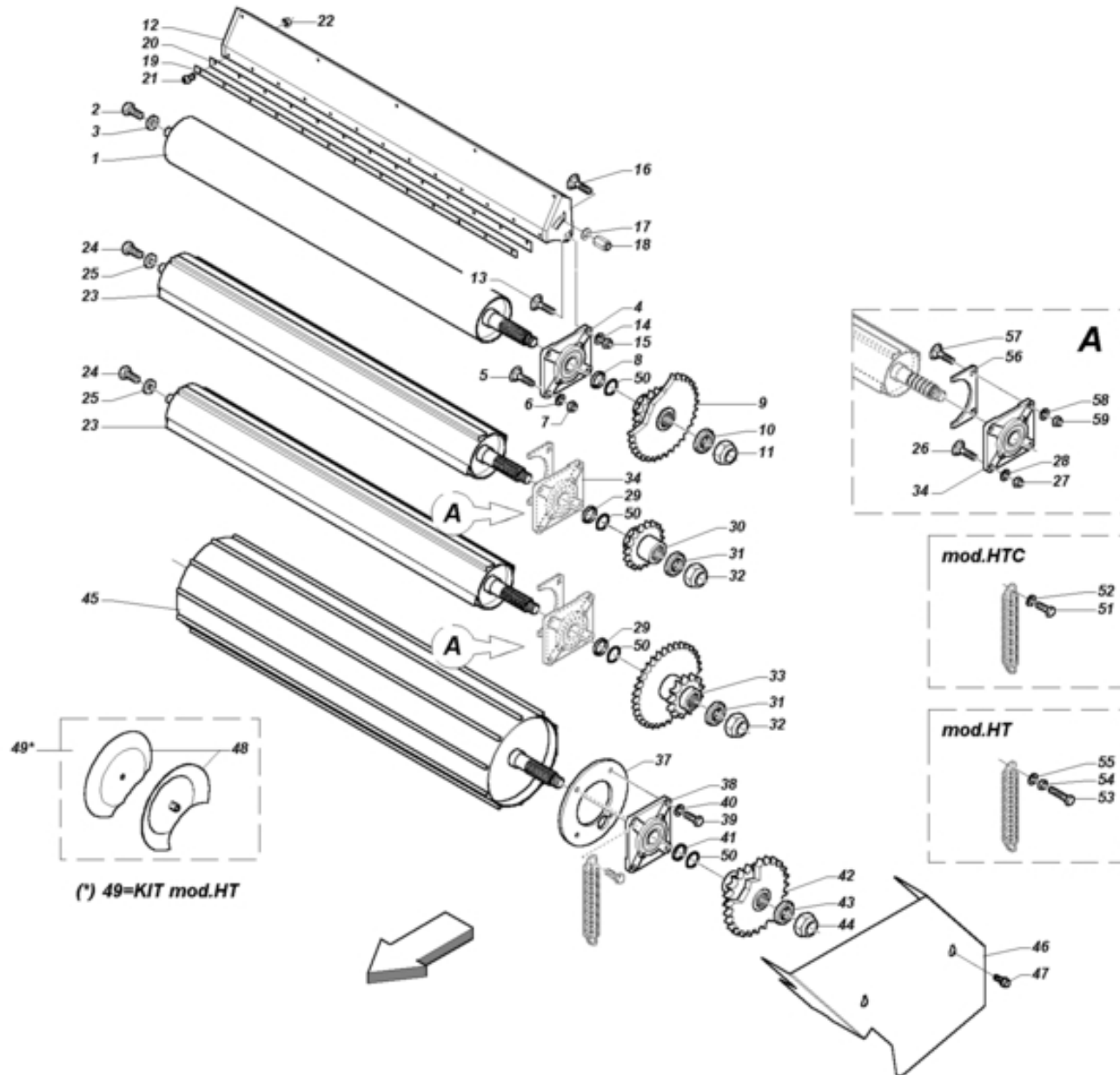

TAV_P000007_02

Item	Part Num.	Description	Item	Part Num.	Description
p001	7S00942	LOWER MOTOR ROLLER	p024	0181635	SCREW
p002	0181635	SCREW	p025	1515091	FIFTH WHEEL
p003	1515091	FIFTH WHEEL	p026	0523421	SPECIAL SCREW
p004	2700051	FLANGED BEARING SUPPORT FOR SPRINT	p027	1421230	WASHER
p005	0523421	SPECIAL SCREW	p028	0920412	NUT
p006	1421230	WASHER	p029	1300845	SPACER
p007	0920412	NUT	p030	3400235	GEAR Z=11-1"
p008	1300845	SPACER	p031	14R3050	WASHER
p009	3400287	SMOOTH ROLLER GEAR Z=23-10/1"	p032	0921530	NUT
p010	14R3050	WASHER	p033	34P0006	LOWER GEAR ROLLER Z=23-12/1"
p011	0921530	NUT	p034	2700051	FLANGED BEARING SUPPORT FOR SPRINT
p012	7S01387	SCRAPER	p037	C003056	ROLLER INNER PLATE
p013	0523395	SPECIAL SCREW	p038	2700106	THREADED FLANGED SUPPORT
p014	1421230	WASHER	p039	0181235	SCREW
p015	0920412	NUT	p040	1421230	WASHER
p016	0523421	SPECIAL SCREW	p041	1300151	SHIM
p017	1421230	WASHER	p042	3400290	BIG ROLLER GEAR Z=16-24/1"
p018	C003634	COLUMN	p043	14R3050	WASHER
p019	C003205	BLADE STIFFENING BAR	p044	0921530	NUT
p020	7U00023	SCRAPER BLADE	p045	7S01841	BIG ROLLER
p021	0470620	SCREW	p046	C3P0001	GUARD
p022	0920106	NUT	p047	0370001	SCREW
p023	7S01822	ROLLER NEW	p048	7S01845	CHAMBER TIGHTENING CUPS



TAV_P000007_02

Item	Part Num.	Description	
p049	ZVRP0001		
p050	1300126	SHIM	
p050	1300125	SHIM (GALV)	
p051	0471235	SCREW	
p052	1431225	WASHER	
p053	0181260	SCREW	
p054	1421230	WASHER	
p055	0920412	NUT	
p056	C6P0003	ROLLERS GUARD	
p057	0523395	SPECIAL SCREW	
p058	1421230	WASHER	
p059	0920412	NUT	

TAV_P000010_01-265

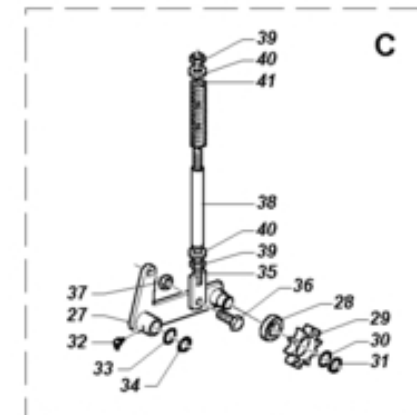
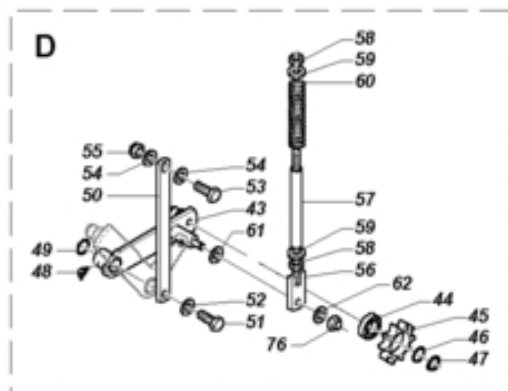
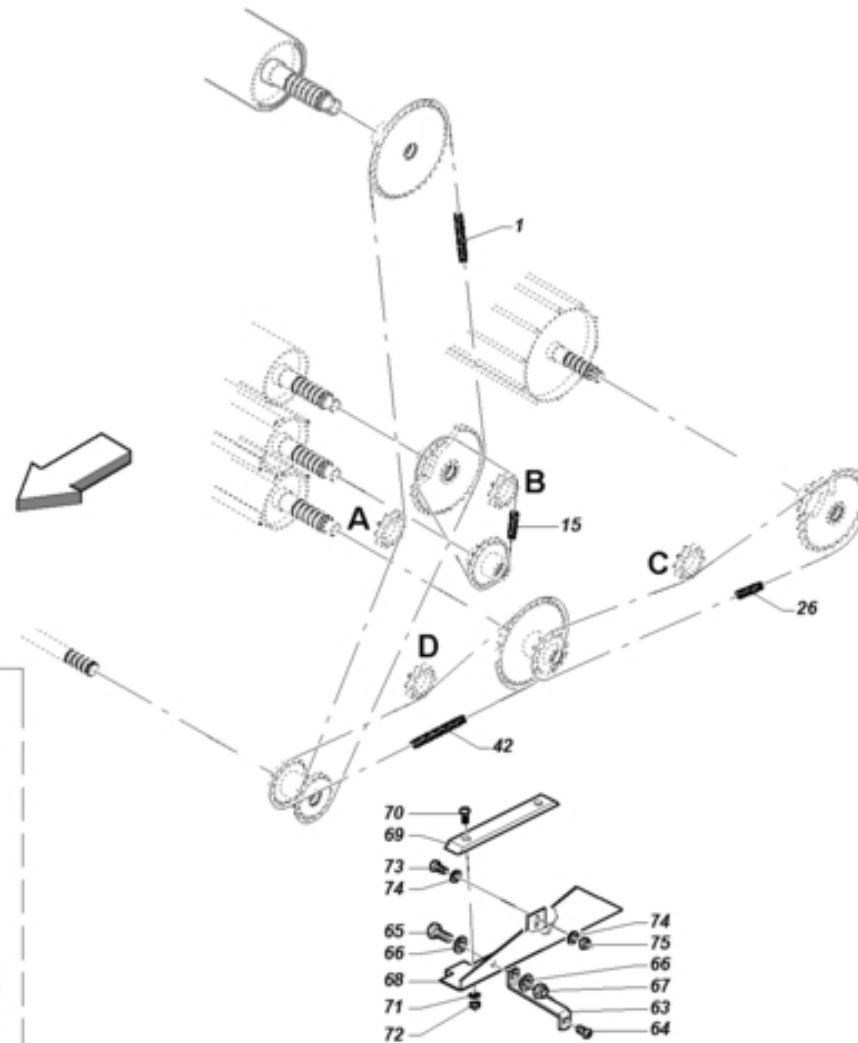
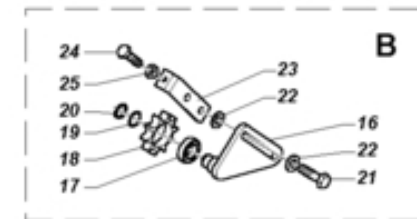
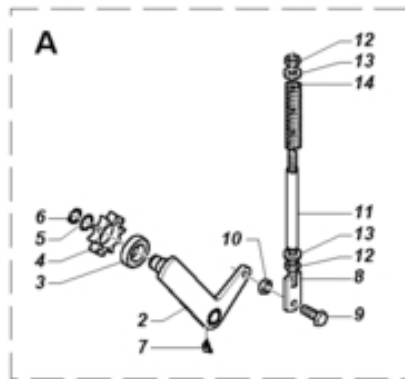

Item	Part Num.	Description	Item	Part Num.	Description
p001	30E1149	ROLLER CHAIN	p019	1300105	SHIM
p001	30E0017	SPRING JOINT	p019	1300102	SHIM
p002	7S00953	RIGHT TENSIONER ROD	p020	1700025	SEEGER RING
p003	2042515	BEARING	p021	0191250	SCREW
p004	3400274	SPROCKET Z=10-1"	p022	1516038	FIFTH WHEEL
p005	1300104	SHIM	p023	C003605	FEEDER CONNECTING ROD
p005	1300105	SHIM	p024	0181250	SCREW
p005	1300102	SHIM	p025	0710412	NUT
p006	1700025	SEEGER RING	p026	30E0017	SPRING JOINT
p007	4210610	GREASE NIPPLE	p026	30E1056	ROLLER CHAIN
p008	7S01441	TIGHTENING PULLEY ROD M16	p027	7S00953	RIGHT TENSIONER ROD
p009	0181230	SCREW	p028	2042515	BEARING
p010	0710412	NUT	p029	3400274	SPROCKET Z=10-1"
p011	1300157	SPACER	p030	1300105	SHIM
p012	0710516	NUT	p030	1300104	SHIM
p013	1519319	FIFTH WHEEL	p030	1300102	SHIM
p014	1800046	SPRING	p031	1700025	SEEGER RING
p015	30E1027	ROLLER CHAIN	p032	4210610	GREASE NIPPLE
p015	30E0017	SPRING JOINT	p033	1300159	SHIM (GALV)
p016	7S00958	TIE ROD	p033	1300105	SHIM
p017	2042515	BEARING	p034	1700025	SEEGER RING
p018	3400274	SPROCKET Z=10-1"	p035	7S01441	TIGHTENING PULLEY ROD M16
p019	1300104	SHIM	p036	0181230	SCREW

TAV_P000010_01-265

Item	Part Num.	Description	Item	Part Num.	Description
p037	0710412	NUT	p056	7S01758	TIE ROD
p038	1300157	SPACER	p057	1300157	SPACER
p039	0710516	NUT	p058	0710516	NUT
p040	1519319	FIFTH WHEEL	p059	1519319	FIFTH WHEEL
p041	1800046	SPRING	p060	1800046	SPRING
p042	30E0017	SPRING JOINT	p061	1421230	WASHER
p042	30E1079	ROLLER CHAIN	p062	1700012	SEEGER RING
p043	7S01759	TENSIONER	p063	C005427	GUARD FEEDER LEFT SIDE SUPPORT
p044	2042515	BEARING	p064	04N0820	SCREW
p045	3400274	SPROCKET Z=10-1"	p065	0181230	SCREW
p046	1300105	SHIM	p066	1421230	WASHER
p046	1300104	SHIM	p067	0920412	NUT
p046	1300102	SHIM	p068	C004908	GUARD
p047	1700025	SEEGER RING	p069	7631842	CHAIN GUIDE
p048	4210610	GREASE NIPPLE	p070	0470820	SCREW
p049	1300159	SHIM (GALV)	p071	1420820	WASHER
p049	1300105	SHIM	p072	0920208	NUT
p050	C003057	TIGHTENER CONNECTION	p073	0181025	SCREW
p051	0181225	SCREW	p074	1421025	WASHER
p052	1421230	WASHER	p075	0545790	SELF-LOCKING NUT
p053	0181230	SCREW	p076	0920412	NUT
p054	1421230	WASHER			
p055	0920412	NUT			

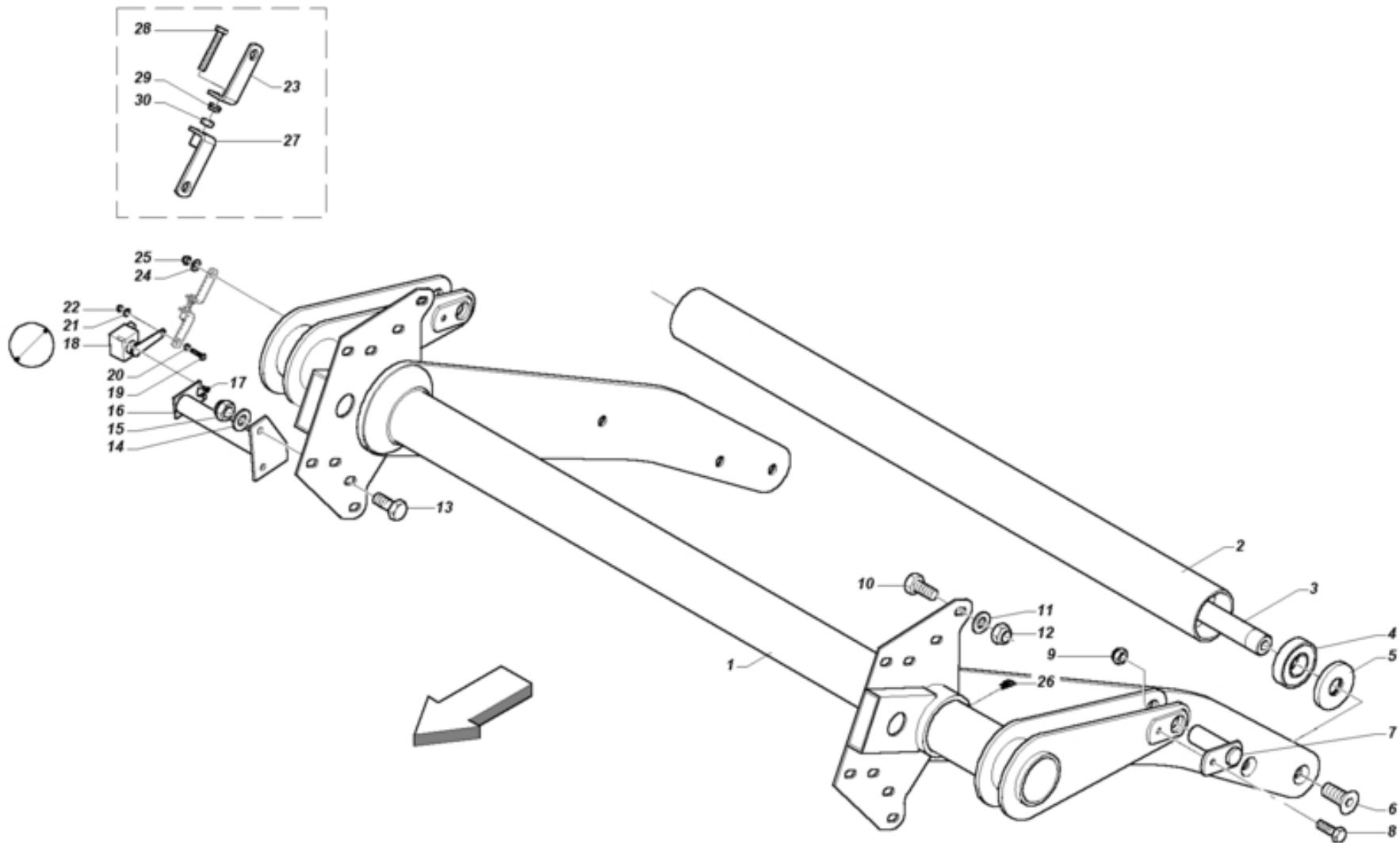

TAV_P000011_01-265

Item	Part Num.	Description	Item	Part Num.	Description
p001	7S01630	BELT TENSIONER ARM 265	p024	1430820	WASHER
p002	3500165	IDLE ROLLER	p025	0920208	NUT
p003	3500213	SHORT SHAFT	p026	4211010	GREASE NIPPLE
p004	2040002	BEARING	p027	7MP0014	ADJSUTMENT BASE
p005	1300623	IDLE ROLLER LOCK	p028	0180640	SCREW
p006	0441635	SCREW	p029	0920106	NUT
p007	7S00936	JACK PIN	p030	0710106	NUT
p008	0190830	SCREW			
p009	0920208	NUT			
p010	0181230	SCREW			
p011	1421230	WASHER			
p012	0920412	NUT			
p013	0181235	SCREW			
p014	1421230	WASHER			
p015	0920412	NUT			
p016	7S01471	POTENTIOMETER SUPPORT			
p017	0440510	SCREW			
p018	E000130	ENCODER DIMENSION BALER			
p019	0180620	SCREW			
p020	1300866	BUSH			
p021	1430620	WASHER			
p022	0920106	NUT			
p023	C6P0052	ADJUSTMENT BASE			

TAV_P000014_02-3

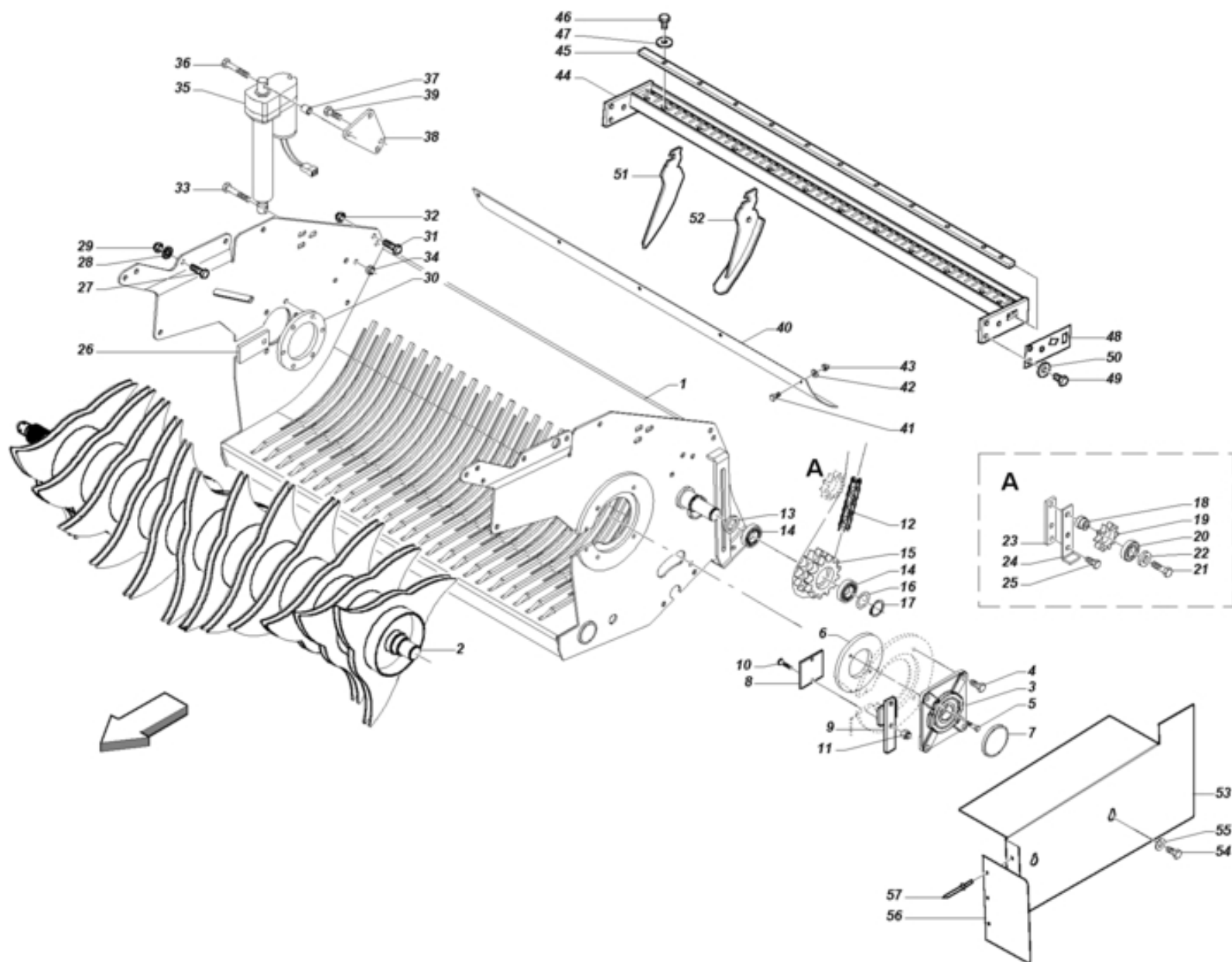

TAV_P000014_02-3

Item	Part Num.	Description	Item	Part Num.	Description
p001	7S01791	NEW TOPCUT FRAME	p022	1518412	FIFTH WHEEL
p002	7S01944	ROTOR WITH 3 POINTED DISCS HTC	p023	C002390	LOCK
p003	2700153	FLANGED CUT ROTOR SUPPORT	p024	C002389	REGISTER
p004	0181230	SCREW	p025	0181230	SCREW
p005	1420820	WASHER	p026	C003748	RIGHT SLOT COMPENSATION
p005	0190850	SCREW	p027	0181230	SCREW
p006	1300714	IDLE SUPPORT COUNTERFLANGE	p028	1421230	WASHER
p007	4400001	CAP	p029	0920412	NUT
p008	C003746	LEFT SLOT COMPENSATION	p030	1300509	MOTOR SUPPORT COUNTERFLANGE
p009	7SP0046	LEFT SIDE SHIM LOCK	p031	0181240	SCREW
p010	0440835	SCREW	p032	0920412	NUT
p011	0920208	NUT	p033	0181260	SCREW
p012	30E0017	SPRING JOINT	p034	0920412	NUT
p012	30E1039	ROLLER CHAIN	p035	E000064	ACTUATOR WARNER D12 21B5 04
p013	1330957	SPACER	p036	0181290	SCREW
p014	2043514	BEARING	p037	1300746	SPACER
p015	3400005	SPROCKET Z-12/12 1"	p038	7S01203	ACTUATOR ATTACHMENT
p016	1534416	SHIM	p039	0401235	SCREW
p017	1700035	SEEGER RING	p040	7V00092	KNIFE SPRING PROTECTION
p018	1300302	PIN	p041	0180820	SCREW
p019	3400274	SPROCKET Z=10-1"	p042	14B0825	
p020	2042515	BEARING	p043	0920208	NUT
p021	0191260	SCREW	p044	7S01801	CROSS BAR

Item	Part Num.	Description	
p045	C005018	SUPPORT ROD	
p046	0181020	SCREW	
p047	1421025	WASHER	
p048	C003616	SCRAPER CROSS MEMBER SHIM	
p049	0181225	SCREW	
p050	1515797	FIFTH WHEEL	
p051	C003977	DETACHABLE SCRAPER	
p052	7S01800	SCRAPER AND SLIDING BLOCK	
p053	C005268	CUT GUARD	
p054	0180820	SCREW	
p055	1420820	WASHER	
p056	C004239	CUT GUARD EXTENSION	
p057	1000009	RIVET	

TAV_P000015_01

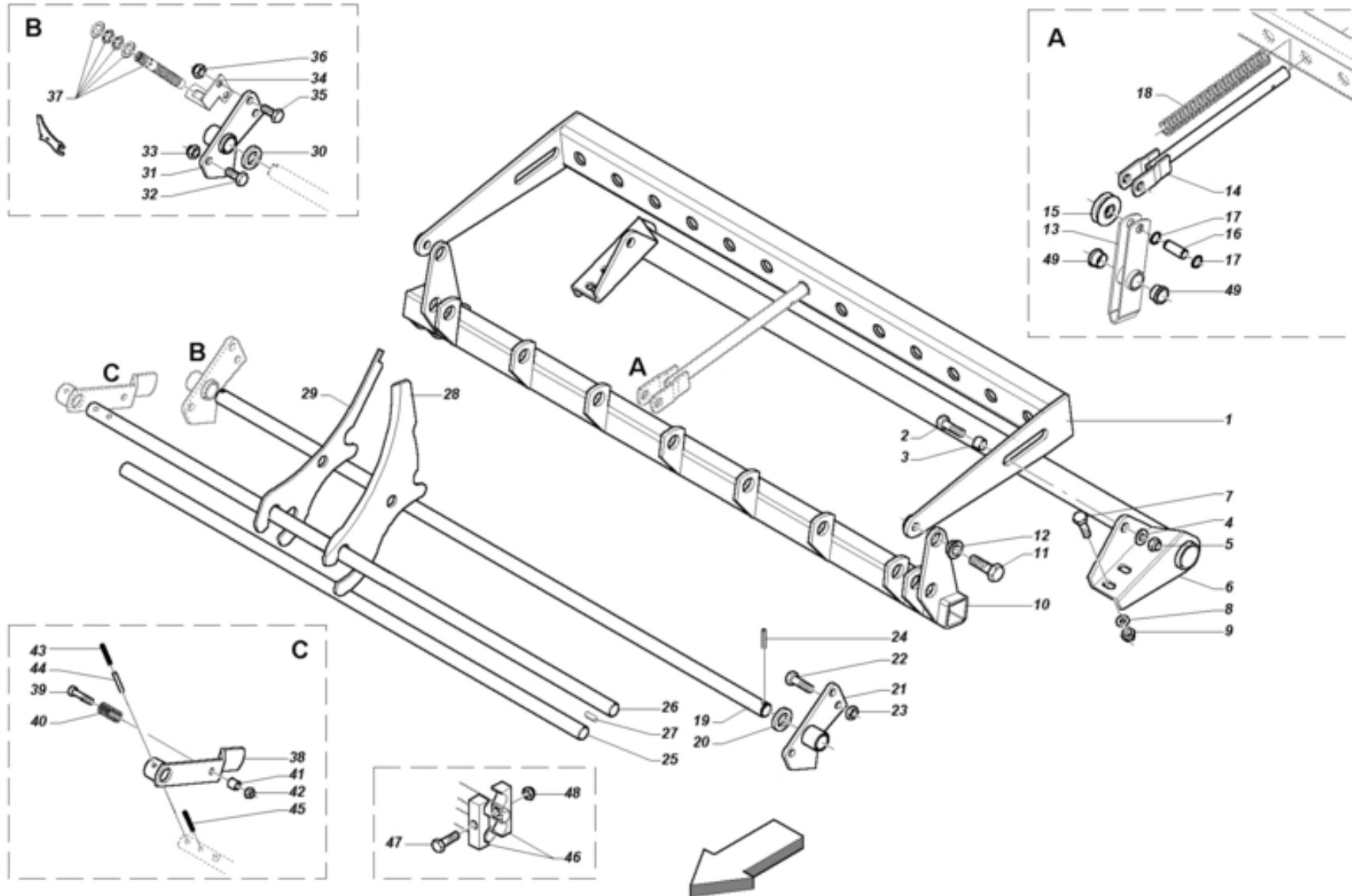

TAV_P000015_01

Item	Part Num.	Description	Item	Part Num.	Description
p001	7S01802	KNIFE RESISTANCE TOPCUT	p024	1110635	PIN
p002	0181645	SCREW	p025	35P0016	NEW ROD
p003	1300745	SPACER	p026	35P0015	NEW KNIVES FULCRUM
p004	1421630	WASHER	p027	1203025	TANG
p005	0920516	NUT	p028	7U00035	SPECIAL TOPCUT KNIFE
p006	7S01636	LOWER CONNECTION	p029	ZAP2006	13 BLANK KNIVES KIT
p007	0181225	SCREW	p030	1300036	FIFTH WHEEL
p008	1421230	WASHER	p031	7S01144	RIGHT LINKAGE FULCRUM
p009	0920412	NUT	p032	0181230	SCREW
p010	7S01803	KNIFE CONTROL TOPCUT	p033	0920412	NUT
p011	0181630	SCREW	p034	C004233	"CUT"SENSOR SUPPORT
p012	1300706	GUIDE BUSH	p035	0181235	SCREW
p013	7SP0024	TOPCUT ROCKER ARM	p036	0920412	NUT
p014	7S01125	SPRING BRAKET	p037	E000056	PROXIMITY SENSOR
p015	3800014	KNIVES GUIDE PULLEY	p038	7S01159	SAFETY HANDLE
p016	1300694	KNIFE ROLLER PIN	p039	0401060	SCREW
p017	1700016	SEEGER RING	p040	1821993	SPRING
p018	1800049	SPRING	p041	1300401	PIN WITHOUT NET
p019	3500034	PIVOT	p042	0545790	SELF-LOCKING NUT
p020	1300036	FIFTH WHEEL	p043	1110840	PIN
p021	7S01145	LEFT LINKAGE FULCRUM	p044	1110540	PIN
p022	0181230	SCREW	p045	1110840	PIN
p023	0920412	NUT	p046	27P0001	DRIVE HALF ROD



TAV_P000015_01

Item	Part Num.	Description	
p047	0191265	SCREW	
p048	0920412	NUT	
p049	25P0003	NYLON BUSH	

TAV_P000016_02

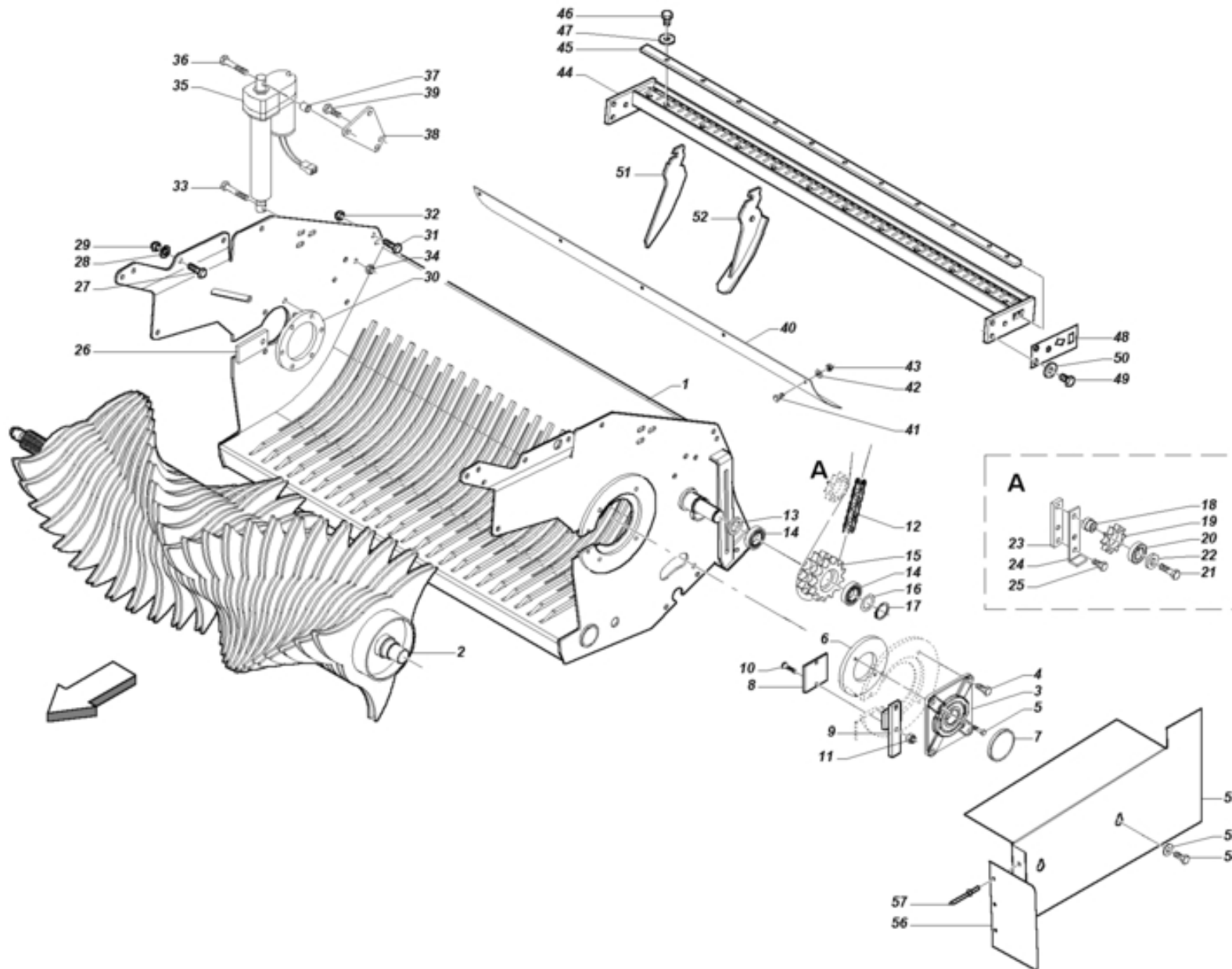

TAV_P000016_02

Item	Part Num.	Description	Item	Part Num.	Description
p001	7S01792	NEW ULTRACUT FRAME	p022	1518412	FIFTH WHEEL
p002	7S01127	ULTRACUT ROTOR	p023	C002390	LOCK
p003	2700153	FLANGED CUT ROTOR SUPPORT	p024	C002389	REGISTER
p004	0181230	SCREW	p025	0181230	SCREW
p005	1420820	WASHER	p026	C003748	RIGHT SLOT COMPENSATION
p005	0190850	SCREW	p027	0181230	SCREW
p006	1300714	IDLE SUPPORT COUNTERFLANGE	p028	1421230	WASHER
p007	4400001	CAP	p029	0920412	NUT
p008	C003746	LEFT SLOT COMPENSATION	p030	1300509	MOTOR SUPPORT COUNTERFLANGE
p009	7SP0046	LEFT SIDE SHIM LOCK	p031	0181240	SCREW
p010	0440835	SCREW	p032	0920412	NUT
p011	0920208	NUT	p033	0181260	SCREW
p012	30E0017	SPRING JOINT	p034	0920412	NUT
p012	30E1039	ROLLER CHAIN	p035	E000064	ACTUATOR WARNER D12 21B5 04
p013	1330957	SPACER	p036	0181290	SCREW
p014	2043514	BEARING	p037	1300746	SPACER
p015	3400005	SPROCKET Z-12/12 1"	p038	7S01203	ACTUATOR ATTACHMENT
p016	1534416	SHIM	p039	0401235	SCREW
p017	1700035	SEEGER RING	p040	7V00092	KNIFE SPRING PROTECTION
p018	1300302	PIN	p041	0180820	SCREW
p019	3400274	SPROCKET Z= 10-1"	p042	1430820	WASHER
p020	2042515	BEARING	p043	0920208	NUT
p021	0191260	SCREW	p044	7S01847	CROSS BAR

Item	Part Num.	Description	
p045	C003981	LINK STUD	
p046	0181020	SCREW	
p047	1421025	WASHER	
p048	C003616	SCRAPER CROSS MEMBER SHIM	
p049	0181225	SCREW	
p050	1515797	FIFTH WHEEL	
p051	C003977	DETACHABLE SCRAPER	
p052	7S01800	SCRAPER AND SLIDING BLOCK	
p053	C005268	CUT GUARD	
p054	0180820	SCREW	
p055	1420820	WASHER	
p056	C004239	CUT GUARD EXTENSION	
p057	1000009	RIVET	

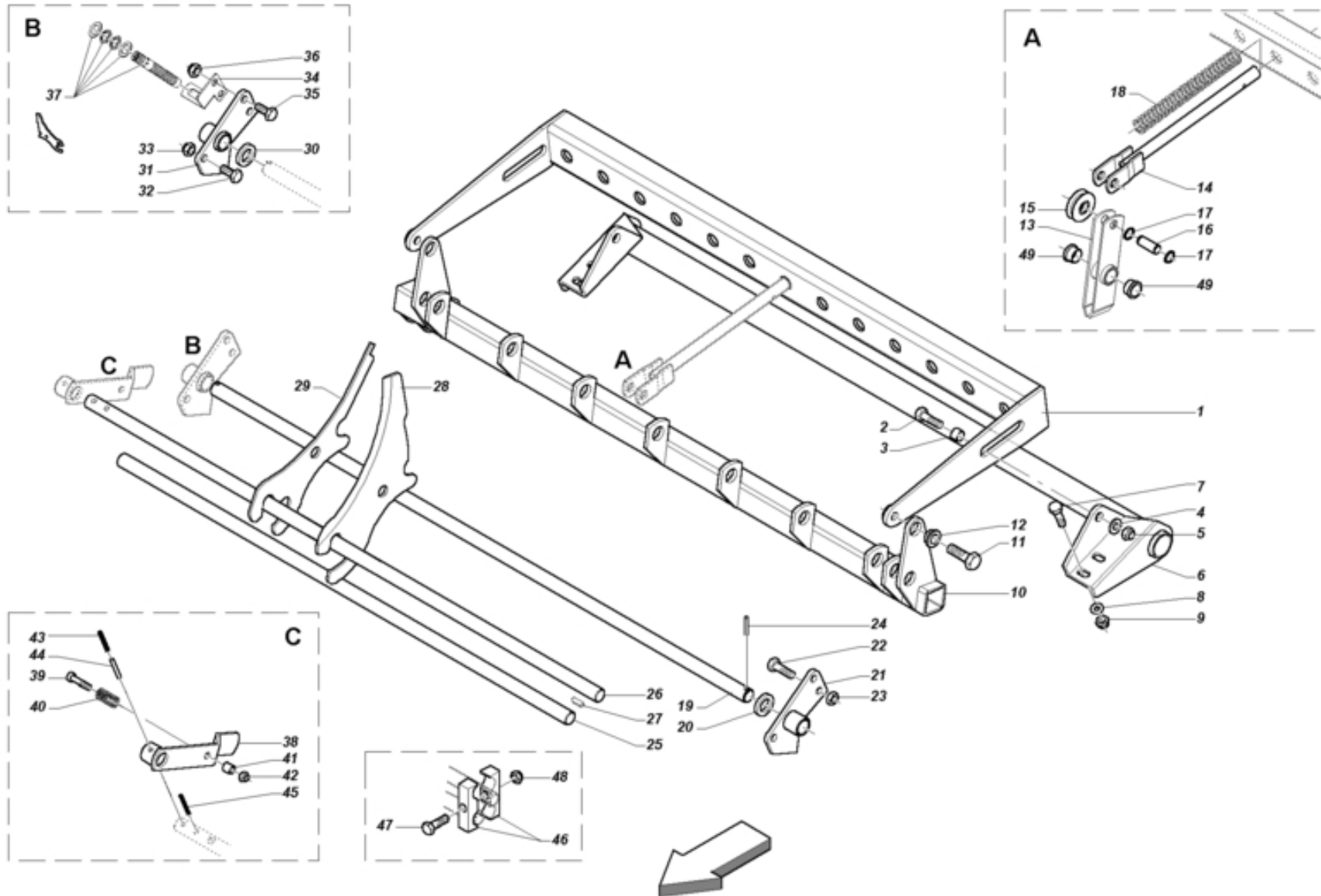

TAV_P000017_01

Item	Part Num.	Description	Item	Part Num.	Description
p001	7S01142	KNIFE RESISTANCE (ULTRACUT)	p024	1110635	PIN
p002	0181645	SCREW	p025	35P0016	NEW ROD
p003	1300745	SPACER	p026	35P0015	NEW KNIVES FULCRUM
p004	1421630	WASHER	p027	1203025	TANG
p005	0920516	NUT	p028	7U00035	SPECIAL TOPCUT KNIFE
p006	7S01636	LOWER CONNECTION	p029	ZAP2007	25 BLANK KNIVES KIT
p007	0181225	SCREW	p030	1300036	FIFTH WHEEL
p008	1421230	WASHER	p031	7S01144	RIGHT LINKAGE FULCRUM
p009	0920412	NUT	p032	0181230	SCREW
p010	7S01143	KNIFE CONTROL	p033	0920412	NUT
p011	0181630	SCREW	p034	C004233	"CUT"SENSOR SUPPORT
p012	1300706	GUIDE BUSH	p035	0181235	SCREW
p013	7SP0048	NEW ROCKER ARM	p036	0920412	NUT
p014	7S01125	SPRING BRAKET	p037	E000056	PROXIMITY SENSOR
p015	3800014	KNIVES GUIDE PULLEY	p038	7S01159	SAFETY HANDLE
p016	1300694	KNIFE ROLLER PIN	p039	0401060	SCREW
p017	1700016	SEEGER RING	p040	1821993	SPRING
p018	1800049	SPRING	p041	1300401	PIN WITHOUT NET
p019	3500034	PIVOT	p042	0545790	SELF-LOCKING NUT
p020	1300036	FIFTH WHEEL	p043	1110840	PIN
p021	7S01145	LEFT LINKAGE FULCRUM	p044	1110540	PIN
p022	0181230	SCREW	p045	1110840	PIN
p023	0920412	NUT	p046	27P0001	DRIVE HALF ROD



TAV_P000017_01

Item	Part Num.	Description	
p047	0191265	SCREW	
p048	0920412	NUT	
p049	25P0003	NYLON BUSH	

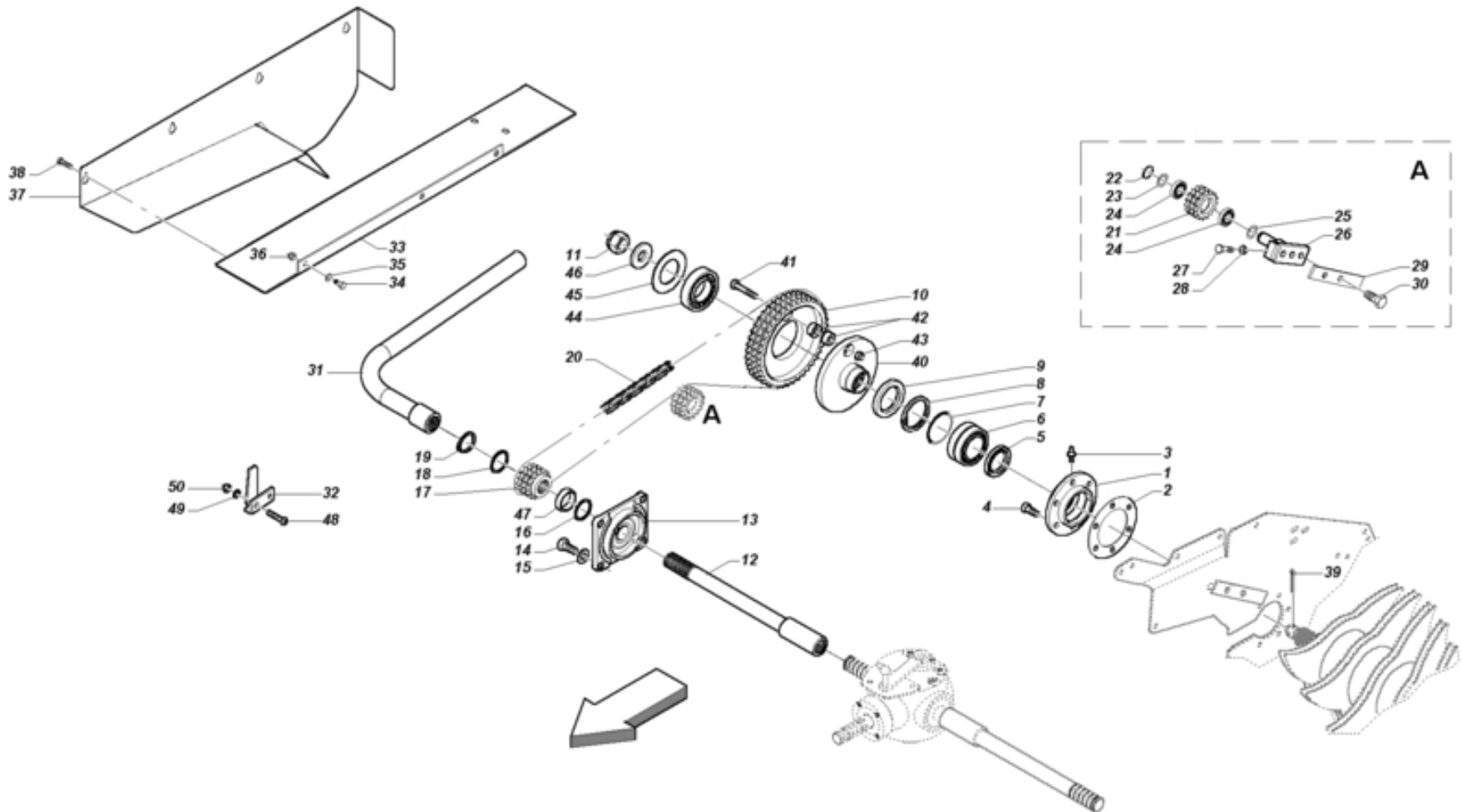

TAV_P000026_01

Item	Part Num.	Description	Item	Part Num.	Description
p001	2700052	CONTROL ROTOR SUPPORT	p021	3400073	TRIPLE GEAR Z=13-3/4"X7/16
p002	1300960	ROTOR SUPPORT SPACING	p022	1700025	SEEGER RING
p003	4200610	GREASE NIPPLE	p023	1300105	SHIM
p004	0401240	SCREW	p023	1300106	SHIM (GALV)
p005	4304966	SEAL	p024	2042512	BEARING
p006	2335023	BEARING	p025	1300106	SHIM (GALV)
p007	1534318	SHIM	p025	1300105	SHIM
p008	1710090	SEEGER RING	p026	7S00848	TENSIONER PIN
p009	4305668	SEAL	p027	0181280	SCREW
p010	3400070	TRIPLE GEAR Z=42-3/4"X7/16"	p028	0710412	NUT
p011	0851530	NUT	p029	C002732	REINFORCEMENT
p012	R000304	EXTENSION SHAFT L=602	p030	0181635	SCREW
p013	2700051	FLANGED BEARING SUPPORT FOR SPRINT	p031	7S01804	HANDLE
p014	0181235	SCREW	p032	C005030	HANDLE SUPPORT
p015	1421230	WASHER	p033	C002663	COVER PLATE ATTACHMENT
p016	1300150	SHIM (GALV)	p034	0181225	SCREW
p016	1300151	SHIM	p035	1421230	WASHER
p017	3400072	TRIPLE GEAR Z=13-3/4"X7/16"	p036	0920412	NUT
p018	1300151	SHIM	p037	7S01212	ROTOR TRANSMISSION COVER
p018	1300150	SHIM (GALV)	p038	0180815	SCREW
p019	1700040	SEEGER RING	p039	1150560	GALV PIN
p020	30F0017	SPRING JOINT	p040	2700079	ROTOR SAFETY
p020	30F1117	ROLLER CHAIN	p041	0191460	SCREW

Item	Part Num.	Description	
p042	1300702	BUSH	
p043	0920514	NUT	
p044	2047020	BEARING	
p045	1300824	FLANGE	
p046	1300823	FITH WHEEL	
p047	1300355	SPACER	
p048	0471280	SCREW	
p049	1421230	WASHER	
p050	0920412	NUT	

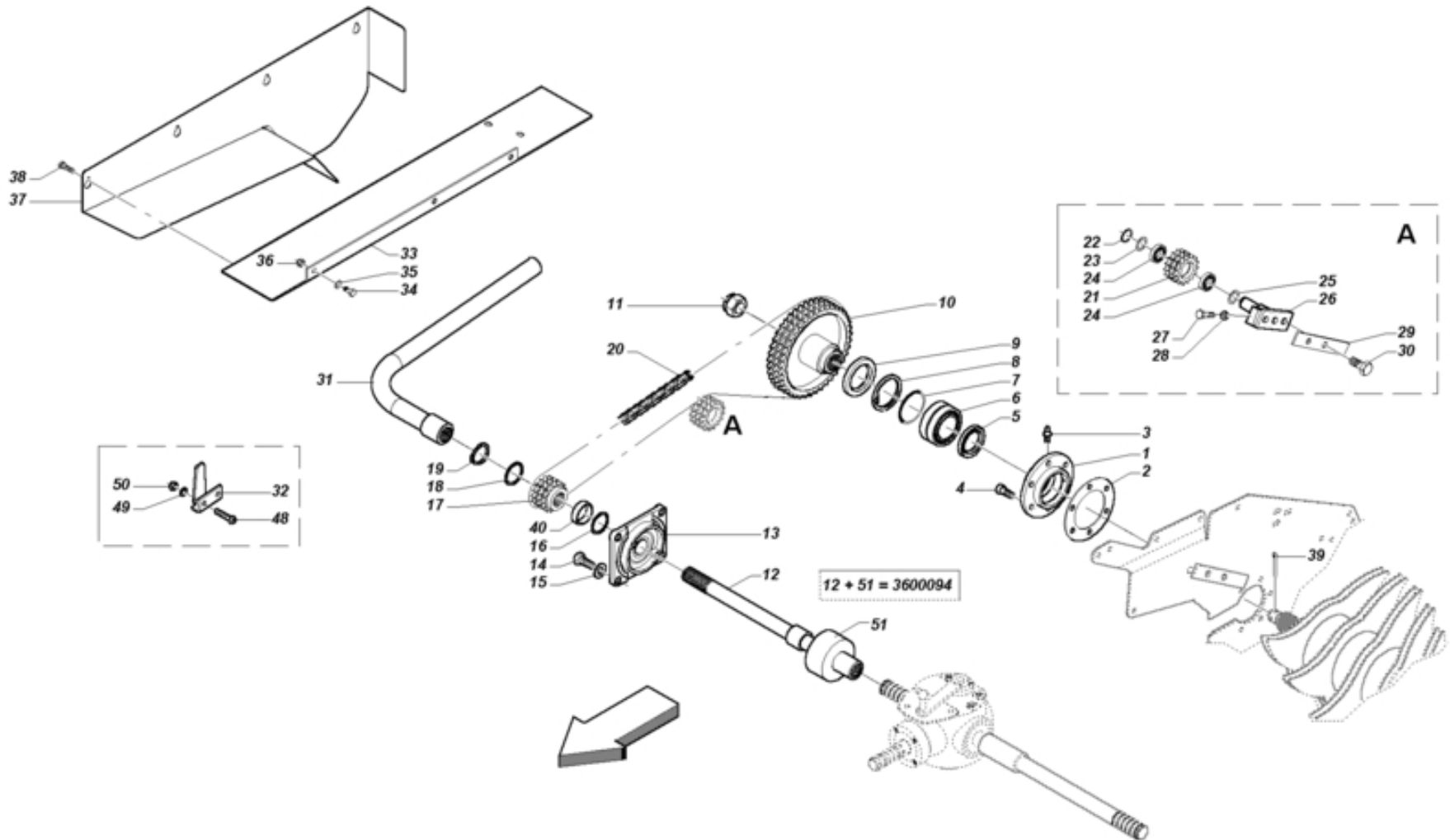

TAV_P000027_01

Item	Part Num.	Description	Item	Part Num.	Description
p001	2700052	CONTROL ROTOR SUPPORT	p021	3400073	TRIPLE GEAR Z=13-3/4"X7/16
p002	1300960	ROTOR SUPPORT SPACING	p022	1700025	SEEGER RING
p003	4200610	GREASE NIPPLE	p023	1300106	SHIM (GALV)
p004	0401240	SCREW	p023	1300105	SHIM
p005	4304966	SEAL	p024	2042512	BEARING
p006	2335023	BEARING	p025	1300105	SHIM
p007	1534318	SHIM	p025	1300106	SHIM (GALV)
p008	1710090	SEEGER RING	p026	7S00848	TENSIONER PIN
p009	4305668	SEAL	p027	0181280	SCREW
p010	7S01609	ROTOR SPROCKET	p028	0710412	NUT
p011	0851530	NUT	p029	C002732	REINFORCEMENT
p012	3600127		p030	0181635	SCREW
p013	2700051	FLANGED BEARING SUPPORT FOR SPRINT	p031	7S01804	HANDLE
p014	0181235	SCREW	p032	C005030	HANDLE SUPPORT
p015	1421230	WASHER	p033	C002663	COVER PLATE ATTACHMENT
p016	1300150	SHIM (GALV)	p034	0181225	SCREW
p016	1300151	SHIM	p035	1421230	WASHER
p017	3400072	TRIPLE GEAR Z=13-3/4"X7/16"	p036	0920412	NUT
p018	1300150	SHIM (GALV)	p037	7S01212	ROTOR TRANSMISSION COVER
p018	1300151	SHIM	p038	0370001	SCREW
p019	1700040	SEEGER RING	p039	1150560	GALV PIN
p020	30F0017	SPRING JOINT	p040	1300355	SPACER
p020	30F1117	ROLLER CHAIN	p048	0471280	SCREW



TAV_P000027_01

Item	Part Num.	Description	
p049	1421230	WASHER	
p050	0920412	NUT	
p051	3600128		

TAV_P000019_01

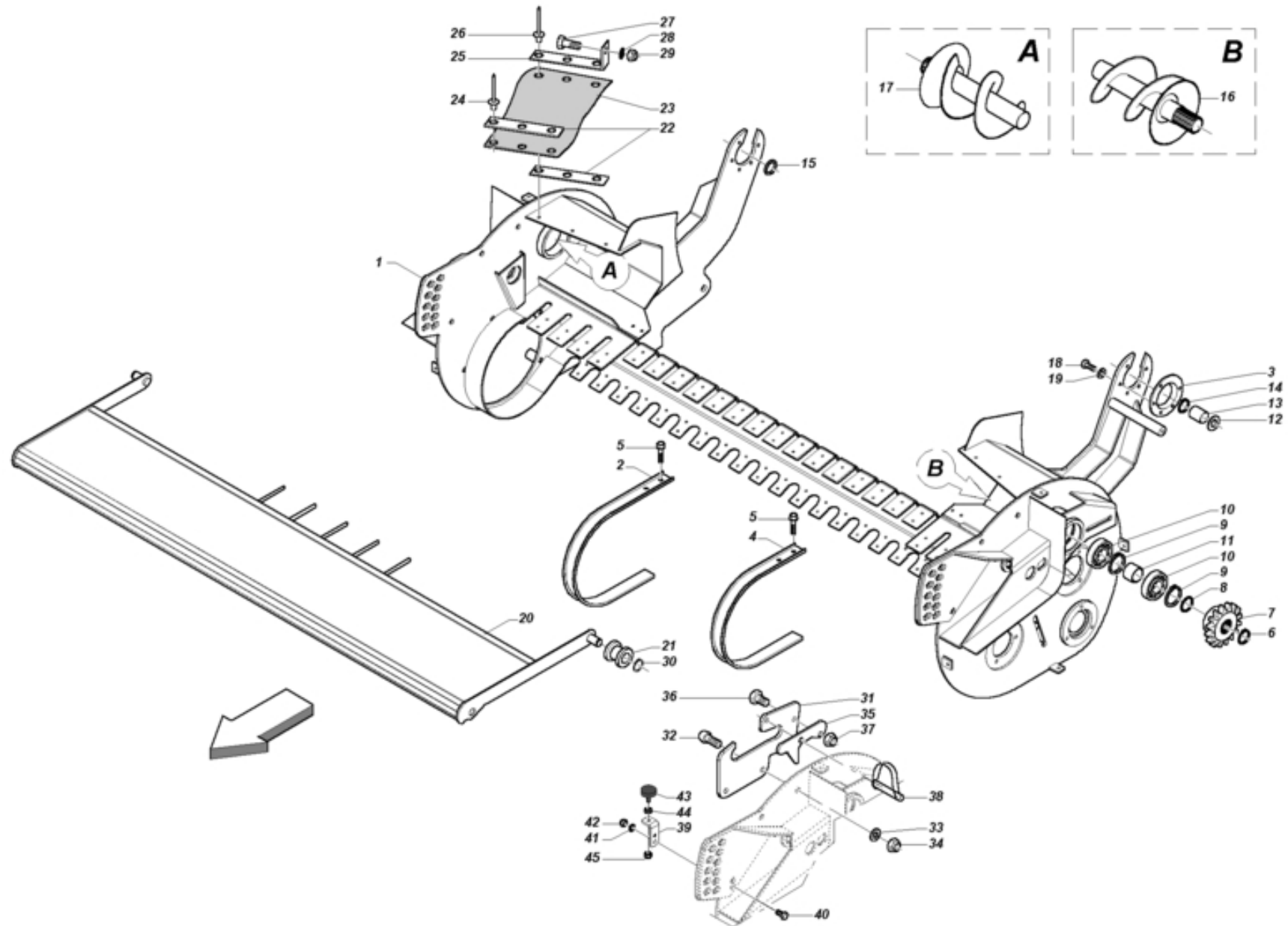

TAV_P000019_01

Item	Part Num.	Description	Item	Part Num.	Description
p001	7S01645	PICK-UP FRAME (CUT)	p020	7S01848	WIDE PICK-UP BAFFLE PLATE
p001	7S01650	PICK-UP FRAME (CUT)	p020	7S01849	BAFFLE PLATE
p002	C003304	PICK-UP CENTRAL	p021	C003712	BUSH
p003	1300649	FLANGE	p022	C003730	FIXING PLATE
p004	C003183	LATERAL BAND	p022	C002410	FIXING PLATE
p005	0370615	SCREW	p023	7V00074	AUGER PROTECTION
p006	1700035	SEEGER RING	p023	7V00081	AUGER GUARD
p007	3400270	GEAR Z=16 3/4"	p024	1000013	RIVET
p008	1534416	SHIM	p025	C002409	RUBBER SUPPORT
p009	1710080	SEEGER RING	p025	C003729	RUBBER SUPPORT
p010	2040002	BEARING	p026	1000012	RIVET
p011	1300739	SPACER	p027	0181025	SCREW
p012	1547230	SHIM	p028	1421025	WASHER
p012	1527654	FIFTH WHEEL	p029	0545790	SELF-LOCKING NUT
p013	2500010	BUSHING	p030	1700025	SEEGER RING
p014	1700045	SEEGER RING	p031	C100017	CONVEYOR PLATE ATTACHMENT
p015	1300003	PU FIFTH WHEEL	p032	0471230	SCREW
p016	7S01652	LEFT PICK-UP AUGER 200	p033	1421230	WASHER
p016	7S01654	LEFT PICK-UP AUGER 220	p034	0920412	NUT
p017	7S01651	RIGHT PICK-UP AUGER 200	p035	C004002	HOOK
p017	7S01653	RIGHT PICK-UP AUGER 220	p036	0181230	SCREW
p018	0181025	SCREW	p037	0920412	NUT
p019	1421025	WASHER	p038	1000021	PIN

TAV_P000019_01

Item	Part Num.	Description	
p039	C005187	PLUG ATTACHMENT	
p040	0181030	SCREW	
p041	1421025	WASHER	
p042	0545790	SELF-LOCKING NUT	
p043	7049749	BUMPER 50X21 M10	
p044	0710310	NUT	
p045	0545790	SELF-LOCKING NUT	

TAV_P000020_00-1-M

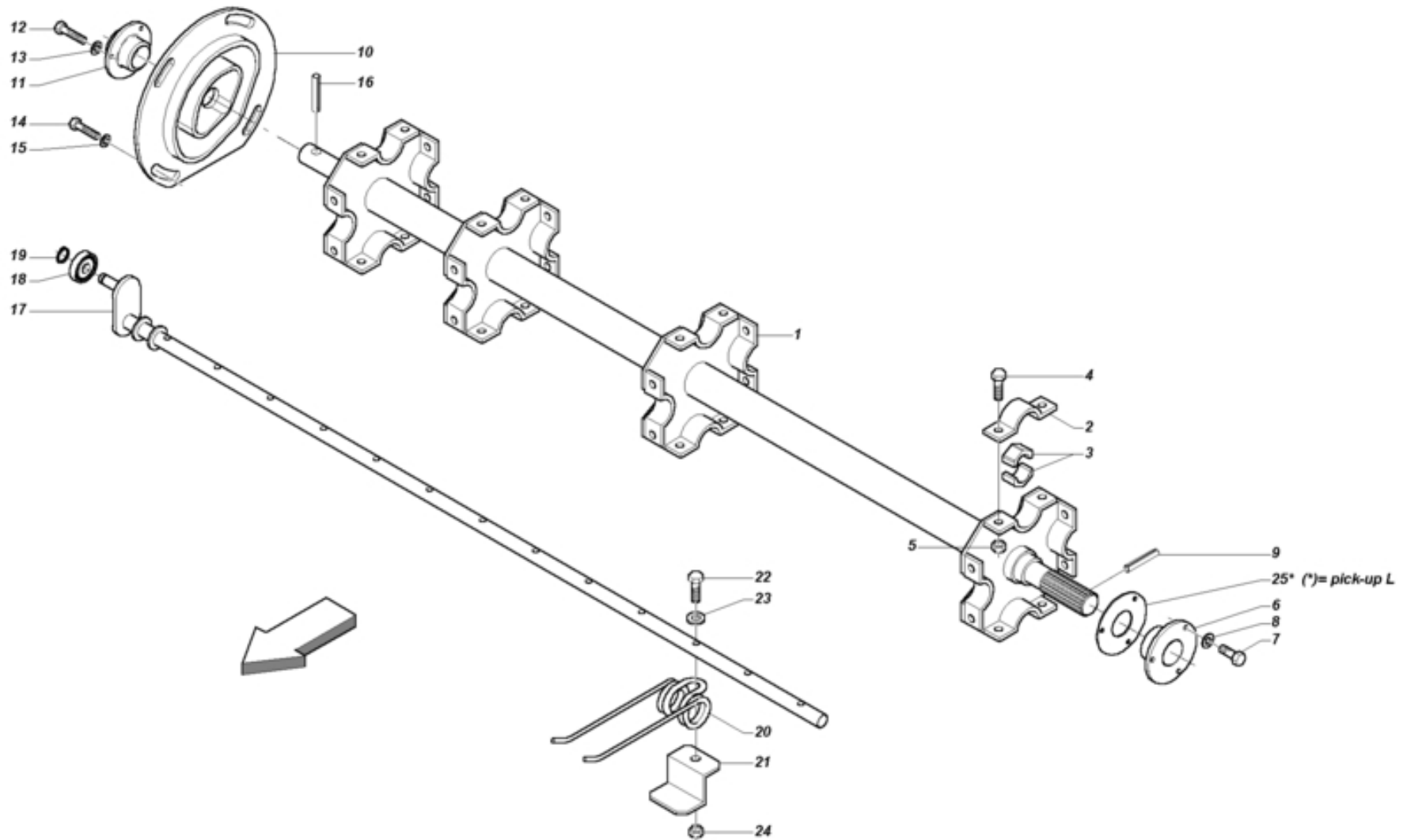



TAV_P000020_00-1-M

Item	Part Num.	Description	Item	Part Num.	Description
p001	7S00993	PICK-UP SHAFT CASING	p024	0910208	NUT
p002	C001521	U BOLT			
p003	25P0010	HALF-BUSH			
p004	0181025	SCREW			
p005	08B0310	NUT			
p006	2353035	FLANGED SUPPORT			
p007	0181020	SCREW			
p008	1421025	WASHER			
p009	1110650	PIN			
p010	7S01561	NEW PICK-UP ECCENTRIC			
p011	2353030	FLANGED SUPPORT			
p012	0181020	SCREW			
p013	1421025	WASHER			
p014	0181225	SCREW			
p015	1523831	FIFTH WHEEL			
p016	1110645	PIN			
p017	7S00991	TINE HOLDER BAR			
p018	20R1210	ROLLER			
p019	1700012	SEEGER RING			
p020	18P0003	PICK-UP TINE			
p021	C000214	SPRING SUPPORTING PLATE			
p022	0170850	SCREW			
p023	1430820	WASHER			

TAV_P000020_00-1-L

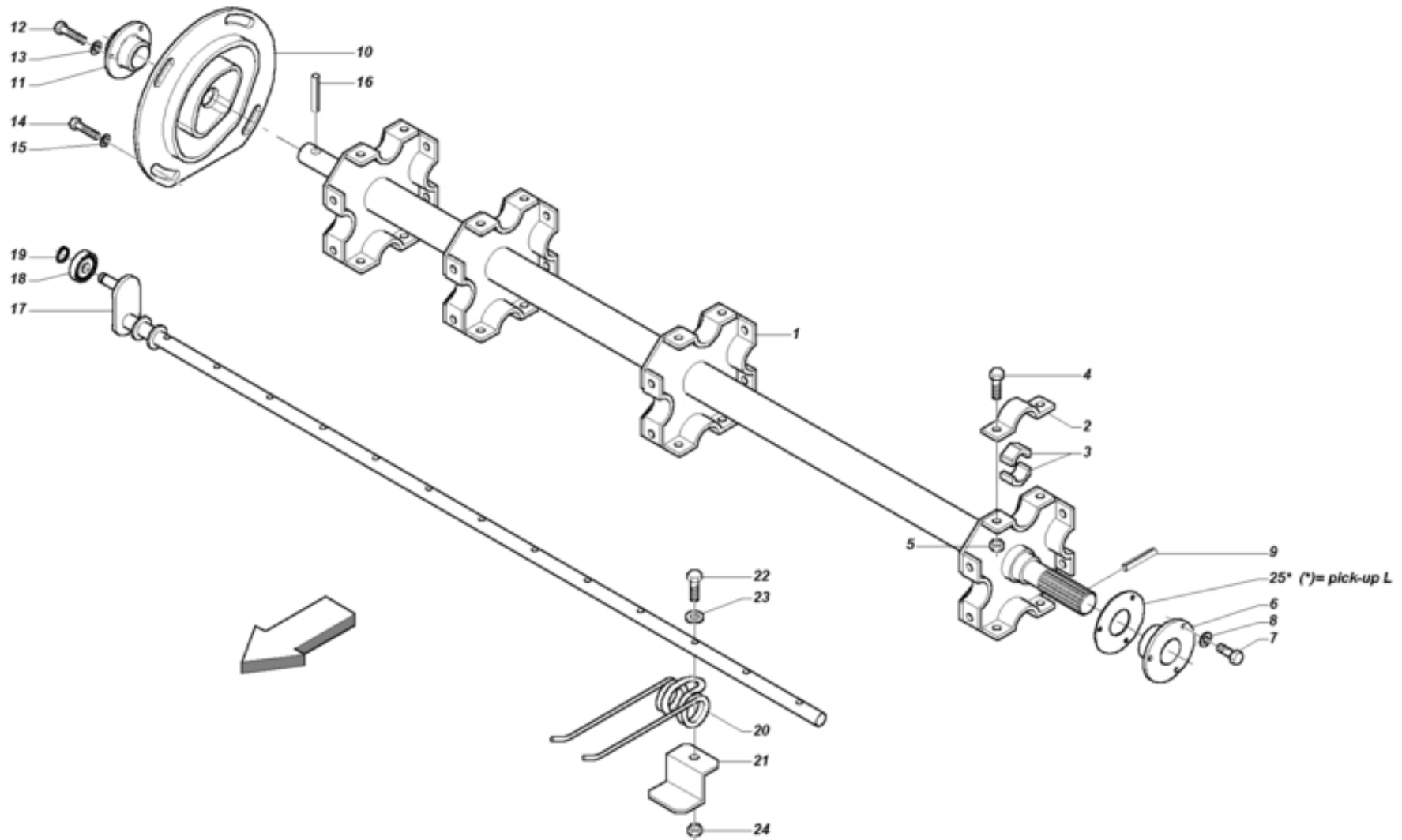

TAV_P000020_00-1-L

Item	Part Num.	Description	Item	Part Num.	Description
p001	7S01223	PICK-UP SHAFT CASING 220	p024	0910208	NUT
p002	C001521	U BOLT	p025	1301126	SHIM
p003	25P0010	HALF-BUSH			
p004	0181025	SCREW			
p005	08B0310	NUT			
p006	2353035	FLANGED SUPPORT			
p007	0181020	SCREW			
p008	1421025	WASHER			
p009	1110650	PIN			
p010	7S01561	NEW PICK-UP ECCENTRIC			
p011	2353030	FLANGED SUPPORT			
p012	0181020	SCREW			
p013	1421025	WASHER			
p014	0181225	SCREW			
p015	1523831	FIFTH WHEEL			
p016	1110645	PIN			
p017	7S01225	TINES-HOLDER BAR 220			
p018	20R1210	ROLLER			
p019	1700012	SEEGER RING			
p020	18P0003	PICK-UP TINE			
p021	C000214	SPRING SUPPORTING PLATE			
p022	0170850	SCREW			
p023	1430820	WASHER			

TAV_P00022_01-M

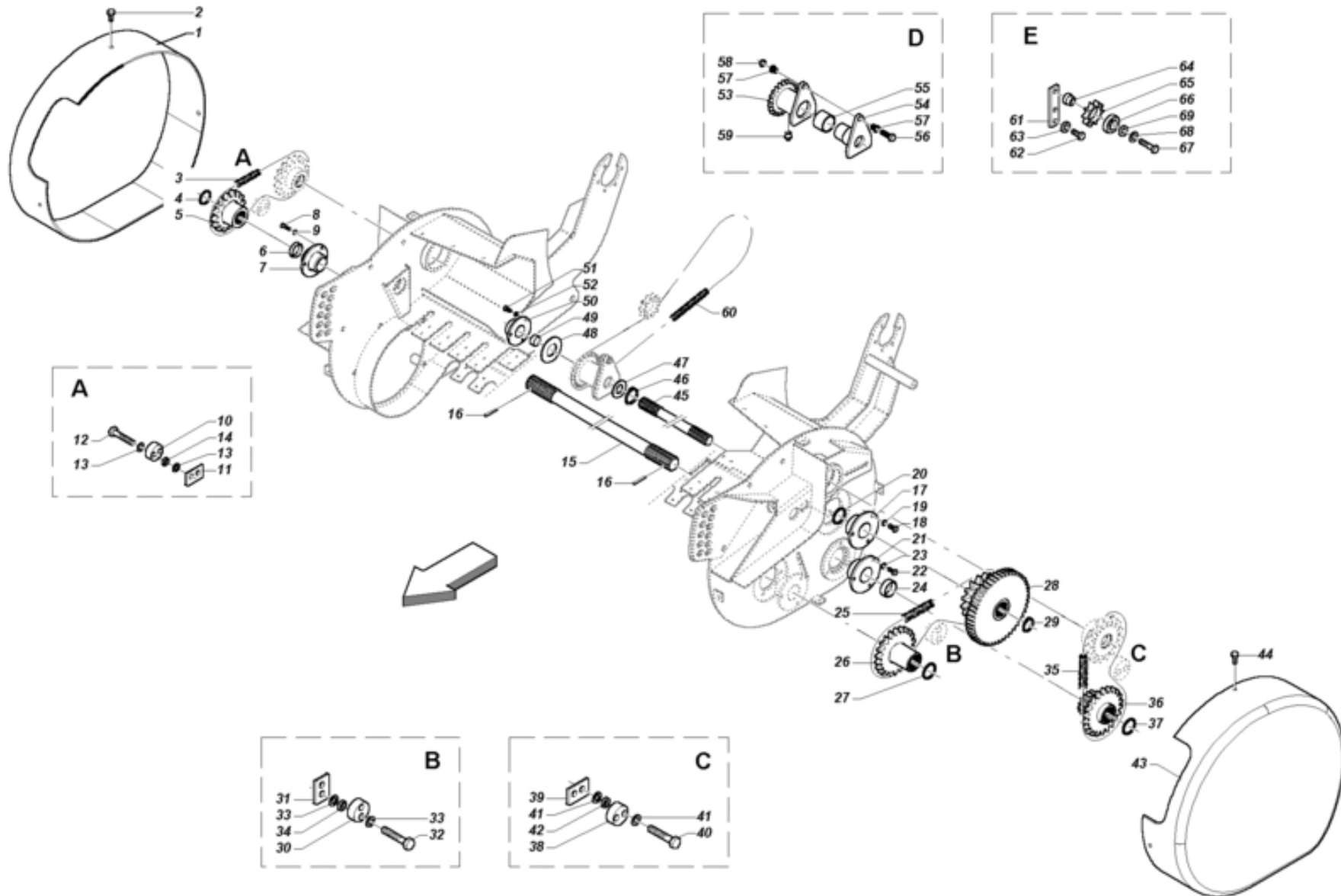

TAV_P00022_01-M

Item	Part Num.	Description	Item	Part Num.	Description
p001	7SP0001	PU RIGHT GUARD	p022	0181025	SCREW
p002	0180820	SCREW	p023	1421025	WASHER
p003	3110007	LINK	p024	1330957	SPACER
p003	3111057	ROLLER CHAIN	p025	3110007	LINK
p004	1534416	SHIM	p025	3111046	ROLLER CHAIN
p005	3400003	GEAR Z=22-3/4"	p026	3400240	GEAR Z=22-3/4" ISO WITH HUB
p006	1330957	SPACER	p027	1300101	SHIM (GALV)
p007	2353035	FLANGED SUPPORT	p028	3L34402	GEAR
p008	0181025	SCREW	p029	1700035	SEEGER RING
p009	1421025	WASHER	p030	7V00031	NYLON CHAIN TIGHTENER
p010	7V00031	NYLON CHAIN TIGHTENER	p031	C003172	CHAIN TIGHTENER COUPLING
p011	C003172	CHAIN TIGHTENER COUPLING	p032	0191260	SCREW
p012	0191270	SCREW	p033	1431225	WASHER
p013	1431225	WASHER	p033	1421230	WASHER
p013	1421230	WASHER	p034	1523831	FIFTH WHEEL
p014	1523831	FIFTH WHEEL	p035	3110007	LINK
p015	3A34361	COUNTERSHAFT	p035	3111057	ROLLER CHAIN
p016	1110650	PIN	p036	3400271	DOUBLE GEAR Z=16/22 WITH HUB
p017	2353035	FLANGED SUPPORT	p037	1534416	SHIM
p018	0181020	SCREW	p038	7V00031	NYLON CHAIN TIGHTENER
p019	1421025	WASHER	p039	C003172	CHAIN TIGHTENER COUPLING
p020	1534416	SHIM	p040	0191270	SCREW
p021	2353035	FLANGED SUPPORT	p041	1421230	WASHER

TAV_P000022_01-M

Item	Part Num.	Description	Item	Part Num.	Description
p041	1431225	WASHER	p063	1518412	FIFTH WHEEL
p042	1523831	FIFTH WHEEL	p064	1300302	PIN
p043	7SP0002	PU LEFT GUARD	p065	3400274	SPROCKET Z=10-1"
p044	0180820	SCREW	p066	2042515	BEARING
p045	3500279	SHORT COUNTERSHAFT 200	p067	0191260	SCREW
p046	1700040	SEEGER RING	p068	1431225	WASHER
p047	1300126	SHIM	p069	1518412	FIFTH WHEEL
p048	1534395	FIFTH WHEEL			
p049	1300607	SPACER			
p050	2353035	FLANGED SUPPORT			
p051	0181020	SCREW			
p052	1421025	WASHER			
p053	3400241	SURETY HUB			
p054	7S01001	SPLINED HUB			
p055	2500001	BUSHING			
p056	0170845	SCREW			
p057	0511057	BUSHING			
p058	08B0208	NUT			
p059	4200610	GREASE NIPPLE			
p060	30E0017	SPRING JOINT			
p060	30E1052	ROLLER CHAIN			
p061	C002390	LOCK			
p062	0181230	SCREW			

TAV_P000022_01-L

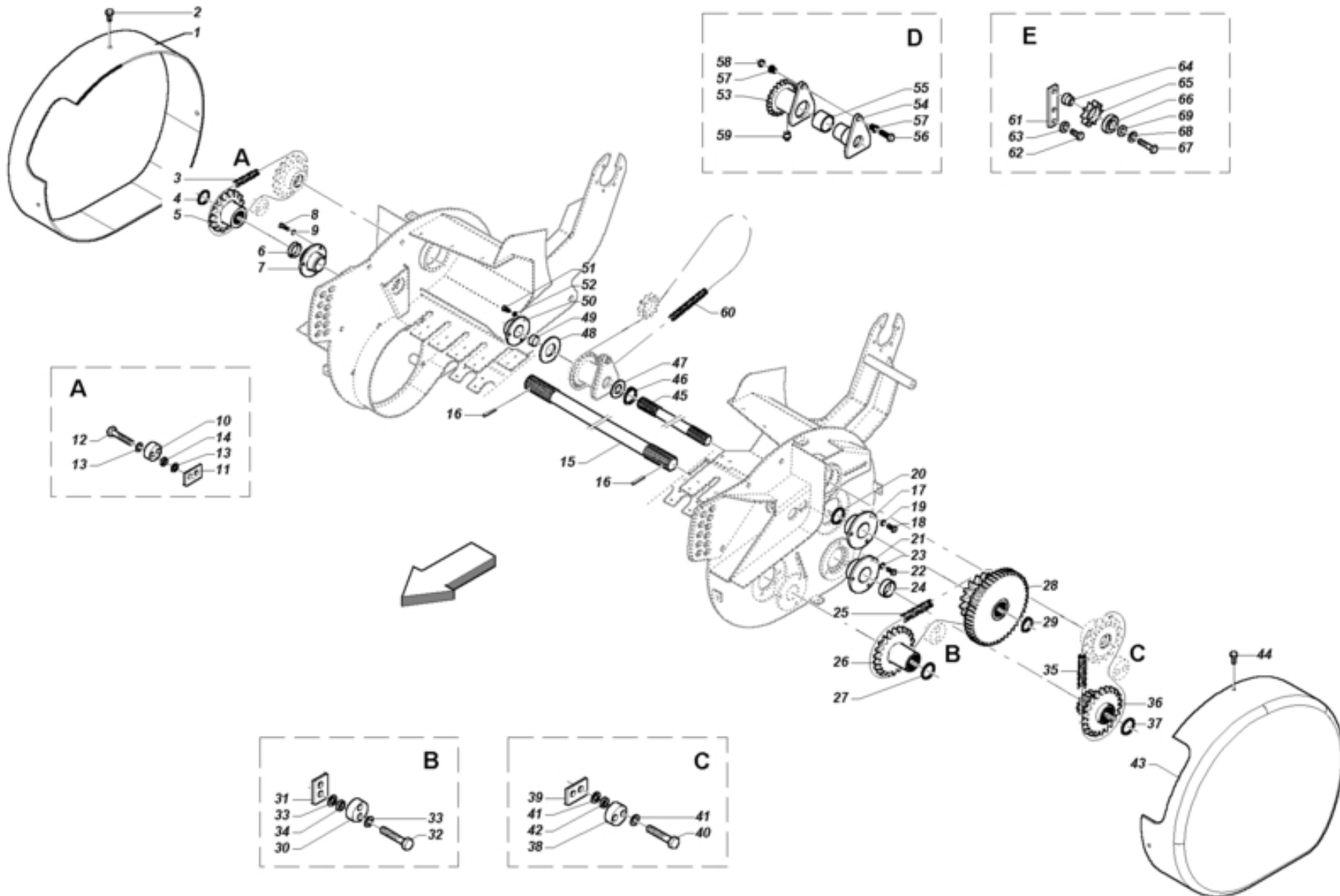

TAV_P000022_01-L

Item	Part Num.	Description	Item	Part Num.	Description
p001	7SP0001	PU RIGHT GUARD	p022	0181025	SCREW
p002	0180820	SCREW	p023	1421025	WASHER
p003	3111057	ROLLER CHAIN	p024	1330957	SPACER
p003	3110007	LINK	p025	3111046	ROLLER CHAIN
p004	1534416	SHIM	p025	3110007	LINK
p005	3400003	GEAR Z=22-3/4"	p026	3400075	GEAR Z=22-3/4" WITH HUB
p006	1330957	SPACER	p027	1534416	SHIM
p007	2353035	FLANGED SUPPORT	p028	3L34402	GEAR
p008	0181025	SCREW	p029	1700035	SEEGER RING
p009	1421025	WASHER	p030	7V00031	NYLON CHAIN TIGHTENER
p010	7V00031	NYLON CHAIN TIGHTENER	p031	C003172	CHAIN TIGHTENER COUPLING
p011	C003172	CHAIN TIGHTENER COUPLING	p032	0191260	SCREW
p012	0191270	SCREW	p033	1431225	WASHER
p013	1431225	WASHER	p033	1421230	WASHER
p013	1421230	WASHER	p034	1523831	FIFTH WHEEL
p014	1523831	FIFTH WHEEL	p035	3110007	LINK
p015	3500045	COUNTERSHAFT 220	p035	3111057	ROLLER CHAIN
p016	1110650	PIN	p036	3400271	DOUBLE GEAR Z=16/22 WITH HUB
p017	2353035	FLANGED SUPPORT	p037	1534416	SHIM
p018	0181020	SCREW	p038	7V00031	NYLON CHAIN TIGHTENER
p019	1421025	WASHER	p039	C003172	CHAIN TIGHTENER COUPLING
p020	1534416	SHIM	p040	0191270	SCREW
p021	2353035	FLANGED SUPPORT	p041	1431225	WASHER

TAV_P000022_01-L

Item	Part Num.	Description	Item	Part Num.	Description
p041	1421230	WASHER	p063	1518412	FIFTH WHEEL
p042	1523831	FIFTH WHEEL	p064	1300302	PIN
p043	7SP0002	PU LEFT GUARD	p065	3400274	SPROCKET Z=10-1"
p044	0180820	SCREW	p066	2042515	BEARING
p045	3500280	SHORT COUNTER SHAFT 220	p067	0191260	SCREW
p046	1700040	SEEGER RING	p068	1431225	WASHER
p047	1300126	SHIM	p069	1518412	FIFTH WHEEL
p048	1534395	FIFTH WHEEL			
p049	1300607	SPACER			
p050	2353035	FLANGED SUPPORT			
p051	0181020	SCREW			
p052	1421025	WASHER			
p053	3400241	SURETY HUB			
p054	7S01001	SPLINED HUB			
p055	2500001	BUSHING			
p056	0170845	SCREW			
p057	0511057	BUSHING			
p058	08B0208	NUT			
p059	4200610	GREASE NIPPLE			
p060	30E1052	ROLLER CHAIN			
p060	30E0017	SPRING JOINT			
p061	C002390	LOCK			
p062	0181230	SCREW			

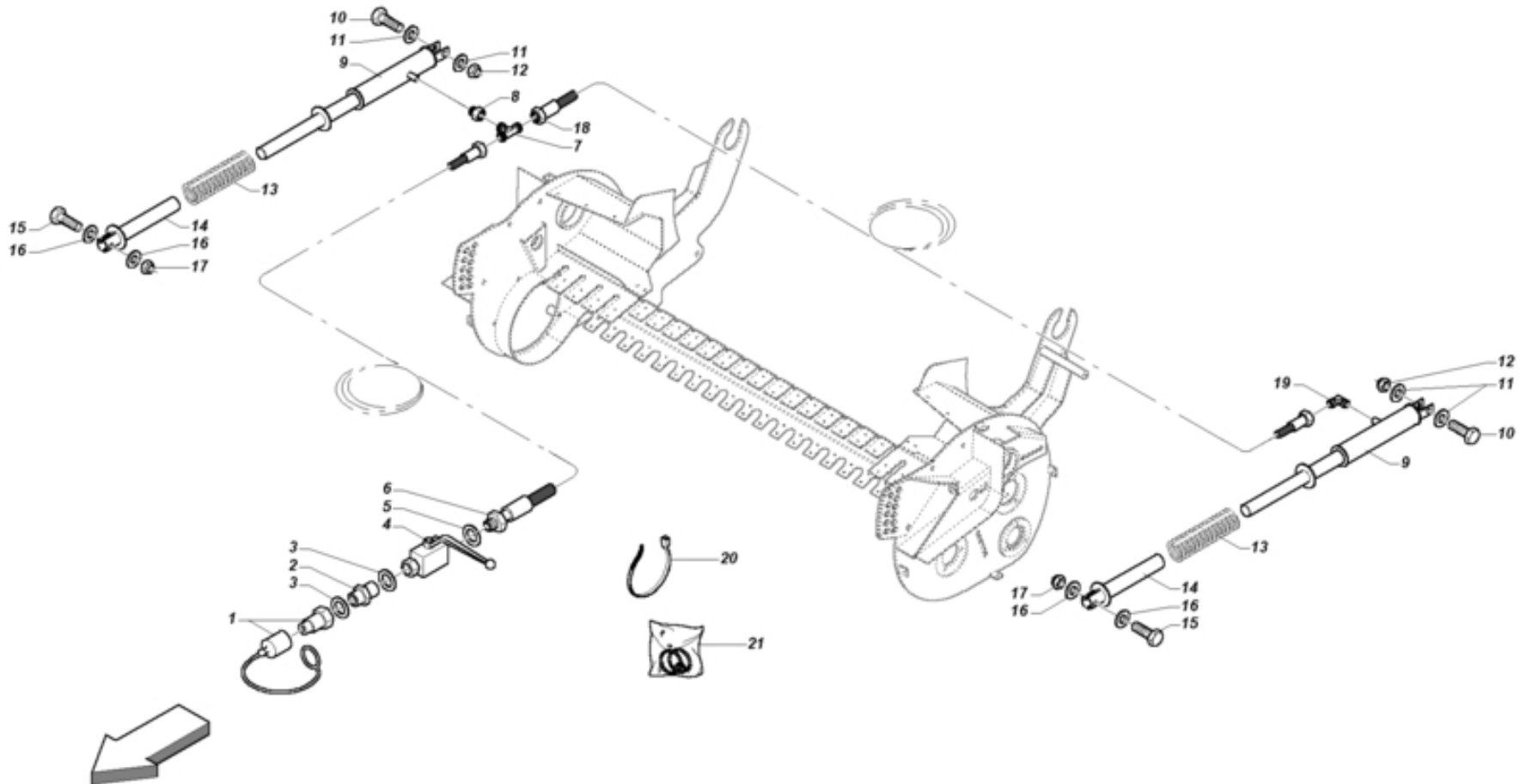

Item	Part Num.	Description	
p001	H6000A0	QUICK CLUTCH	
p002	H733671	NIPPLE 1/2"-1/4"	
p003	1441415	WASHER	
p004	H000119	BALL COCK	
p005	1442015	WASHER	
p006	H000250	HYDRAULIC HOSE	
p007	H000264	"T" FITTING TN96-10LR	
p008	H000265	REDUCTION TN143-3/8"X1/4"R	
p009	H400072	SPRINTER PICK-UP JACK "CUT"	
p010	0191660	SCREW	
p011	1421630	WASHER	
p012	0920516	NUT	
p013	1800062	TOPCUT PICK-UP TINE	
p014	7S01072	JACK GUIDE	
p015	0191660	SCREW	
p016	1421630	WASHER	
p017	0920516	NUT	
p018	H000251	HYDRAULIC HOSE	
p019	H000086	UNION "L"10	
p020	E600021	CLAMP LUMEFIX	
p021	H400061	KIT JOINTS FOR H400021	

TAV_P00025_00-M

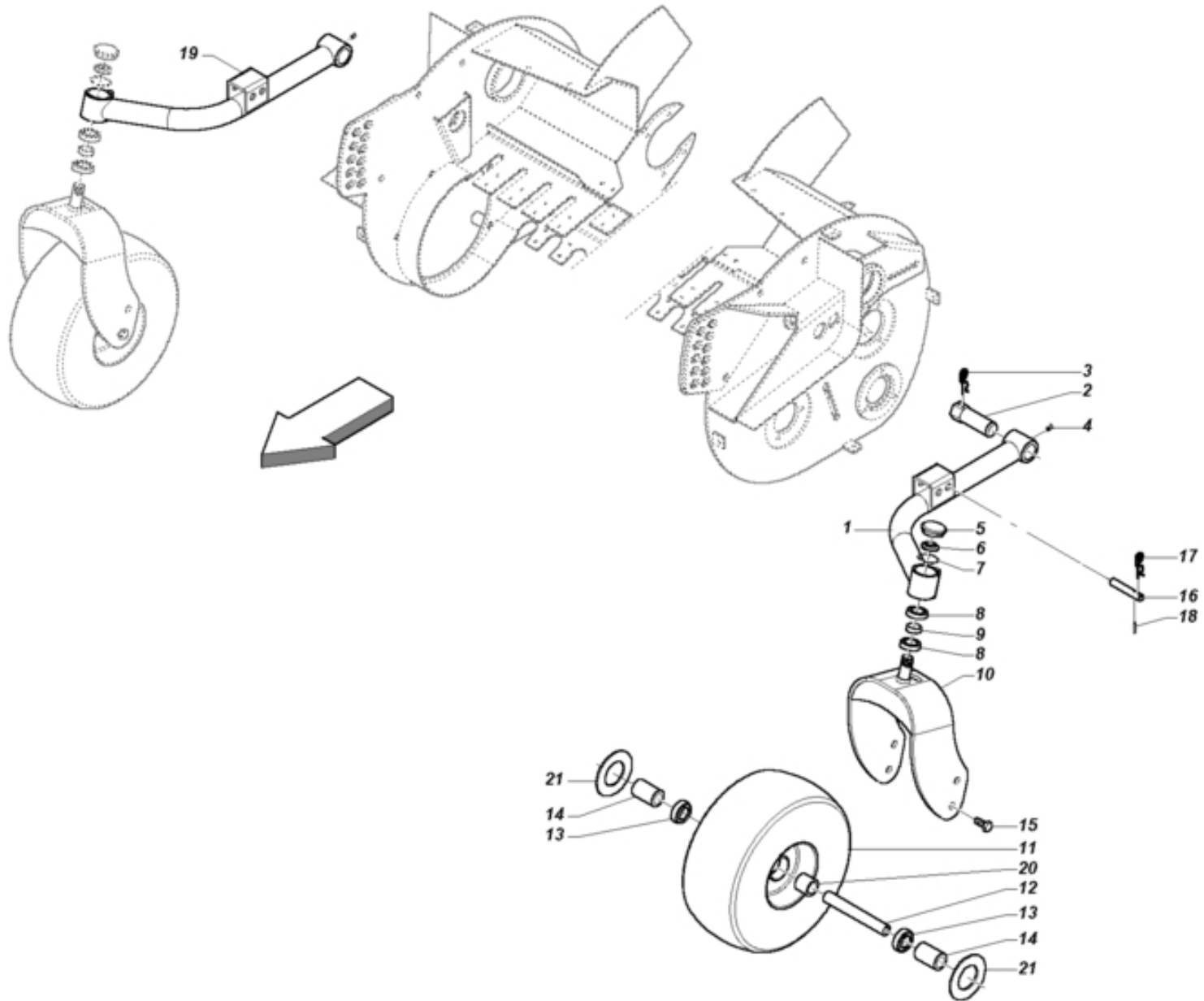

Item	Part Num.	Description	
p001	7S01559	LEFT PICK-UP WHEEL ARM 200	
p002	0500079	WHEEL ARM PIN	
p003	11B0499	PIN	
p004	4220610	GREASE NIPPLE	
p005	4400002	CAP	
p006	0941325	RING NUT	
p007	1710047	SEEGER RING	
p008	2042512	BEARING	
p009	1300934	SPACER	
p010	7S01557	WHEEL SUPPORT	
p011	7100045	RUBBER WHEEL	
p012	1300336	PICK-UP WHEELS SPINDLE	
p013	2040005	BEARING	
p014	1301058	SPACER	
p015	0181630	SCREW	
p016	1301065	PIN	
p017	11B0499	PIN	
p018	1110530	PIN	
p019	7S01555	RIGHT PICK-UP WHEEL ARM 200	
p020	1300919	SPACER	
p021	1300918	DIAM. 25 HOLE FLANGE	

TAV_P000025_00-L

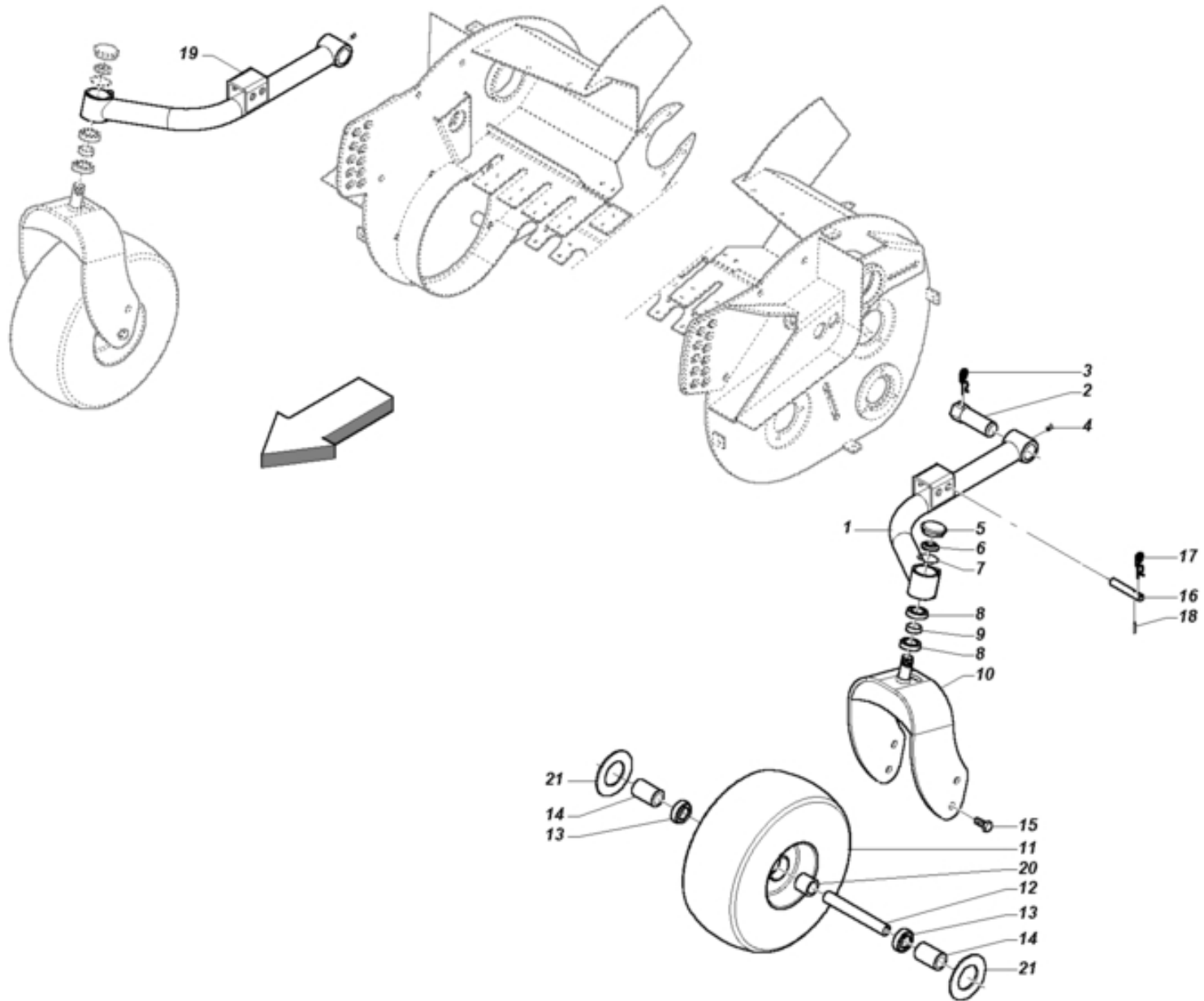

Item	Part Num.	Description	
p001	7S01807	LEFT PICK-UP WHEEL ARM	
p002	0500079	WHEEL ARM PIN	
p003	11B0499	PIN	
p004	4220610	GREASE NIPPLE	
p005	4400002	CAP	
p006	0941325	RING NUT	
p007	1710047	SEEGER RING	
p008	2042512	BEARING	
p009	1300934	SPACER	
p010	7S01557	WHEEL SUPPORT	
p011	7100045	RUBBER WHEEL	
p012	1300336	PICK-UP WHEELS SPINDLE	
p013	2040005	BEARING	
p014	1301058	SPACER	
p015	0181630	SCREW	
p016	1301065	PIN	
p017	11B0499	PIN	
p018	1110530	PIN	
p019	7S01793	RIGHT PICK-UP WHEEL ARM 220	
p020	1300919	SPACER	
p021	1300918	DIAM. 25 HOLE FLANGE	

TAV_P000028_01-265

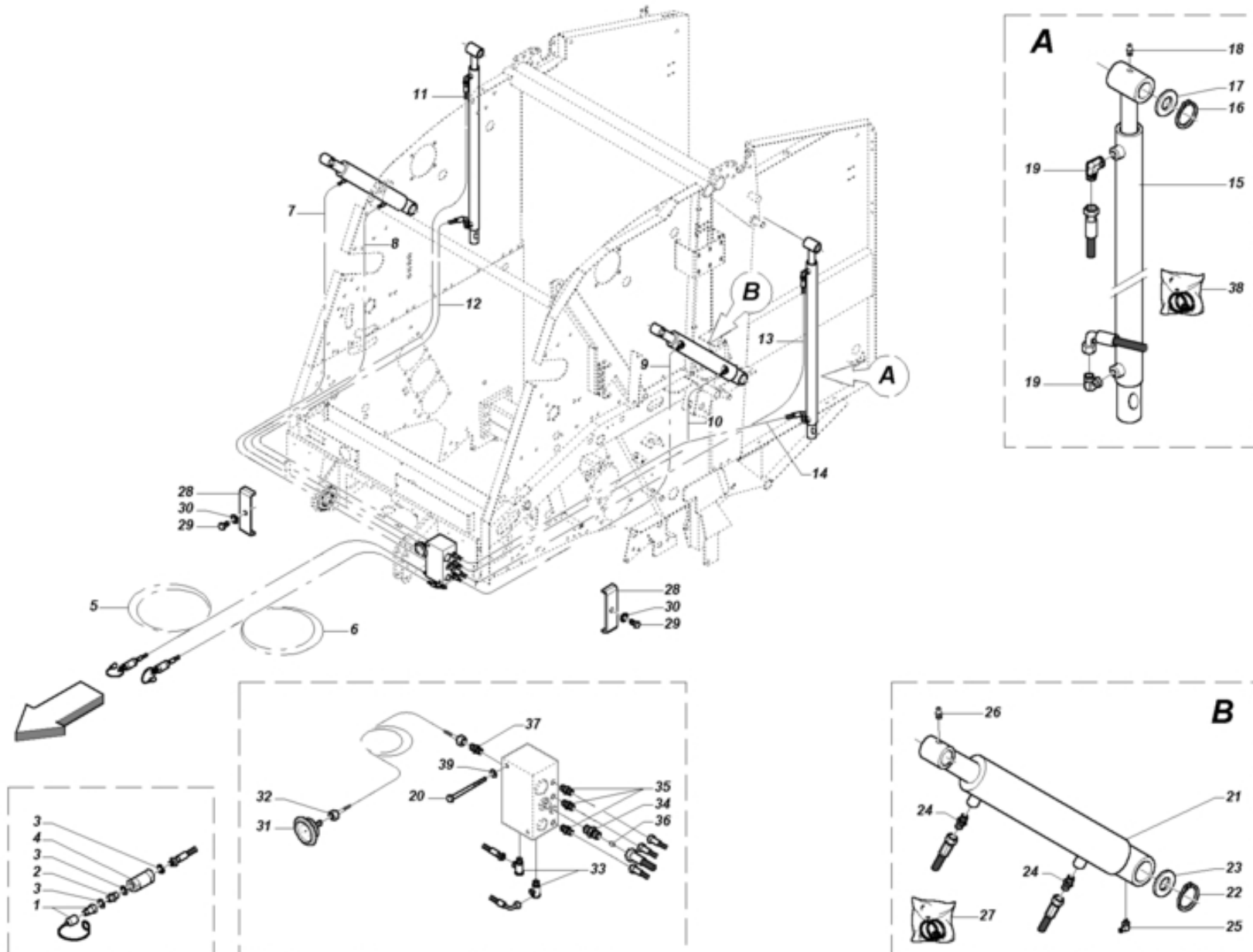

TAV_P000028_01-265

Item	Part Num.	Description	Item	Part Num.	Description
p001	H6000A0	QUICK CLUTCH	p022	1700035	SEEGER RING
p002	H6000AX	NIPPLE 1/2"	p023	1519696	SHIM
p003	1442015	WASHER	p024	H0P0006	
p004	H000040	FILTER IL12/60 R 94001261	p025	4220610	GREASE NIPPLE
p005	H000253	HYDRAULIC HOSE	p026	4200610	GREASE NIPPLE
p006	H000254	HYDRAULIC HOSE	p027	H400146	SEAL KIT FOR H400128-129-134
p007	H000248	BLUE HYDRAULIC HOSE	p028	C005132	FIXING U BOLT
p008	H000247	YELLOW HYDRAULIC HOSE	p029	0180840	SCREW
p009	H000249	BLUE HYDRAULIC HOSE	p030	1420820	WASHER
p010	H000246	YELLOW HYDRAULIC HOSE	p031	H000256	GAUGE HT
p011	H000243	HYDRAULIC HOSE	p032	H000255	CAPILLARY HOSE
p012	H000244	RED HYDRAULIC HOSE	p033	H000103	FILLET "0"12
p013	H000242	HYDRAULIC HOSE	p034	H000182	OIL FLOW REDUCER PIPE FITTING
p014	H000245	RED HYDRAULIC HOSE	p035	H000139	UNION "I" 10
p015	H400130	REAR DOOR JACK 265	p036	0500070	DOWEL M8 WITH HOLE 1.75MM
p016	1700030	SEEGER RING	p037	H000140	NIPPLE 1/4-1/4
p017	1300153	SHIM (GALV)	p038	H400147	SEAL KIT FOR H400130-131-135
p017	1300100	SHIM (GALV)	p039	1430620	WASHER
p017	1300101	SHIM (GALV)			
p018	4200610	GREASE NIPPLE			
p019	H000009	UNION ELBOW 10			
p020	0190690	SCREW			
p021	H400128	PRESSURE JACK 265			

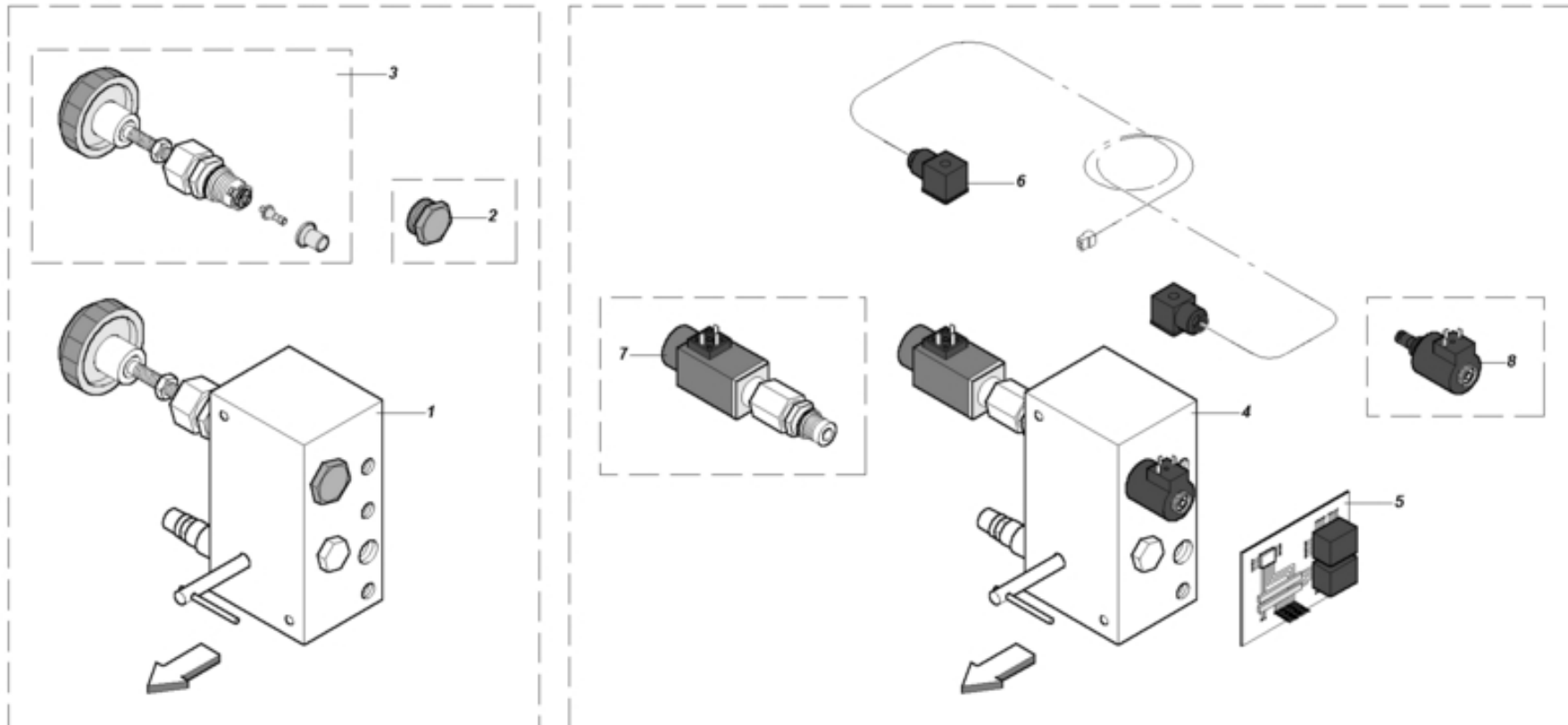

Item	Part Num.	Description	
p001	H000261	VALVE FRB09/M-B WITH TAP	
p002	H000278		
p003	H000277		
p004	H000262	VALVE FRB09/E-B WITH TAP	
p005	E000095	GEOMETRY/PRESSURE CIRCUIT BOARD	
p006	E000097	BALER WIRING	
p007	H000279	VALVE HYDRAULICS	
p008	H000281	VALVE HYDRAULICS ON/OFF	

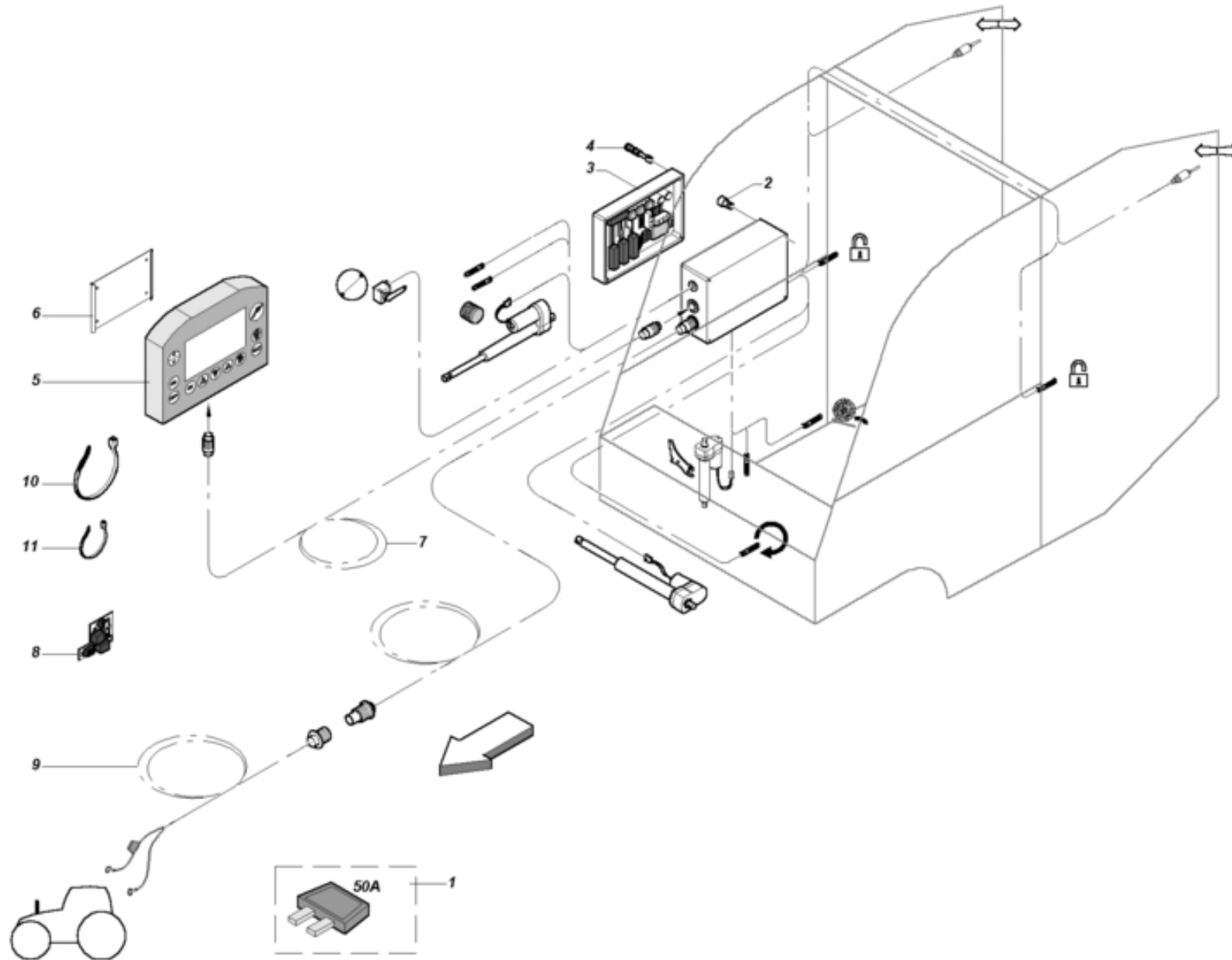

Item	Part Num.	Description	
p001	E000135	50A RED BLADE FUSE	
p002	0400420	SCREW	
p003	E000103	COVER AND CARD	
p004	E000085	PLATIC SCREWS FOR COVER	
p005	E000106	DISPLAY	
p006	E000088	FEMALE DOVE TAIL SHAPED SUPPORT	
p007	E000089	DATA TRANSFER CABLE	
p008	E000092	PRINTED CIRCUIT BOARD "CUT"	
p009	E000090	TRACTOR CABLE	
p010	E600001	CLAMP 8X2	
p011	E600021	CLAMP LUMEFIX	

TAV_P00029_03

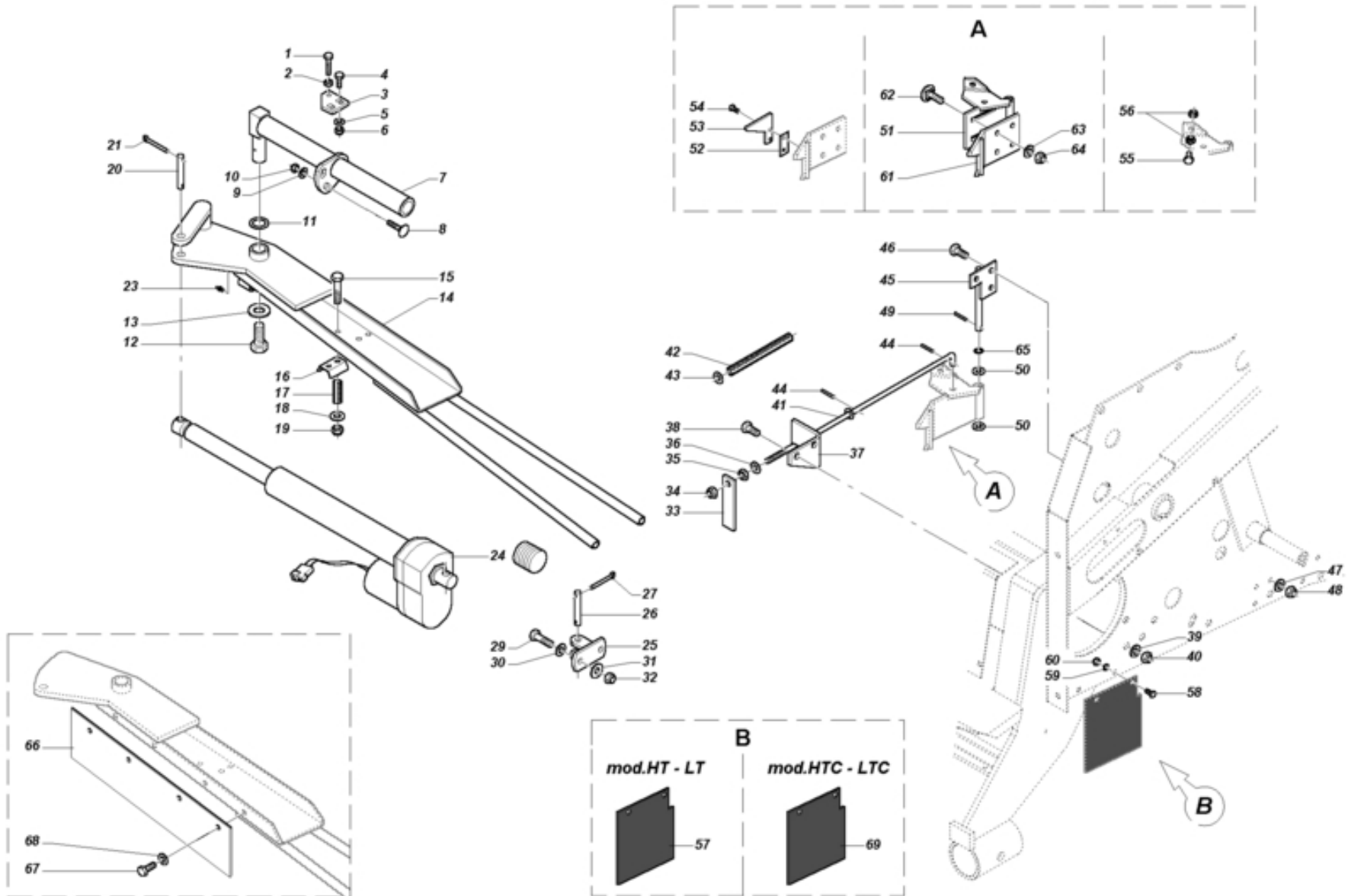

TAV_P000029_03

Item	Part Num.	Description	Item	Part Num.	Description
p001	0181050	SCREW	p024	E000120	ACTUATOR
p002	0710310	NUT	p025	7S01525	ACTUATOR ATTACHMENT
p003	C005031	LOCK	p026	1A29508	CYLINDER PIN
p004	0181030	SCREW	p027	1150430	GALV PIN
p005	1421025	WASHER	p029	0181245	SCREW
p006	0545790	SELF-LOCKING NUT	p030	1421230	WASHER
p007	7S01524	CROSS BAR	p031	1431225	WASHER
p008	0321235	SCREW	p032	0920412	NUT
p009	1421230	WASHER	p033	C003115	COUPLER
p010	0920412	NUT	p034	0920208	NUT
p011	1300134	SHIM	p035	0710208	NUT
p011	1300135	SHIM	p036	1420820	WASHER
p012	0181630	SCREW	p037	C005034	ROD SUPPORT
p013	1519319	FIFTH WHEEL	p038	0181240	SCREW
p014	7S01805	TWINE WRAPPING ARM	p039	1421230	WASHER
p015	0180840	SCREW	p040	0920412	NUT
p016	C630434	TWINE BRAKE	p041	0500098	ADJUSTMENT BAR
p017	1821993	SPRING	p042	1800036	C-SPRING
p018	1420820	WASHER	p043	1420820	WASHER
p019	0920208	NUT	p044	1110320	PIN
p020	1A29508	CYLINDER PIN	p045	7S00987	BLADE FULCRUM
p021	1150430	GALV PIN	p046	0180820	SCREW
p023	4200610	GREASE NIPPLE	p047	1420820	WASHER

Item	Part Num.	Description	
p048	0920208	NUT	
p049	1110320	PIN	
p050	1421025	WASHER	
p051	7SP0044	CUTTING FULCRUM	
p052	7U00011	BLADE BY MARTOR ART. 37	
p053	C002765	BLADE FASTERNER	
p054	0180516	SCREW	
p055	0180825	SCREW	
p056	0710208	NUT	
p057	7V00080	TWINE TYING KIT PROTECTION	
p058	0180820	SCREW	
p059	1430820	WASHER	
p060	0920208	NUT	
p061	7SP0045	BLADE HOLDER	
p062	0320825	SCREW	
p063	1420820	WASHER	
p064	0920208	NUT	
p065	4313037	TORIC RING	
p066	7VP0004	TWINE WRAP ARM PROTECTION	
p067	0370615	SCREW	
p068	1430620	WASHER	
p069	7V00072	SIDE RUBBERED PROTECTIONS	

TAV_P000031_01

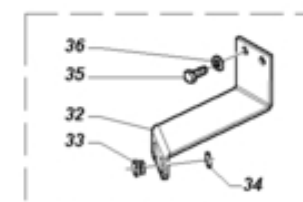
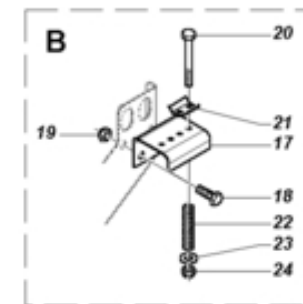
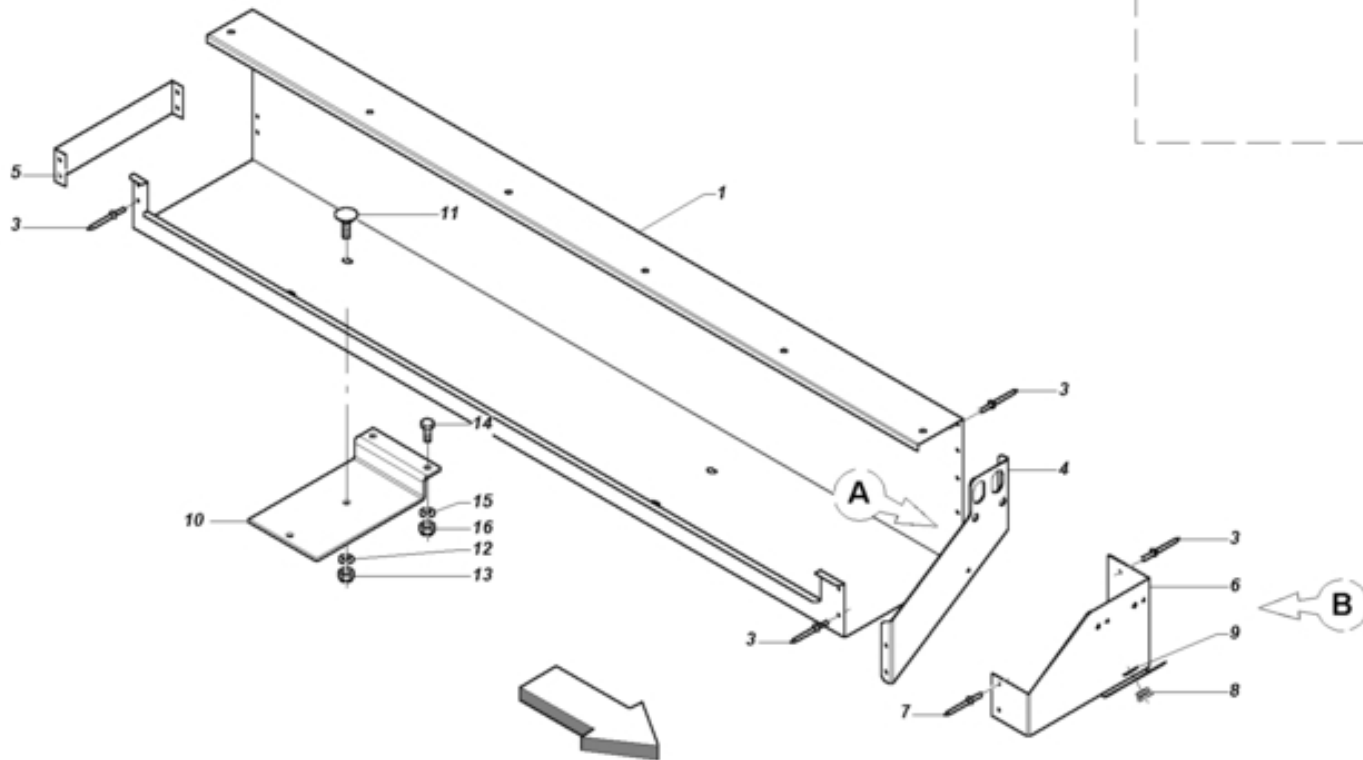
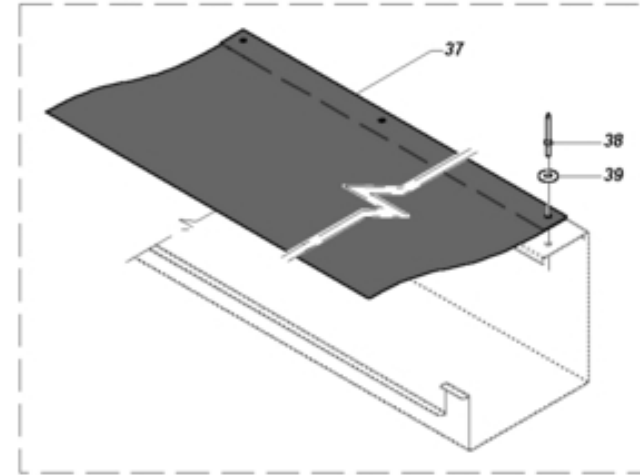
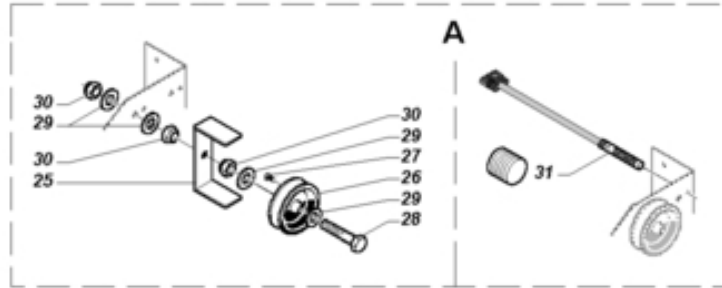
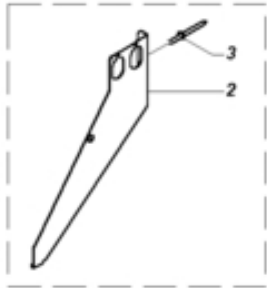

TAV_P000031_01

Item	Part Num.	Description	Item	Part Num.	Description
p001	C004698	TWINE BOX FRAME	p024	0920208	NUT
p002	C005137	PARTITION	p025	C230438	LOCK
p003	1000010	RIVET	p026	3730455	PULLEY
p004	C004699	PARTITION	p027	03F4813	SCREW
p005	C005014	TERMINAL LOCK	p028	0180655	SCREW
p006	C005016	PULLEY ATTACHMENT	p029	1420615	WASHER
p007	1000011	RIVET	p030	0920106	NUT
p008	3500097	TWINE GUIDE BUSH	p031	E000102	PROXIMITY SENSORS
p009	1700025	SEEGER RING	p032	C005002	BUSH ATTACHMENT
p010	C004685	TWINE BOX HOLDER	p033	3500097	TWINE GUIDE BUSH
p011	0321020	SCREW	p034	1700025	SEEGER RING
p012	1431020	WASHER	p035	0181235	SCREW
p013	0920412	NUT	p036	1421230	WASHER
p014	0181030	SCREW	p037	7VP0002	TWINE BOX COVER 265-280
p015	1431020	WASHER	p038	1000010	RIVET
p016	0545790	SELF-LOCKING NUT	p039	1430620	WASHER
p017	C005012	TWINE BRAKE BASE			
p018	0181220	SCREW			
p019	0920412	NUT			
p020	0190840	SCREW			
p021	C630434	TWINE BRAKE			
p022	1821993	SPRING			
p023	1420820	WASHER			

TAV_P000109_00

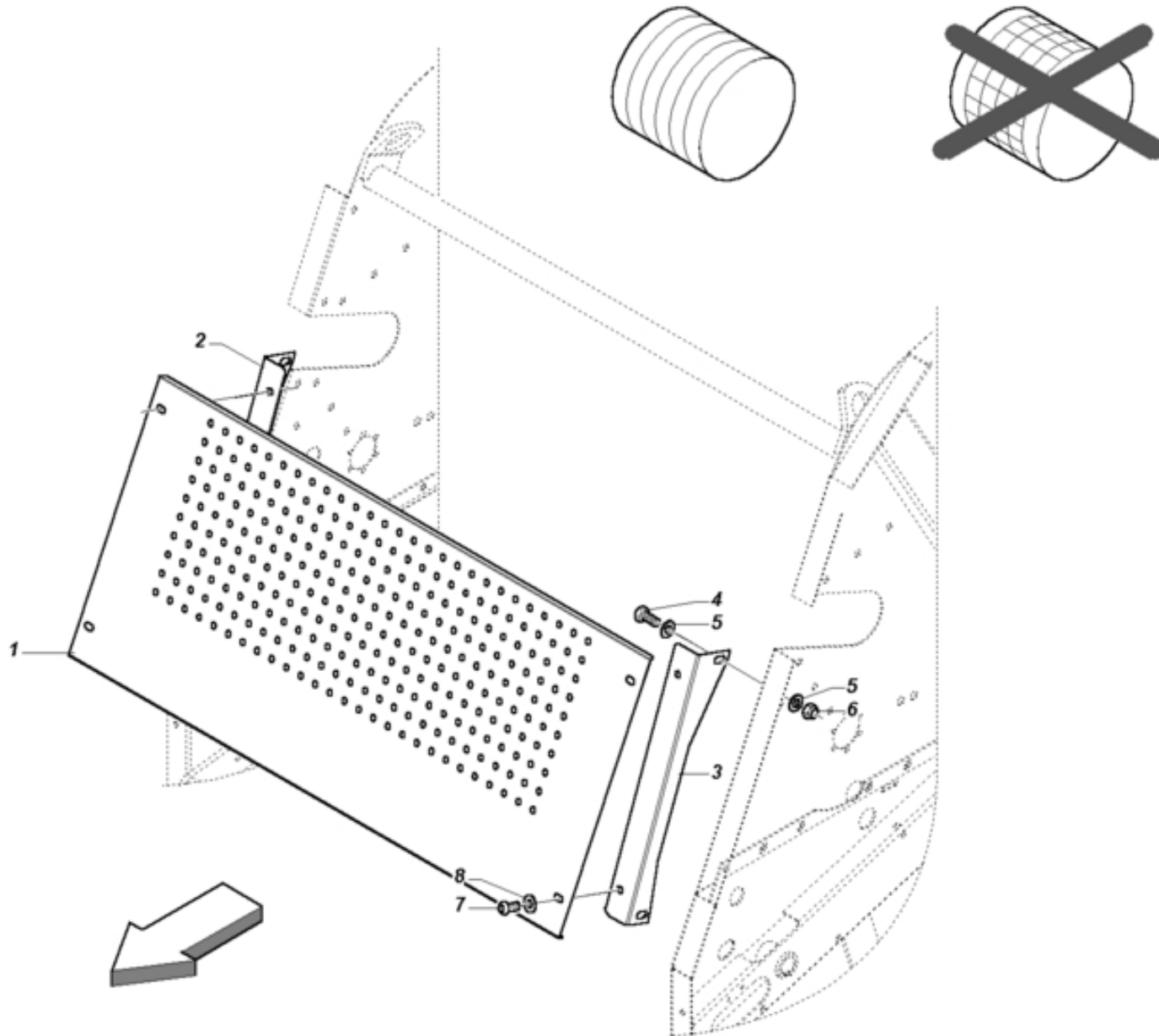

Item	Part Num.	Description	
p001	C3P0009	ONLY TWINE PROTECTION	
p002	C3P0007	TWINE RIGHT PROTECTION ATTACHMENT	
p003	C3P0008	TWINE LEFT PROTECTION ATTACHMENT	
p004	0181225	SCREW	
p005	1421230	WASHER	
p006	0920412	NUT	
p007	0470825	SCREW	
p008	1430820	WASHER	

TAV_P00057_01

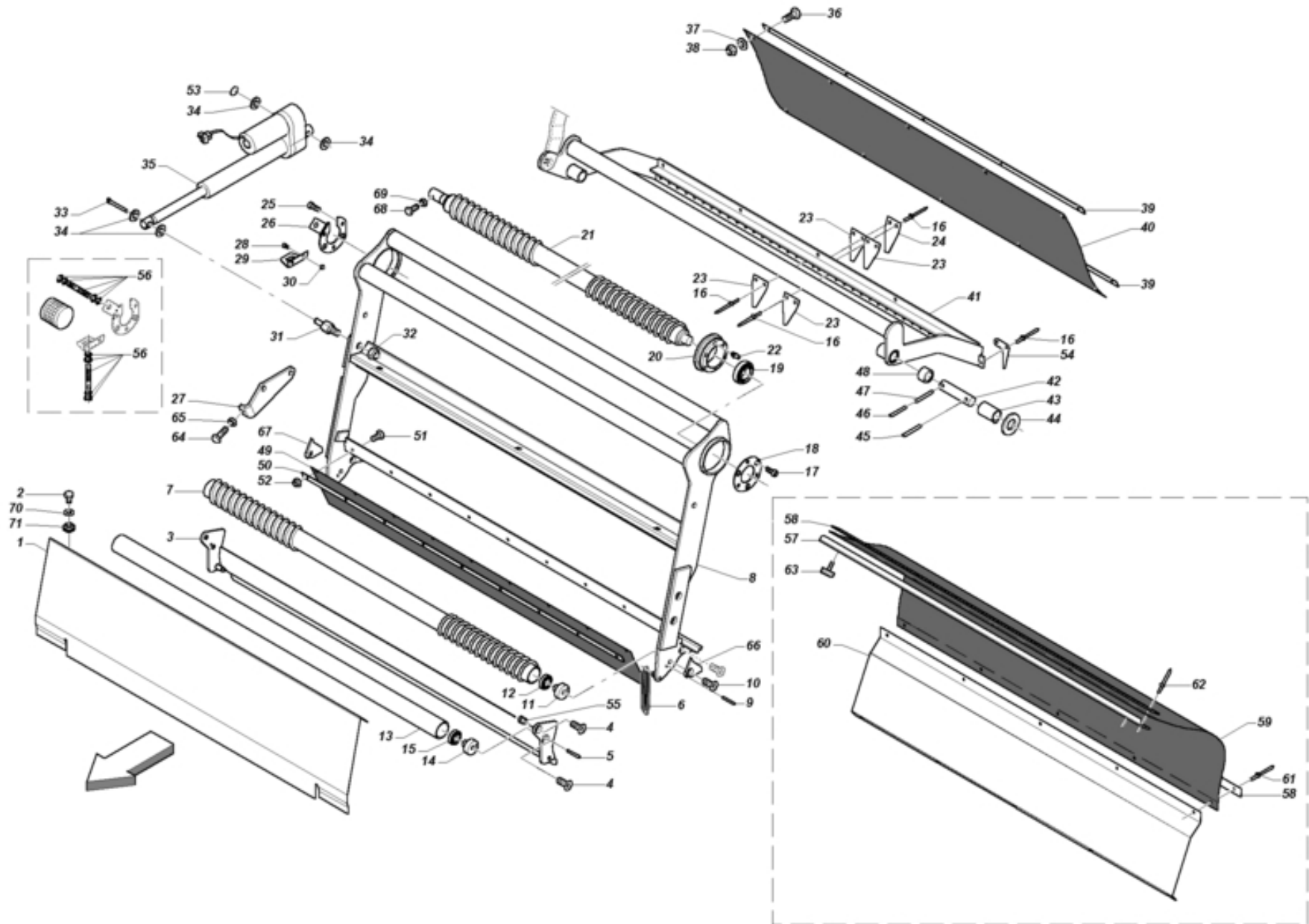

Item	Part Num.	Description	Item	Part Num.	Description
p001	C3P0035	NET HOLDER PROTECTION	p024	C6P0044	SMALL BLADES SHIM
p002	0180815	SCREW	p025	0400825	SCREW
p003	7SP0020	NET CLAMP	p026	C004932	PLATE
p004	0441020	SCREW	p027	C4P0009	LOCK
p005	1110612	PIN	p028	0180620	SCREW
p006	1800025	SPRING	p029	C005200	NET SENSOR COUPLING
p007	7S00648	IDLE ROLLER	p030	0920106	NUT
p008	7SP0090	NET HOLDER ARM	p031	3500063	ECCENTRIC PIN
p009	1110612	PIN	p032	0920516	NUT
p010	0441025	SCREW	p033	1150330	GALV PIN
p011	35P0008	NEW IDLE ROLLER PIN	p034	1421230	WASHER
p012	2301716	BEARING	p035	E000045	ACTUATOR
p013	7SP0100	SMOOTH IDLE ROLLER BODY	p036	0180620	SCREW
p014	35P0008	NEW IDLE ROLLER PIN	p037	1420615	WASHER
p015	2301716	BEARING	p038	0920106	NUT
p016	1000013	RIVET	p039	C002398	RUBBERHOLDER
p017	0400825	SCREW	p040	7VP0010	CLOTH CLOSURE FOR BLADE
p018	1300389	FLANGE	p041	7SP0027	BLADE ARM
p019	2042517	BEARING	p042	1300390	ARM LEFT PIN
p020	2700044	NET AND ROLLER ARM SUPPORT	p043	2526852	NYLON BUSH
p021	7S00649	NET COUNTER ROLLER	p044	1522663	SHIM
p022	4200820	GREASE NIPPLE	p045	1110840	PIN
p023	7U00012	SMALL BLADE	p046	1110840	PIN

Item	Part Num.	Description	Item	Part Num.	Description
p047	1110540	PIN	p070	1420820	WASHER
p048	13C0012	SPACER	p071	0990003	NUT
p049	7VP0001	SUPPORT BAND			
p050	C2P0020	RUBBER HOLDER			
p051	0180620	SCREW			
p052	0920106	NUT			
p053	1700012	SEEGER RING			
p054	C6P0050	BLADE END			
p055	1300401	PIN WITHOUT NET			
p056	E000056	PROXIMITY SENSOR			
p057	7MP0017	PROTECTION SUPPORT			
p058	C002398	RUBBERHOLDER			
p059	7V00062	RUBBER CLOSING			
p060	C2P0030	LOWER PROTECTION			
p061	1000010	RIVET			
p062	1000011	RIVET			
p063	7V00106	KNOB WHEEL			
p064	0181250	SCREW			
p065	0710412	NUT			
p066	C6P0029	STILL LEFT ROLLER NET			
p067	C6P0069	STILL RIGHT ROLLER NET			
p068	0180825	SCREW			
p069	0710208	NUT			

TAV_P000123_00

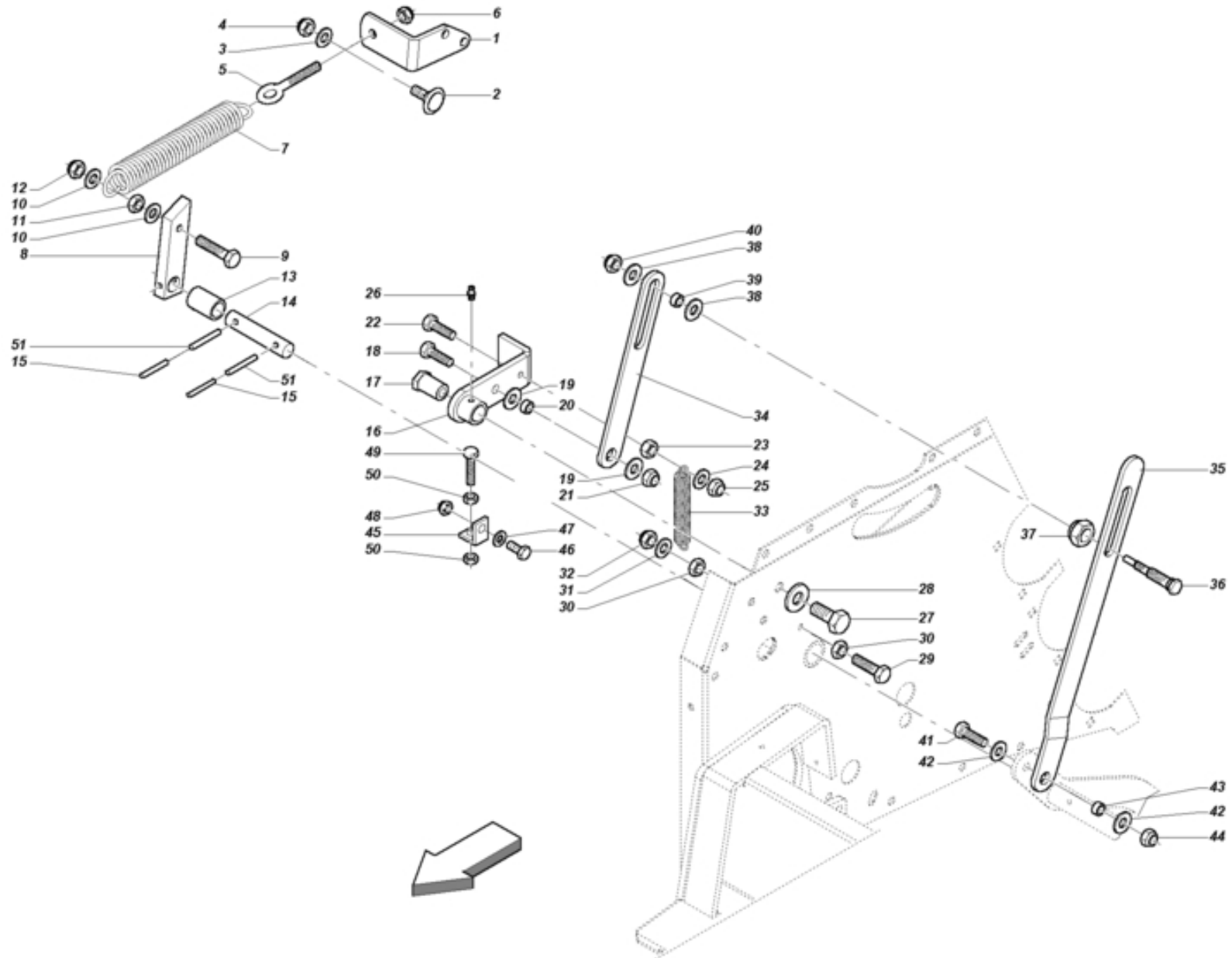

TAV_P000123_00

Item	Part Num.	Description	Item	Part Num.	Description
p001	C6P0045	RELEASING SPRING CONNECTION	p024	1420820	WASHER
p002	05C0003		p025	0920208	NUT
p003	1421230	WASHER	p026	4200610	GREASE NIPPLE
p004	0920412	NUT	p027	0181630	SCREW
p005	0545168	EYELET M12	p028	1519319	FIFTH WHEEL
p006	0920412	NUT	p029	0180825	SCREW
p007	1822744	SPRING	p030	0710208	NUT
p008	C002073	BLADE UNLOCK	p031	1420820	WASHER
p009	0181260	SCREW	p032	0920208	NUT
p010	1421230	WASHER	p033	1800025	SPRING
p011	0710412	NUT	p034	C002081	BLADE UNLOCK LEVER
p012	0920412	NUT	p035	C002043	BLADE CONNECTION
p013	2526852	NYLON BUSH	p036	1301103	BLADE PIN
p014	1301055	PIN	p037	0920516	NUT
p015	1110540	PIN	p038	1431225	WASHER
p016	7T00026	RELEASE	p039	1300463	BUSH
p017	0500093	THREADED PIN	p040	0920412	NUT
p018	0181240	SCREW	p041	0181235	SCREW
p019	1431225	WASHER	p042	1431225	WASHER
p020	1300463	BUSH	p043	1300463	BUSH
p021	0920412	NUT	p044	0920412	NUT
p022	0180830	SCREW	p045	C000053	KNIVES STOP
p023	0710208	NUT	p046	0181230	SCREW



TAV_P000123_00

Item	Part Num.	Description	
p047	1421230	WASHER	
p048	0920412	NUT	
p049	0181060	SCREW	
p050	0710310	NUT	
p051	1110840	PIN	

TAV_P000032_00-2

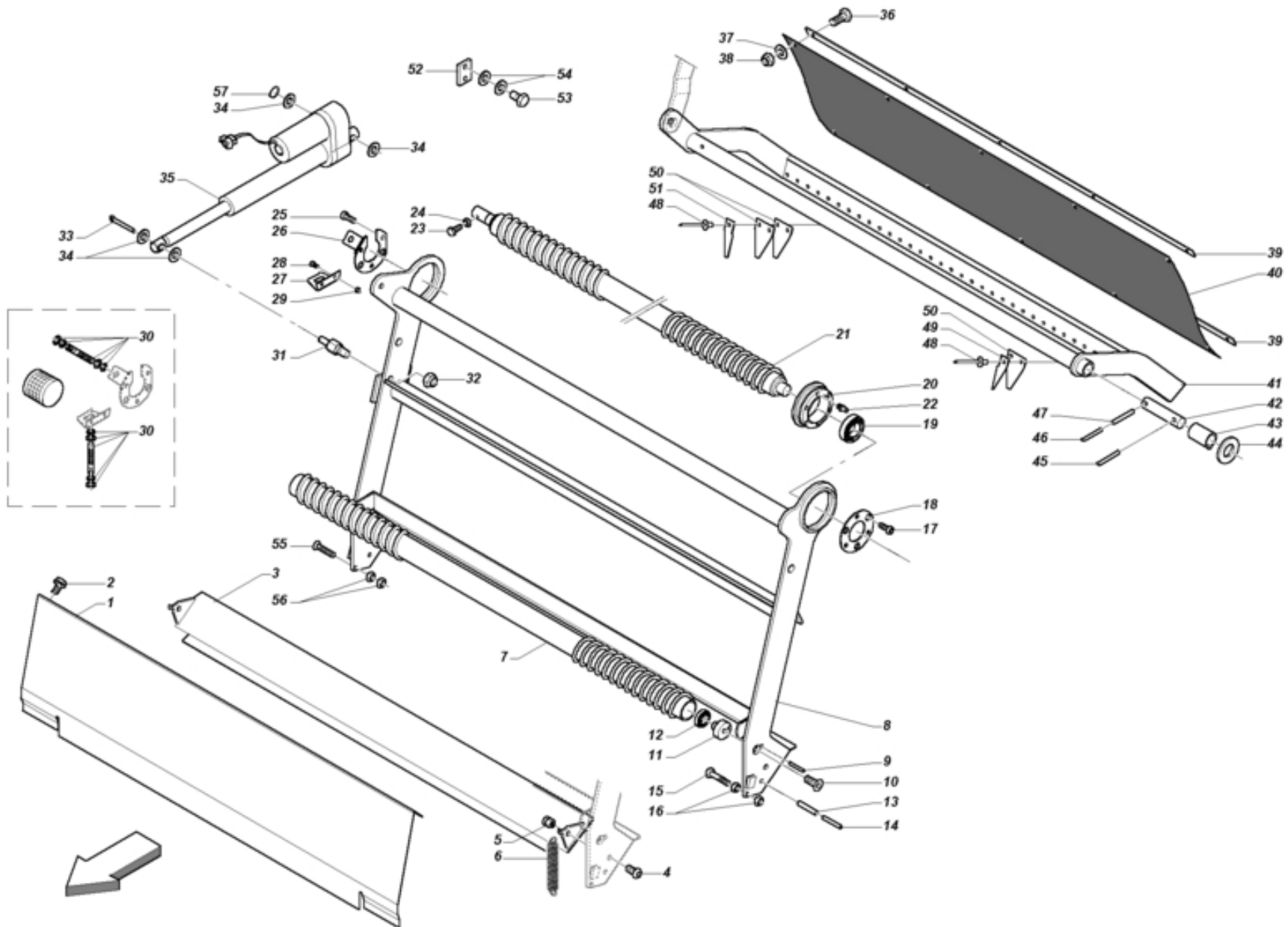

TAV_P000032_00-2

Item	Part Num.	Description	Item	Part Num.	Description
p001	C005306	NET HOLDER PROTECTION	p024	0710208	NUT
p002	0370001	SCREW	p025	0400825	SCREW
p003	7S00627	PILERS	p026	C004932	PLATE
p004	0471020	SCREW	p027	C005200	NET SENSOR COUPLING
p005	1300401	PIN WITHOUT NET	p028	0180620	SCREW
p006	1800040	SPRING	p029	0920106	NUT
p007	7S00648	IDLE ROLLER	p030	E000056	PROXIMITY SENSOR
p008	7S01810	HOSE GUIDE ARM	p031	3500063	ECCENTRIC PIN
p009	1110612	PIN	p032	0920516	NUT
p010	0441020	SCREW	p033	1150330	GALV PIN
p011	35P0008	NEW IDLE ROLLER PIN	p034	1421230	WASHER
p012	2301716	BEARING	p035	E000045	ACTUATOR
p013	1110820	PIN	p036	0180620	SCREW
p014	1110520	PIN	p037	1420615	WASHER
p015	0180835	SCREW	p038	0920106	NUT
p016	0710208	NUT	p039	C002398	RUBBERHOLDER
p017	0400825	SCREW	p040	7V00062	RUBBER CLOSING
p018	1300389	FLANGE	p041	7S01059	BLADE ARM
p019	2042517	BEARING	p042	1300390	ARM LEFT PIN
p020	2700044	NET AND ROLLER ARM SUPPORT	p043	2526852	NYLON BUSH
p021	7S00649	NET COUNTER ROLLER	p044	1522663	SHIM
p022	4200820	GREASE NIPPLE	p045	1110840	PIN
p023	0180825	SCREW	p046	1110840	PIN

TAV_P000032_00-2

Item	Part Num.	Description	
p047	1110540	PIN	
p048	1000013	RIVET	
p049	7U00018	LEFT HALF BLADE	
p050	7U00012	SMALL BLADE	
p051	7U00017	RIGHT HALF BLADE	
p052	C002039	ADJUSTER LOCK	
p053	0181015	SCREW	
p054	1421025	WASHER	
p055	0440830	SCREW	
p056	0710208	NUT	
p057	1700012	SEEGER RING	

TAV_P000033_00

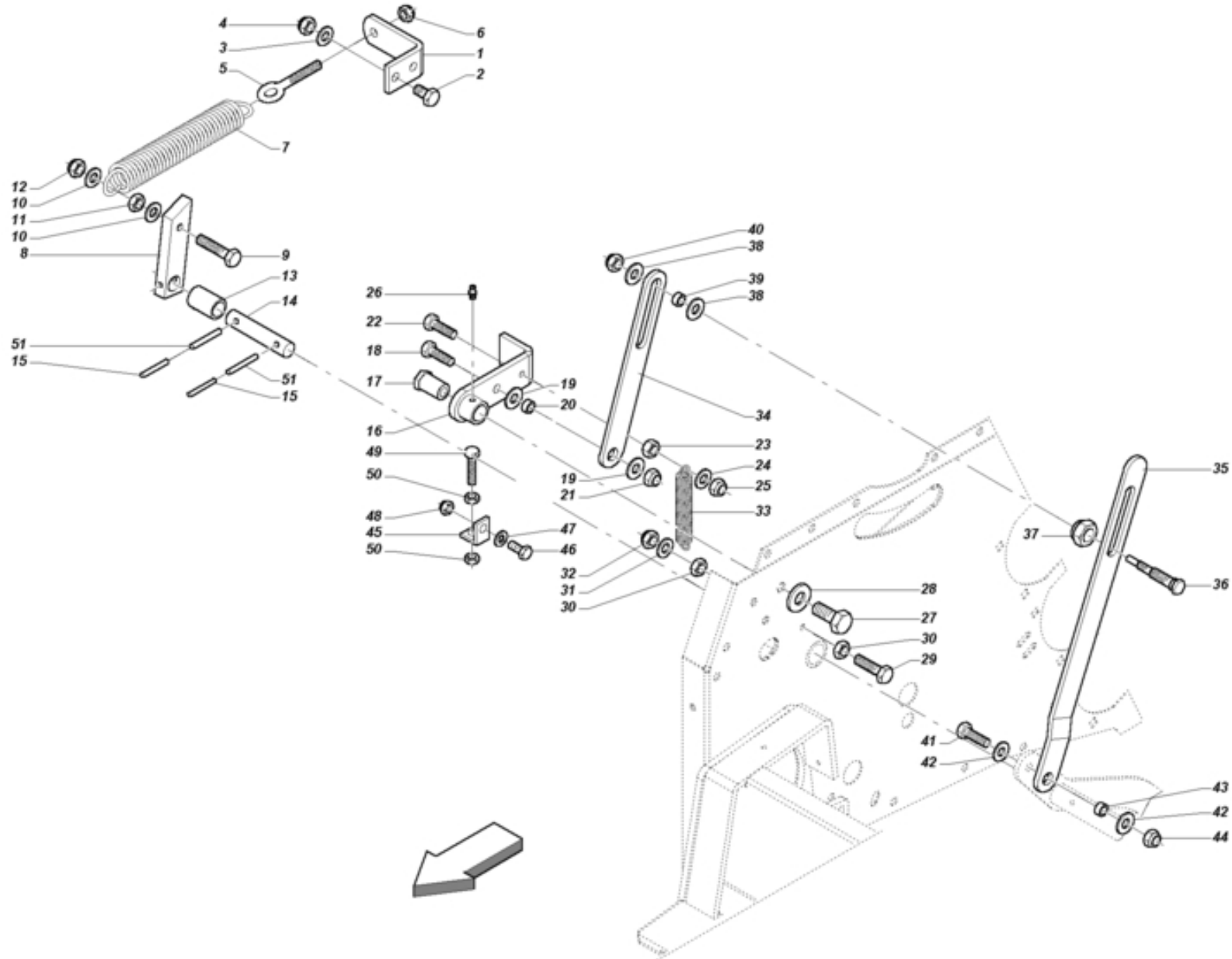

Item	Part Num.	Description	Item	Part Num.	Description
p001	C004924	ACTUATOR ATTACHMENT	p024	1420820	WASHER
p002	0181225	SCREW	p025	0920208	NUT
p003	1421230	WASHER	p026	4200610	GREASE NIPPLE
p004	0920412	NUT	p027	0181630	SCREW
p005	0545168	EYELET M12	p028	1519319	FIFTH WHEEL
p006	0920412	NUT	p029	0180825	SCREW
p007	1822744	SPRING	p030	0710208	NUT
p008	C002073	BLADE UNLOCK	p031	1420820	WASHER
p009	0181260	SCREW	p032	0920208	NUT
p010	1421230	WASHER	p033	1800025	SPRING
p011	0710412	NUT	p034	C002081	BLADE UNLOCK LEVER
p012	0920412	NUT	p035	C002043	BLADE CONNECTION
p013	2526852	NYLON BUSH	p036	1301103	BLADE PIN
p014	1301055	PIN	p037	0920516	NUT
p015	1110540	PIN	p038	1431225	WASHER
p016	7T00026	RELEASE	p039	1300463	BUSH
p017	0500093	THREADED PIN	p040	0920412	NUT
p018	0181240	SCREW	p041	0181235	SCREW
p019	1431225	WASHER	p042	1431225	WASHER
p020	1300463	BUSH	p043	1300463	BUSH
p021	0920412	NUT	p044	0920412	NUT
p022	0180830	SCREW	p045	C000053	KNIVES STOP
p023	0710208	NUT	p046	0181030	SCREW



TAV_P000033_00

Item	Part Num.	Description	
p047	1421025	WASHER	
p048	0545790	SELF-LOCKING NUT	
p049	0181060	SCREW	
p050	0710310	NUT	
p051	1110840	PIN	

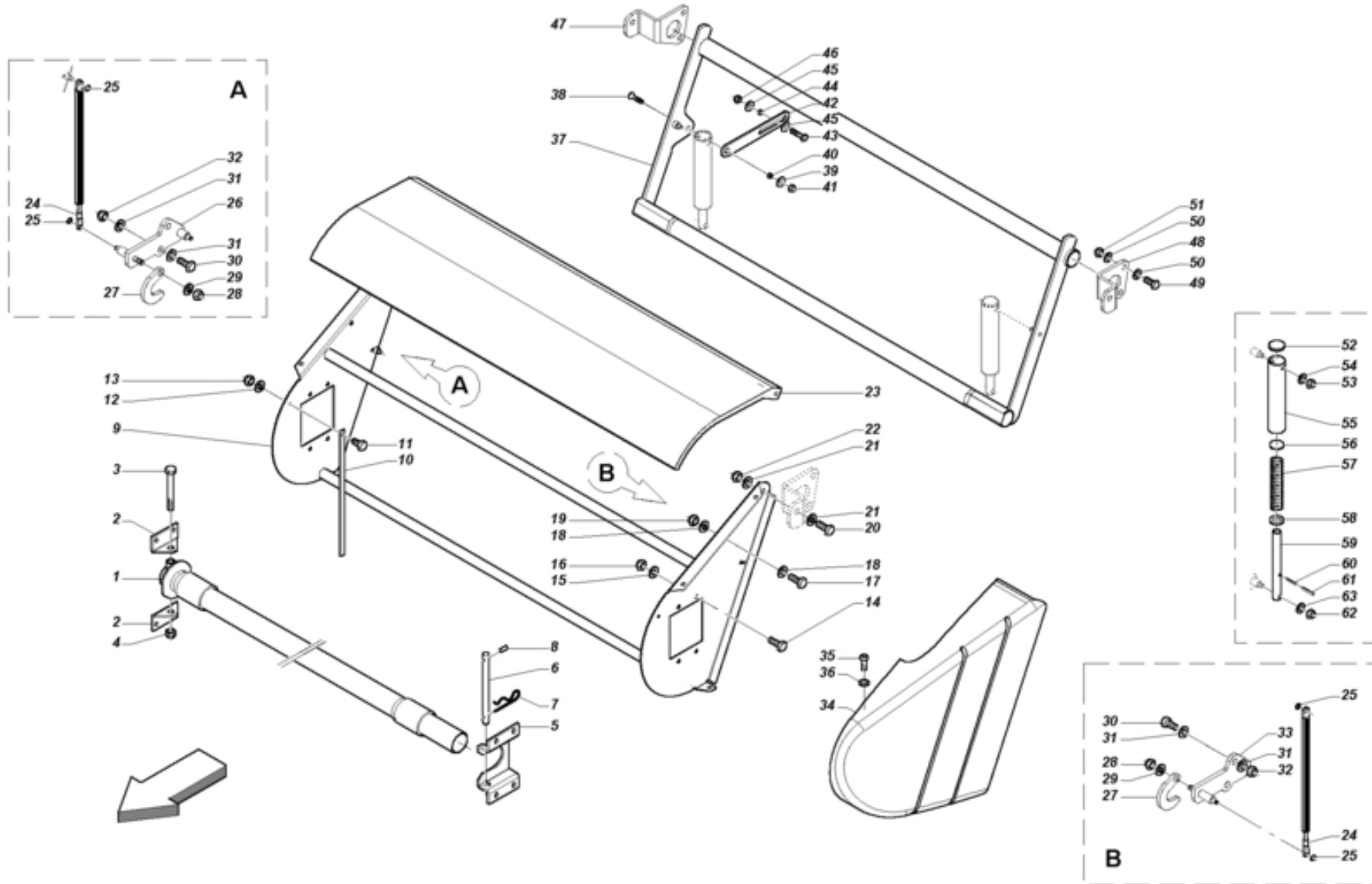

Item	Part Num.	Description	Item	Part Num.	Description
p001	7S00629	ROLLER HOLDER TUBE	p024	H100001	GAS SPRING FOR NET L=500-600N
p002	C100035	FULCRUM ATTACHMENT	p025	1700008	SEEGER RING
p003	0191694	SCREW	p026	7T00011	RIGHT BRAKE ATTACHMENT
p004	0920516	NUT	p027	C004911	HOOK
p005	C100036	TUBE SEAT	p028	0545790	SELF-LOCKING NUT
p006	1300373	PIPE PIN	p029	1421025	WASHER
p007	1170377	PIN	p030	0181230	SCREW
p008	1110435	PIN	p031	1421230	WASHER
p009	7T00001	NET STORAGE BOX	p032	0920412	NUT
p010	C005257	COVER SUPPORT	p033	7T00010	LEFT BRAKE ATTACHMENT
p011	0180620	SCREW	p034	7V00110	LEFT NET BOX
p012	1420615	WASHER	p034	7V00111	RIGHT NET BOX
p013	0920106	NUT	p035	04N0820	SCREW
p014	0181025	SCREW	p036	7V00119	WASHER HD 8,5X24X2
p015	1421025	WASHER	p037	7T00012	NET BRAKE ARM
p016	0545790	SELF-LOCKING NUT	p038	0441240	SCREW
p017	0181030	SCREW	p039	1431225	WASHER
p018	1421025	WASHER	p040	1300463	BUSH
p019	0545790	SELF-LOCKING NUT	p041	0920412	NUT
p020	0181030	SCREW	p042	C100051	BRAKE CONNECTON
p021	1421025	WASHER	p043	0181260	SCREW
p022	0545790	SELF-LOCKING NUT	p044	1300463	BUSH
p023	7T00005	CAP	p045	1431225	WASHER

Item	Part Num.	Description	
p046	0920412	NUT	
p047	C100047	BRAKE FULCRUM / RIGHT BOX	
p048	C100048	BRAKE FULCRUM / LEFT BOX	
p049	0181225	SCREW	
p050	1421230	WASHER	
p051	0920412	NUT	
p052	7V00118	PLASTIC PLUG	
p053	0920412	NUT	
p054	1421230	WASHER	
p055	1301079	EXTERNAL GUIDE	
p056	1301081	DISC 36X5	
p057	1800046	SPRING	
p058	1301082	FIFTH WHEEL	
p059	1301078	LOWER GUIDE	
p060	1110535	PIN	
p061	1110835	PIN	
p062	0920412	NUT	
p063	1421230	WASHER	

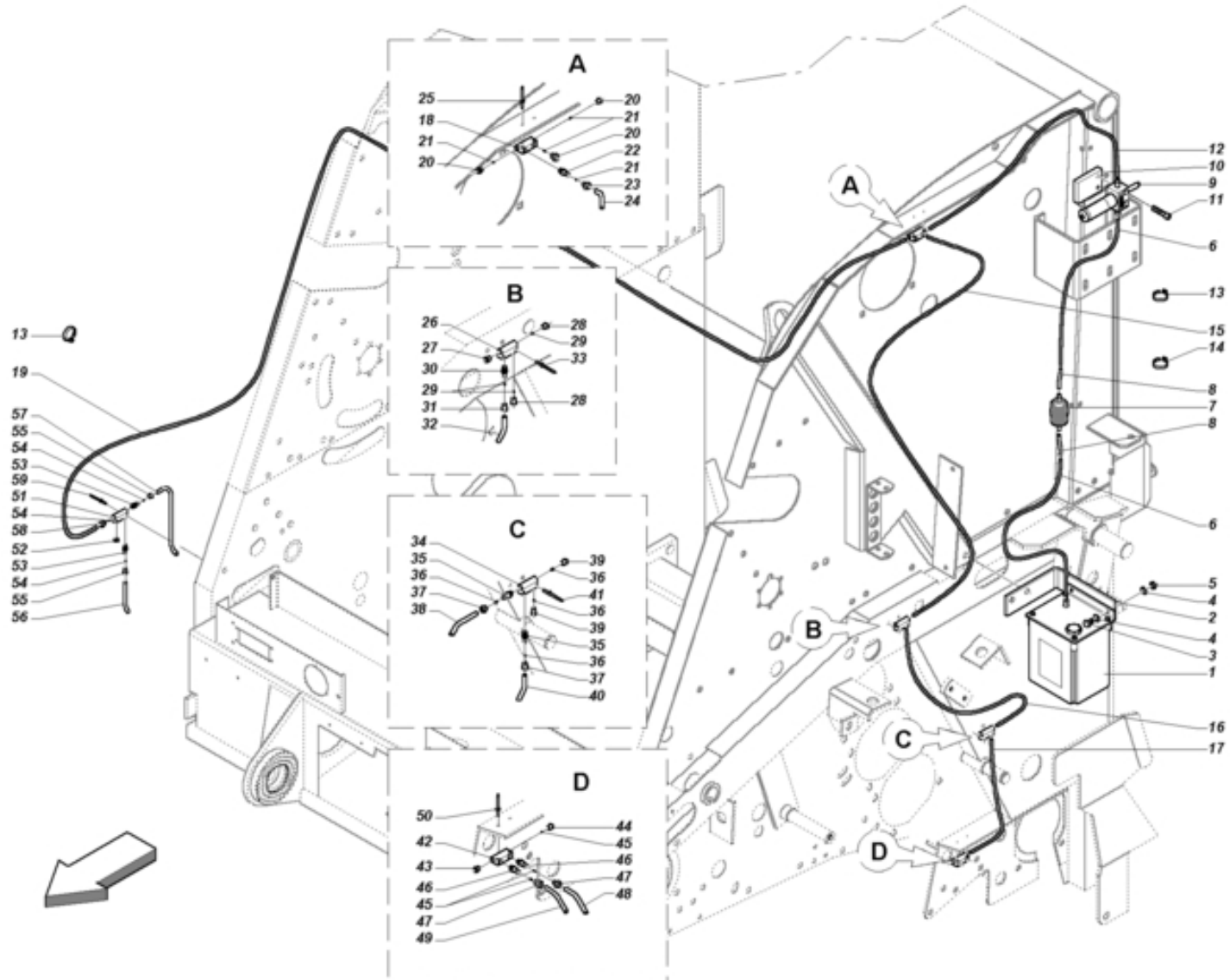

Item	Part Num.	Description	Item	Part Num.	Description
p001	4800000	NYLON TANK	p024	H000128	COPPER PIPE Ø4 L=1
p002	C004684	TANK ATTACHMENT	p025	1000012	RIVET
p003	0180620	SCREW	p026	H000102	UNILATERAL DISTRIBUTOR
p004	1420615	WASHER	p027	H600015	PLUG
p005	0920106	NUT	p028	H600016	UNION FOR PIPE Ø4RI
p006	H000239	NYLON HOSE	p029	H600013	DOUBLE CONE FOR PIPE
p007	H000022	FILTER MAXIFIS	p030	HE00003	TYPE E INJECTOR
p008	H000023	CONNECTION PIPE	p031	H600014	INJECTOR UNION FOR PIPE
p009	H400007	PISTON PUMPT	p032	H000129	COPPER PIPE Ø4 L=9
p010	C003928	LUBRICATION ATTACHMENT	p033	1000012	RIVET
p011	0400850	SCREW	p034	H000102	UNILATERAL DISTRIBUTOR
p012	H000132	NYLON PIPE Ø4 L=750	p035	HE00003	TYPE E INJECTOR
p013	E600021	CLAMP LUMEFIX	p036	H600013	DOUBLE CONE FOR PIPE
p014	E600026	CLAMP 8,8X9,3 HLS/A/HILLS	p037	H600014	INJECTOR UNION FOR PIPE
p015	H000240	NYLON HOSE	p038	H000128	COPPER PIPE Ø4 L=1
p016	H000134	NYLON PIPE Ø4 L=550	p039	H600016	UNION FOR PIPE Ø4RI
p017	H000133	NYLON PIPE Ø4 L=420	p040	H000129	COPPER PIPE Ø4 L=9
p018	H000102	UNILATERAL DISTRIBUTOR	p041	1000012	RIVET
p019	H000241	NYLON HOSE	p042	H000102	UNILATERAL DISTRIBUTOR
p020	H600016	UNION FOR PIPE Ø4RI	p043	H600015	PLUG
p021	H600013	DOUBLE CONE FOR PIPE	p044	H600016	UNION FOR PIPE Ø4RI
p022	HE00003	TYPE E INJECTOR	p045	H600013	DOUBLE CONE FOR PIPE
p023	H600014	INJECTOR UNION FOR PIPE	p046	HE00003	TYPE E INJECTOR

Item	Part Num.	Description	
p047	H600014	INJECTOR UNION FOR PIPE	
p048	H000129	COPPER PIPE Ø4 L=9	
p049	H000131	COPPER PIPE Ø4 L=1	
p050	1000012	RIVET	
p051	H000102	UNILATERAL DISTRIBUTOR	
p052	H600015	PLUG	
p053	HE00003	TYPE E INJECTOR	
p054	H600013	DOUBLE CONE FOR PIPE	
p055	H600014	INJECTOR UNION FOR PIPE	
p056	H000128	COPPER PIPE Ø4 L=1	
p057	H000130	COPPER PIPE Ø4 L=1	
p058	H600016	UNION FOR PIPE Ø4RI	
p059	1000012	RIVET	

TAV_P00037_01

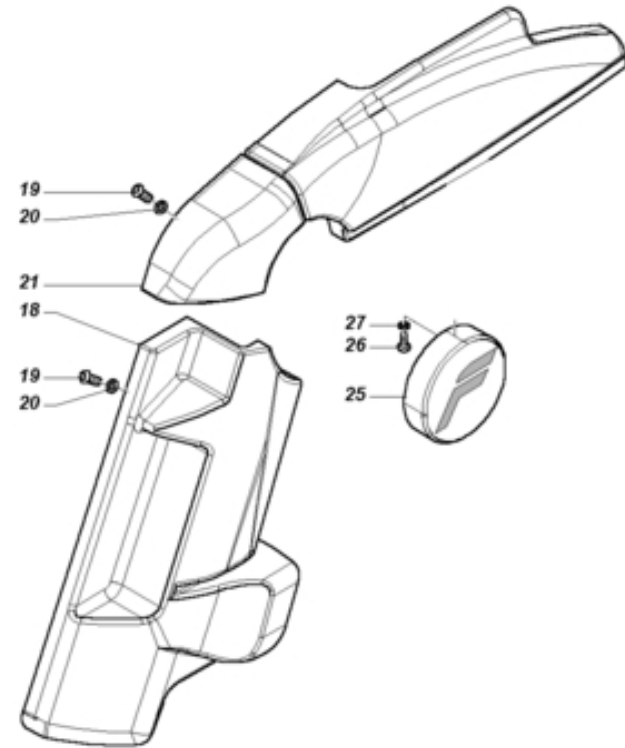
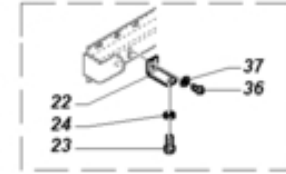
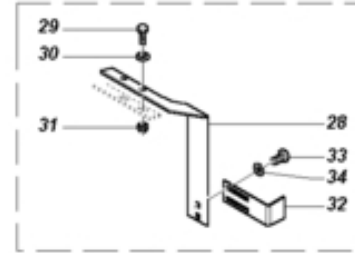
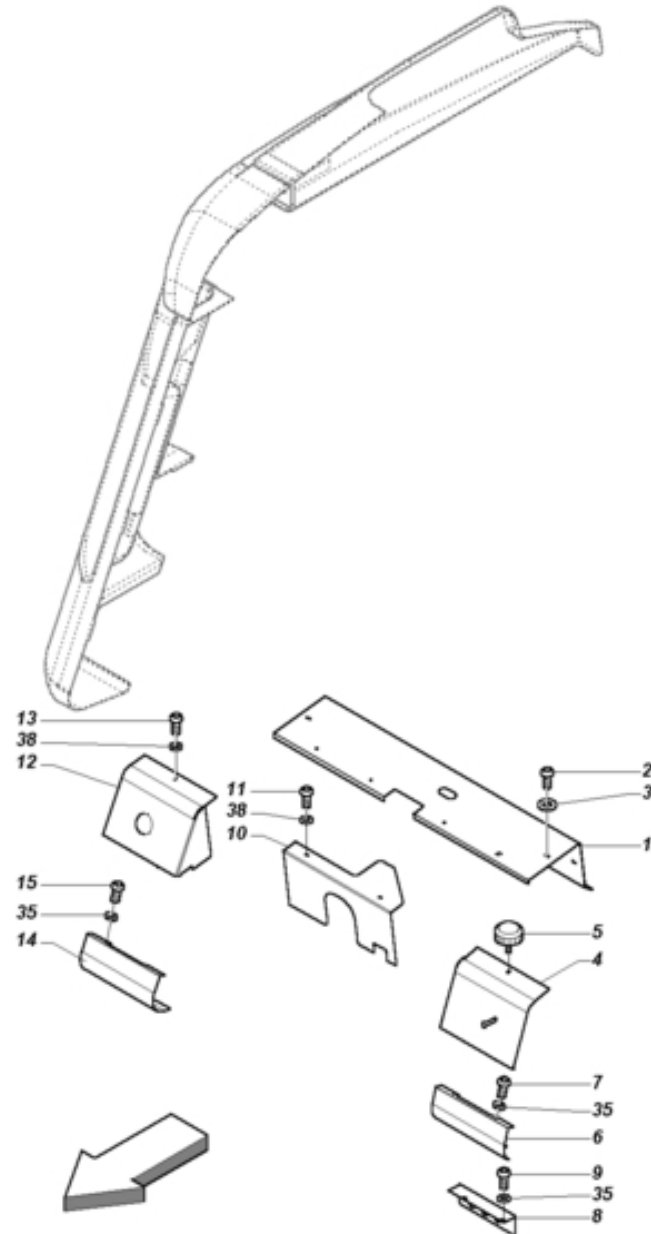
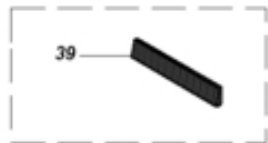
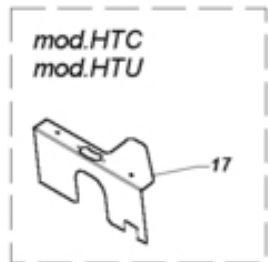
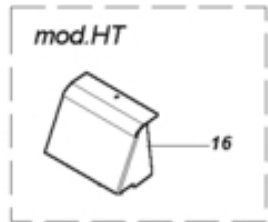

TAV_P000037_01

Item	Part Num.	Description	Item	Part Num.	Description
p001	C004454	HIGHER PROTECTION	p022	C005196	UPPER GUARD SUPPORT
p002	0470820	SCREW	p023	04N0820	SCREW
p003	1430820	WASHER	p024	1420820	WASHER
p004	C004632	DOOR	p025	7V00104	BUTTON
p005	7V00106	KNOB WHEEL	p026	0180520	SCREW
p006	C005254	LEFT LOWER CLOSURE	p027	1430520	WASHER
p007	0470620	SCREW	p028	C004425	RIGHT REGULATOR SUPPORT
p008	C004370	LOWER CLOSURE	p028	C004424	LEFT REGULATOR SUPPORT
p009	0470620	SCREW	p029	0190835	SCREW
p010	C004952	CENTRAL GUARD	p030	1420820	WASHER
p011	0470815	SCREW	p031	0920208	NUT
p012	C004958	RIGHT DOOR	p032	C004372	SIDE GUARD ADJUSTING DEVICE
p013	0470815	SCREW	p033	0180830	SCREW
p014	C004622	RIGHT LOWER CLOSURE	p034	1420820	WASHER
p015	0470620	SCREW	p035	1420615	WASHER
p016	C005160	RIGHT DOOR WITHOUT HOLE	p036	04N0820	SCREW
p017	C004626	CUT CENTRAL GUARD	p037	1420820	WASHER
p018	7V00103	LEFT FRONT EDGE	p038	1430820	WASHER
p018	7V00102	RIGHT FRONT EDGE	p039	7VP0011	HOLE PROTECTION
p019	04N0820	SCREW			
p020	7V00119	WASHER HD 8,5X24X2			
p021	7V00101	LEFT CAP 265			
p021	7V00100	RIGHT CAP 265			

TAV_P000040_01

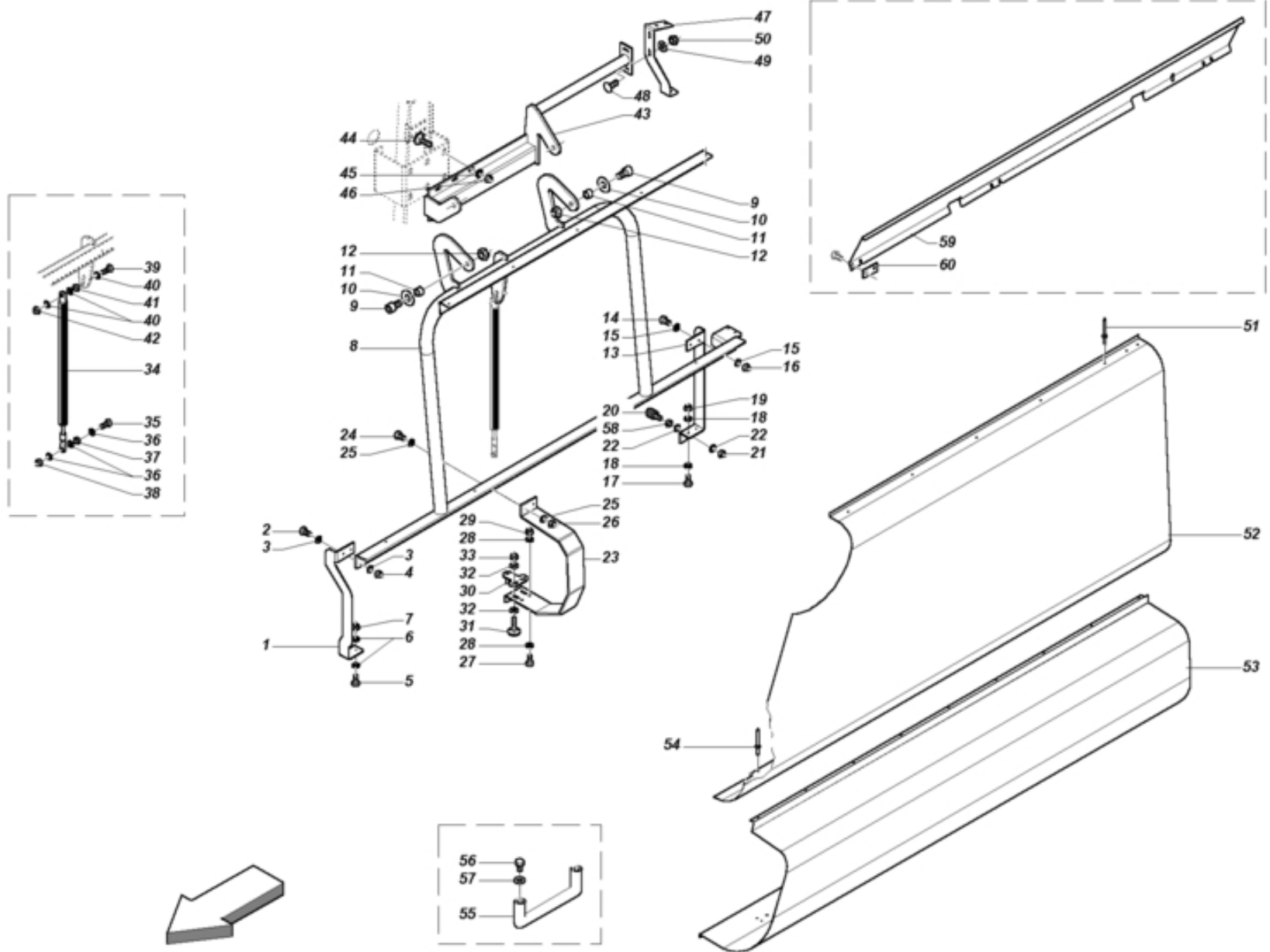

TAV_P000040_01

Item	Part Num.	Description	Item	Part Num.	Description
p001	C005009	LEFT FRONT SUPPORT	p021	0920208	NUT
p001	C005010	RIGHT FRONT SUPPORT	p022	1420820	WASHER
p002	0180625	SCREW	p023	C100002	CENTRAL SUPPORT
p003	1420615	WASHER	p024	0180625	SCREW
p004	0920106	NUT	p025	1420615	WASHER
p005	0180620	SCREW	p026	0920106	NUT
p006	1420615	WASHER	p027	0180620	SCREW
p007	0920106	NUT	p028	1420615	WASHER
p008	7S01614	HT LEFT GUARD FRAME	p029	0920106	NUT
p008	7S01615	HT RIGHT GUARD FRAME	p030	7S01850	CLOSURE CONNECTION
p009	0401240	SCREW	p031	0320825	SCREW
p010	1431225	WASHER	p032	1430820	WASHER
p011	1300463	BUSH	p033	0920208	NUT
p012	0920412	NUT	p034	H100003	GAS SPRING 1900N
p013	C004693	RIGHT UPPER SUPPORT	p035	0191050	SCREW
p013	C004692	LEFT UPPER SUPPORT	p036	1421025	WASHER
p014	0180625	SCREW	p037	0710310	NUT
p015	1420615	WASHER	p038	0545790	SELF-LOCKING NUT
p016	0920106	NUT	p039	0191050	SCREW
p017	0180620	SCREW	p040	1421025	WASHER
p018	1420615	WASHER	p041	0710310	NUT
p019	0920106	NUT	p042	0545790	SELF-LOCKING NUT
p020	1800082	RUBBER BUSHING Ø30X30-M8X20	p043	7S01613	LEFT GUARD HINGE CONNECTION

Item	Part Num.	Description	
p043	7S01767	RIGHT GUARD HINGE COUPLING	
p044	0523421	SPECIAL SCREW	
p045	1421230	WASHER	
p046	0920412	NUT	
p047	C005040	RIGHT CAP SUPPORT	
p047	C005039	CAP LEFT SUPPORT	
p048	0320825	SCREW	
p049	1430820	WASHER	
p050	0920208	NUT	
p051	1000010	RIVET	
p052	C004650	RIGHT CARTER BODY 265	
p052	C004649	LEFT CARDER BODY 265	
p053	C004694	LEFT ROLLER BOX 265	
p053	C004695	RIGHT ROLLER BOX 265	
p054	1000011	RIVET	
p055	7V00117	HANDLE 01M20120D (FROM THENAR COMP)	
p056	0180815	SCREW	
p057	1420820	WASHER	
p058	0710208	NUT	
p059	C3P0042	GUARD LEFT INNER PROTECTION	
p059	C3P0043	SIDE GUARD 265-280 RIGHT INNER PROT	
p060	C6P0112	INNER PROTECTION SUPPORT	

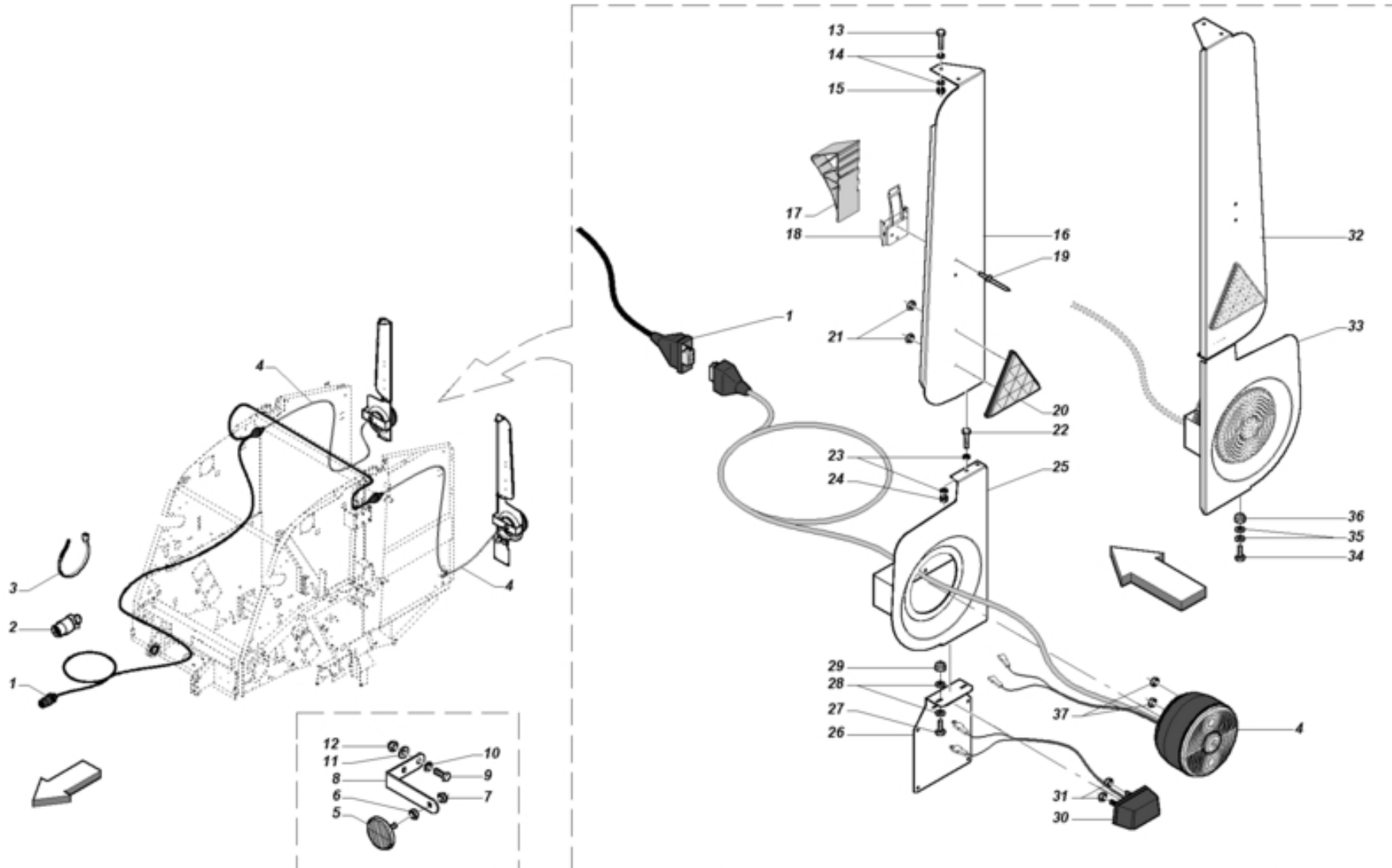

Item	Part Num.	Description	Item	Part Num.	Description
p001	E000137	7-POLES PLUG AND WIRING HARNESS	p024	0920106	NUT
p002	E000011	7 POLE PLUG 12 V	p025	7S01635	LEFT LIGHT ATTACHMENT
p003	E600021	CLAMP LUMEFIX	p026	C005037	PLATE HOLDER
p004	E000136	EXTREME BACK LAMP	p027	0180620	SCREW
p005	E000026	WHITE ROUND RETROREFLECTOR	p028	1420615	WASHER
p006	0710005	NUT	p029	0920106	NUT
p007	0920005	NUT	p030	E000138	EXTREME REAR PLATE LIGHT
p008	C6P0034	REFLEX REFLECTO SUPPORT	p031	0920005	NUT
p009	0180620	SCREW	p032	C005019	RIGHT UPPER LOCK
p010	1420615	WASHER	p033	7S01634	RIGHT LIGHT ATTACHMENT
p011	1430620	WASHER	p034	0180620	SCREW
p012	0920106	NUT	p035	1420615	WASHER
p013	0180620	SCREW	p036	0920106	NUT
p014	1420615	WASHER	p037	0920005	NUT
p015	0920106	NUT			
p016	C004999	LEFT UPPER LOCK			
p017	7V00070	WHEEL CHOCK			
p018	7V00071	CHOCK SUPPORT TYPE HA20K			
p019	1000011	RIVET			
p020	E000025	RED TRIANGULAR RETROREFLECTOR			
p021	0920106	NUT			
p022	0180625	SCREW			
p023	1420615	WASHER			

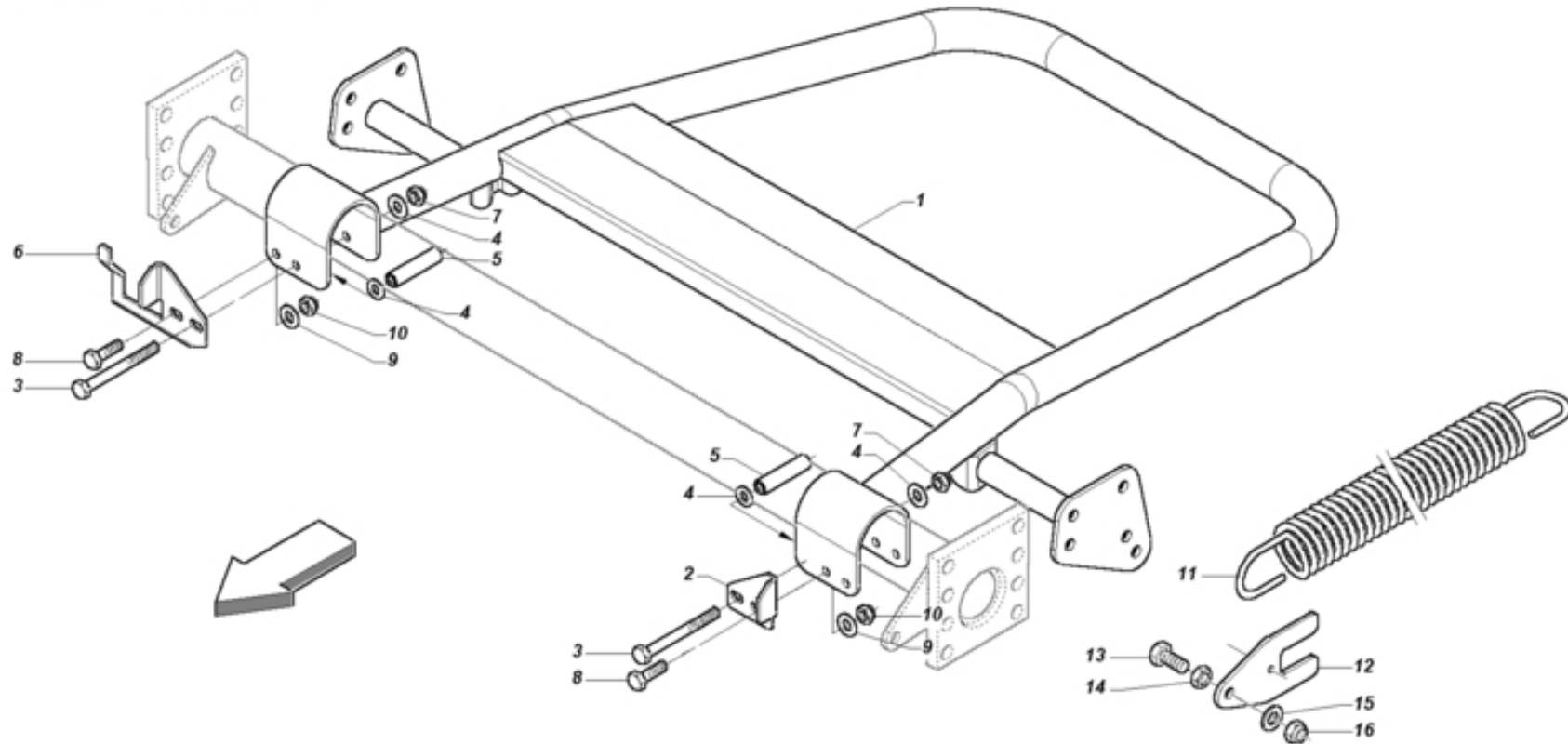
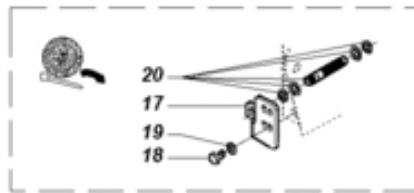

Item	Part Num.	Description	
p001	7S01806	EJECTOR	
p002	C6P0006	REGULATOR	
p003	0191295	SCREW	
p004	1421230	WASHER	
p005	1301061	SPACER	
p006	C6P0005	COUNTER SENSOR	
p007	0920412	NUT	
p008	0181230	SCREW	
p009	1421230	WASHER	
p010	0920412	NUT	
p011	1800090	SPRING	
p012	C6P0113	EJECTOR PLATE	
p013	0181650	SCREW	
p014	0710516	NUT	
p015	1421630	WASHER	
p016	0920516	NUT	
p017	C6P0004	EJECTOR SENSOR COUPLING	
p018	0180820	SCREW	
p019	1420820	WASHER	
p020	E000056	PROXIMITY SENSOR	

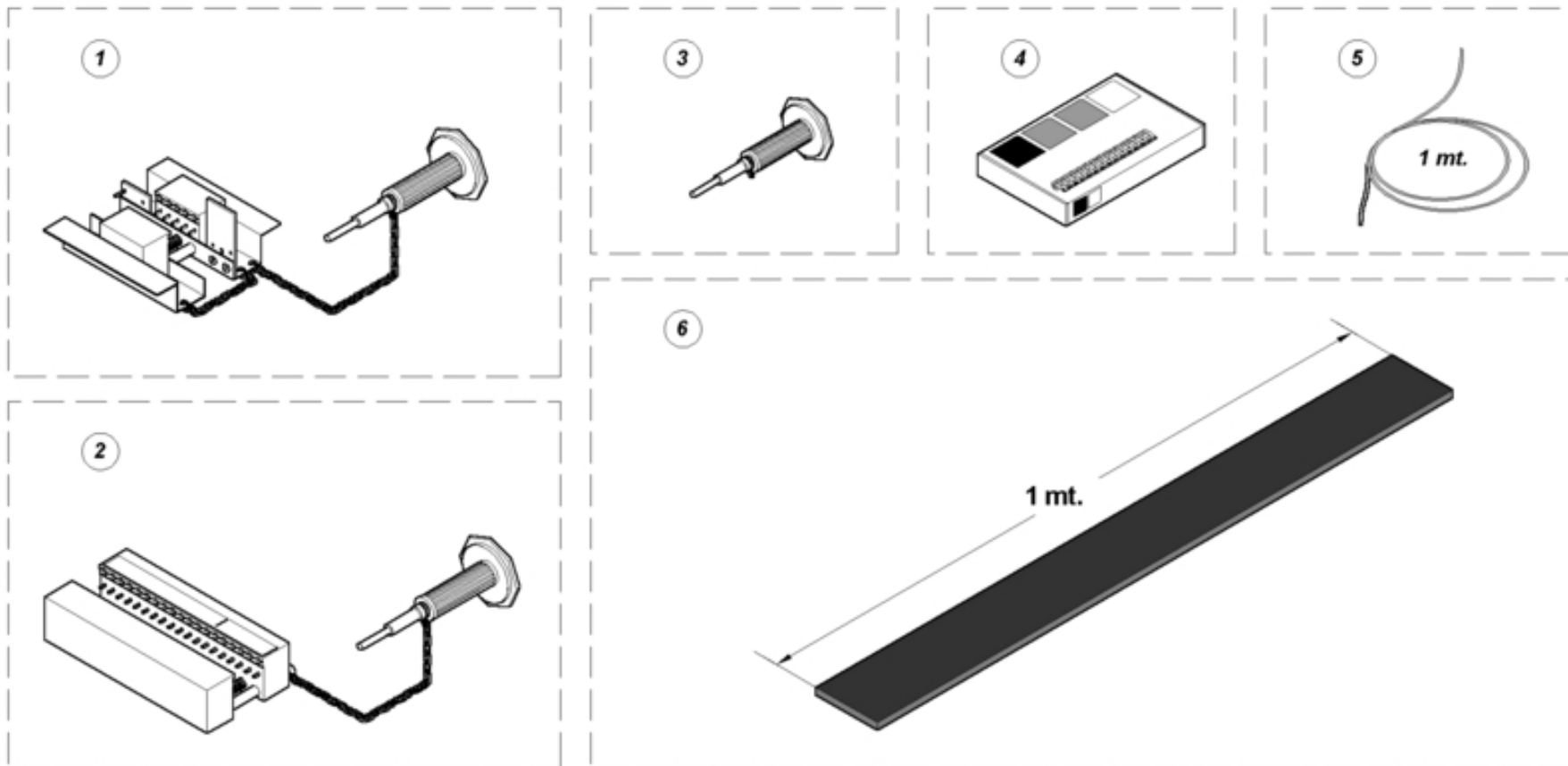



TAV_P000050_00-HT

Item	Part Num.	Description	
p001	ZAP0025	MATO PROFI 5 BELT LACER	
p002	ZAP0026	"PROFI 19" BELT LACER	
p003	7U00049	PUNCH	
p004	9940018	MATO LACINGS BOX	
p005	7600075	CONNECTING BELT	
p006	7600073	BELT (PIECE L=1000)	

TAV_P000051_01

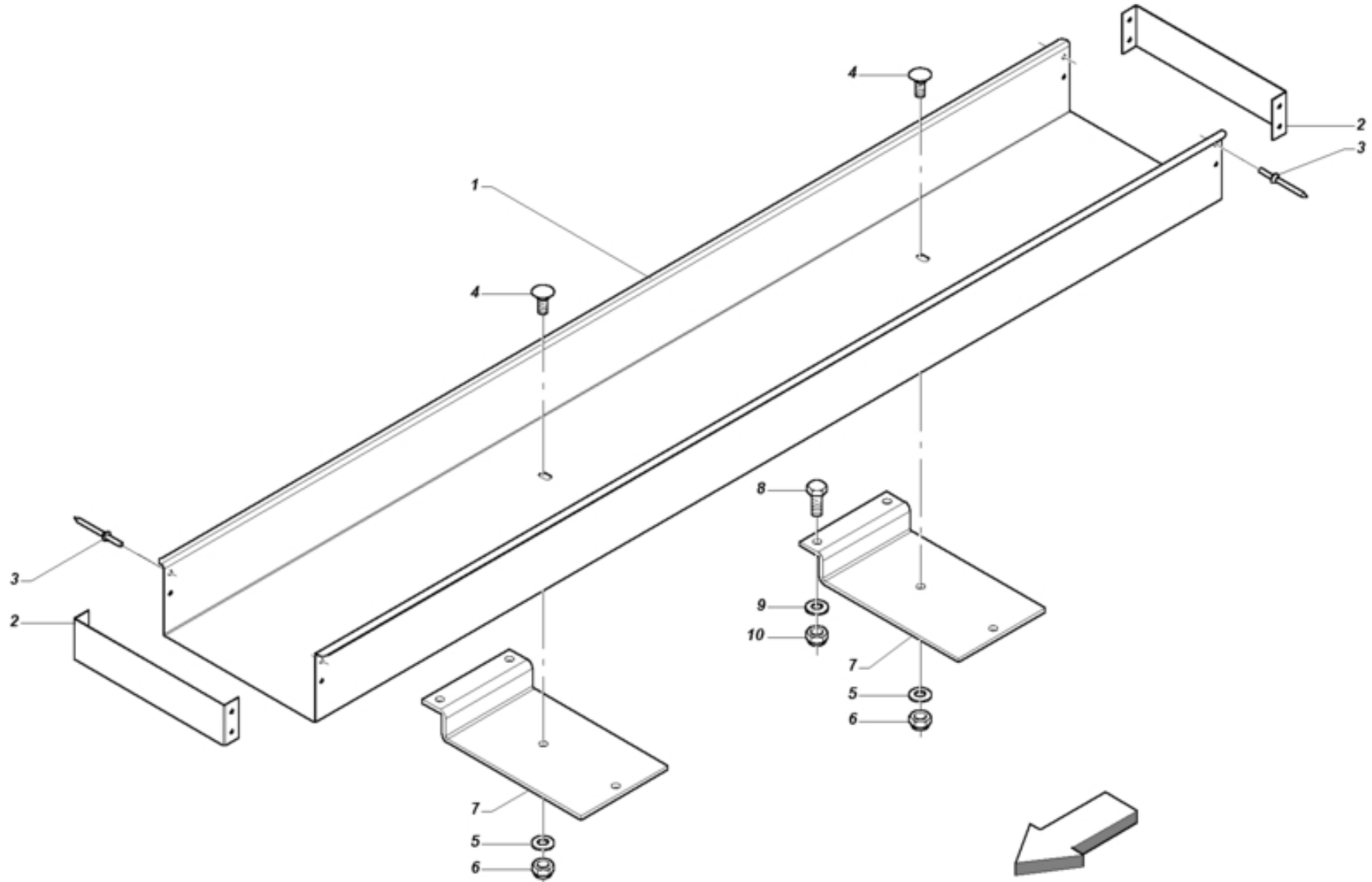

TAV_P000051_01

Item	Part Num.	Description	
p001	C005015	ADDITIONAL BOX	
p002	C005014	TERMINAL LOCK	
p003	1000010	RIVET	
p004	0321020	SCREW	
p005	1421025	WASHER	
p006	0545790	SELF-LOCKING NUT	
p007	C004685	TWINE BOX HOLDER	
p008	0181030	SCREW	
p009	1421025	WASHER	
p010	0545790	SELF-LOCKING NUT	

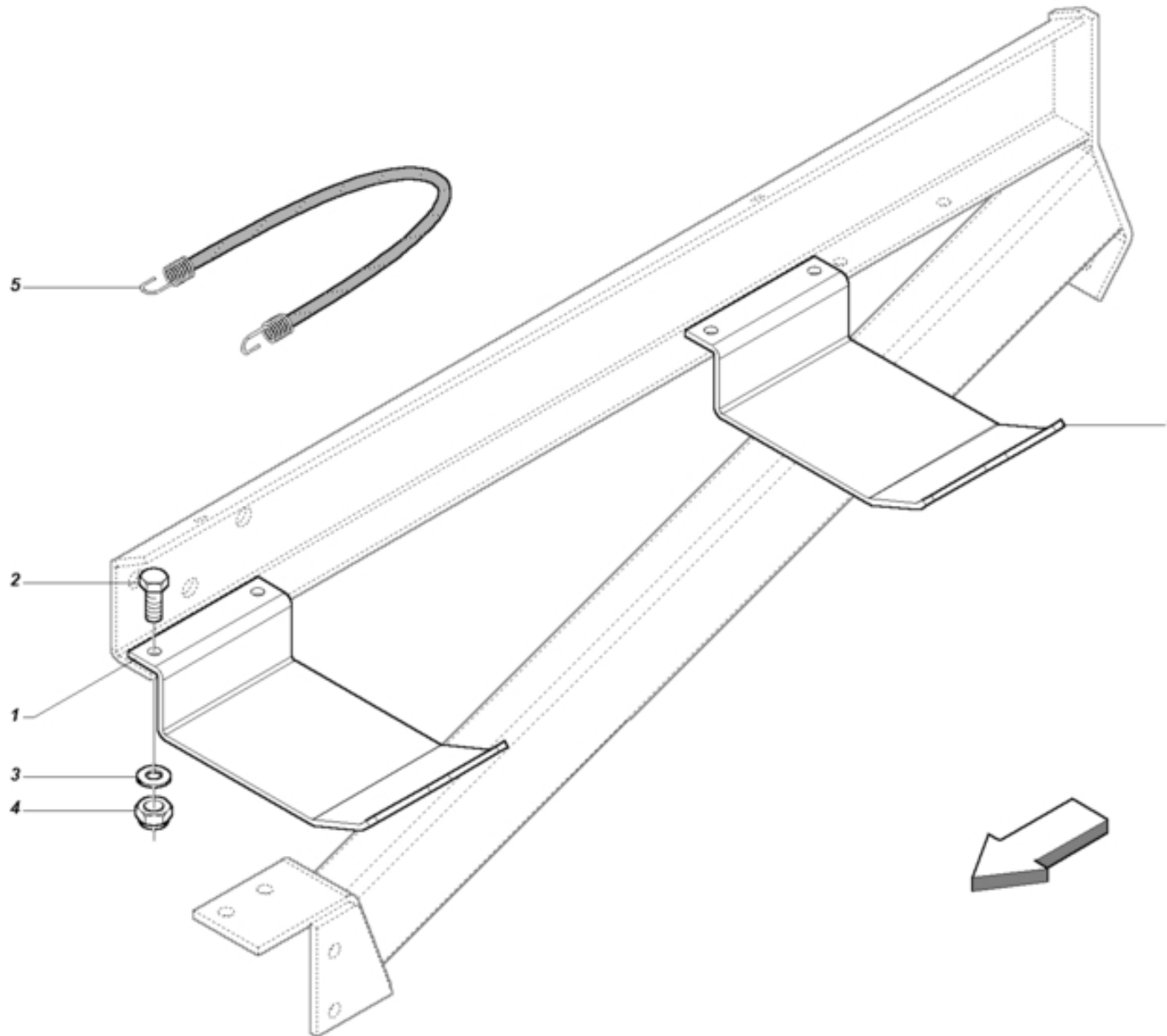

Item	Part Num.	Description	
p001	C100013	NET SUPPORT	
p002	0181030	SCREW	
p003	1421025	WASHER	
p004	0545790	SELF-LOCKING NUT	
p005	7V00107	ELASTIC CABLE WITH HOOKS	

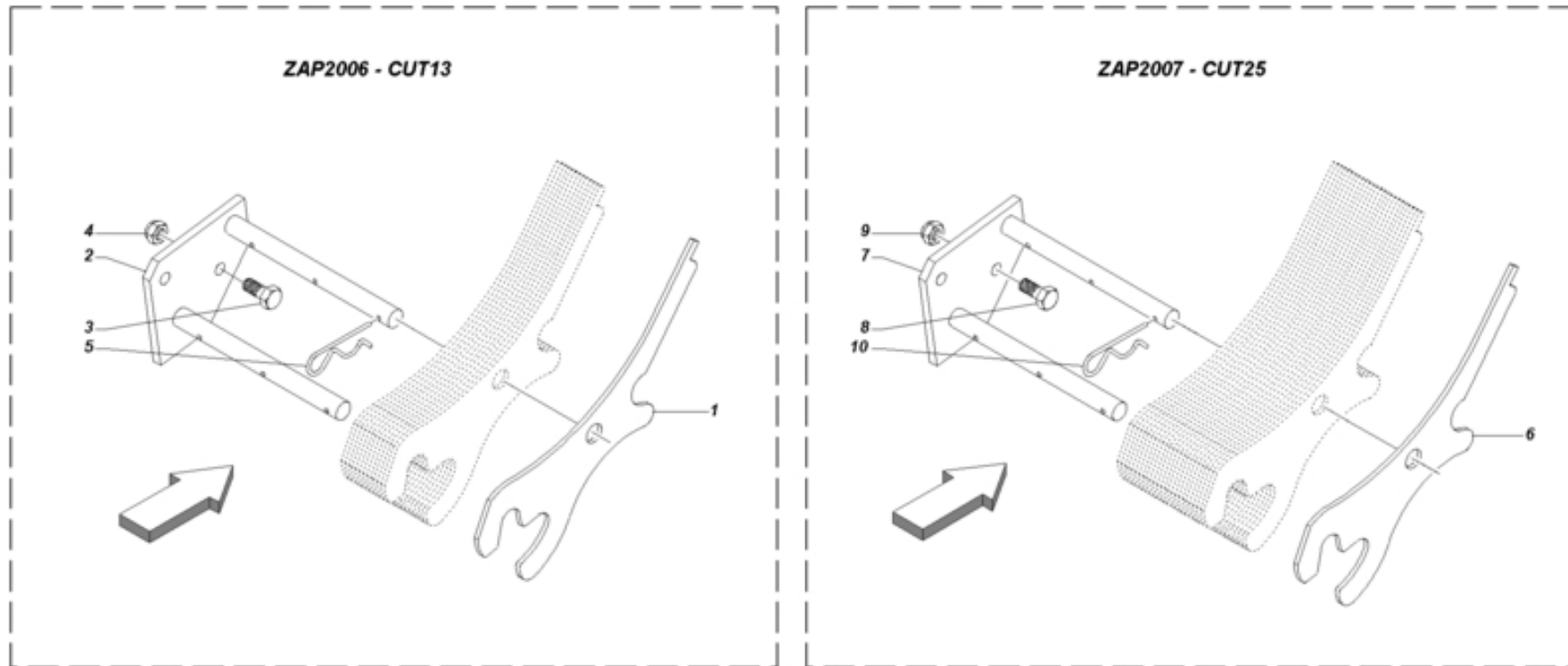

Item	Part Num.	Description	
p001	C005006	BLANK KNIFE "CUT"	
p002	7S01896	NEW KNIVES HOLDER	
p003	0181230	SCREW	
p004	0920412	NUT	
p005	1170484	PIN	
p006	C005006	BLANK KNIFE "CUT"	
p007	7S01896	NEW KNIVES HOLDER	
p008	0181230	SCREW	
p009	0920412	NUT	
p010	1170484	PIN	

TAV_P000054_00

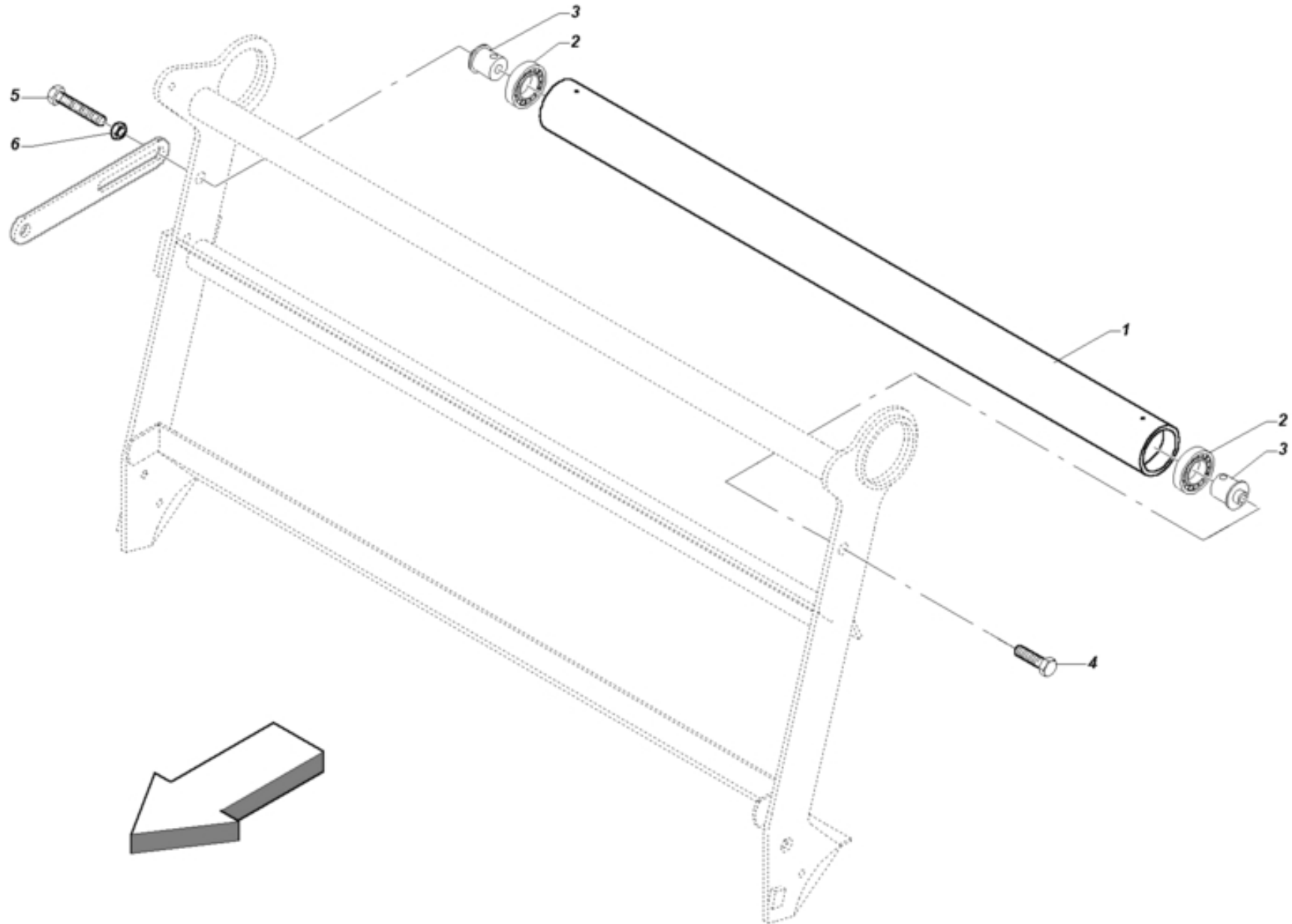



TAV_P000054_00

Item	Part Num.	Description	
p001	3500048	IDLE ROLLER	
p002	2040002	BEARING	
p003	3500047	IDLE ROLLER GUDGEON	
p004	0181235	SCREW	
p005	0181290	SCREW	
p006	0710412	NUT	

TAV_P00055_00

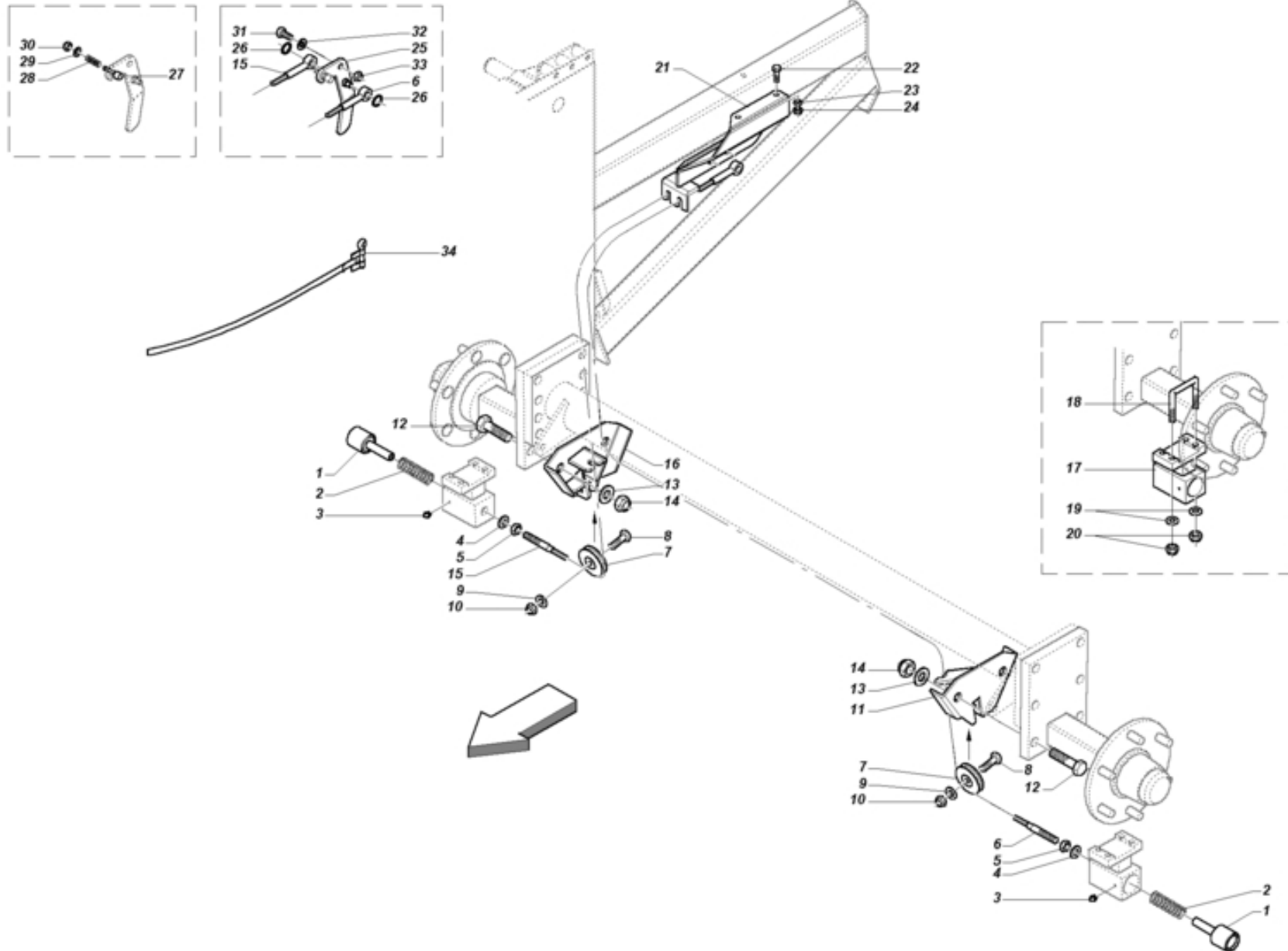

Item	Part Num.	Description	Item	Part Num.	Description
p001	13P0003	PIN	p024	0545790	SELF-LOCKING NUT
p002	1830231	SPRING	p025	7SP0007	HANDLE WITH PIN
p003	4200610	GREASE NIPPLE	p026	1700010	SEEGER RING
p004	1431020	WASHER	p027	05P0001	SAFETY PIN
p005	0710310	NUT	p028	1821993	SPRING
p006	7J00011	CONTROL CABLE DIAM. 4	p029	1430820	WASHER
p007	38P0001	PULLEY FOR ROPE	p030	0920208	NUT
p008	0191050	SCREW	p031	0191240	SCREW
p009	1421025	WASHER	p032	1421230	WASHER
p010	0545790	SELF-LOCKING NUT	p033	0920412	NUT
p011	7SP0006	LEFT PULLEY ATTACHMENT	p034	E000061	STEEL HOSE CLAMP
p012	0192060	SCREW			
p013	1422035	WASHER			
p014	0920620	NUT			
p015	7J00010	CONTROL CABLE DIAM. 4			
p016	7SP0005	RIGHT PULLEY ATTACHMENT			
p017	7SP0004	SLIDER SUPPORT			
p018	0500081	U-BOLT 60X60 M12			
p019	1421230	WASHER			
p020	0920412	NUT			
p021	7SP0008	HANDLE ATTACHMENT			
p022	0191040	SCREW			
p023	1421025	WASHER			

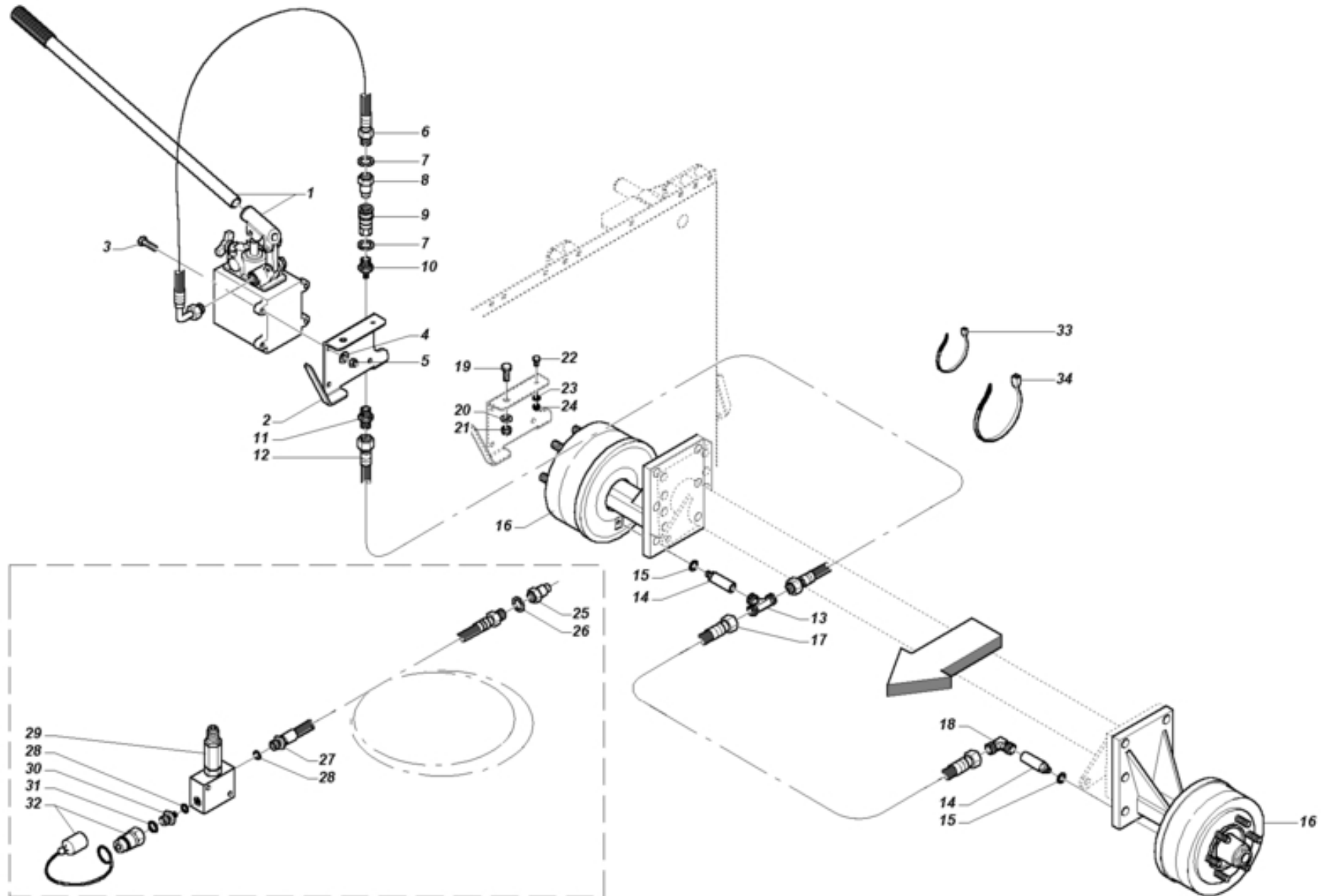

Item	Part Num.	Description	Item	Part Num.	Description
p001	H400107	HAND PUMP HPT12C	p024	0920106	NUT
p002	C4P0002	MANUAL PUMP SUPPORT	p025	H000207	FAST CLUTCH 1/4 MALE
p003	0190830	SCREW	p026	1441015	ALUMINIUM OR BRASS WASHER 10X15
p004	1420820	WASHER	p027	H0P0001	HYDRAULIC HOSE L=5500
p005	0920208	NUT	p028	1441815	WASHER
p006	H000206	HYDRAULIC HOSE WITH FITTING L=410	p029	H000143	REDUCTION VALVE
p007	1441015	ALUMINIUM OR BRASS WASHER 10X15	p030	H6000AB	NIPPLE
p008	H000207	FAST CLUTCH 1/4 MALE	p031	1442015	WASHER
p009	H000208	FAST CLUTCH 1/4 FEMALE	p032	H6000A0	QUICK CLUTCH
p010	H000284	"I" FITTING TN 126GG-10LR	p033	E600021	CLAMP LUMEFIX
p011	H000153	CONNECTION	p034	E600022	CLAMP LUMEFIX
p012	H000033	HYDR. TUBE			
p013	H000144	UNION TEE 10			
p014	H000162	FITTING SLEEVE			
p015	1441415	WASHER			
p016	7100031	HUB WITH BRAKE			
p017	H000091	FLEXIBLE TUBE SAE 100 R1AT			
p018	H000086	UNION "L"10			
p019	0181025	SCREW			
p020	1421025	WASHER			
p021	0545790	SELF-LOCKING NUT			
p022	0180625	SCREW			
p023	1420615	WASHER			



1 *Extreme*

2 *Extreme*

3 *HT*

4 *HTC*

5 *HTU*



10 FERABOLI

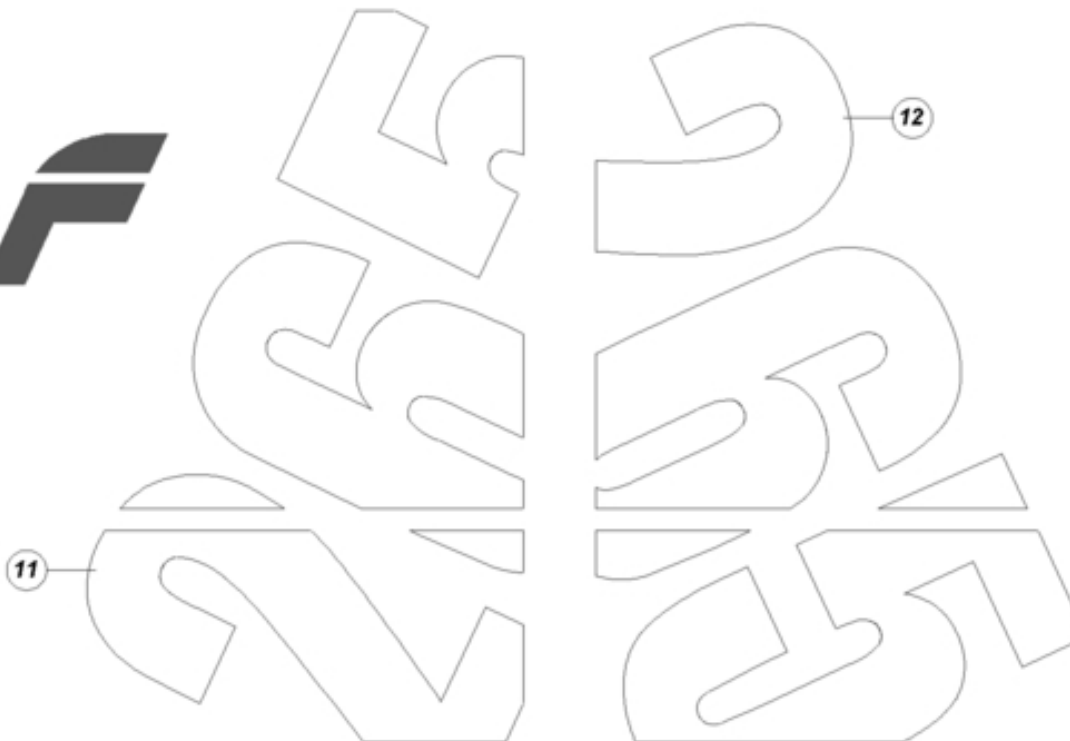



TAV_P000135_00

Item	Part Num.	Description	
p001	7500731		
p002	7500732		
p003	7500741		
p004	7500742		
p005	7500743		
p006	7500744		
p007	7500751		
p008	7500745		
p009	7500729	FERABOLI BRAND-UPPER PART	
p010	7500730	FERABOLI BRAND-LOWER PART	
p011	7500738		
p012	7500737		
p013	7500747		
p014	7500746		

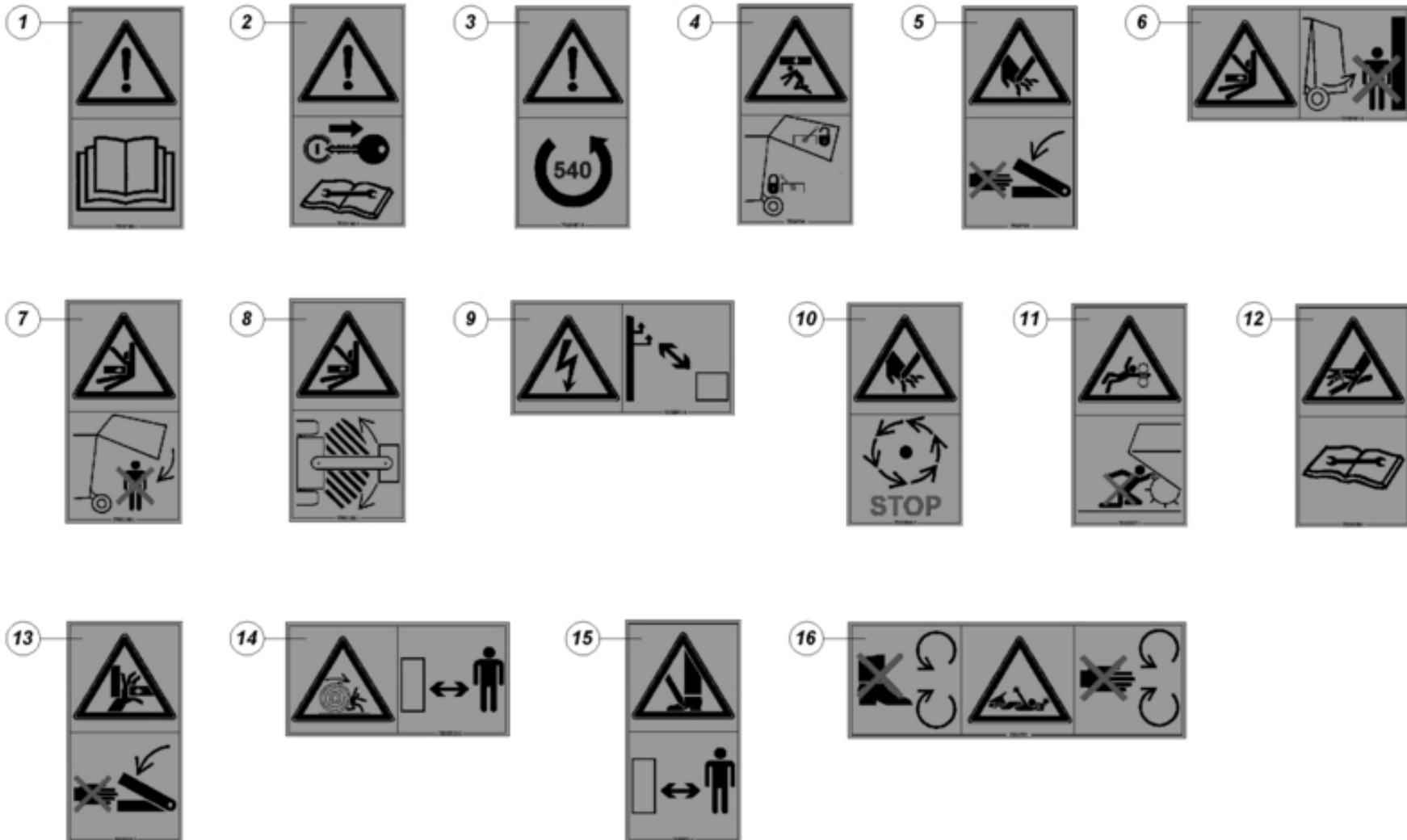

Item	Part Num.	Description	
p001	7500185	DECAL (SEE OPERATOR' S MANUAL)	
p002	7500186	DECAL "TAKE THE WRENCH AWAY"	
p003	7500187	DECAL "540RPM - LEFT BURR"	
p004	7500724		
p005	7500726		
p006	7500197	"SQUEEZED MAN " DECAL	
p007	7500198	"SQUEEZED MAN" DECAL	
p008	7500199	DECAL "SQUEEZED PERSON"	
p009	7500201	ELECTRIC SHOCK DECAL	
p010	7500203	DECAL "HAND CUT _ STOP"	
p011	7500207	"TRAPPED MAN" DECAL	
p012	7500208	DECAL "OIL UNDER PRESSURE HAND	
p013	7500210	DECAL "SQUEEZED HAND _ ORGANS"	
p014	7500212	"SQUEEZED MAN-BALE" DECAL	
p015	7500221	"WARNING CUT FEET" DECAL	
p016	7500781	"DANGER PTO SHAFT" DECAL	

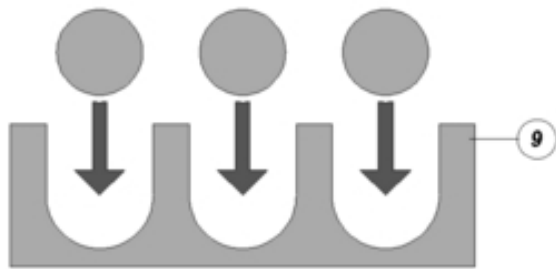

6

I IMPORTANTE NON USARE CETTI AD ELEVATE PRESSIONI VICINO ALLE PARTI MECCANICHE SI POSSONO CAUSARE DANNI.	ENG IMPORTANT DO NOT USE HIGH PRESSURE JETS NEAR MECHANICAL PARTS, AS DAMAGES CAN BE CAUSED.
F IMPORTANTE NE PAS UTILISER DES JETS A PRESSION ELEVÉE PRES DE PARTIES MECCANQUES, ON PEUT CAUSER DES DOMMAGES.	D WICHTIG HOCHDRUCKSTRAHLE NEREN MECHANISCHEN TEILEN NICHT VERWENDEN, DA SCHADEN VERURSACHT WERDEN KÖNNTEN.

T500217

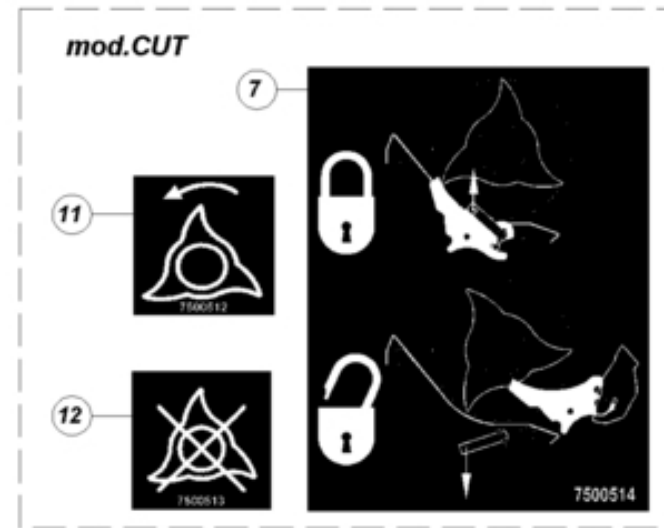
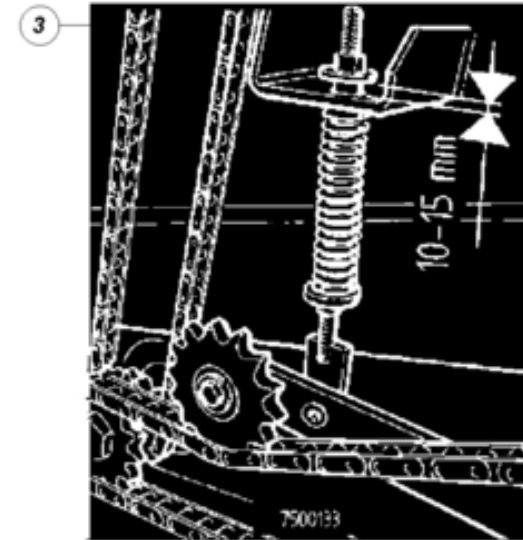

Item	Part Num.	Description	
p001	7500750		
p002	7500733		
p003	7500133	DECAL "AUTOMATIC TIGHTNER"	
p004	7500214	DECAL "GREASE SQUIRT"	
p005	7500216	DECAL "HOOK"	
p006	7500217	DECAL "DO NOT USE SPOUTS"	
p007	7500514	DECAL "KNIVES LOCK./UNBLOCK."	
p008	7500748		
p009	7500749	HYDRAULIC LINKAGE DECAL	
p010	75P0018		
p011	7500512	DECAL "ROTOR GEARSHIFT"	
p012	7500513	DECAL "IDLE ROTOR"	

**USATE SEMPRE RICAMBI ORIGINALI
ALWAYS USE ORIGINAL SPARE PARTS
IMMER DIE ORIGINAL-ERSATZTEILE VERWENDEN
EMPLOYEZ TOUJOURS LES PIECES DE RECHANGE ORIGINALES
UTILIZAR SIEMPRE REPUESTOS ORIGINALES**

FERABOLI

Servizio Assistenza Tecnica - After Sales Service

Servizio Ricambi - Spare Parts Service

+39 0372 49970

DEALER:



FERABOLI

Off. Mecc. Ing. A. FERABOLI S.p.A.
Via Bredina, 6 - 26100
Cremona - Italy
Tel. +39 0372 49970
Fax +39 0372 557850
info@feraboli.com
www.feraboli.com

FERABOLI CIS Moscow Office
Ostapovsky proezd 5 of 104/107
109316 Moscow City - Russian Federation
Tel. +7 495 7818634
Fax +7 495 7812460
info@feraboli.ru

**MASCHIO GASPARDO
Poland sp z.o.o.**
Ul. Wapienna 6/8 - 87 - 100 Torun Poland
Tel. +48 56 6506051
Fax +48 56 6506053
www.gaspardo.pl

MASCHIO FRANCE Sarl
1, Rue de Mérignan ZA
F - 45240 La Ferte St. Aubin
France
Tel. +33 (0) 2.38.64.12.12
Fax +33 (0) 2.38.64.66.79
info@maschio.fr

MASCHIO-GASPARDO ROMANIA S.R.L.
Strada Înfrățirii, F.N.
315100 Chisineu-Cris (Arad) - România
Tel. +40 257 307030
Fax +40 257 307040
info@maschio.ro

MASCHIO GASPARDO NORTH AMERICA, Inc.
112 3rd Avenue East
Dewitt IA 52742 - USA
Tel. +1 563 6596400
Fax +1 563 6596405
info@maschio.us

MASCHIO-GASPARDO IBERICA S.L.
MASCHIO DEUTSCHLAND GMBH
MASCHIO-GASPARDO UCRAINA
GASPARDO-MASCHIO TURCHIA
MASCHIO-GASPARDO CINA
MASCHIO-GASPARDO INDIA